

## **Advantages of Caged Ball™ Technology**

High speed performance  
Low noise design, Long service life,  
Long-term maintenance-free operation  
Reduction in rolling resistance variation

# **SHS**

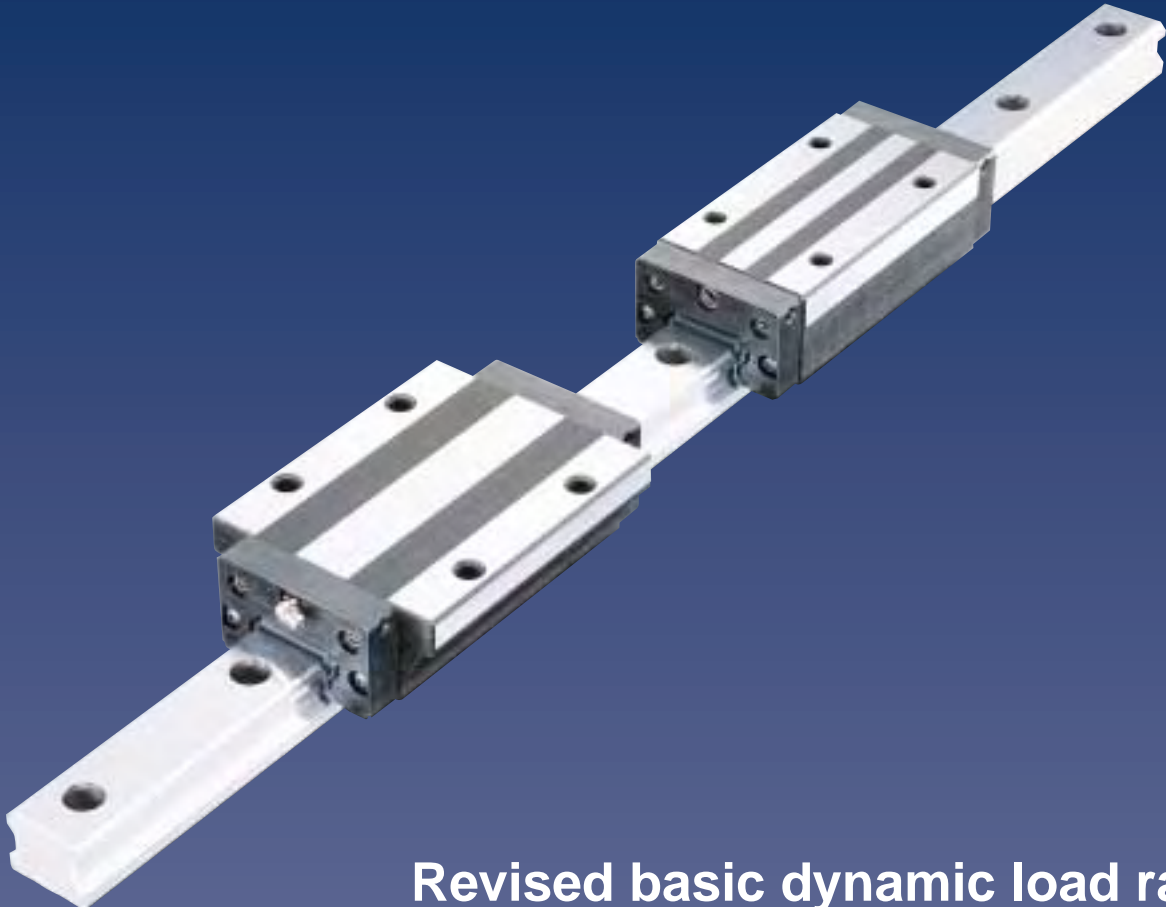

**Revised basic dynamic load ratings**

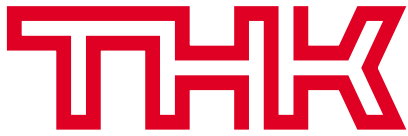

Type SHS conforms to that of type HSR, which THK developed as a pioneer of linear motion systems. This design has virtually become the global standard.

### Four way equal load rating LM Guide® with Caged Ball™ Technology

# SHS

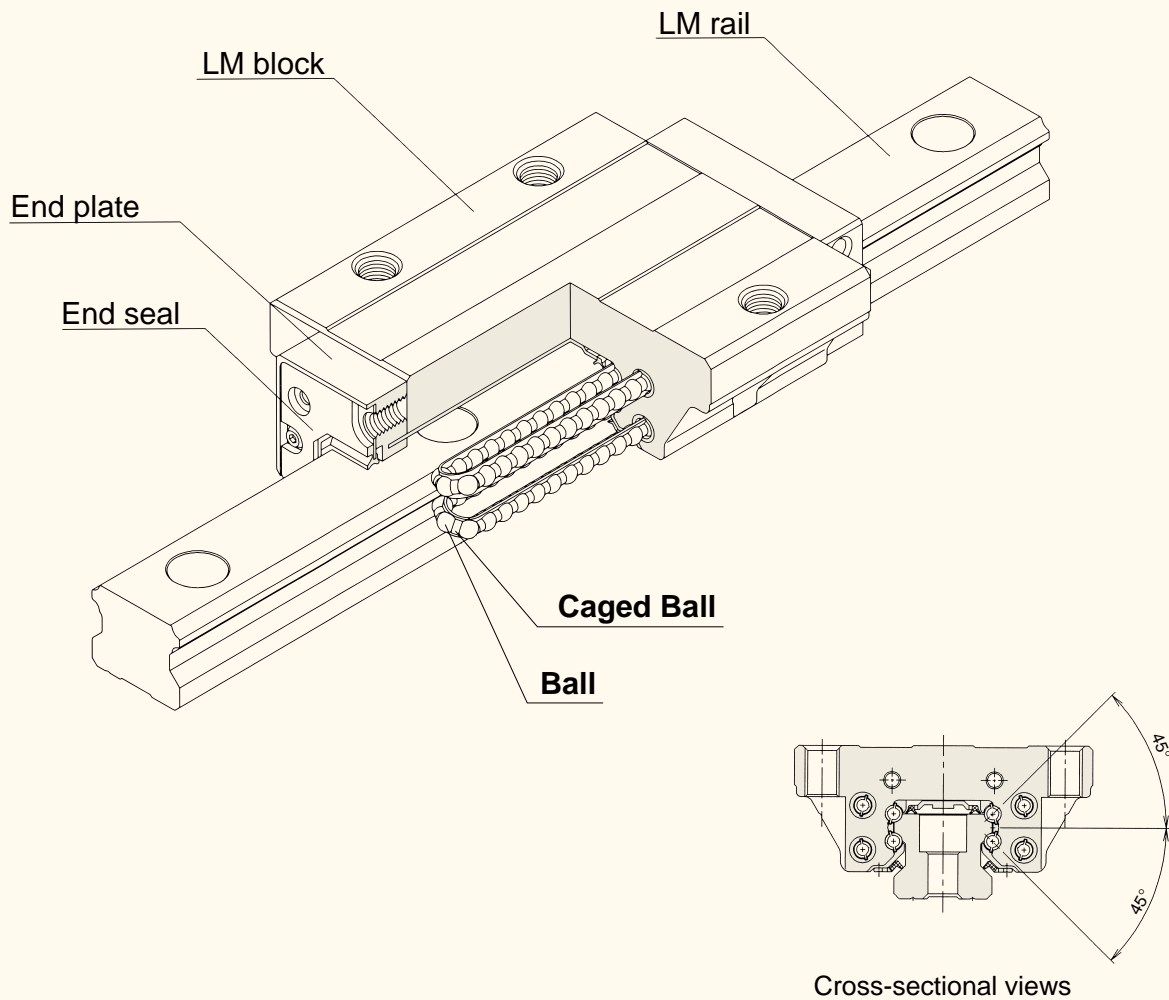
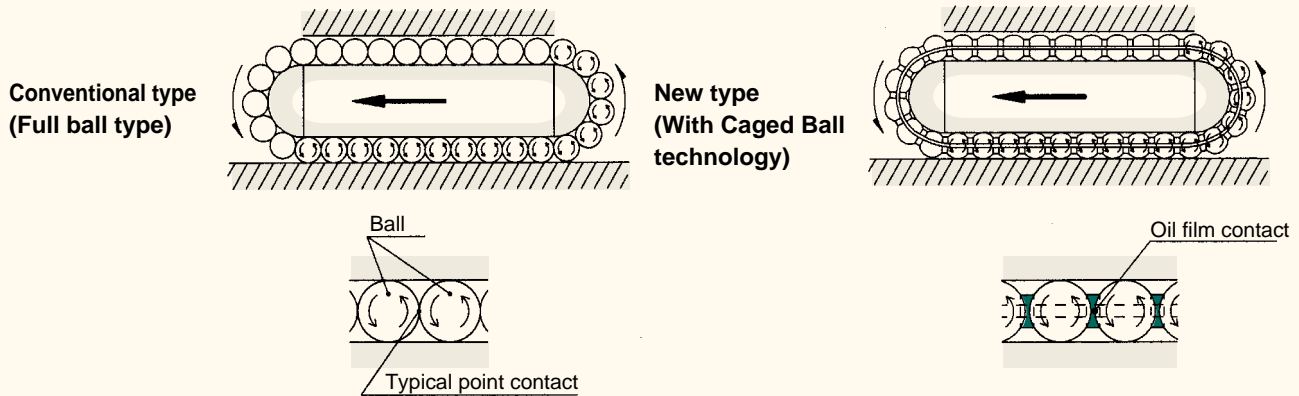

Figure 1 Structure of type SHS

**The four way equal load rating LM Guide® (linear motion guide) with Caged Ball™ Technology for low noise, long-term maintenance-free, and higher speed operation**

## Friction of the balls

### ■Linear motion guide



### ■Rotary ball bearing

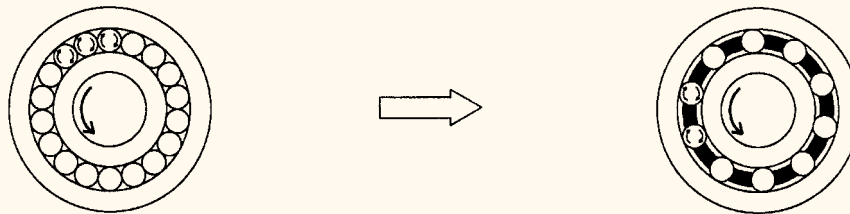

#### In the first stage of development (Full ball type)

- Adjacent balls contact each other at a point. As a result, the contact stress is large and the oil film brakes down due to friction.
- The life becomes shorter.

#### Present bearing (With ball cage)

- The life is extended due to the absence of friction.
- Heat generation during high-speed rotation is limited due to the absence of the friction between adjacent balls.
- The balls do not contact each other. Noise does not arise from the metal to metal contact.
- Balls move smoothly because they are positioned evenly.
- The lubricating oil retained between the balls provides excellent lubrication and long life.

At the time rotary ball bearings were invented, they had no ball cages. This resulted in loud noise during operation, a short running life, and did not have the ability to be run at high speeds.

20 years later, rotary ball bearings with ball cages were developed. This type was quieter in operation and capable of high rotational speeds. Although containing less balls, it provided excellent running life and contributed to the major success of rotary bearings.

The history of the needle bearing revealed how quality improved through the use of ball cages. Balls, at their point of contact, slip against each other in opposite directions and at twice the speed of each of their rotation. This resulted in severe wear, loud noise, and a short running life. The massive pressure from the metal to metal contact and slip between the balls also caused the oil film to break down.

Alternatively, balls and ball cage contact each other over a large surface area and at half the relative velocity. This prevents the break down of oil and provides for quieter operation, higher rotational speeds, longer running life and extended maintenance.

**At THK, we utilized our many years of experience along with innovative manufacturing techniques to develop the new Caged Ball™ Technology, and we have built this technology into the new generation of smooth-running LM guides. The main features of the new LM guides are as follows.**

### **Low Noise and Favorable Sound Quality**

Since the balls move in an orderly manner due to the presence of the ball cages, the metallic sound produced by collision between adjacent balls is eliminated, thereby resulting in low noise levels and favorable sound quality.

### **Long service life, long-term maintenance-free operation**

Adjacent balls, separated by the ball cage, do not rub against each other and produce friction. As a result, the balls are not subject to wear and tear. In addition, the grease retention has been enhanced, providing long service life, long-term maintenance-free operation.

### **Excellent high-speed performance**

Caged Ball LM Guides exhibit excellent high-speed performance through reduced heat generation due to lower bearing stress and half the ball contact velocity. The life of the balls is also prolonged due to the elimination of the friction and wear between adjacent balls.

### **Super smooth movement**

Smooth movement with less variation of torque can be obtained as the balls are lined uniformly and circulated.

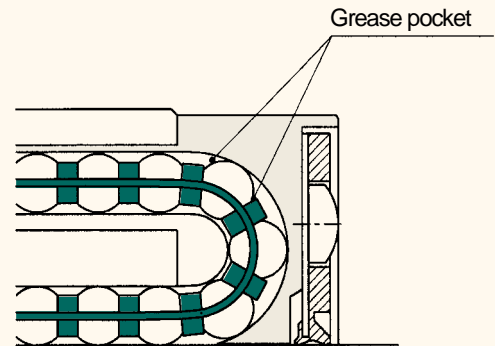
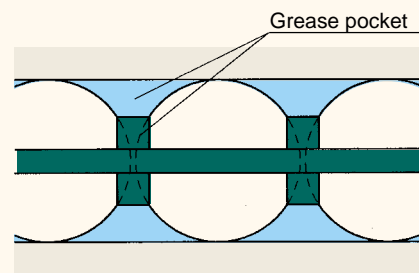

Figure 2 Ball circulating section



The grease circulates with the aid of a ball cage.

Figure 3 Grease pocket

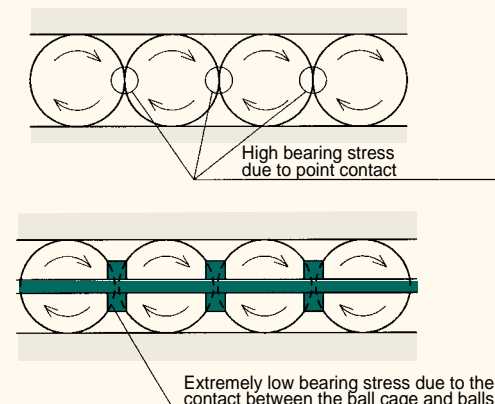

Figure 4 Friction

Since the effect of the ball cages eliminates friction between adjacent balls while also enhancing the retention of grease, the basic dynamic load ratings have been revised.

Model number	Basic load rating C kN
SHS15R	14.2
SHS25R	31.7
SHS30R	44.8
SHS35R	62.3
SHS45R	82.8
SHS55R	128

Model number	Basic load rating C kN
HSR15R(M)	8.33
HSR25R(M)	19.9
HSR30R(M)	28
HSR35R(M)	37.3
HSR45R(M)	60
HSR55R(M)	88.5

Comparison of basic dynamic load ratings between the SNR type of LM Guide with ball cages and the NR type of packed ball LM Guide.

## ■ Noise level data

Type SHS has ball-circulating sections made of resin molded in the block. This structure eliminates metallic noise caused by balls contacting the block. The use of a ball cage has also eliminated metallic noise produced by balls hitting each other. Thus, type SHS operates quietly even at high speed. In addition, a ball cage is effective in preventing balls from rubbing against each other, resulting in low heat generation and a super high speed performance.

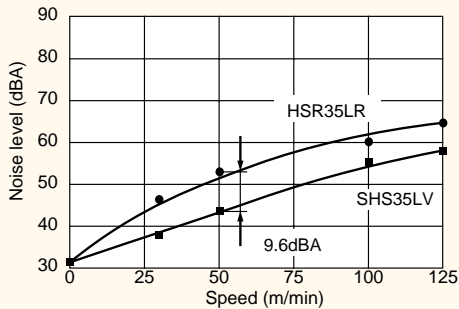

Comparison of the noise levels of SHS35LV and HSR35LR

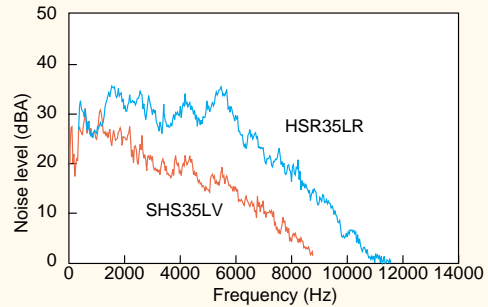

Comparison of the noise levels of SHS35LV and HSR35LR (Speed : 50m/min)

## ■ Result of high speed durability test

Test sample : SHS65LVSS  
 Speed : 200m/min  
 Stroke : 2500mm  
 Initial sealed amount of grease : 25~30cm<sup>3</sup>  
 Acting load : 34.5kN  
 Acceleration : 1.5G

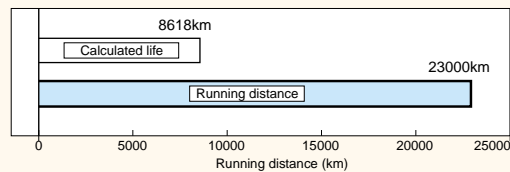

## ■ Less variation of rolling resistance

Type SHS is equipped with ball cage that uniformly arranges the balls. This enables the balls to move in a straight line without meandering when they enter the block. The balls can move smoothly regardless of the mounting position, decreasing variation of rolling resistance and enabling a high degree of accuracy to be achieved.

### Results of measurement of variation in rolling resistance (HSR25LR)

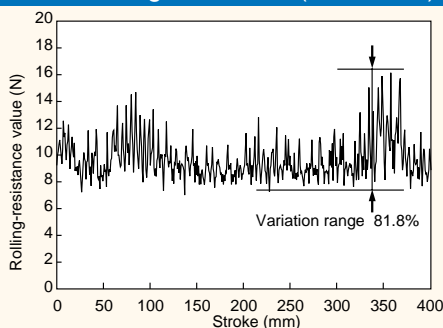

Results of measurement of the rolling resistance variation of HSR25LR (Feeding speed : 1mm/sec)

### Results of measurement of variation in rolling resistance (SHS25LV)

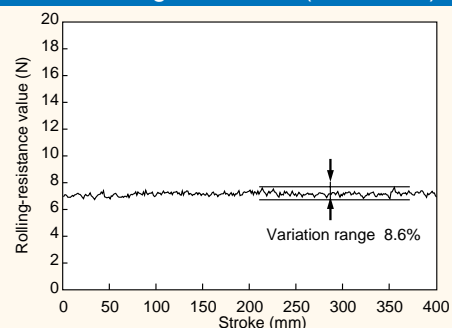

Results of measurement of the rolling resistance variation of SHS25LV (Feeding speed : 1mm/sec)

# **SHS** features

## **Four way equal load rating**

This LM system can be used for different applications in any position because each row of balls is arranged at a 45° contact angle, so that the same load rating is applied to the LM block in four directions (radial, reverse radial, and lateral directions).

## **Automatic adjustment capability**

Because of the automatic adjustment capability of THK's unique circular arc groove design (face to face/DF), mounting misalignment can be eliminated, even when a preload is applied. As a result, precise, smooth linear movement is achieved.

## **Global standard dimensions**

The design of type SHS conforms to that of type HSR, which THK developed as a pioneer of linear motion systems. This design has virtually become the global standard.

## **Low center of gravity and high rigidity**

The rail section has a compact design, resulting in a low center of gravity and high rigidity.

## Types and features

### For heavy loads

SHS-C

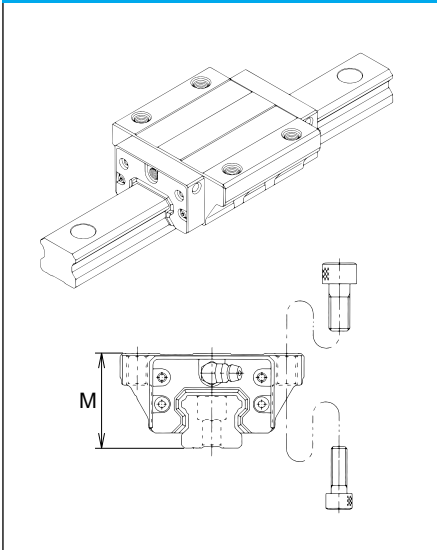

The block of type SHS-C has flanges which are tapped from the top and counterbored from below. This allows for universal installation, by either bolting directly to the block from above, or bolting through the holes from below into the machine.

SHS-V

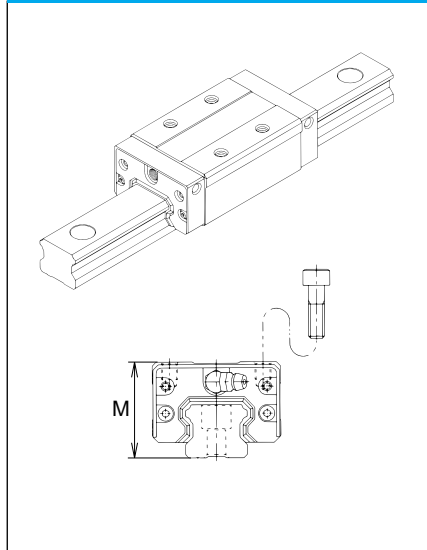

In type SHS-V, the block is narrow, and as tapped holes are machined on the mounting surface, this type is suitable for the build-up system. It can also be used on a table of limited width.

SHS-R

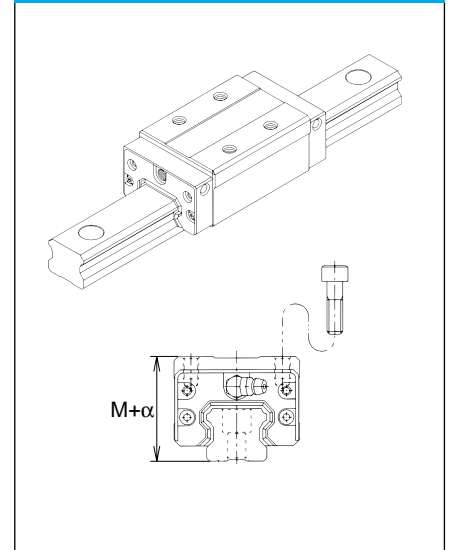

In type SHS-R, the block is narrow, and as tapped holes are machined on the mounting surface, this type is suitable for the build-up system. The height of this type is the same as that of type HSR-R.

### For ultra-heavy loads

SHS-LC

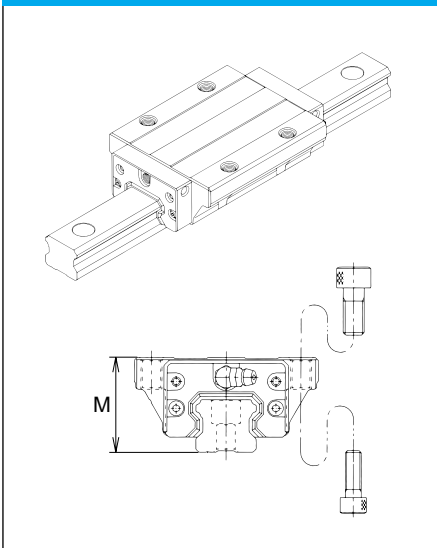

Type SHS-LC has the same cross section as type SHS-C. With the increased number of balls, it is for handling ultra-heavy loads.

SHS-LV

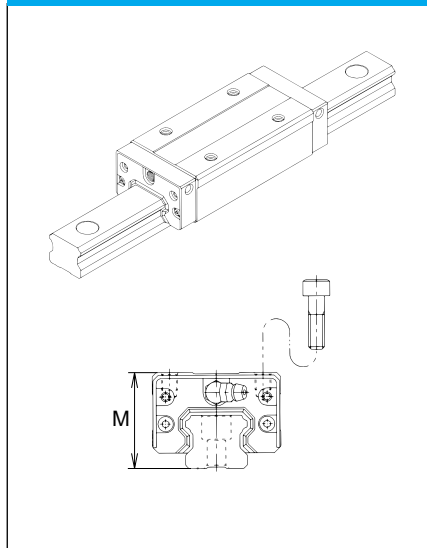

Type SHS-LV has the same cross section as type SHS-V. With the increased number of balls, it is for handling ultra-heavy loads.

SHS-LR

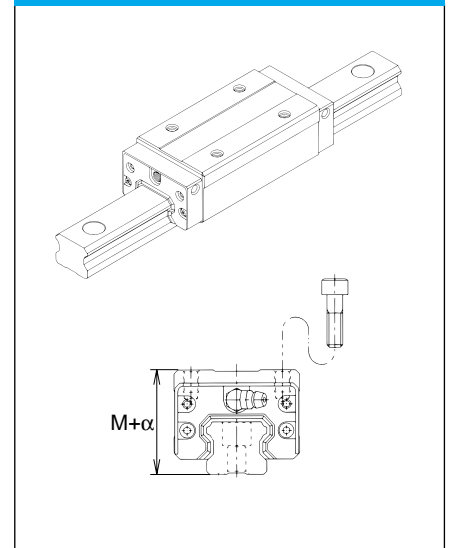

Type SHS-LR has the same cross section as type SHS-R. With the increased number of balls, it is for handling ultra-heavy loads.

## Load ratings and life

Type SHS can support loads in the radial, reverse radial and lateral directions.

The basic load ratings listed in the dimension tables show the load ratings in the radial direction.

### Life calculation

The following equation gives the life of type SHS.

$$L = \left( \frac{f_t \cdot f_c}{f_w} \cdot \frac{C}{P_c} \right)^3 \cdot 50$$

**L** : Rated life (km)

(Total distance of travel reached without flaking by 90% of a group of the same linear motion system that are operated independently under the same conditions)

**C** : Basic dynamic load rating (N)

(The basic dynamic load rating (C) refers to the load that does not vary in direction or magnitude such that the rated service life L is equal to 50 Km when a group of identical LM Guides are individually operated under the same conditions.)

**P<sub>c</sub>** : Design load (N)

**f<sub>t</sub>** : Temperature factor  
(See General Catalog)

**f<sub>c</sub>** : Contact factor  
(See General Catalog)

**f<sub>w</sub>** : Load factor  
(See General Catalog)

Given rated life(L) calculated by the above equation and assuming that the length of stroke and the reciprocating rate are constant, the life in terms of time can be calculated by using the following equation.

$$L_h = \frac{L \times 10^3}{2 \times l_s \times n_1 \times 60}$$

**L<sub>h</sub>** : Life in terms of time (hr)

**l<sub>s</sub>** : Stroke length (m)

**n<sub>1</sub>** : Number of reciprocating motions per minute  
(min<sup>-1</sup>)

## Load ratings and permissible moment in various directions

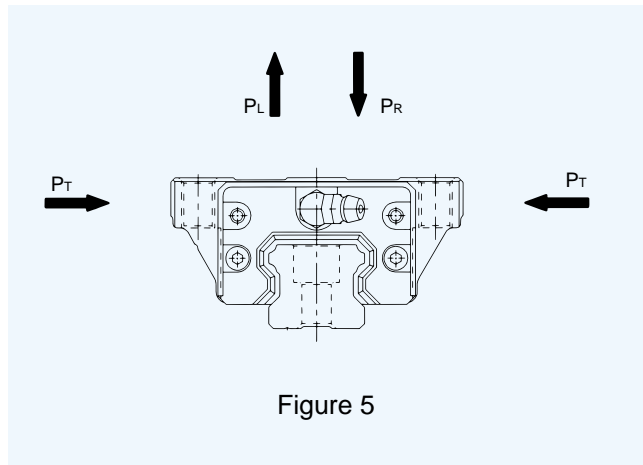

Figure 5

### Load ratings

Type SHS can support loads in the radial, reverse radial, and lateral directions. The basic load ratings (radial, reverse radial, and lateral directions) are equal, and they are listed in the dimension tables.

### Equivalent load

When the LM block of type SHS is subjected to load of each direction simultaneously, the equivalent load can be calculated by using the following equation.

$$P_E = P_R (P_L) + P_T$$

**P<sub>E</sub>** : Equivalent load (N)

- Radial
- Reverse radial
- Lateral

**P<sub>R</sub>** : Radial load(N)

**P<sub>L</sub>** : Reverse radial load(N)

**P<sub>T</sub>** : Lateral load(N)



## Permissible moment load

Type SHS can take moment load in all three directions with only one LM block. Table 1 lists the values for the permissible moment load with one LM block and two blocks in tandem in three directions,  $M_A$ ,  $M_B$  and  $M_C$  ( except  $M_C$  for two blocks in tandem ).

Table 1 Static permissible moment of type SHS

Unit : kN-m

Model No.	Direction	$M_A$		$M_B$		$M_C$
		One block	Two blocks in tandem	One block	Two blocks in tandem	One block
SHS 15		0.15	0.79	0.15	0.79	0.17
SHS 15L		0.26	1.01	0.26	1.01	0.23
SHS 20		0.31	1.53	0.31	1.53	0.39
SHS 20L		0.52	2.45	0.52	2.45	0.51
SHS 25		0.49	2.42	0.49	2.42	0.61
SHS 25L		0.74	3.50	0.74	3.50	0.75
SHS 30		0.68	3.58	0.68	3.58	0.93
SHS 30L		1.19	5.80	1.19	5.80	1.24
SHS 35		1.21	5.93	1.21	5.93	1.65
SHS 35L		2.04	9.57	2.04	9.57	2.17
SHS 45		1.79	8.90	1.79	8.9	2.89
SHS 45L		3.02	14.3	3.02	14.3	3.79
SHS 55		3.46	17.0	3.46	17.0	5.27
SHS 55L		5.83	27.4	5.83	27.4	6.92
SHS 65		7.58	35.2	7.58	35.2	10.1
SHS 65L		12.2	54.8	12.2	54.8	12.9

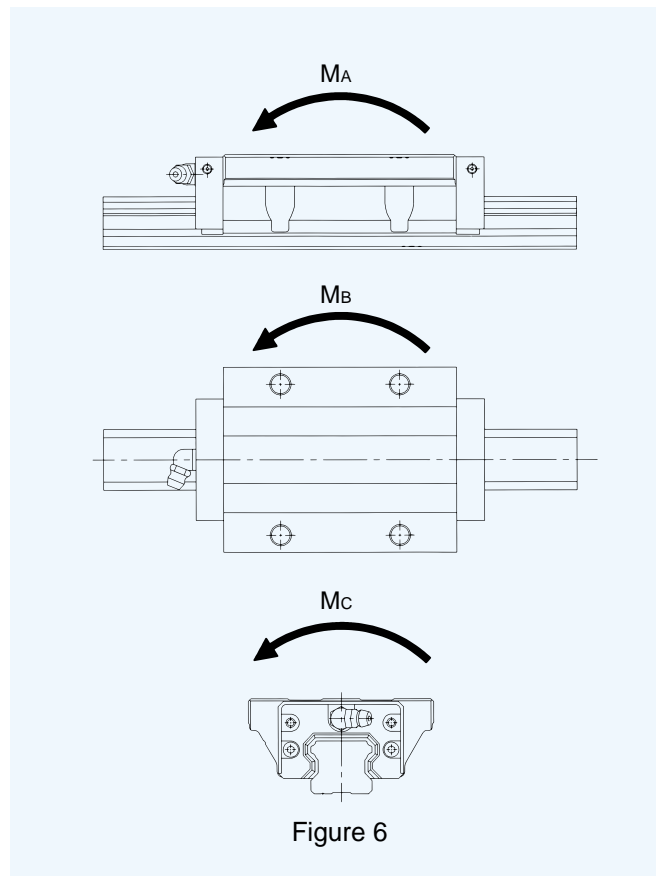

## Accuracy standard

Table 2 shows the accuracy of type SHS. Accuracy is defined by the running parallelism and tolerances of height and width. When two or more LM blocks are installed on one rail or when two or more rails are specified as matched sets, accuracy is defined by the differences in height and width of the individual LM blocks.

The accuracy of type SHS is classified into normal, high, precision, super-precision and ultra-precision grades as shown in Table 2.

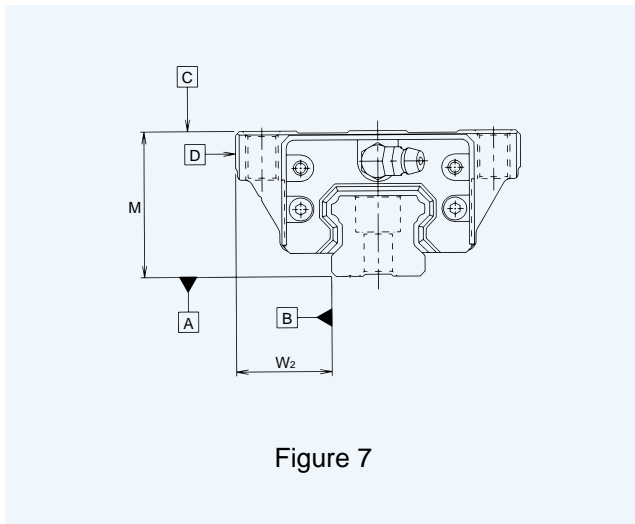

Figure 7

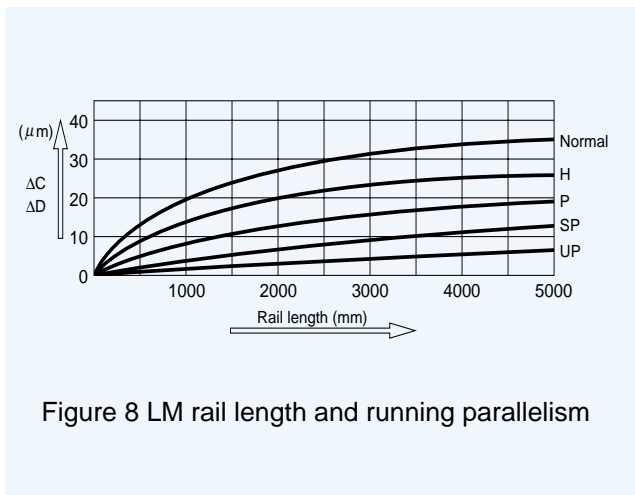

Figure 8 LM rail length and running parallelism

Table 2 Accuracy standard

Unit: mm

Model number	Accuracy grade	Normal	High	Precision	Super-precision	Ultra-precision
SHS 15 20	Item	No symbol	H	P	SP	UP
	Tolerance of height M	±0.1	±0.03	$\begin{matrix} 0 \\ -0.03 \end{matrix}$	$\begin{matrix} 0 \\ -0.015 \end{matrix}$	$\begin{matrix} 0 \\ -0.008 \end{matrix}$
	Difference in height M	0.02	0.01	0.006	0.004	0.003
	Tolerance of width W <sub>2</sub>	±0.1	±0.03	$\begin{matrix} 0 \\ -0.03 \end{matrix}$	$\begin{matrix} 0 \\ -0.015 \end{matrix}$	$\begin{matrix} 0 \\ -0.008 \end{matrix}$
	Difference of width W <sub>2</sub>	0.02	0.01	0.006	0.004	0.003
	Running parallelism of LM block surface <b>C</b> with respect to surface <b>A</b>	ΔC (Refer to Figure 8)				
	Running parallelism of LM block surface <b>D</b> with respect to surface <b>B</b>	ΔD (Refer to Figure 8)				
SHS 25 30 35	Item	No symbol	H	P	SP	UP
	Tolerance of height M	±0.1	±0.04	$\begin{matrix} 0 \\ -0.04 \end{matrix}$	$\begin{matrix} 0 \\ -0.02 \end{matrix}$	$\begin{matrix} 0 \\ -0.01 \end{matrix}$
	Difference in height M	0.02	0.015	0.007	0.005	0.003
	Tolerance of width W <sub>2</sub>	±0.1	±0.04	$\begin{matrix} 0 \\ -0.04 \end{matrix}$	$\begin{matrix} 0 \\ -0.02 \end{matrix}$	$\begin{matrix} 0 \\ -0.01 \end{matrix}$
	Difference of width W <sub>2</sub>	0.03	0.015	0.007	0.005	0.003
	Running parallelism of LM block surface <b>C</b> with respect to surface <b>A</b>	ΔC (Refer to Figure 8)				
	Running parallelism of LM block surface <b>D</b> with respect to surface <b>B</b>	ΔD (Refer to Figure 8)				
SHS 45 55	Item	No symbol	H	P	SP	UP
	Tolerance of height M	±0.1	±0.05	$\begin{matrix} 0 \\ -0.05 \end{matrix}$	$\begin{matrix} 0 \\ -0.03 \end{matrix}$	$\begin{matrix} 0 \\ -0.02 \end{matrix}$
	Difference in height M	0.03	0.015	0.007	0.005	0.003
	Tolerance of width W <sub>2</sub>	±0.1	±0.05	$\begin{matrix} 0 \\ -0.05 \end{matrix}$	$\begin{matrix} 0 \\ -0.03 \end{matrix}$	$\begin{matrix} 0 \\ -0.02 \end{matrix}$
	Difference of width W <sub>2</sub>	0.03	0.02	0.01	0.007	0.005
	Running parallelism of LM block surface <b>C</b> with respect to surface <b>A</b>	ΔC (Refer to Figure 8)				
	Running parallelism of LM block surface <b>D</b> with respect to surface <b>B</b>	ΔD (Refer to Figure 8)				
SHS 65	Item	No symbol	H	P	SP	UP
	Tolerance of height M	±0.1	±0.07	$\begin{matrix} 0 \\ -0.07 \end{matrix}$	$\begin{matrix} 0 \\ -0.05 \end{matrix}$	$\begin{matrix} 0 \\ -0.03 \end{matrix}$
	Difference in height M	0.03	0.02	0.01	0.007	0.005
	Tolerance of width W <sub>2</sub>	±0.1	±0.07	$\begin{matrix} 0 \\ -0.07 \end{matrix}$	$\begin{matrix} 0 \\ -0.05 \end{matrix}$	$\begin{matrix} 0 \\ -0.03 \end{matrix}$
	Difference of width W <sub>2</sub>	0.03	0.025	0.015	0.010	0.007
	Running parallelism of LM block surface <b>C</b> with respect to surface <b>A</b>	ΔC (Refer to Figure 8)				
	Running parallelism of LM block surface <b>D</b> with respect to surface <b>B</b>	ΔD (Refer to Figure 8)				

## Radial clearance

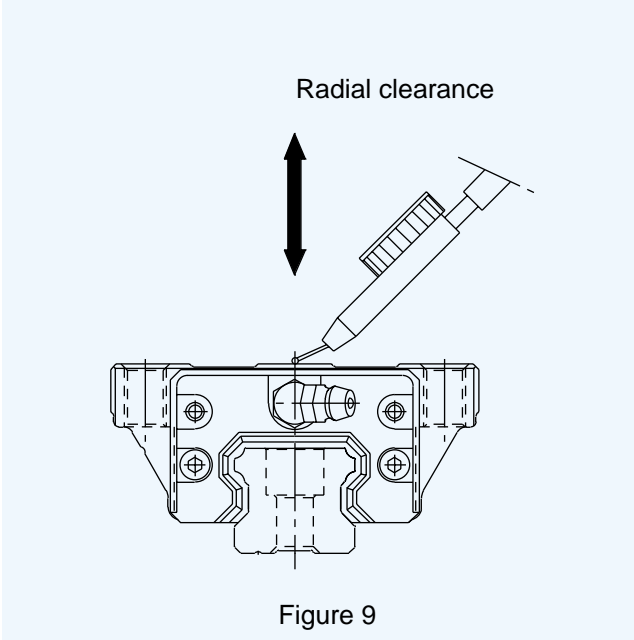

Table 3 lists the radial clearance of type SHS.

Table 3 Radial clearance of type SHS

Unit :  $\mu\text{m}$

Model number	Symbol	Normal	Light preload	Medium preload
	No symbol	C1	C0	
SHS 15	-	5 ~ 0	-12 ~ -5	—
SHS 20	-	6 ~ 0	-12 ~ -6	-18 ~ -12
SHS 25	-	8 ~ 0	-14 ~ -8	-20 ~ -14
SHS 30	-	9 ~ 0	-17 ~ -9	-27 ~ -17
SHS 35	-	11 ~ 0	-19 ~ -11	-29 ~ -19
SHS 45	-	12 ~ 0	-22 ~ -12	-32 ~ -22
SHS 55	-	15 ~ 0	-28 ~ -16	-38 ~ -28
SHS 65	-	18 ~ 0	-34 ~ -22	-45 ~ -34

Note : No symbol is necessary for normal clearance. Add the corresponding symbols to the model number if C0 or C1 clearance is required. See the descriptions for the model number coding.

## Model number coding

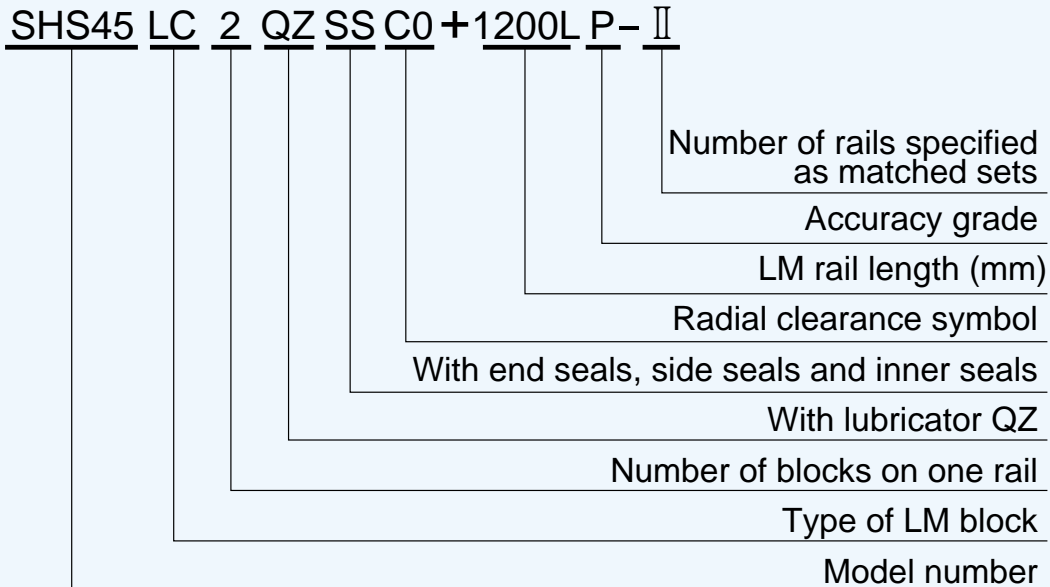

Note: This model number is for one rail unit on a one set basis. When two rails are to be specified as matched sets, at least two rail and block assemblies are necessary.

Note: Type SHS is equipped with SS (End seals + side seals + inner seals) as standard.

## Options

Linear Motion System is subject to the entry of foreign matter, dust and moisture, which lead to abnormal wear, damage of the rolling groove and balls, and breakage of the circulation section. Such occurrences may shorten the service life of the system.

Thus, when contamination by foreign matter, dust and so on is likely, it is necessary to take appropriate measures to prevent these occurrences, while meeting your service conditions. THK provides a wide variety of accessories designed to meet various service conditions.

### 1. Seals

#### End seals

End seals will be attached to both end faces of LM block. This end seal prevents foreign matter and moisture adhering to the LM rail top and side surfaces from entering the LM block. The end seals are available as standard parts to prevent lubricant leakage in the LM block as well.

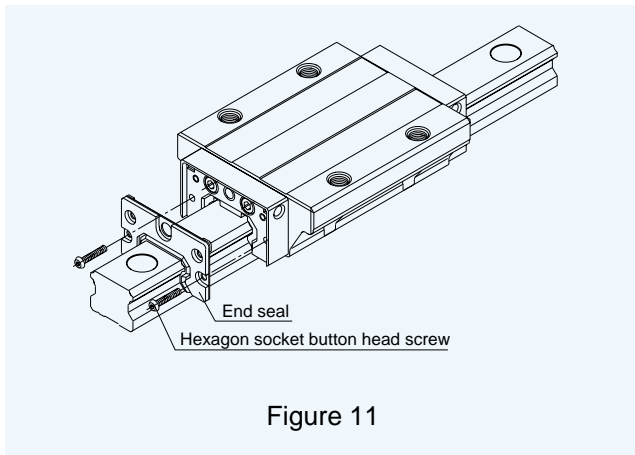

Figure 11

#### Side seals

This side seal prevents foreign matter and moisture from entering from the bottom and sides of the LM block. It also prevents the lubricant from leaking from the bottom of the block.

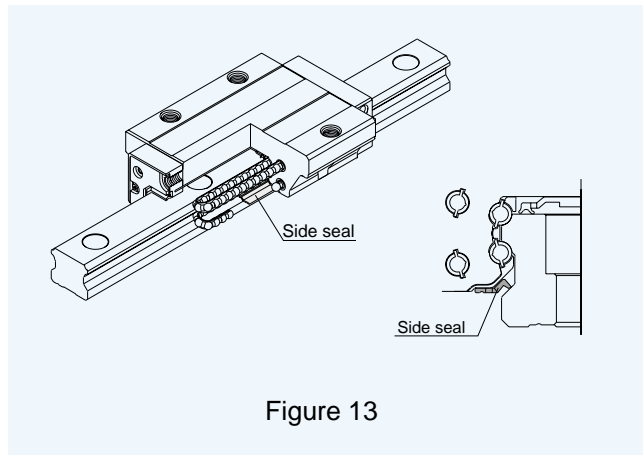

Figure 13

#### Double seals

This is an option for even higher airtightness. Foreign matter entering the first end seal is trapped by the second end seal, and is therefore unable to invade the LM block.

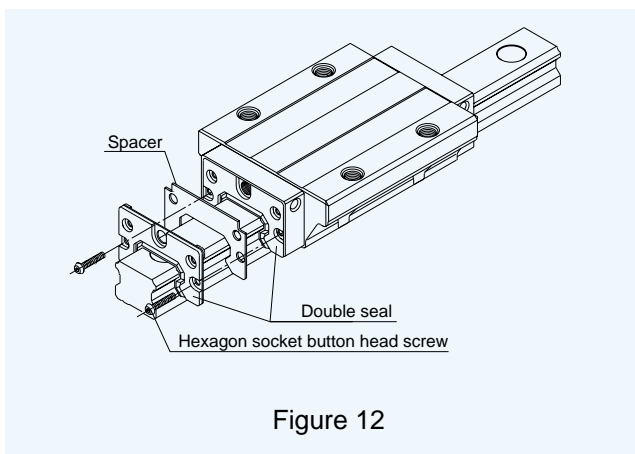

Figure 12

#### Inner seals

Tiny particles of foreign matter and dust may enter an end seal. The inner seal prevents them from reaching the ball rolling surfaces even if they enter the LM block. The inner seal can hold lubricant on the ball rolling surfaces as well.

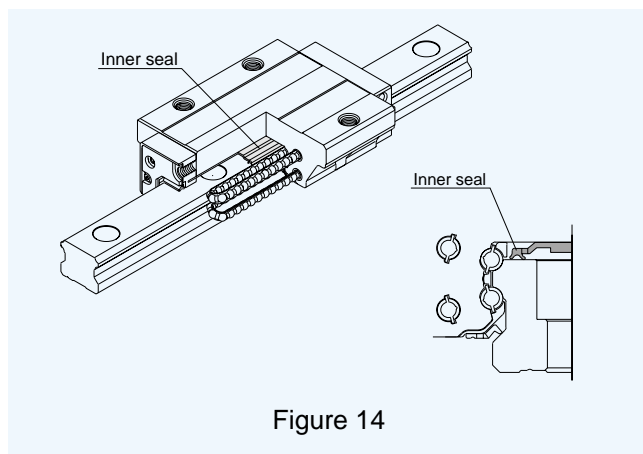

Figure 14

## LaCS (Laminated contact scrapers)

Unlike a metal scraper, this contact scraper contacts the LM rail over a surface. The surface-to-surface contact protects the rail from microscopic foreign matter far more effectively than conventional metal scrapers can. The contact scraper is thus a highly effective anti-dust accessory.

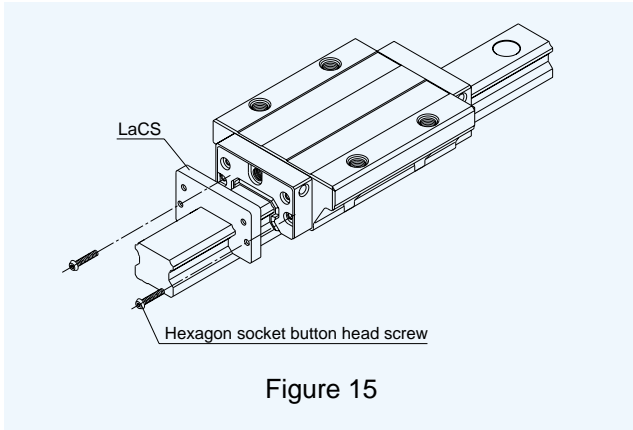

Figure 15

## Metal scrapers (non-contact)

Metal scraper is used to remove relatively large or hard particles of foreign matter adhering to the LM rail, such as chips, spatter, and dust.

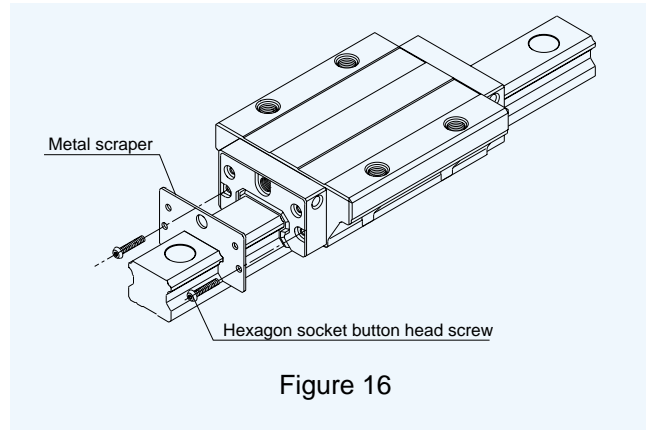

Figure 16

## Symbols for contamination protection system

When contamination protection is required, specify according to code shown. The entire block length may vary depending on the type used. Add the increased dimensions (refer to Table 4) to the corresponding "L" value shown in the dimension tables.

Symbol	Protection system
UU	With end seal (on both ends)
SS	With end seals, side seals and inner seals
ZZ	With end seals, side seals, inner seals and metal scrapers
DD	With double seals, side seals and inner seals
KK	With double seals, side seals, inner seals and metal scrapers
ZZHH	With end seals, side seals, inner seals, metal scrapers and LaCS
KKHH	With double seals, side seals, inner seals, metal scrapers and LaCS

## 2. Plate covers

The extremely thin stainless steel plate (SUS304) covers the LM rail mounting holes to further increase the airtightness of the end seal. This plate cover prevents foreign matter and moisture from entering from above the rail.

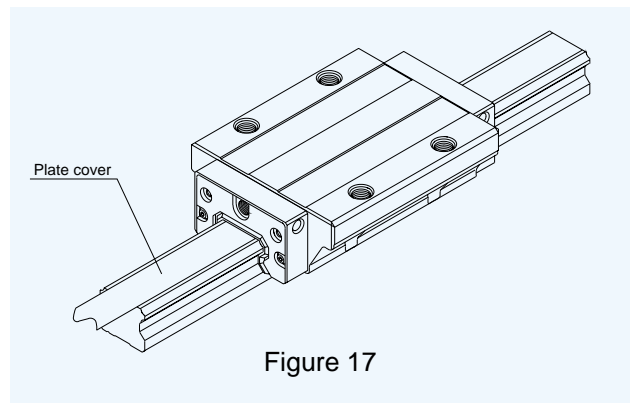

Figure 17

### 3. Bellows

Dimensions of type JSH bellows for LM Guide type SHS are indicated below. Please specify the product according to the model numbers.

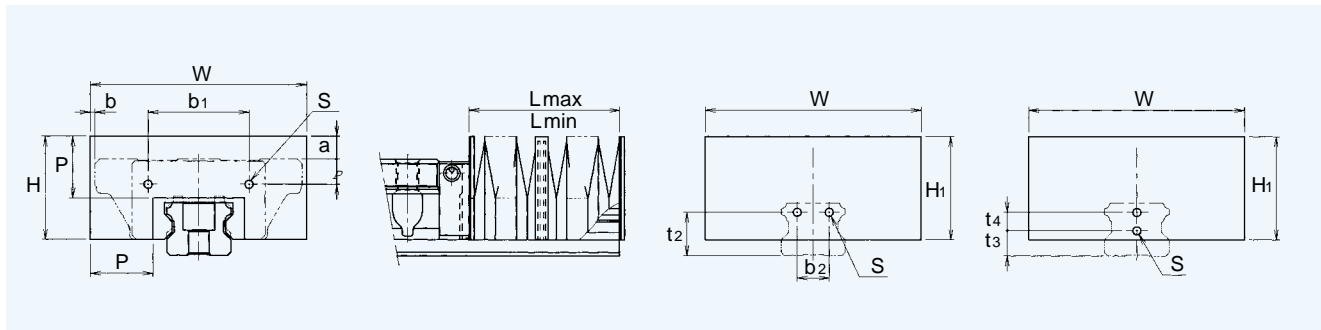

Table 4 Type JSH dimensions

Model number	Main dimensions (mm)												Applicable Model No.
	W	H	H <sub>1</sub>	P	b <sub>1</sub>	t <sub>1</sub>			b <sub>2</sub>	t <sub>2</sub>	t <sub>3</sub>	t <sub>4</sub>	
						C type	V type	R type					
JSH15	53	26	26	15	22.4	4	4	8	—	—	8	—	SHS15
JSH20	60	30	30	17	27.6	7.5	7.5	—	—	—	8	6	SHS20
JSH25	75	36	36	20	38	9.1	9.1	13.1	—	—	9	7	SHS25
JSH30	80	38	38	20	44	11	11	14	—	—	11	8	SHS30
JSH35	86	40.5	40.5	20	50	11	11	18	20	21.5	—	—	SHS35
JSH45	97	46	46	20	64.6	13.5	13.5	23.5	26	26.5	—	—	SHS45
JSH55	105	48	48	20	68	13	13	23	30	31.5	—	—	SHS55
JSH65	126	63	63	25	80	18	18	—	34	45	—	—	SHS65

Applicable Model No.	Fixing bolt S Upper : Block side Lower : Rail side	Various dimensions (mm)							A ( $\frac{L_{max}}{L_{min}}$ )
		C type	a V type	R type	b				
					C type	V type	R type		
SHS15	M2 × 8 L M4 × 8 L	5	5	1	3	9.5	9.5	5	
SHS20	M2.6 × 8 L M3 × 6 L	5	5	—	— 1.5	8	—	6	
SHS25	M3 × 8 L M3 × 6 L	6	6	2	2.5	13.5	13.5	7	
SHS30	M3 × 10 L M3 × 6 L	3	3	0	— 5	10	10	7	
SHS35	M4 × 10 L M4 × 8 L	0	0	— 7	— 7	8	8	7	
SHS45	M4 × 12 L M4 × 8 L	—5	—5	—15	—11.7	5.5	5.5	7	
SHS55	M5 × 12 L M5 × 10 L	—9	—9	—19	—17.5	2.5	2.5	7	
SHS65	M6 × 14 L M6 × 12 L	—8	—8	—	—22	0	—	9	

#### Model number coding

JSH35 - 60/420

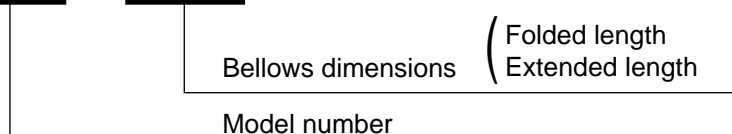

## 4. C cap for LM rail mounting hole

When chips or foreign materials enter the LM rail mounting holes of the LM Guide, they may enter the LM block. Contaminants can be prevented from entering the LM block by covering those LM rail mounting holes with special caps and ensuring that the caps are flush with the top surface of the LM rail.

The special cap type C for LM rail mounting holes is made of a special synthetic resin with a high degree of oilproofing and wear resistance for excellent durability. Special caps for hexagon socket head set screws M4-M16 are kept in stock as standard equipment. When it is necessary to order special caps, specify them using the nominal numbers in the dimension table.

To insert a special cap in a mounting hole, apply a flat metal piece to the cap, as shown in Figure 18, and then gently tap the metal until the cap becomes flush with the top of the LM rail.

Table 5 Main dimensions of C cap

Applicable No	C cap	Screw	Main dimensions (mm)	
			D	H
SHS15	C4	M4	7.8	1.0
SHS20	C5	M5	9.8	2.4
SHS25	C6	M6	11.4	2.7
SHS30	C8	M8	14.4	3.7
SHS35	C8	M8	14.4	3.7
SHS45	C12	M12	20.5	4.7
SHS55	C14	M14	23.5	5.7
SHS65	C16	M16	26.5	5.7

## 5. Lubricator QZ™

THK has developed the lubricator QZ containing a fiber net (occluding element) with high oil content in order to meet the requirement for long-term maintenance-free technology in LM Guide lubrication.

- **Maintenance intervals can be greatly extended.**

Normally in LM systems, a (very) small amount of oil is lost as the machine runs. By mounting the lubricator QZ on the LM block, lost oil is automatically replaced, greatly extending maintenance intervals.

- **Lubricator QZ is environmentally conscious.**

Because lubricator QZ uses a high-density fiber net to supply the appropriate amount of oil to the appropriate positions, there is no excess oil, making it an environmentally conscious design.

- **The best oil for each application can be used.**

Lubricator QZ permits the use of the most suitable oil for LM Guide.

Lubricator QZ is available as a standard option for type SHS. See CATALOG No. 230-E for details.

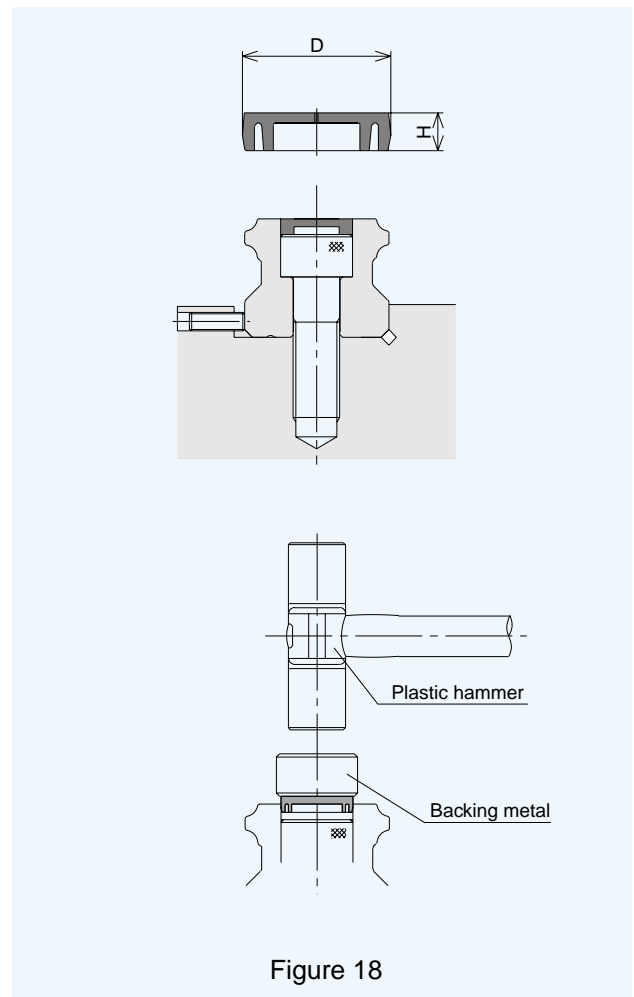

Figure 18

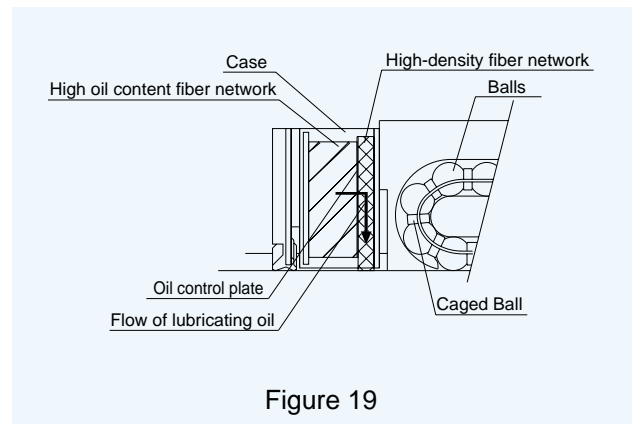

Figure 19



### Shoulder height and bottom corner of installation surfaces

For installation, recommended shoulder height is listed in Table 6. Also, bottom corner of shoulder should have relief or radius less than  $r$  in Table 6.

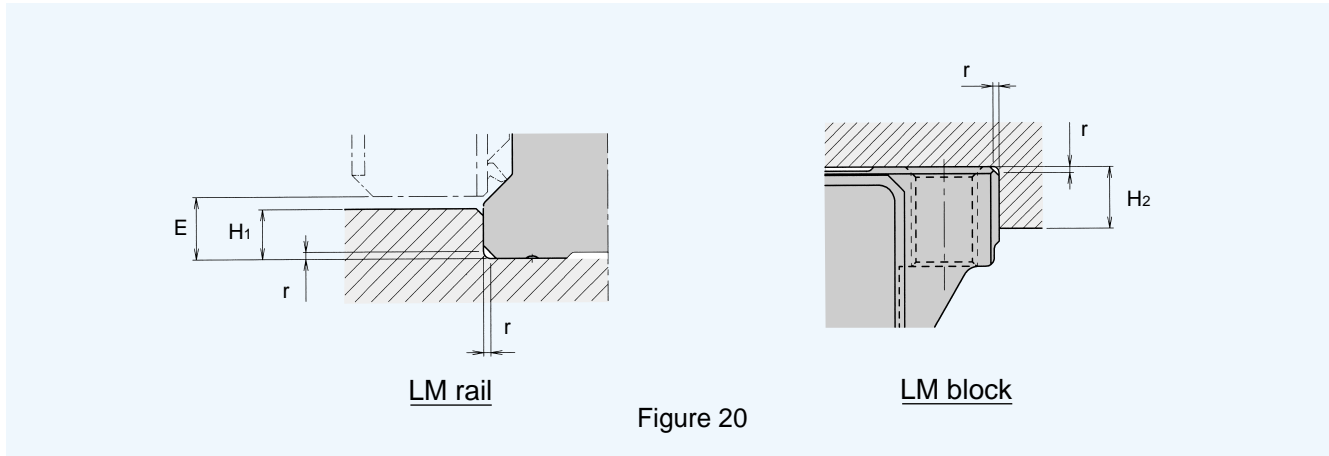

Table 6 Heights and radius of bottom corner

Unit : mm

Model number	Radius of bottom corner $r$ (maximum)	Shoulder height accommodating LM rail $H_1$	Shoulder height accommodating LM block $H_2$	E
SHS 15	0.5	2.5	4	3.0
SHS 20	0.5	3.5	5	4.6
SHS 25	1.0	5.0	5	5.8
SHS 30	1.0	5.0	5	7.0
SHS 35	1.0	6.0	6	7.5
SHS 45	1.0	7.5	8	8.9
SHS 55	1.5	10	10	12.7
SHS 65	1.5	15	10	19

### Seal resistance

Regarding type SHS with "SS" seals (end seals and side seals on both ends), Table 7 shows the values of maximum seal resistance for one LM block.

Table 7 Seal resistance

Unit : N

Model number	Seal resistance
SHS 15	4.5
SHS 20	7.0
SHS 25	10.5
SHS 30	17.0
SHS 35	20.5
SHS 45	30.0
SHS 55	31.5
SHS 65	43.0

Note: · The resistance values show the maximum seal resistance generated by one LM block with sealed grease.



## Standard and maximum lengths of LM rails

Table 8 lists the standard and maximum LM rail lengths of type SHS. If a rail longer than the corresponding maximum length is specified, the rail will be in two or more sections.

If a special length is required, G dimension listed in the table is recommended. If the G dimension is too

long, it makes the rail ends insecure which may adversely affect accuracy.

When two or more rails are to be connected, be sure to inform 工厂 of the overall LM rail length. The rails will be machined simultaneously in order to give precise joints.

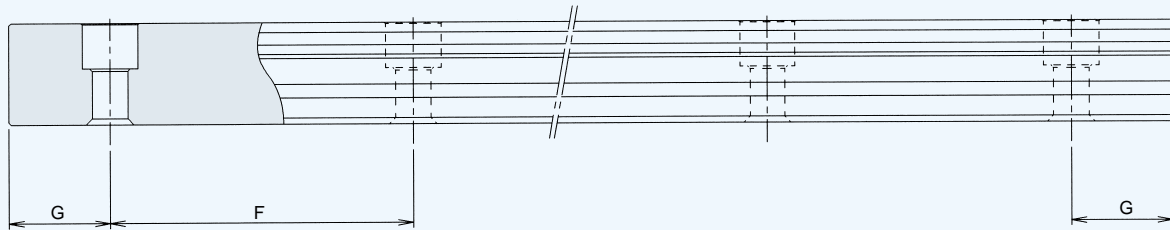

Figure 21

Table 8 Standard and maximum LM rail lengths of type SHS

Unit : mm

Model number	SHS 15	SHS 20	SHS 25	SHS 30	SHS 35	SHS 45	SHS 55	SHS 65
Standard LM rail length (L <sub>0</sub> )	160	220	220	280	280	570	780	1270
	220	280	280	360	360	675	900	1570
	280	340	340	440	440	780	1020	2020
	340	400	400	520	520	885	1140	2620
	400	460	460	600	600	990	1260	
	460	520	520	680	680	1095	1380	
	520	580	580	760	760	1200	1500	
	580	640	640	840	840	1305	1620	
	640	700	700	920	920	1410	1740	
	700	760	760	1000	1000	1515	1860	
	760	820	820	1080	1080	1620	1980	
	820	940	940	1160	1160	1725	2100	
	940	1000	1000	1240	1240	1830	2220	
	1000	1060	1060	1320	1320	1935	2340	
	1060	1120	1120	1400	1400	2040	2460	
	1120	1180	1180	1480	1480	2145	2580	
	1180	1240	1240	1560	1560	2250	2700	
	1240	1360	1300	1640	1640	2355	2820	
	1360	1480	1360	1720	1720	2460	2940	
	1480	1600	1420	1800	1800	2565	3060	
1600	1720	1480	1880	1880	2670			
	1840	1540	1960	1960	2775			
	1960	1600	2040	2040	2880			
	2080	1720	2200	2200	2985			
	2200	1840	2360	2360	3090			
		1960	2520	2520				
		2080	2680	2680				
		2200	2840	2840				
		2320	3000	3000				
		2440						
F	60	60	60	80	80	105	120	150
G	20	20	20	20	20	22.5	30	35
Maximum length	2500	3000	3000	3000	3000	3090	3060	3000

Note:   
 · Maximum length differs depending on accuracy grades. Please contact 工厂 .   
 · If a single-piece LM rail exceeding the corresponding maximum length listed in Table 8 is desired, please contact 工厂 .

# Flange Type

## Type SHS...C (Heavy load type) Type SHS...LC (Ultra heavy load type)

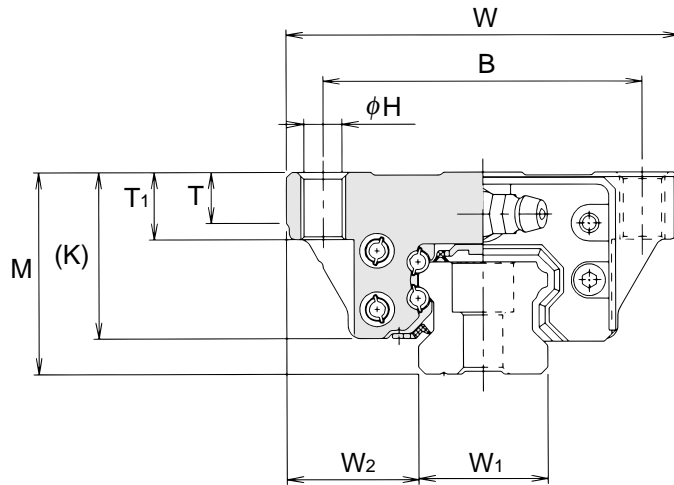

Model number	Outline dimensions			LM block dimensions										
	Height M	Width W	Length L	B	C	S	H	L <sub>1</sub>	T	T <sub>1</sub>	K	N	E	Grease fitting
SHS 15 C	24	47	64.4	38	30	M 5	4.4	48	6	8	21	5.5	5.5	PB1021B
SHS 15 LC			79.4											
SHS 20 C	30	63	79	53	40	M 6	5.4	59	7.2	10	25.4	6.5	12	B-M6F
SHS 20 LC			98											
SHS 25 C	36	70	92	57	45	M 8	6.8	71	9	12	30.2	7.5	12	B-M6F
SHS 25 LC			109											
SHS 30 C	42	90	106	72	52	M10	8.5	80	12	15	35	8	12	B-M6F
SHS 30 LC			131											
SHS 35 C	48	100	122	82	62	M10	8.5	93	12	15	40.5	8	12	B-M6F
SHS 35 LC			152											
SHS 45 C	60	120	140	100	80	M12	10.5	106	14	18	51.1	10.5	16	B-PT1/8
SHS 45 LC			174											
SHS 55 C	70	140	171	116	95	M14	12.5	131	17	21	57.3	11	16	B-PT1/8
SHS 55 LC			213											
SHS 65 C	90	170	221	142	110	M16	14.5	175	20	24	71	19	16	B-PT1/8
SHS 65 LC			272											

Note: ·See page 8 for static permissible moment  $M_A$ ,  $M_B$ ,  $M_C$ .  
·See page 10 for the model number coding.  
·See page 16 for the standard LM rail lengths.

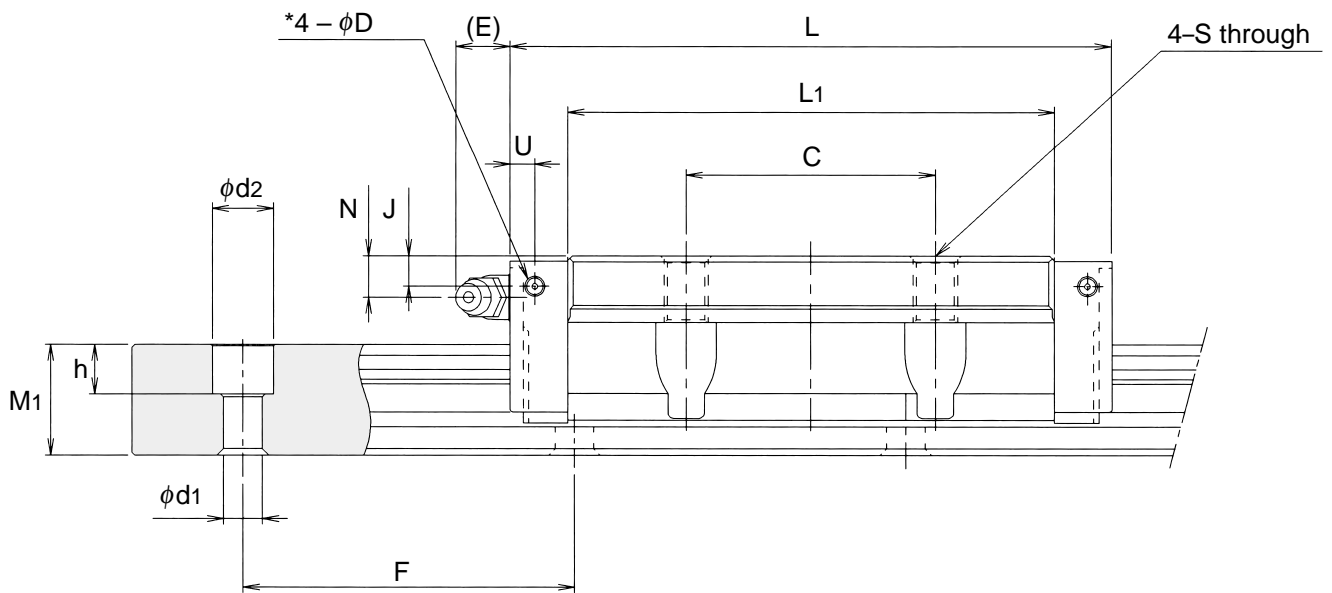

Unit : mm

Hole for side grease fitting*			LM rail dimensions					Basic load rating		Mass	
U	J	D	Width $W_1 \begin{smallmatrix} 0 \\ -0.05 \end{smallmatrix}$	$W_2$	Height $M_1$	Pitch $F$	$d_1 \times d_2 \times h$	C kN	$C_0$ kN	LM block kg	LM rail kg/m
4.2	4	3	15	16	13	60	4.5×7.5×5.3	14.2	24.2	0.23	1.3
								17.2	31.9	0.29	
5.7	5.3	3	20	21.5	16.5	60	6×9.5×8.5	22.3	38.4	0.46	2.3
								28.1	50.3	0.61	
4.5	5.5	3	23	23.5	20	60	7×11×9	31.7	52.4	0.72	3.2
								36.8	64.7	0.89	
7.5	6	5.2	28	31	23	80	9×14×12	44.8	66.6	1.34	4.5
								54.2	88.8	1.66	
8	5.5	5.2	34	33	26	80	9×14×12	62.3	96.6	1.9	6.2
								72.9	127	2.54	
9	8	5.2	45	37.5	32	105	14×20×17	82.8	126	3.24	10.4
								100	166	4.19	
10	8	5.2	53	43.5	38	120	16×23×20	128	197	5.35	14.5
								161	259	6.97	
13	12	5.2	63	53.5	53	150	18×26×22	205	320	10.7	23.7
								253	408	13.7	

\* Holes on the sides of the LM block for lubrication nipples are not made all the way through to prevent foreign materials from entering. Please contact  when using lubrication nipples.

# Thin and Compact Type

## Type SHS...V (Heavy load type)

## Type SHS...LV (Ultra heavy load type)

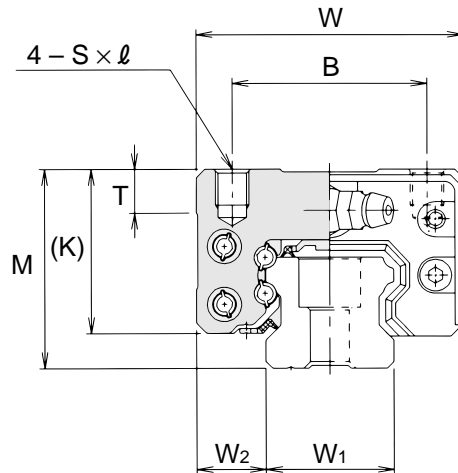

Model number	Outline dimensions			LM block dimensions								
	Height M	Width W	Length L	B	C	$S \times l$	$L_1$	T	K	N	E	Grease fitting
SHS 15 V	24	34	64.4	26	26	M4×4	48	6	21	5.5	5.5	PB1021B
SHS 15 LV			79.4									
SHS 20 V	30	44	79	32	36	M5×5	59	8	25.4	6.5	12	B-M6F
SHS 20 LV			98									
SHS 25 V	36	48	92	35	35	M6×6.5	71	8	30.2	7.5	12	B-M6F
SHS 25 LV			109									
SHS 30 V	42	60	106	40	40	M8×8	80	8.5	35	8	12	B-M6F
SHS 30 LV			131									
SHS 35 V	48	70	122	50	50	M8×10	93	15	40.5	8	12	B-M6F
SHS 35 LV			152									
SHS 45 V	60	86	140	60	60	M10×15	106	15	51.1	10.5	16	B-PT1/8
SHS 45 LV			174									
SHS 55 V	70	100	171	75	75	M12×15	131	20	57.3	11	16	B-PT1/8
SHS 55 LV			213									
SHS 65 V	90	126	221	76	70	M16×20	175	20	71	19	16	B-PT1/8
SHS 65 LV			272									

Note: ·See page 8 for static permissible moment  $M_A$ ,  $M_B$ ,  $M_C$ .  
 ·See page 10 for the model number coding.  
 ·See page 16 for the standard LM rail lengths.

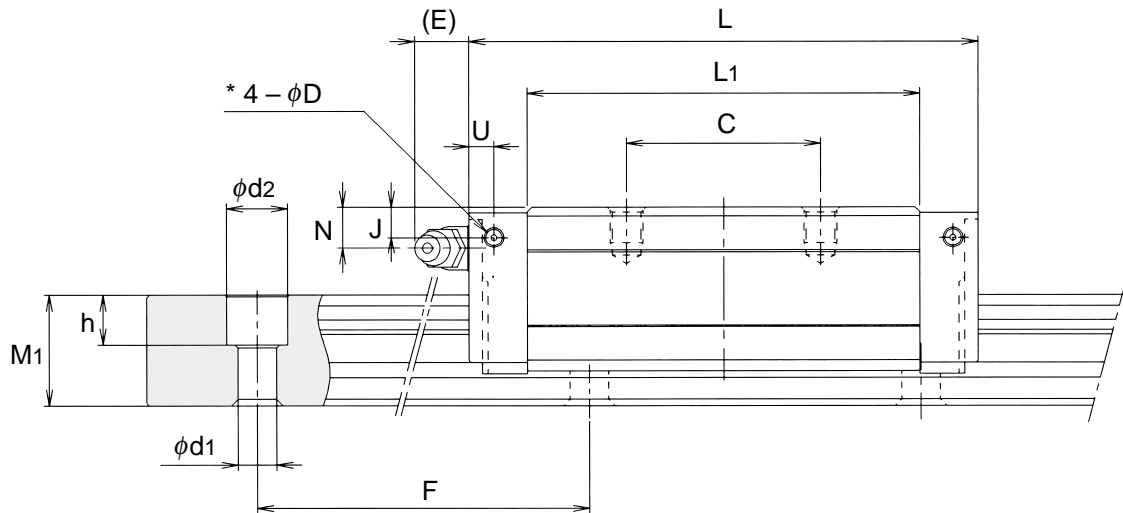

Unit : mm

Hole for side grease fitting*			LM rail dimensions					Basic load rating		Mass	
U	J	D	Width $W_1 \begin{smallmatrix} 0 \\ -0.05 \end{smallmatrix}$	$W_2$	Height $M_1$	Pitch $F$	$d_1 \times d_2 \times h$	C kN	$C_0$ kN	LM block kg	LM rail kg/m
4.2	4	3	15	9.5	13	60	4.5×7.5×5.3	14.2 17.2	24.2 31.9	0.19 0.22	1.3
5.7	5.3	3	20	12	16.5	60	6×9.5×8.5	22.3 28.1	38.4 50.3	0.35 0.46	2.3
4.5	5.5	3	23	12.5	20	60	7×11×9	31.7 36.8	52.4 64.7	0.54 0.67	3.2
7.5	6	5.2	28	16	23	80	9×14×12	44.8 54.2	66.6 88.8	0.94 1.16	4.5
8	5.5	5.2	34	18	26	80	9×14×12	62.3 72.9	96.6 127	1.4 1.84	6.2
9	8	5.2	45	20.5	32	105	14×20×17	82.8 100	126 166	2.54 3.19	10.4
10	8	5.2	53	23.5	38	120	16×23×20	128 161	197 259	4.05 5.23	14.5
13	12	5.2	63	31.5	53	150	18×26×22	205 253	320 408	8.41 10.7	23.7

\* Holes on the sides of the LM block for lubrication nipples are not made all the way through to prevent foreign materials from entering. Please contact  when using lubrication nipples.

# Compact Type

## Type SHS...R (Heavy load type)

## Type SHS...LR (Ultra heavy load type)

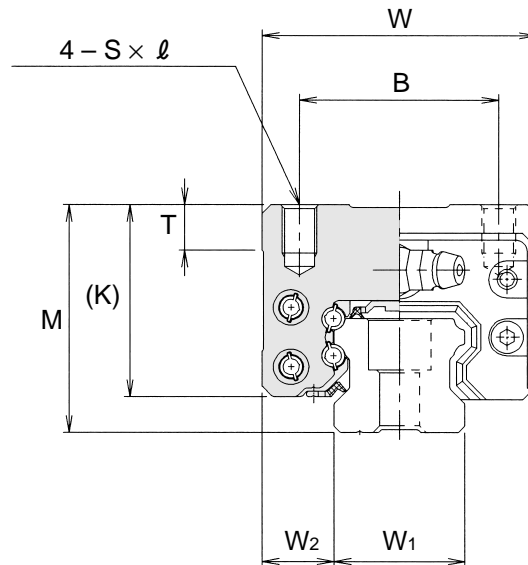

Model number	Outline dimensions			LM block dimensions									
	Height M	Width W	Length L	B	C	$S \times l$	$L_1$	T	K	N	E	Grease fitting	
SHS 15 R	28	34	64.4	26	26	M4×5	48	6	25	9.5	5.5	PB1021B	
SHS 25 R	40	48	92	35	35	M6×8	71	8	34.2	11.5	12	B-M6F	
SHS 25 LR			109				88						
SHS 30 R	45	60	106	40	40	M8×10	80	8.5	38	11	12	B-M6F	
SHS 30 LR			131				105						
SHS 35 R	55	70	122	50	50	M8×12	93	15	47.5	15	12	B-M6F	
SHS 35 LR			152				123						
SHS 45 R	70	86	140	60	60	M10×17	106	15	61.1	20.5	16	B-PT1/8	
SHS 45 LR			174				140						
SHS 55 R	80	100	171	75	75	M12×18	131	20	67.3	21	16	B-PT1/8	
SHS 55 LR			213				173						

Note: ·See page 8 for static permissible moment  $M_A$ ,  $M_B$ ,  $M_C$ .  
 ·See page 10 for the model number coding.  
 ·See page 16 for the standard LM rail lengths.

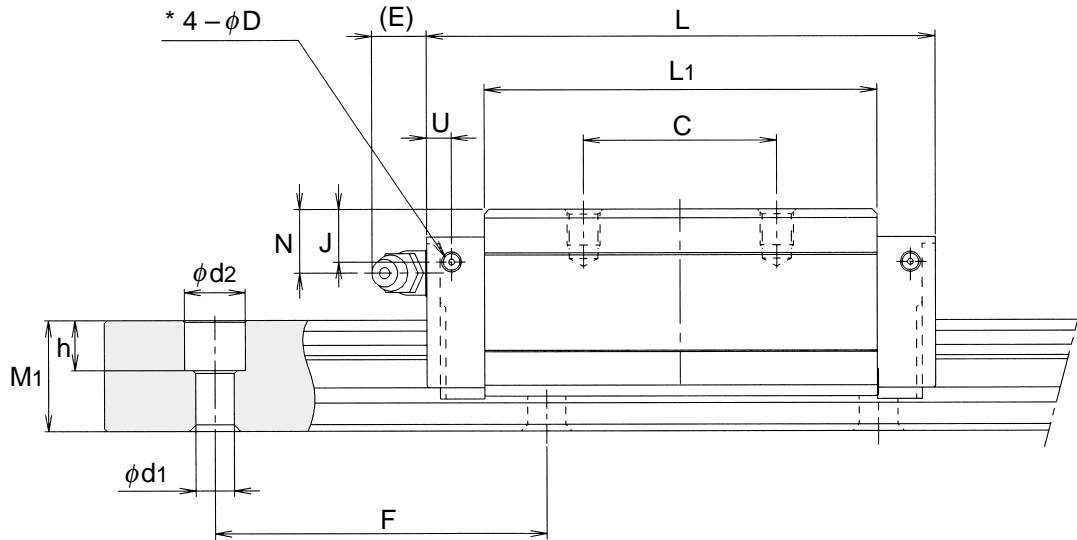

Unit : mm

Hole for side grease fitting*			LM rail dimensions					Basic load rating		Mass	
U	J	D	Width $W_1$ $0_{-0.05}$	$W_2$	Height $M_1$	Pitch $F$	$d_1 \times d_2 \times h$	C kN	$C_0$ kN	LM block kg	LM rail kg/m
4.2	8	3	15	9.5	13	60	4.5×7.5×5.3	14.2	24.2	0.22	1.3
4.5	9.5	3	23	12.5	20	60	7×11×9	31.7 36.8	52.4 64.7	0.66 0.8	3.2
7.5	9	5.2	28	16	23	80	9×14×12	44.8 54.2	66.6 88.8	1.04 1.36	4.5
8	12.5	5.2	34	18	26	80	9×14×12	62.3 72.9	96.6 127	1.8 2.34	6.2
9	18	5.2	45	20.5	32	105	14×20×17	82.8 100	126 166	3.24 4.19	10.4
10	18	5.2	53	23.5	38	120	16×23×20	128 161	197 259	5.05 6.57	14.5

\* Holes on the sides of the LM block for lubrication nipples are not made all the way through to prevent foreign materials from entering. Please contact  when using lubrication nipples.

# THK Four way equal load rating LM Guide<sup>®</sup> with Caged Ball<sup>™</sup> Technology

## SHS

### Notes on use

#### \*Precautions in handling the LM block

The LM block includes precision mold resin. When it is dropped or struck, it may be damaged. Please take great care in handling the LM block.

#### \*Using holes on the sides of the LM block for lubrication nipples

When it is necessary to use holes on the sides of the LM block for attachment of lubrication nipples, please contact THK. THK will install nipples on the LM block. (Holes are not made all the way through to prevent foreign materials from entering.)

These holes are for lubrication nipples only. Use of these holes for other purpose may break end plate.

#### \*Reinstalling the LM block

When the LM block is removed from the LM rail and then reinstalled, please insert it very carefully and correctly.

\*\*For reinstallation, we recommend that a special insertion jig is to be used. Please contact THK upon the use of jig.

#### \*Coolant

When the LM block is used in an environment in which some coolant may enter the LM block, some types of coolant may adversely affect the functions of the LM block. Please contact THK when selecting a coolant.

#### \*Operating temperature range

The LM block is made from special resin. Do not use it above 80°C.

#### \*Lubrication

Ordinary grease may not be utilized when the system is used in a special environment such as an area subject to extremes of temperature or continuous vibration, a clean room, or a vacuum environment. If the system is to be used in a special environment, please contact THK.

\*All right reserved.

\*Specifications are subject to change without notice.

## THK THK CO., LTD.

HEAD OFFICE 3-11-6, NISHI-GOTANDA, SHINAGAWA-KU, TOKYO 141-8503 JAPAN  
INTERNATIONAL SALES DEPARTMENT PHONE:(03)5434-0351 FAX:(03)5434-0353

#### U. S. A.

##### CHICAGO

PHONE:(847)310-1111 FAX:(847)310-1182

##### NEW JERSEY

PHONE:(201)529-1950 FAX:(201)529-1962

##### LOS ANGELES

PHONE:(714)891-6752 FAX:(714)894-9315

##### SAN FRANCISCO

PHONE:(925)455-8948 FAX:(925)455-8965

##### ATLANTA

PHONE:(770)840-7990 FAX:(770)840-7897

##### DETROIT

PHONE:(248)858-9330 FAX:(248)858-9455

##### BOSTON

PHONE:(781)575-1151 FAX:(781)575-9295

##### INDIANAPOLIS

PHONE:(317)243-3496 FAX:(317)243-3499

##### MINNEAPOLIS

PHONE:(612)953-4442 FAX:(612)953-4441

#### CANADA (TORONTO)

PHONE:(905)712-2922 FAX:(905)712-2925

#### BRASIL (SÃO PAULO)

PHONE:(011)3924-0911 FAX:(011)3924-0900

#### GERMANY

##### DÜSSELDORF

PHONE:(02102)74250 FAX:(02102)7425299

##### STUTTGART

PHONE:(07141)2757-0 FAX:(07141)2757-90

##### U.K. (MILTON KEYNES)

PHONE:(01908)222159 FAX:(01908)222161

##### FRANCE (LYON)

PHONE:(0437)49.14.00 FAX:(0437)49.14.01

##### ITALY (MILAN)

PHONE:(039)2842079 FAX:(039)2842527

##### SWEDEN (STOCKHOLM)

PHONE:(08)4457630 FAX:(08)4457639

##### AUSTRIA (LINZ)

PHONE:(07229)51400 FAX:(07229)51400-79

##### SPAIN (BARCELONA)

PHONE:(093)652-5740 FAX:(093)652-5746

##### PGM BALLSCREWS LIMITED (COVENTRY)

PHONE:(02476)841900 FAX:(02476)611032

##### PGM BALLSCREWS IRELAND LIMITED (DUBLIN)

PHONE:(01)4628101 FAX:(01)4629080

#### TAIWAN

##### TAIPEI

PHONE:(02)2585-8554 FAX:(02)2585-8495

##### TAICHUNG

PHONE:(04)2359-1505 FAX:(04)2359-1506

#### CHINA

##### BEIJING

PHONE:(10)6590-3557 FAX:(10)6590-3557

##### HONG KONG

PHONE:23761091, 23761252 FAX:23760749

##### MALAYSIA (KUALA LUMPUR)

PHONE:(03)987-1137 FAX:(03)987-8071

##### INDIA (BANGALORE)

PHONE:(080)330-1524 FAX:(080)330-1524

##### KOREA (SEOUL)

PHONE:(02)3463-0351 FAX:(02)3017-0351

