

ACTUATOR  
UNITS

**NEW**

# Universal series

US/USW



For details, visit THK at [www.thk.com](http://www.thk.com)

\* Product information is updated regularly on the THK website.

**THK CO., LTD.**  
TOKYO, JAPAN

CATALOG No.377-11E

Electrical Actuator  
Universal Series  
US/USW

# High Speed, High Load Capacity, Long Service Life

## US

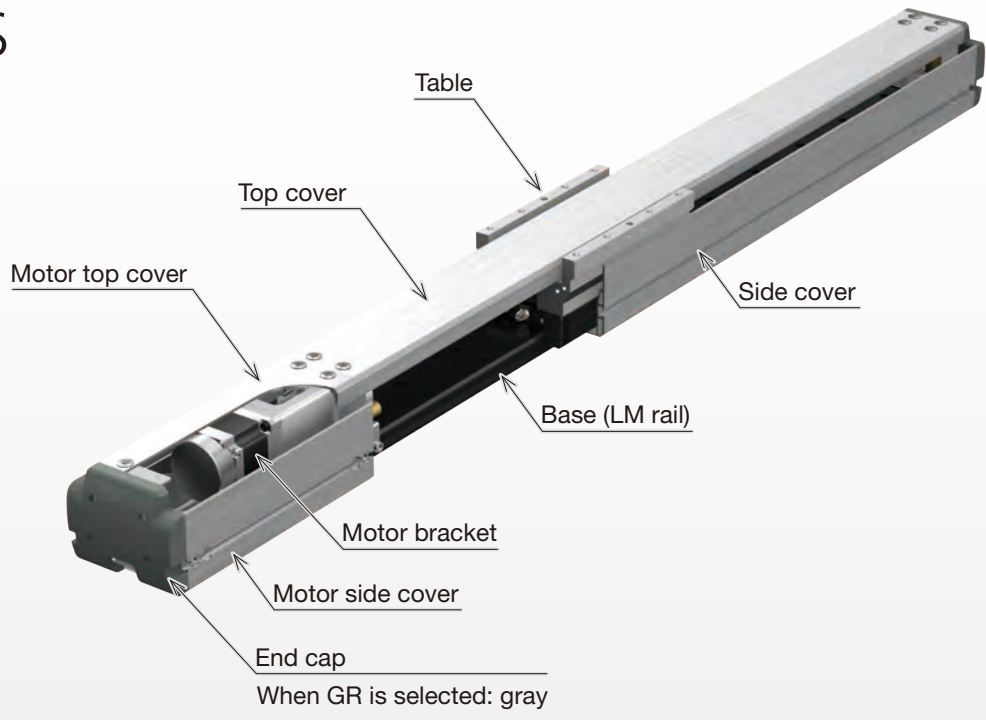

## USW

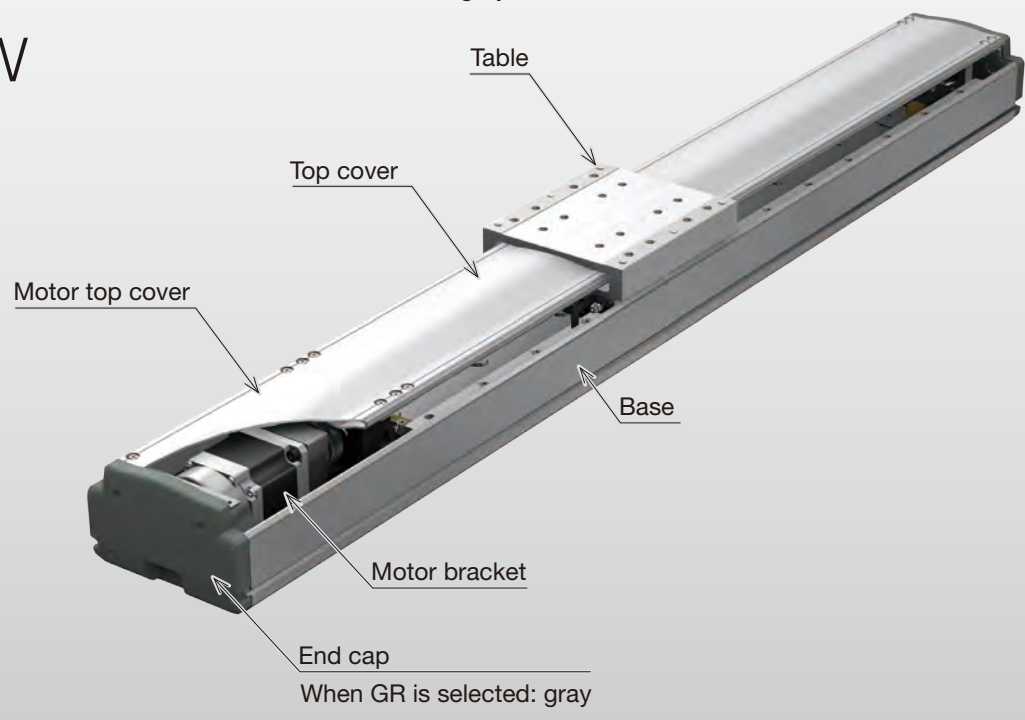

Size range by model

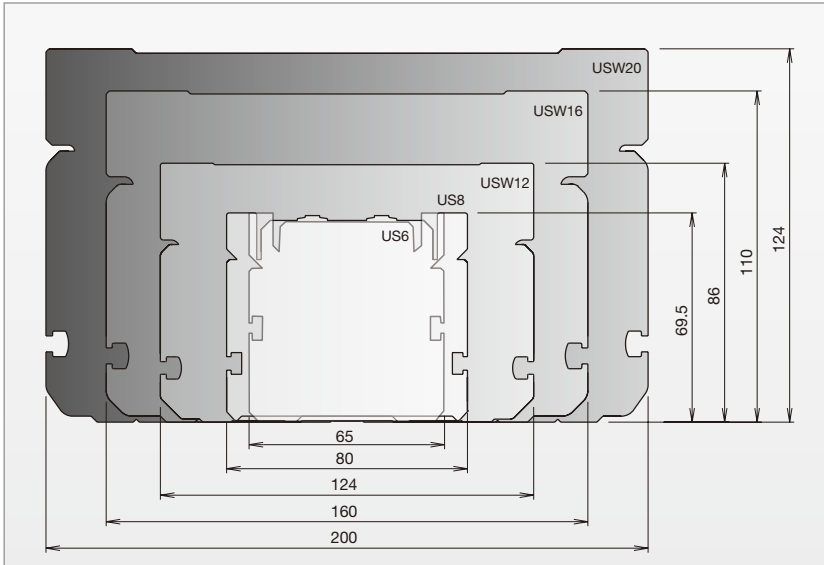

## Features

### Long service life

Most US models have a running life of 20,000km with the maximum load capacity applied (10,000km for US6 and 8), which is the highest level of service life in the industry. LM Guide and ball screw running life can also be calculated based on usage conditions.

### Long-term maintenance-free operation

Thanks to the use of Caged Ball LM Guide model SRS (US6), SHW (US8) and model SHS (USW12, 16, and 20) in a rectilinear guide, and Lubricator QZ, which supplies just the right amount of lubricant in the ball screw, this series provides long-term maintenance-free operation.

### High speed

Most units in this series (US8 to USW20) accommodate twice as many types of leads for each ball screw shaft diameter. This reduces processing time and enables the device to operate at high speeds.

### Smart structure

In most units the standard sensor is incorporated into the actuator, making the actuator highly compact (this does not apply to the US6). For other sensor options, the sensor is installed on the outside of the unit. US8: 1 sensor (home position); USW12, 16, and 20: 3 sensors (home position and ends).

### Easy assembly

For the standard unit, both table and base have dowel pin holes, and the base has elongated holes. These facilitate installation and assembly, enabling the unit to be mounted easily. Either top face mounting or lower face mounting can be selected for the base (this applies to USW12, 16, and 20 only).

### Versatile lineup

These units accommodate stroke lengths, specified in 50mm increments, ranging from 100mm to 1,700mm. Many types of ball screw leads are provided as well, enabling customers to select a unit ideally suited to their needs.

## Lineup List

[ With ball screw ]

Direct motor coupling type



Ball screw and motor are connected using a coupling.

[ With ball screw ]

Motor wrap type



Motor can be wrapped laterally to reduce the axial dimension.

Model	Ball screw lead [mm]	Stroke [mm]	Motor rated output [W]						
				100	200	300	400	500	600
US6	6	100 to 900	50	360					310
	12			720					630
	6		100	360					310
	12			720					630
US8	5	100 to 1100	100	300					
	10			600					
	20			1200					
	30		150	1800					
	10			600					
	20			1200					
	30			1800					
USW12	5	100 to 1100	200	300					
	10			600					580
	20			1200					1160
	30			1800					1700
USW16	10	100 to 1500	400	550					
	20			1100					
	40			2200					
USW20	20	200 to 1700	750	1100					
	40			2200					

\*1 The maximum speed is the value restricted by the motor rotational speed (US6 to USW12: at 3,600 min<sup>-1</sup>, USW16 to USW20: 3,300 min<sup>-1</sup>), or by the permissible rotational speed of the ball screw.

Maximum speed [mm/s] *1 for each stroke [mm]																	Described on							
Stroke [mm]																								
	700		800		900		1000		1100		1200		1300		1400		1500		1600		1700			
	270	240	210	180	160																		Page 7	
	550	480	420	370	330																			
	270	240	210	180	160																			
	550	480	420	370	330																			
	290	250	220	200	180	160	150	130	120															Page 15
	550	480	430	380	340	310	280	250	230															
	1090	960	850	760	680	610	560	510	460															
	1600	1410	1250	1120	1000	910	820	750	690															
	550	480	430	380	340	310	280	250	230															Page 23
	1090	960	850	760	680	610	560	510	460															
	1600	1410	1250	1120	1000	910	820	750	690															
	270	240	210	190	170	150	140	130	120															
	510	450	400	360	320	290	260	240	220															
	1020	900	800	720	640	580	530	480	440															
	1490	1320	1180	1050	950	860	780	720	660															
			520	470	420	380	340	310	290	260	240	230	210	190	180	170	160							Page 39
			1040	930	840	760	700	640	590	540	500	460	430	400	380	350								
			1970	1780	1610	1470	1340	1230	1130	1050	970	900	840	780	730	690								
			1010	910	820	750	680	620	570	530	490	460	420	400	370	350	330	310	290	270				
			2140	1920	1730	1570	1430	1310	1210	1110	1030	950	890	830	770	720	680	640	600	570	530			

Model Configuration

Model	Ball screw lead	Stroke	Design symbol	With/without motor	Sensor	Sensor mounting position
USW12RT	05	0150	A	0	6	SR
(1)	(2)	(3)	(4)	(5)	(6)	(7)

US6T	05: 5mm	0100: 100mm	A	0 : Without motor	P	No symbol: When selecting P, Q, or N
US8T	06: 6mm	0150: 150mm		0B: Without motor (With brake)	Q	SR: On right side as seen from side A
USW12T	10: 10mm	0200: 200mm		1 : With motor (Prepared by THK)	N	SL: On left side as seen from side A
USW16T	12: 12mm	to		1B: With motor (Prepared by THK, with brake)	6	
USW20T	20: 20mm	1700: 1700mm			E	
US6RT	30: 30mm				J	
US8RT	40: 40mm				M	

R represents motor wrap.

Note: For US6, the maximum stroke for horizontal and vertical types is 900mm; for wall mount type, 800mm.

Note: When motor wrap is selected, a sensor cannot be mounted on the same side as the motor wrap direction of the motor.

Ball screw leads you can select differ depending on models.

US6 : 06, 12  
 US8 : 05, 10, 20, 30  
 USW12: 05, 10, 20, 30  
 USW16: 10, 20, 40  
 USW20: 20, 40

For US8 with 150W motor capacity, you cannot select the ball screw lead 05.

When 0 or 0B is selected:  
 Direct motor coupling type: A coupling is not provided.  
 Motor wrap type: Timing pulley and timing belt are provided.

When 1 or 1B is selected:  
 Direct motor coupling type: Mounted parts: motor, coupling, power cable, encoder cable, electromagnetic brake cable.  
 Motor wrap type: Mounted parts: motor, timing belt, timing pulley  
 Accessories: power cable, encoder cable, electromagnetic brake cable.

The customer selects the desired motor, coupling, and cables. Recommended coupling is available; see the "Recommended Coupling" section.

Pages for detailed description

(6) Sensors	P. 47
(9) Motor bracket	P. 48

Base mounting method	Motor bracket	Option
<b>C</b> (8)	<b>A</b> (9)	<b>MR-GR</b> (10)
<p><b>T</b>: From underside of base (tapped holes)</p> <p><b>C</b>: From top of base (counter-bore holes)</p>	<p><b>A</b></p> <p><b>B</b></p> <p><b>C</b></p>	<p><b>No symbol</b>: Red end cap</p> <p><b>MR</b>: Motor right wrap</p> <p><b>ML</b>: Motor left wrap</p> <p><b>GR</b>: Change the end cap color to gray</p> <p><b>HG</b>: Hanging jig</p>

For US6 and US8, you only can select "C".

If you select motor wrap for model (1), select either MR or ML. Changing end cap color: You can change the color of an end cap to gray. However, for motor wrap, this change is only applied to an end cap on the reverse motor side.

No symbol: red

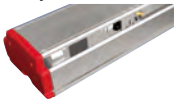

When GR is selected: gray



You can select a hanging jig only when selecting USW12, USW16 or USW20.

If the GR is not included in the model configuration, and cap will be red.

**Motor wrap direction**

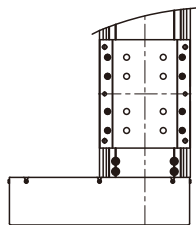

Option symbol ML: Motor left wrap

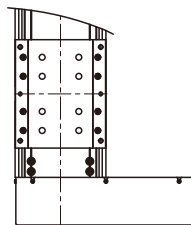

Option symbol MR: Motor right wrap

# US6T Direct motor coupling

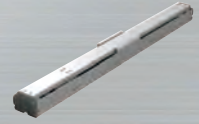

## Model Configuration

Model	Ball screw lead	Stroke	Design symbol	With/without motor	Sensor	Sensor mounting position
US6T	06	0150	A	0	6	SR

US6T	06: 6mm	0100: 100mm	A	0 : Without motor	N	No symbol: When selecting N
	12: 12mm	to		0B: Without motor (With brake)	6	SR
		0900: 900mm		1 : With motor (Prepared by THK)	E	SL
				1B: With motor (Prepared by THK, with brake)	J	
					M	

Note: For US6, the maximum stroke for horizontal and vertical types is 900mm; for a wall mount type, 800mm.

## Reference Basic Specifications

Motor rated output [W]		50		100	
Ball screw lead [mm]		6	12	6	12
Rated speed * <sup>1</sup> [mm/s]		300	600	300	600
Maximum load capacity * <sup>2</sup> [kg]	Acceleration and deceleration rate	Horizontal mount	0.3G	30	15
	Vertical mount	0.3G	7	3	14
Rated thrust * <sup>3</sup> [N]		134	67	268	134
Maximum thrust * <sup>4</sup> [N]		402	201	795	398
Electromagnetic brake retention [N]		268	134	268	134
Running life * <sup>5</sup> [km]		10,000			
Static permissible moment * <sup>6</sup> [N·m]		M <sub>A</sub> : 123, M <sub>B</sub> : 127, M <sub>C</sub> : 138			
Positioning repeatability [mm]		±0.020			
Backlash [mm]		0.05			

Static permissible moment

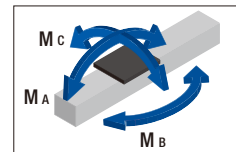

\*<sup>1</sup> At rated motor speed (3,000 min<sup>-1</sup>).

\*<sup>2</sup> Load capacity and maximum speed are dependent on usage conditions.

\*<sup>3</sup> At rated motor torque.

\*<sup>4</sup> Dependent on maximum peak torque and permissible load.

\*<sup>5</sup> Conditions:

Stroke: 100mm

Acceleration and deceleration rate: 0.3G

Maximum speed: maximum speed or top speed for stroke length and acceleration and deceleration rate

Applied load: maximum load capacity

Center of gravity: center of top surface of table.

\*<sup>6</sup> Static maximum permissible moment when unit is stationary. Moment standards: M<sub>A</sub> and M<sub>C</sub>: top of table; M<sub>B</sub>: center of table.



# US6T

Base mounting method	Motor bracket	Option
C	A	GR

C: From top of base (counter-base holes)

A

No symbol: Red end cap  
GR: Gray end cap

## Reference Permissible Overhang Length\*

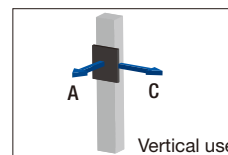
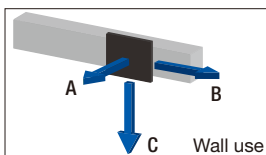
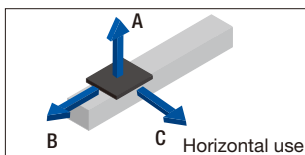

Horizontal mount [mm]

Ball screw lead [mm]	Load mass [kg]	A	B	C
6	17	730	210	230
	35	350	100	110
	70	170	40	40
12	7	1110	470	420
	15	630	240	210
	30	330	110	100

Wall mount [mm]

Ball screw lead [mm]	Load mass [kg]	A	B	C
6	7	460	410	1640
	15	210	180	940
	30	70	60	440
12	7	410	410	1000
	15	190	180	520
	30	60	60	220

Vertical mount [mm]

Ball screw lead [mm]	Load mass [kg]	A	C
6	1	1550	1540
	7	450	440
	14	220	220
12	1	1440	1430
	4	630	620
	7	400	400

\* Dependent on running life of LM guide (10,000km) and on static permissible moment.

The conditions for calculation are as follows:

Stroke: 100mm

Acceleration and deceleration rate: 0.3G

Maximum speed: maximum speed or top speed for stroke length and acceleration and deceleration rate

Applied load: maximum load capacity.

A, B, and C represent distances measured from the center of the top surface of the table.

# US6T Direct motor coupling

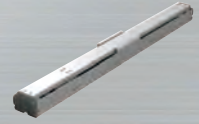

## Dimensions

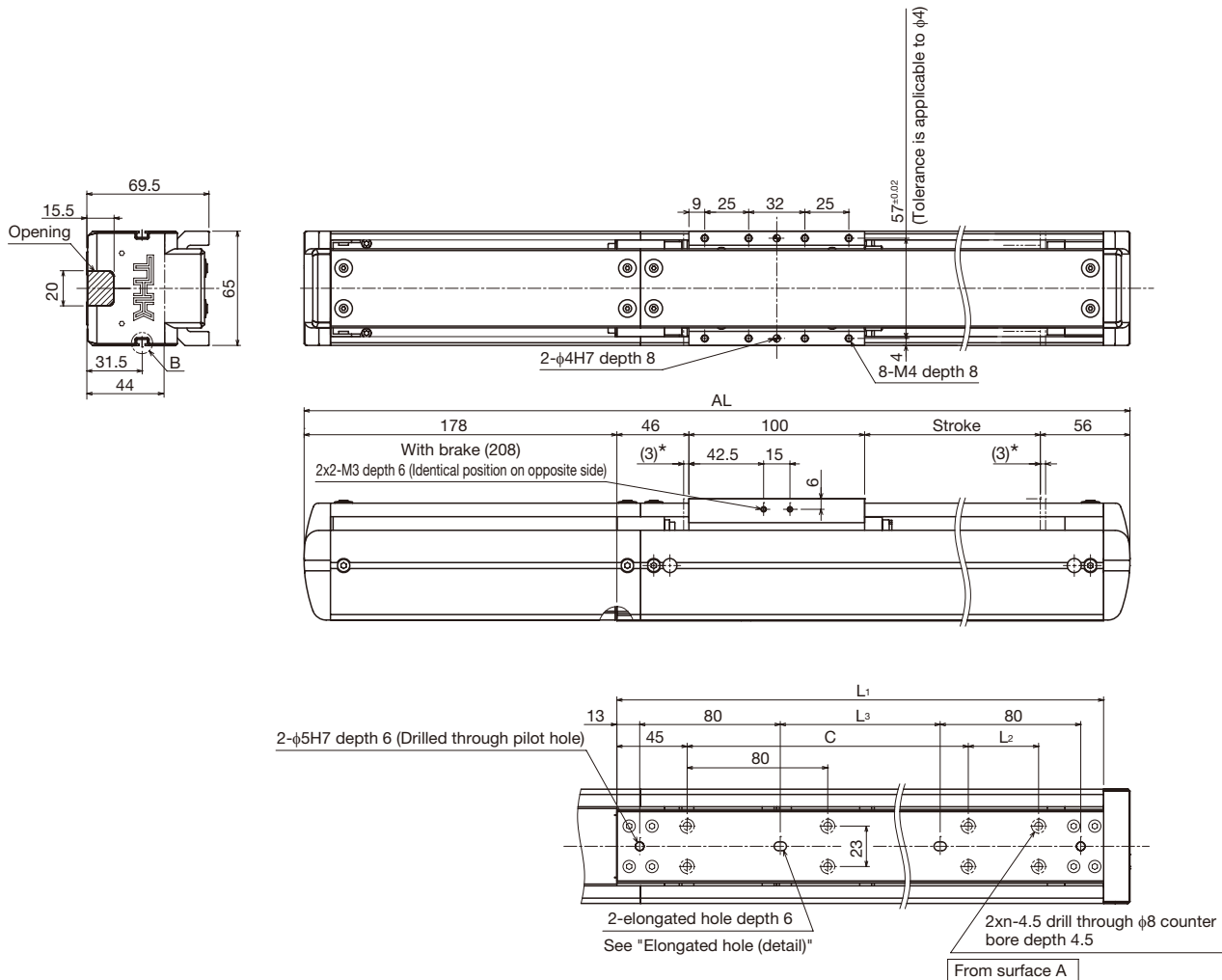

\* Stroke up to mechanical stopper.

Stroke [mm] (Stroke between mechanical stoppers)		100 (106)	150 (156)	200 (206)	250 (256)	300 (306)	350 (356)	400 (406)		
Maximum speed [mm/s]	Ball screw lead: 6mm								360	
	Ball screw lead: 12mm								720	
Dimensions [mm]	AL <sup>*3</sup>	480 (510)	530 (560)	580 (610)	630 (660)	680 (710)	730 (760)	780 (810)		
	L <sub>1</sub>	287	337	387	437	487	537	587		
	L <sub>2</sub>	40	-	40	40	-	40	-		
	L <sub>3</sub>	101	151	201	251	301	351	401		
Mounting hole count	n	4	4	5	6	6	7	7		
Weight [kg]		3.0	3.2	3.4	3.6	3.8	4.1	4.3		

\*<sup>1</sup> Load capacity and maximum speed vary.

\*<sup>2</sup> The maximum speed is the value restricted by the permissible rotational speed of the ball screw.

\*<sup>3</sup> Values when a brake is installed are shown in parentheses.

# US6T

## Detail

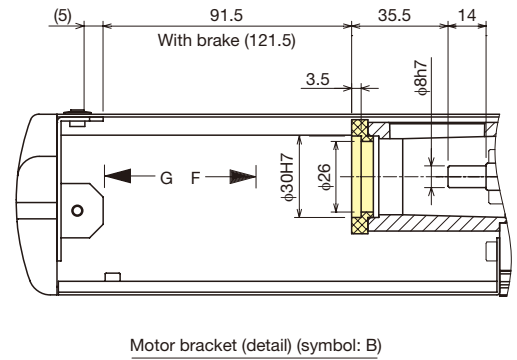
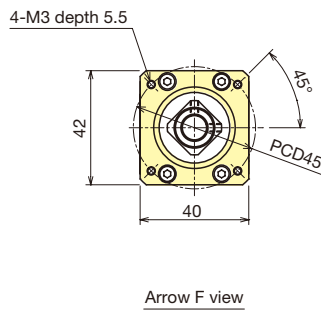
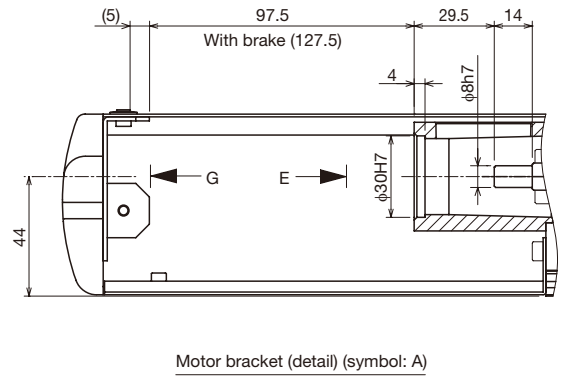
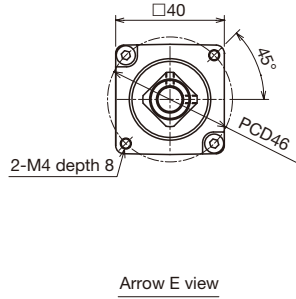
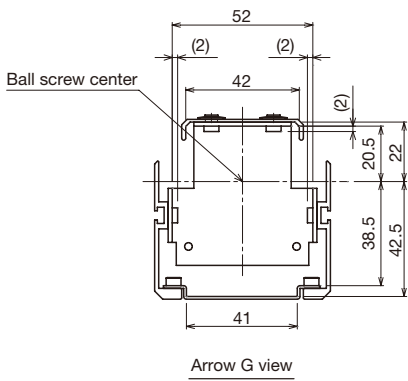

See page 48, "Motor Brackets," for a list of applicable motors.

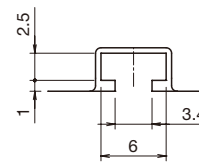
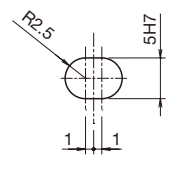
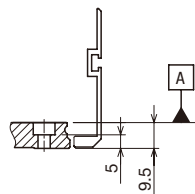

	450 (456)	500 (506)	550 (556)	600 (606)	650 (656)	700 (706)	750 (756)	800 (806)	850 (856)	900 (906)
	360				310	270	240	210	180	160
	720				630	550	480	420	370	330
	830 (860)	880 (910)	930 (960)	980 (1010)	1030 (1060)	1080 (1110)	1130 (1160)	1180 (1210)	1230 (1260)	1280 (1310)
	637	687	737	787	837	887	937	987	1037	1087
	-	40	-	40	40	-	40	-	-	40
	451	501	551	601	651	701	751	801	851	901
	560	560	640	640	720	800	800	880	960	960
	8	9	9	10	11	11	12	12	13	14
	4.5	4.7	4.9	5.1	5.3	5.5	5.7	5.9	6.2	6.4

# US6RT Motor wrap



## Model Configuration

Model	Ball screw lead	Stroke	Design symbol	With/without motor	Sensor	Sensor mounting position
US6RT	06	0150	A	0	6	SL

US6RT	06: 6mm	0100: 100mm	A	0 : Without motor	N	No symbol: When selecting N
	12: 12mm	to		0B: Without motor (With brake)	6	SR
		0900: 900mm		1 : With motor (Prepared by THK)	E	SL
				1B: With motor (Prepared by THK, with brake)	J	
					M	

Note: For US6, the maximum stroke for horizontal and vertical types is 900mm; for a wall mount type, 800mm.

## Reference Basic Specifications

Motor rated output [W]		50		100			
Ball screw lead [mm]		6	12	6	12		
Rated speed <sup>*1</sup> [mm/s]		300	600	300	600		
Maximum load capacity <sup>*2</sup> [kg]	Acceleration and deceleration rate	Horizontal mount	0.3G	30	15	70	30
	Vertical mount	0.3G	7	3	14	7	
Rated thrust <sup>*3</sup> [N]		134	67	268	134		
Maximum thrust <sup>*4</sup> [N]		402	201	795	398		
Electromagnetic brake retention [N]		268	134	268	134		
Running life <sup>*5</sup> [km]		10,000					
Static permissible moment <sup>*6</sup> [N·m]		M <sub>A</sub> : 123, M <sub>B</sub> : 127, M <sub>C</sub> : 138					
Positioning repeatability [mm]		±0.020					
Backlash [mm]		0.05					

Static permissible moment

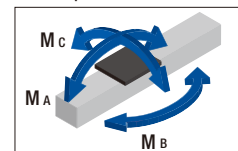

<sup>\*1</sup> At rated motor speed (3,000 min<sup>-1</sup>).

<sup>\*2</sup> Load capacity and maximum speed are dependent on usage conditions.

<sup>\*3</sup> At rated motor torque.

<sup>\*4</sup> Dependent on maximum peak torque and permissible load.

<sup>\*5</sup> Conditions:

Stroke: 100mm

Acceleration and deceleration rate: 0.3G

Maximum speed: maximum speed or top speed for stroke length and acceleration and deceleration rate

Applied load: maximum load capacity

Center of gravity: center of top surface of table.

<sup>\*6</sup> Static maximum permissible moment when unit is stationary. Moment standards: M<sub>A</sub> and M<sub>C</sub>: top of table; M<sub>B</sub>: center of table.

# US6RT

Base mounting method	Motor bracket	Option
C	A	MR-GR

C: From top of base (counter-base holes)

A
B

MR: Motor right wrap
ML: Motor left wrap
GR: Gray end cap

Note: If the GR is not included in the model configuration, cover will be red.

## Reference Permissible Overhang Length\*

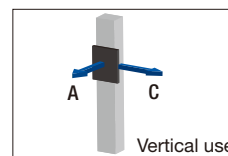
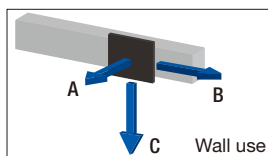
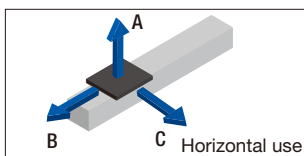

Horizontal mount [mm]

Ball screw lead [mm]	Load mass [kg]	A	B	C
6	17	730	210	230
	35	350	100	110
	70	170	40	40
12	7	1110	470	420
	15	630	240	210
	30	330	110	100

Wall mount [mm]

Ball screw lead [mm]	Load mass [kg]	A	B	C
6	7	460	410	1640
	15	210	180	940
	30	70	60	440
12	7	410	410	1000
	15	190	180	520
	30	60	60	220

Vertical mount [mm]

Ball screw lead [mm]	Load mass [kg]	A	C
6	1	1550	1540
	7	450	440
	14	220	220
12	1	1440	1430
	4	630	620
	7	400	400

\* Dependent on running life of LM guide (10,000km) and on static permissible moment.

The conditions for calculation are as follows:

Stroke: 100mm

Acceleration and deceleration rate: 0.3G

Maximum speed: maximum speed or top speed for stroke length and acceleration and deceleration rate

Applied load: maximum load capacity.

A, B, and C represent distances measured from the center of the top surface of the table.

# US6RT Motor wrap



## Dimensions

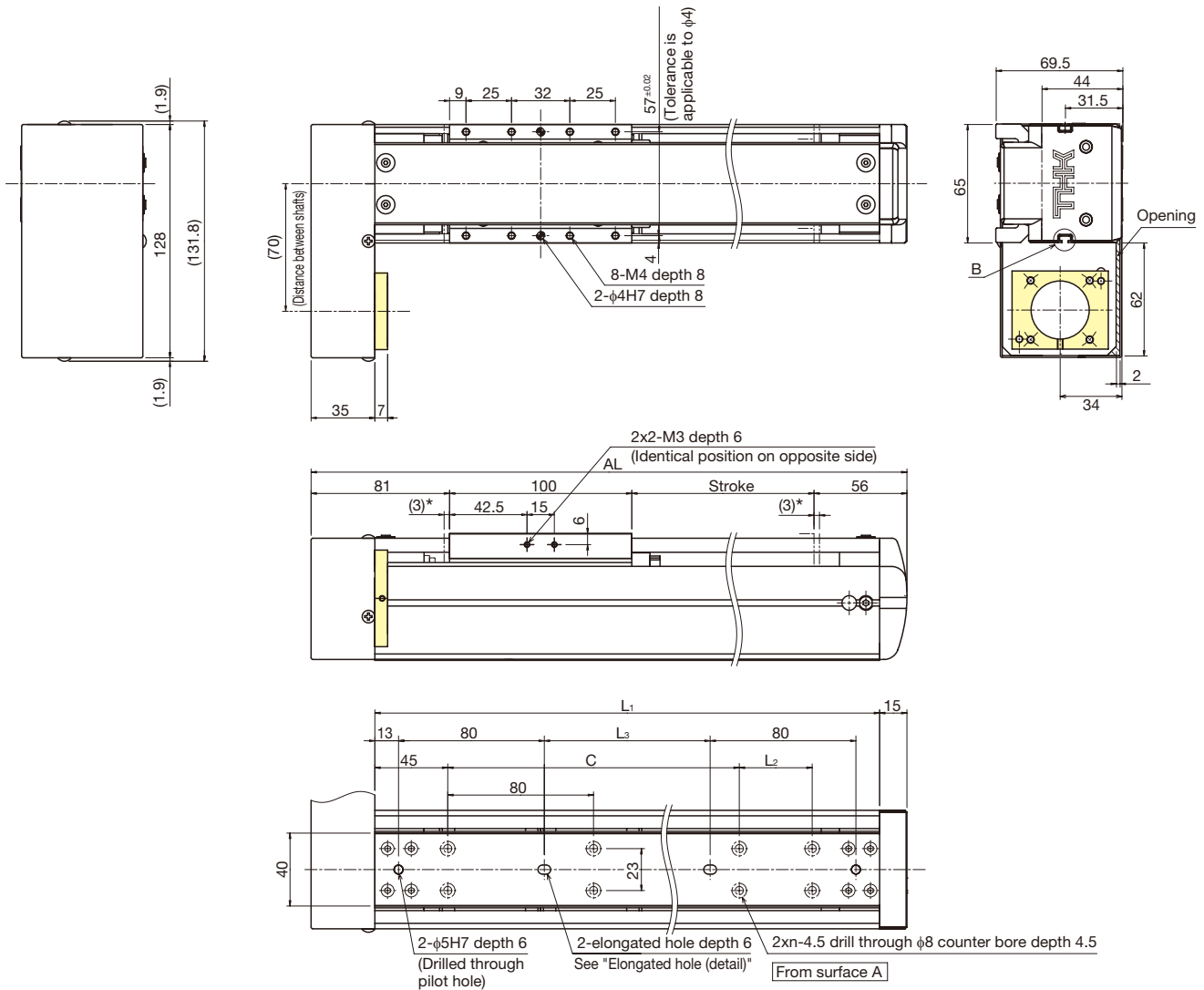

\* Stroke up to mechanical stopper.

Stroke [mm] (Stroke between mechanical stoppers)		100 (106)	150 (156)	200 (206)	250 (256)	300 (306)	350 (356)	400 (406)	
Maximum speed <sup>*1 *2</sup> [mm/s]	Ball screw lead: 6mm				360				
	Ball screw lead: 12mm				720				
Dimensions [mm]	AL	337	387	437	487	537	587	637	
	L <sub>1</sub>	287	337	387	437	487	537	587	
	L <sub>2</sub>	40	-	40	40	-	40	-	
	L <sub>3</sub>	101	151	201	251	301	351	401	
Mounting hole count	n	4	4	5	6	6	7	7	
Weight [kg]		3.0	3.2	3.4	3.6	3.8	4.0	4.2	

\*<sup>1</sup> Load capacity and maximum speed vary.

\*<sup>2</sup> The maximum speed is the value restricted by the permissible rotational speed of the ball screw.

# US6RT

## Detail

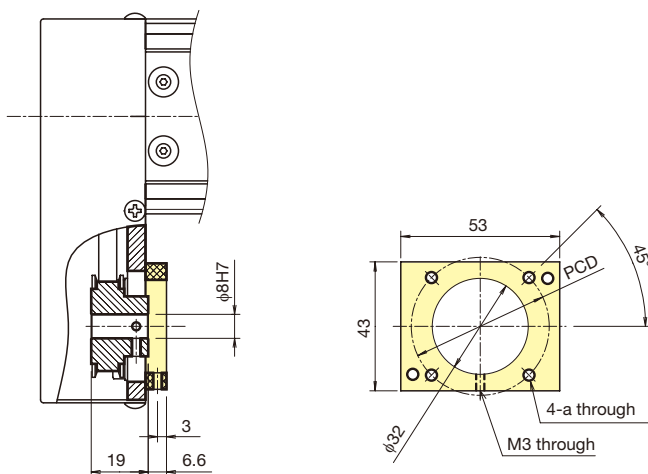

■ Motor bracket specifications [mm]

Symbol	a	PCD
A	M4	46
B	M3	45

Motor bracket (detail) (symbol: A, B)

See page 48, "Motor Brackets," for a list of applicable motors.

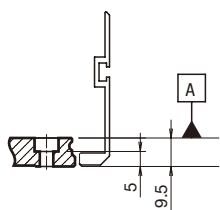

Counter-bore hole on base (detail)

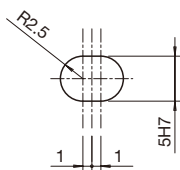

Elongated hole (detail)

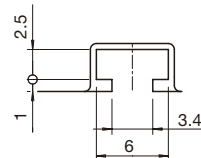

Section B (detail)

	450 (456)	500 (506)	550 (556)	600 (606)	650 (656)	700 (706)	750 (756)	800 (806)	850 (856)	900 (906)
			360		310	270	240	210	180	160
			720		630	550	480	420	370	330
	687	737	787	837	887	937	987	1037	1087	1137
	637	687	737	787	837	887	937	987	1037	1087
	-	40	-	40	40	-	40	-	-	40
	451	501	551	601	651	701	751	801	851	901
	560	560	640	640	720	800	800	880	960	960
	8	9	9	10	11	11	12	12	13	14
	4.4	4.7	4.9	5.1	5.3	5.5	5.7	5.9	6.1	6.3

# US8T Direct motor coupling

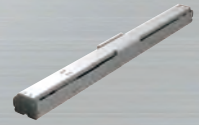

## Model Configuration

Model	Ball screw lead	Stroke	Design symbol	With/without motor	Sensor	Sensor mounting position
US8T	05	0150	A	0	6	SR

<b>US8T</b>	<b>05:</b> 5mm	<b>0100:</b> 100mm	<b>A</b>	<b>0</b> : Without motor	<b>P</b>	<b>No symbol:</b> When selecting P, Q, or N
	<b>10:</b> 10mm	to		<b>0B:</b> Without motor (With brake)		
	<b>20:</b> 20mm	<b>1100:</b> 1100mm	<b>1</b> : With motor (Prepared by THK)	<b>Q</b>		
	<b>30:</b> 30mm		<b>1B:</b> With motor (Prepared by THK, with brake)	<b>N</b>		
				<b>6</b>	<b>E</b>	<b>SR</b>
					<b>J</b>	<b>SL</b>
					<b>M</b>	

## Reference Basic Specifications

Motor rated output [W]		100				150					
Ball screw lead [mm]		5	10	20	30	10	20	30			
Rated speed <sup>*1</sup> [mm/s]		250	500	1000	1500	500	1000	1500			
Maximum load capacity <sup>*2</sup> [kg]	Acceleration and deceleration rate	0.3G	Horizontal mount	0.3G	80	40	20	8	60	30	12
	Vertical mount				0.3G	16 <sup>*3</sup>	8	4	2	12	6
Rated thrust <sup>*4</sup> [N]		322	161	80	54	240	120	80			
Maximum thrust <sup>*5</sup> [N]		955	478	239	159	719	359	240			
Electromagnetic brake retention [N]		322	161	80	54	161	80	54			
Running life <sup>*6</sup> [km]		10,000									
Static permissible moment <sup>*7</sup> [N·m]		M <sub>A</sub> : 287, M <sub>B</sub> : 235, M <sub>C</sub> : 226									
Positioning repeatability [mm]		±0.020									
Backlash [mm]		0.05									

Static permissible moment

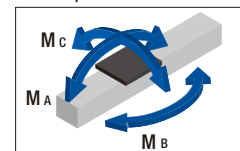

<sup>\*1</sup> At rated motor speed (3,000 min<sup>-1</sup>).

<sup>\*2</sup> Load capacity and maximum speed are dependent on usage conditions.

<sup>\*3</sup> When acceleration and deceleration rate is 0.2G.

<sup>\*4</sup> At rated motor torque.

<sup>\*5</sup> Dependent on maximum peak torque and permissible load.

<sup>\*6</sup> Conditions:

Stroke: 100mm

Acceleration and deceleration rate: 0.3G (ball screw lead 5mm, 0.2G vertical only)

Maximum speed: maximum speed or top speed for stroke length and acceleration and deceleration rate

Applied load: maximum load capacity

Center of gravity: center of top surface of table.

<sup>\*7</sup> Static maximum permissible moment when unit is stationary. Moment standards: M<sub>A</sub> and M<sub>C</sub>: top of table; M<sub>B</sub>: center of table.



Base mounting method	Motor bracket	Option
C	A	GR

C: From top of base (counter-base holes)

A
B

No symbol : Red end cap
GR : Gray end cap

Note: If the GR is not included in the model configuration, cover will be red.

### Reference Permissible Overhang Length\*

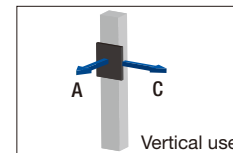
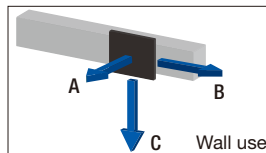
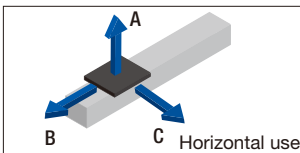

Horizontal mount [mm]

Ball screw lead [mm]	Load mass [kg]	A	B	C
5	20	1610	370	340
	40	970	190	170
	80	520	80	70
10	20	1190	370	310
	40	680	190	150
	60	340	120	100
20	10	1860	660	560
	20	1190	370	310
	30	870	190	210
30	4	2000	1220	1070
	8	2000	780	670
	12	1670	570	490

Wall mount [mm]

Ball screw lead [mm]	Load mass [kg]	A	B	C
5	20	280	310	1410
	40	120	120	750
	80	20	20	250
10	20	280	310	1010
	40	120	120	510
	60	50	60	290
20	10	550	590	1690
	20	280	310	1010
	30	170	190	700
30	4	1080	1150	2000
	8	660	710	1940
	12	470	510	1490

Vertical mount [mm]

Ball screw lead [mm]	Load mass [kg]	A	C
5	4	1190	1180
	8	760	750
	16	440	430
10	4	1150	1140
	8	720	720
	12	530	520
20	2	1690	1680
	4	1150	1140
	6	890	880
30	1	2000	2000
	2	1690	1680
	3	1360	1350

\*Dependent on running life of LM guide (10,000km) and on static permissible moment.

The conditions for calculation are as follows:

Stroke: 100mm

Acceleration and deceleration rate: 0.3G

Maximum speed: maximum speed or top speed for stroke length and acceleration and deceleration rate

Applied load: maximum load capacity.

A, B, and C represent distances measured from the center of the top surface of the table.

# US8T Direct motor coupling

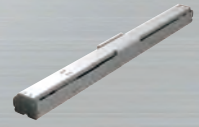

## Dimensions

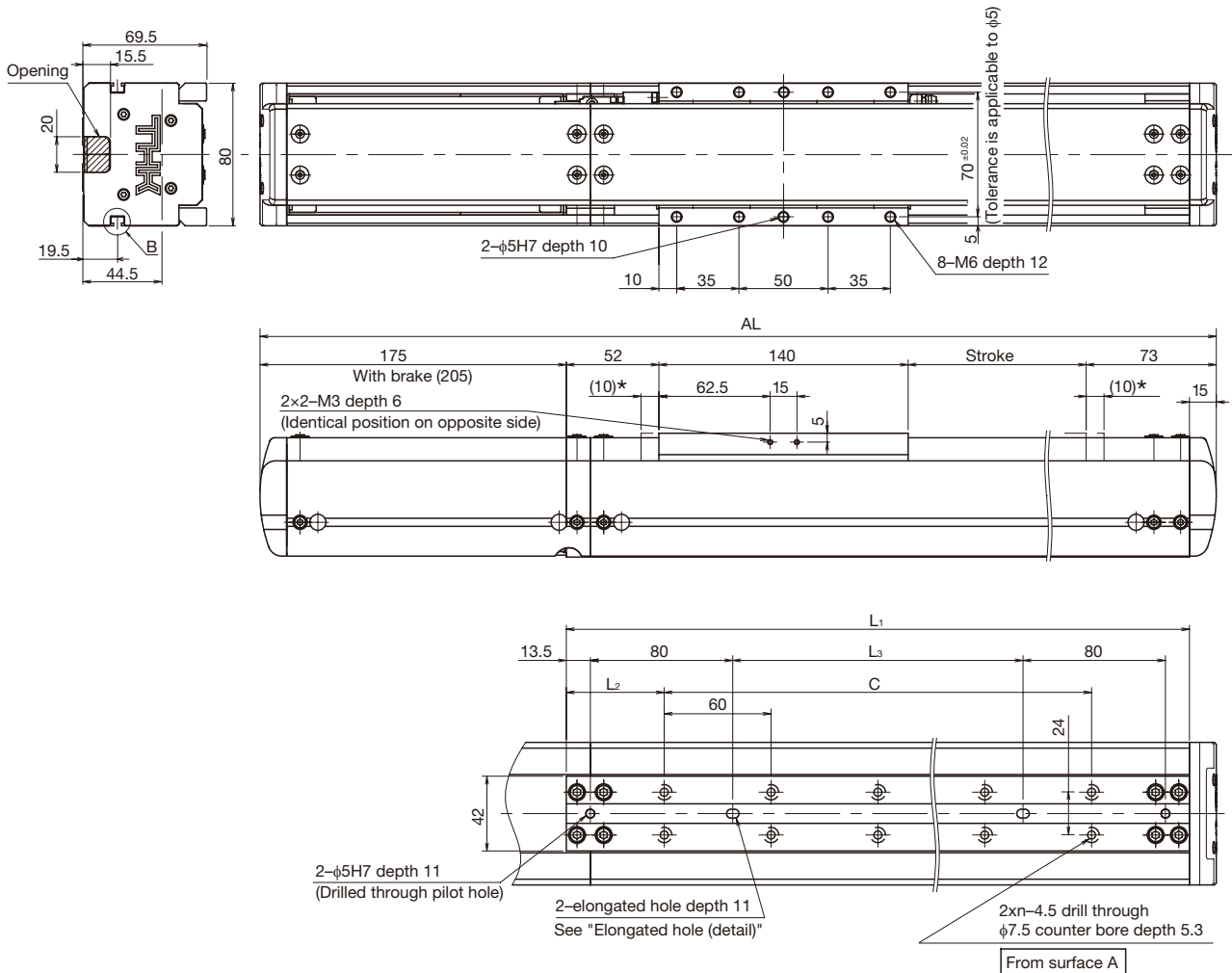

\* Stroke up to mechanical stopper.

Stroke [mm] (Stroke between mechanical stoppers)		100 (120)	150 (170)	200 (220)	250 (270)	300 (320)	350 (370)	400 (420)	450 (470)	500 (520)	
Maximum speed * <sup>1</sup> * <sup>2</sup> [mm/s]	Ball screw lead	5mm				300					
		10mm				600					
		20mm					1200				
		30mm					1800				
Dimensions [mm]	AL <sup>*3</sup>	540 (570)	590 (620)	640 (670)	690 (720)	740 (770)	790 (820)	840 (870)	890 (920)	940 (970)	
	L <sub>1</sub>	350	400	450	500	550	600	650	700	750	
	L <sub>2</sub>	55	50	45	40	35	60	55	50	45	
	L <sub>3</sub>	163	213	263	313	363	413	463	513	563	
Mounting hole count	n	5	6	7	8	9	9	10	11	12	
Weight [kg]		5.6	5.8	6.1	6.4	6.7	7	7.3	7.6	7.8	

\*<sup>1</sup> Load capacity and maximum speed vary.

\*<sup>2</sup> The maximum speed is the value restricted by the permissible rotational speed of the ball screw.

\*<sup>3</sup> Values when a brake is installed are shown in parentheses.

# US8T

## Detail

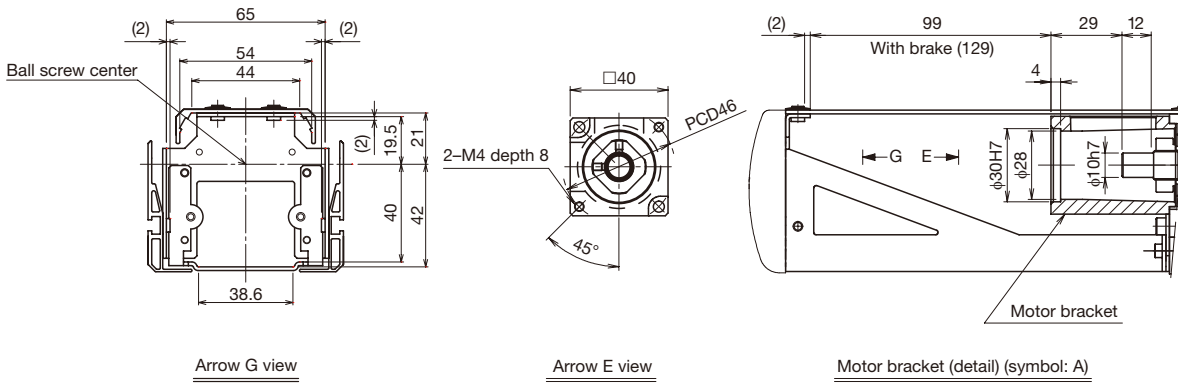

Arrow G view

Arrow E view

Motor bracket (detail) (symbol: A)

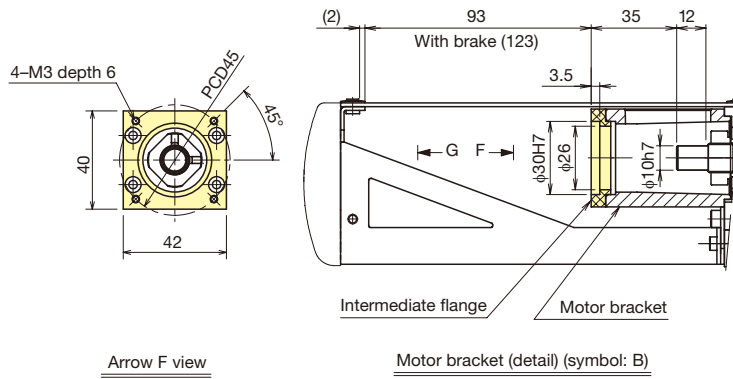

Arrow F view

Motor bracket (detail) (symbol: B)

See page 48, "Motor Brackets," for a list of applicable motors.

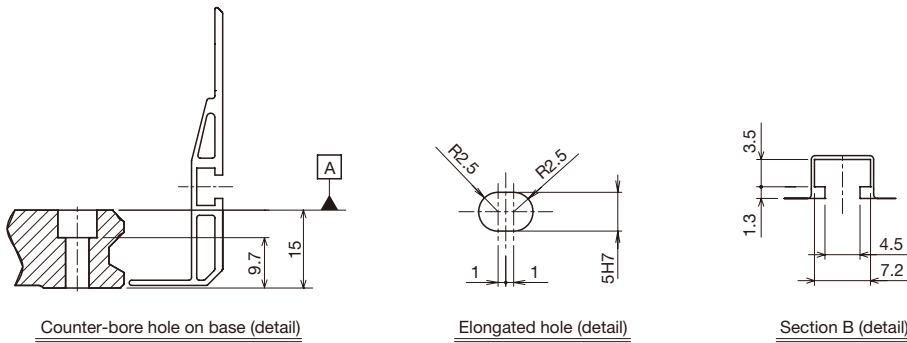

Counter-bore hole on base (detail)

Elongated hole (detail)

Section B (detail)

	550 (570)	600 (620)	650 (670)	700 (720)	750 (770)	800 (820)	850 (870)	900 (920)	950 (970)	1000 (1020)	1050 (1070)	1100 (1120)
		300		290	250	220	200	180	160	150	130	120
		600		550	480	430	380	340	310	280	250	230
		1200		1090	960	850	760	680	610	560	510	460
		1800		1600	1410	1250	1120	1000	910	820	750	690
	990 (1020)	1040 (1070)	1090 (1120)	1140 (1170)	1190 (1220)	1240 (1270)	1290 (1320)	1340 (1370)	1390 (1420)	1440 (1470)	1490 (1520)	1540 (1570)
	800	850	900	950	1000	1050	1100	1150	1200	1250	1300	1350
	40	35	60	55	50	45	40	35	60	55	50	45
	613	663	713	763	813	863	913	963	1013	1063	1113	1163
	720	780	780	840	900	960	1020	1080	1080	1140	1200	1260
	13	14	14	15	16	17	18	19	19	20	21	22
	8.1	8.4	8.6	8.9	9.1	9.4	9.6	9.9	10.2	10.4	10.7	10.9

# US8RT Motor wrap



## Model Configuration

Model	Ball screw lead	Stroke	Design symbol	With/without motor	Sensor	Sensor mounting position
US8RT	05	0150	A	0	6	SL

US8RT	05: 5mm	0100: 100mm	A	0 : Without motor	P	No symbol: When selecting P, Q, or N
	10: 10mm	to		0B: Without motor (With brake)	Q	
	20: 20mm	1100: 1100mm	1 : With motor (Prepared by THK)	N	SL	
	30: 30mm		1B: With motor (Prepared by THK, with brake)	6		
				E		
				J		
				M		

## Reference Basic Specifications

Motor rated output [W]				100				150					
Ball screw lead [mm]				5	10	20	30	10	20	30			
Rated speed * <sup>1</sup> [mm/s]				250	500	1000	1500	500	1000	1500			
Maximum load capacity [kg]	Acceleration and deceleration rate	Horizontal mount	0.3G	80	40	20	8	60	30	12			
		Vertical mount	0.3G	16* <sup>3</sup>	8	4	2	12	6	3			
Rated thrust * <sup>4</sup> [N]				322	161	80	54	240	120	80			
Maximum thrust * <sup>5</sup> [N]				955	478	239	159	719	359	240			
Electromagnetic brake retention [N]				322	161	80	54	161	80	54			
Running life * <sup>6</sup> [km]				10,000									
Static permissible moment * <sup>7</sup> [N·m]				M <sub>A</sub> : 287, M <sub>B</sub> : 235, M <sub>C</sub> : 226									
Positioning repeatability [mm]				±0.020									
Backlash [mm]				0.05									

Static permissible moment

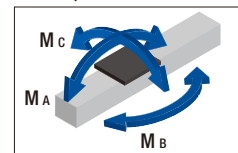

\*<sup>1</sup> At rated motor speed (3,000 min<sup>-1</sup>).

\*<sup>2</sup> Load capacity and maximum speed are dependent on usage conditions.

\*<sup>3</sup> When acceleration and deceleration rate is 0.2G.

\*<sup>4</sup> At rated motor torque.

\*<sup>5</sup> Dependent on maximum peak torque and permissible load.

\*<sup>6</sup> Conditions:

Stroke: 100mm

Acceleration and deceleration rate: 0.3G (ball screw lead 5mm, 0.2G vertical only)

Maximum speed: maximum speed or top speed for stroke length and acceleration and deceleration rate

Applied load: maximum load capacity

Center of gravity: center of top surface of table.

\*<sup>7</sup> Static maximum permissible moment when unit is stationary. Moment standards: M<sub>A</sub> and M<sub>C</sub>: top of table; M<sub>B</sub>: center of table.

# US8RT

Base mounting method	Motor bracket	Option
C	A	MR-GR

C: From top of base (counter-base holes)

A
B

MR : Motor right wrap
ML : Motor left wrap
GR : Gray end cap

Note: If the GR is not included in the model configuration, cover will be red.

## Reference Permissible Overhang Length\*

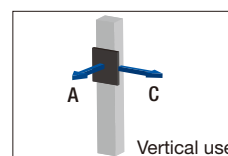
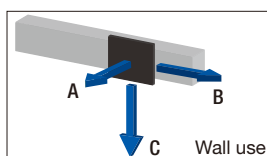
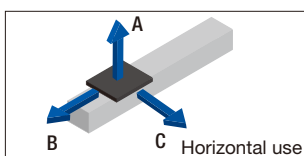

Horizontal mount [mm]

Ball screw lead [mm]	Load mass [kg]	A	B	C
5	20	1610	370	340
	40	970	190	170
	80	520	80	70
10	20	1190	370	310
	40	680	190	150
	60	340	120	100
20	10	1860	660	560
	20	1190	370	310
	30	870	190	210
30	4	2000	1220	1070
	8	2000	780	670
	12	1670	570	490

Wall mount [mm]

Ball screw lead [mm]	Load mass [kg]	A	B	C
5	20	280	310	1410
	40	120	120	750
	80	20	20	250
10	20	280	310	1010
	40	120	120	510
	60	50	60	290
20	10	550	590	1690
	20	280	310	1010
	30	170	190	700
30	4	1080	1150	2000
	8	660	710	1940
	12	470	510	1490

Vertical mount [mm]

Ball screw lead [mm]	Load mass [kg]	A	C
5	4	1190	1180
	8	760	750
	16	440	430
10	4	1150	1140
	8	720	720
	12	530	520
20	2	1690	1680
	4	1150	1140
	6	890	880
30	1	2000	2000
	2	1690	1680
	3	1360	1350

\*Dependent on running life of LM guide (10,000km) and on static permissible moment.

The conditions for calculation are as follows:

Stroke: 100mm

Acceleration and deceleration rate: 0.3G

Maximum speed: maximum speed or top speed for stroke length and acceleration and deceleration rate

Applied load: maximum load capacity.

A, B, and C represent distances measured from the center of the top surface of the table.

# US8RT Motor wrap



## Dimensions

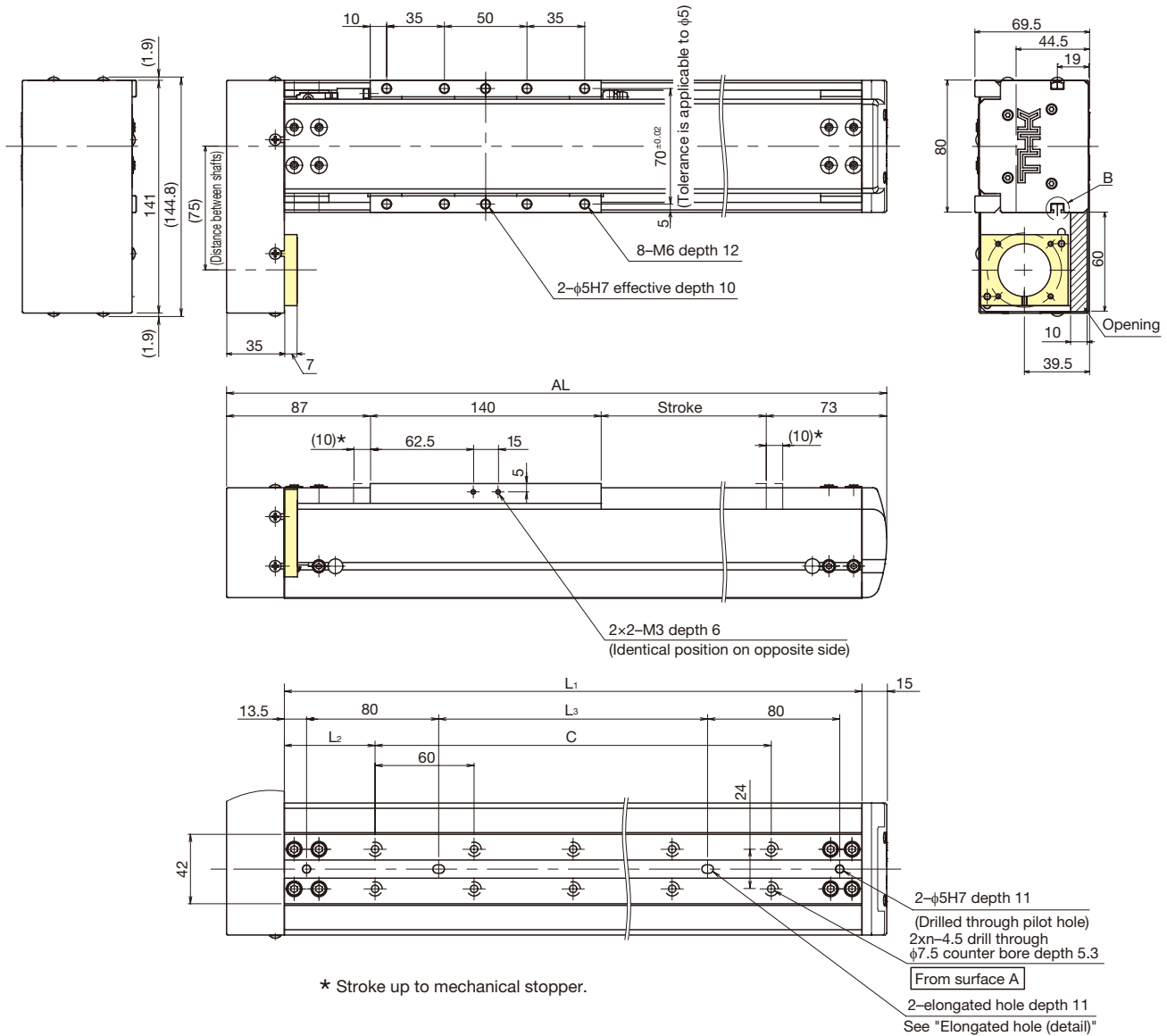

Stroke [mm] (Stroke between mechanical stoppers)		100 (120)	150 (170)	200 (220)	250 (270)	300 (320)	350 (370)	400 (420)	450 (470)	500 (520)
Maximum speed *1 *2 [mm/s]	Ball screw lead	5mm				300				
		10mm				600				
		20mm				1200				
		30mm				1800				
Dimensions [mm]	AL	400	450	500	550	600	650	700	750	800
	L <sub>1</sub>	350	400	450	500	550	600	650	700	750
	L <sub>2</sub>	55	50	45	40	35	60	55	50	45
	L <sub>3</sub>	163	213	263	313	363	413	463	513	563
Mounting hole count	n	5	6	7	8	9	9	10	11	12
Weight [kg]		5.8	6	6.3	6.6	6.9	7.2	7.5	7.7	8

\*1 Load capacity and maximum speed vary.

\*2 The maximum speed is the value restricted by the permissible rotational speed of the ball screw.

# US8RT

## Detail

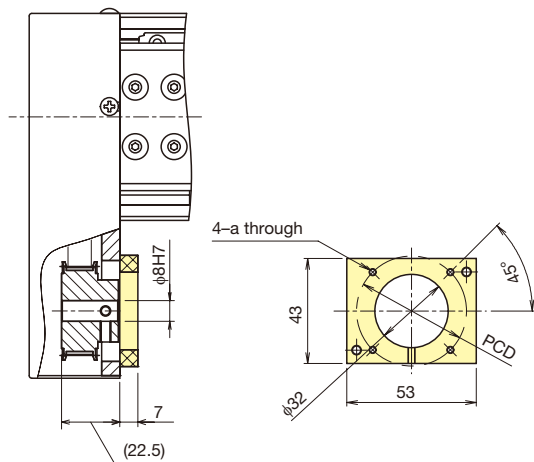

Motor bracket (detail) (symbol: A, B)

Motor bracket specifications [mm]

Symbol	a	PCD
A	M4	46
B	M3	45

See page 48, "Motor Brackets," for a list of applicable motors.

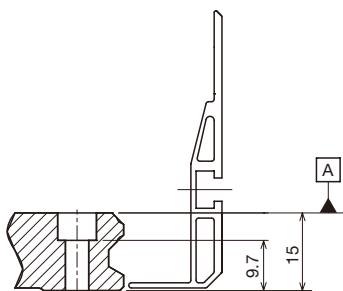

Counter-bore hole on base (detail)

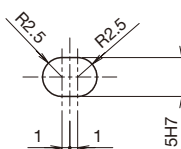

Elongated hole (detail)

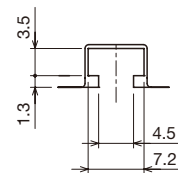

Section B (detail)

	550 (570)	600 (620)	650 (670)	700 (720)	750 (770)	800 (820)	850 (870)	900 (920)	950 (970)	1000 (1020)	1050 (1070)	1100 (1120)
		300		290	250	220	200	180	160	150	130	120
		600		550	480	430	380	340	310	280	250	230
		1200		1090	960	850	760	680	610	560	510	460
		1800		1600	1410	1250	1120	1000	910	820	750	690
	850	900	950	1000	1050	1100	1150	1200	1250	1300	1350	1400
	800	850	900	950	1000	1050	1100	1150	1200	1250	1300	1350
	40	35	60	55	50	45	40	35	60	55	50	45
	613	663	713	763	813	863	913	963	1013	1063	1113	1163
	720	780	780	840	900	960	1020	1080	1080	1140	1200	1260
	13	14	14	15	16	17	18	19	19	20	21	22
	8.3	8.6	8.8	9.1	9.3	9.6	9.8	10.1	10.4	10.6	10.9	11.1

# USW12T Motor coupling

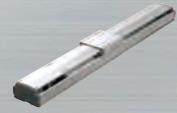

## Model Configuration

Model	Ball screw lead	Stroke	Design symbol	With/without motor	Sensor	Sensor mounting position
USW12T	05	0150	A	0	6	SL

USW12T	05: 5mm	0100: 100mm	A	0 : Without motor	P	No symbol: When selecting P, Q, or N
	10: 10mm	to		0B: Without motor (With brake)	Q	
	20: 20mm	1100: 1100mm	1 : With motor (Prepared by THK)	N	SL	
	30: 30mm		1B: With motor (Prepared by THK, with brake)	6		
				E		
				J		
				M		

## Reference Basic Specifications

Motor rated output [W]	200						
Ball screw lead [mm]	5	10	20	30			
Rated speed <sup>*1</sup> [mm/s]	250	500	1000	1500			
Maximum load capacity <sup>*2</sup> [kg]	Acceleration and deceleration rate	Horizontal mount	0.3G	100	80	40	25
	Vertical mount	0.3G	30	20	8	5	
Rated thrust <sup>*3</sup> [N]	643	322	161	107			
Maximum thrust <sup>*4</sup> [N]	1910	965	482	322			
Electromagnetic brake retention [N]	1277	638	319	213			
Running life <sup>*5 *6</sup> [km]	20,000 (10,000)						
Static permissible moment <sup>*7</sup> [N·m]	M <sub>A</sub> : 915, M <sub>B</sub> : 317, M <sub>C</sub> : 786						
Positioning repeatability [mm]	±0.020						
Backlash [mm]	0.05						

Static permissible moment

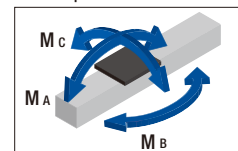

<sup>\*1</sup> At rated motor speed (3,000 min<sup>-1</sup>).

<sup>\*2</sup> Load capacity and maximum speed are dependent on usage conditions.

<sup>\*3</sup> At rated motor torque.

<sup>\*4</sup> Dependent on maximum peak torque and permissible load.

<sup>\*5</sup> Conditions:

Stroke: 100mm

Acceleration and deceleration rate: 0.3G

Maximum speed: maximum speed or top speed for stroke length and acceleration and deceleration rate

Applied load: maximum load capacity

Center of gravity: center of top surface of table.

<sup>\*6</sup> 10,000km with ball screw lead 5mm in vertical use.

<sup>\*7</sup> Static maximum permissible moment when unit is stationary. Moment standards: M<sub>A</sub> and M<sub>C</sub>: top of table; M<sub>B</sub>: center of table.



# USW12T

Base mounting method	Motor bracket	Option
C	A	GR

**T:** From underside of base (tapped holes)  
**C:** From top of base (counter-bore holes)

A
B

**No symbol:** Red end cap  
**GR:** Gray end cap  
**HG:** Hanging jig

Note: If the GR is not included in the model configuration, cover will be red.

## Reference Permissible Overhang Length\*

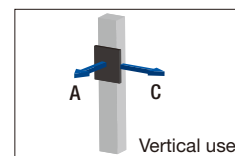
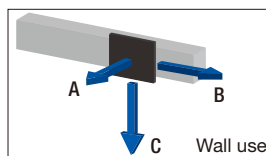
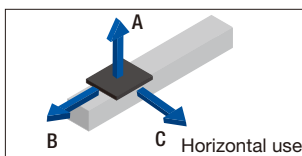

Horizontal mount [mm]

Ball screw lead [mm]	Load mass [kg]	A	B	C
5	30	1870	450	570
	60	1120	230	290
	100	710	130	170
10	20	1790	630	710
	40	1090	340	390
	80	580	160	190
20	10	2000	1060	1170
	20	1790	630	710
	40	1090	340	370
30	5	2000	1620	1770
	15	2000	790	880
	25	1540	520	590

Wall mount [mm]

Ball screw lead [mm]	Load mass [kg]	A	B	C
5	30	530	420	1800
	60	260	200	1030
	100	130	90	600
10	20	710	600	1750
	40	370	310	1020
	80	160	130	500
20	10	1180	1030	2000
	20	710	600	1750
	40	370	310	1050
30	5	1800	1600	2000
	15	890	770	2000
	25	580	500	1490

Vertical mount [mm]

Ball screw lead [mm]	Load mass [kg]	A	C
5	10	1020	1050
	20	600	620
	30	420	430
10	5	1520	1550
	10	980	1000
	20	570	590
20	2	2000	2000
	4	1720	1760
	8	1140	1170
30	1	2000	2000
	3	2000	2000
	5	1520	1550

\*Dependant on running life of LM guide (20,000km) and on static permissible moment.

The conditions for calculation are as follows:

Stroke: 100mm

Acceleration and deceleration rate: 0.3G

Maximum speed: maximum speed or top speed for stroke length and acceleration and deceleration rate

Applied load: maximum load capacity.

A, B, and C represent distances measured from the center of the top surface of the table.

# USW12T Motor coupling

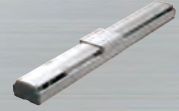

## Dimensions

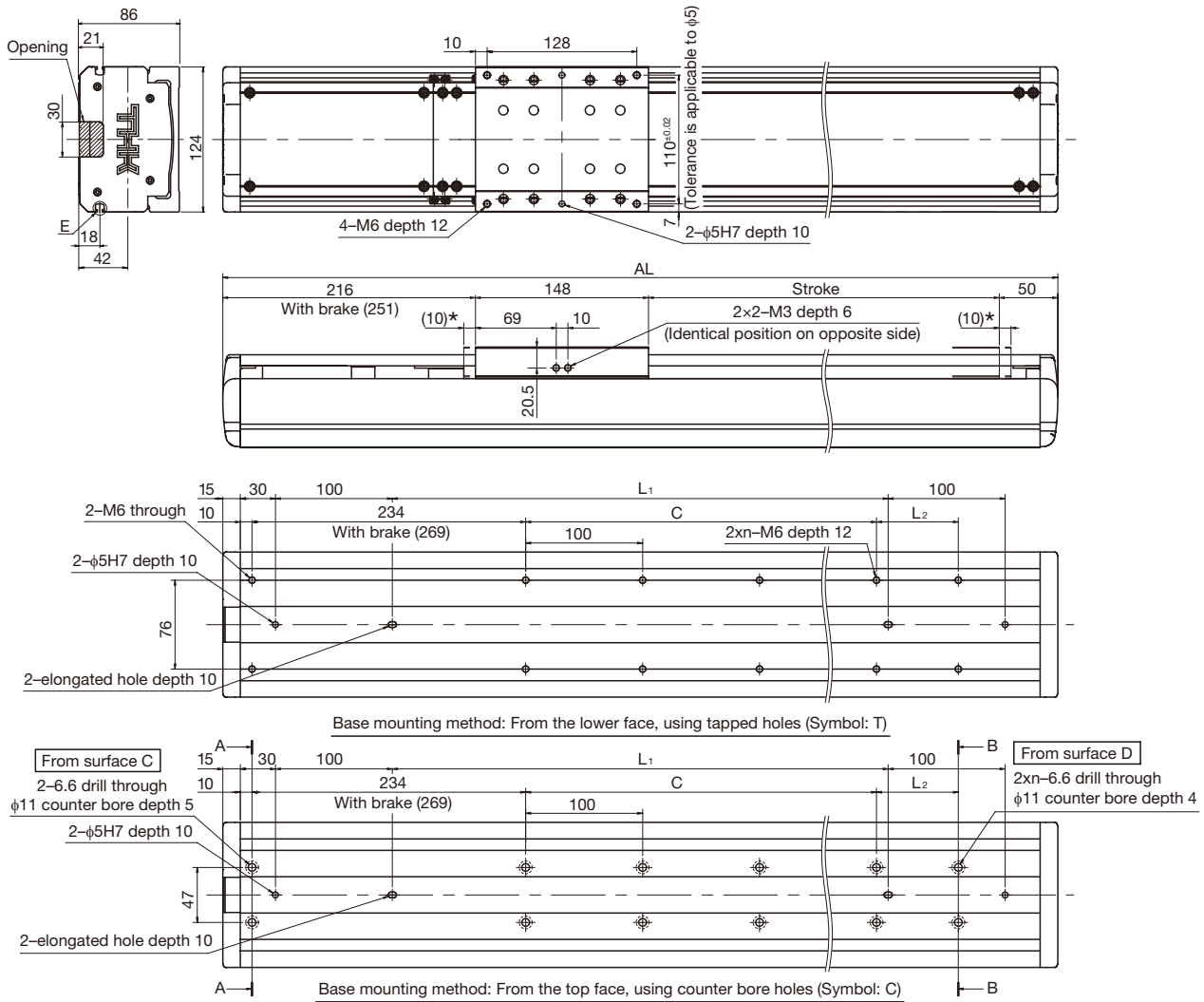

\* Stroke up to mechanical stopper.

Stroke [mm] (Stroke between mechanical stoppers)		100 (120)	150 (170)	200 (220)	250 (270)	300 (320)	350 (370)	400 (420)	450 (470)	500 (520)	
Maximum speed * <sub>1</sub> * <sub>2</sub> [mm/s]	Ball screw lead	5mm	300								
		10mm	600								
		20mm	1200								
		30mm	1800								
Dimensions [mm]	AL * <sub>3</sub>	514 (549)	564 (599)	614 (649)	664 (699)	714 (749)	764 (799)	814 (849)	864 (899)	914 (949)	
	L <sub>1</sub> * <sub>3</sub>	224 (259)	274 (309)	324 (359)	374 (409)	424 (459)	474 (509)	524 (559)	574 (609)	624 (659)	
	L <sub>2</sub>	70	20	70	20	70	20	70	20	70	
	C	100	200	200	300	300	400	400	500	500	
Mounting hole count	n	3	4	4	5	5	6	6	7	7	
Weight [kg]		6.6 (6.9)	7.2 (7.5)	7.8 (8.1)	8.4 (8.7)	9 (9.3)	9.6 (9.9)	10.2 (10.5)	10.8 (11.1)	11.3 (11.6)	

\*<sub>1</sub> Load capacity and maximum speed vary.

\*<sub>2</sub> The maximum speed is the value restricted by the permissible rotational speed of the ball screw.

\*<sub>3</sub> Values when a brake is installed are shown in parentheses.

# USW12T

## Detail

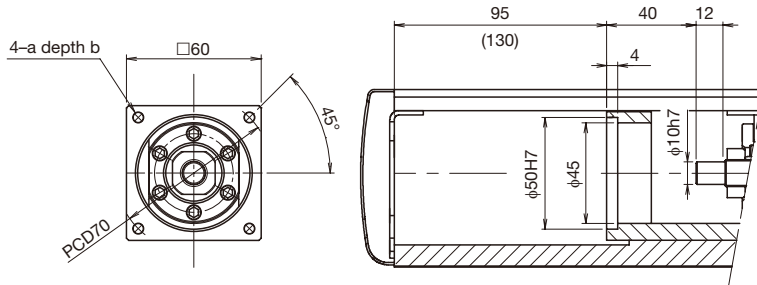

Motor bracket (detail) (symbol: A, B)

Motor bracket specifications [mm]

Symbol	a	b
A	M5	10
B	M4	8

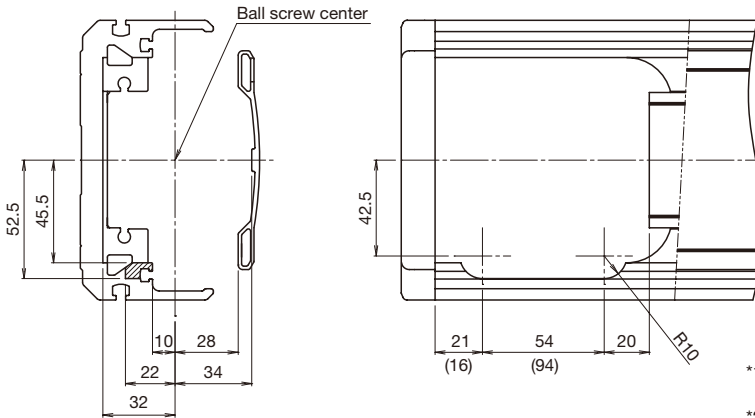

Detailed Diagram: Motor Mounting Part

\*1 Values when a brake is installed are shown in parentheses.

\*2 See page 48, "Motor Brackets," for a list of applicable motors.

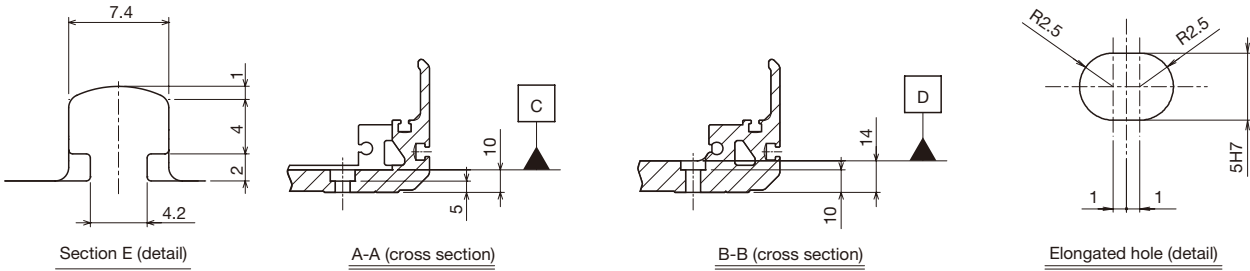

Counter-bore hole in base (detail)

	550 (570)	600 (620)	650 (670)	700 (720)	750 (770)	800 (820)	850 (870)	900 (920)	950 (970)	1000 (1020)	1050 (1070)	1100 (1120)
	300			270	240	210	190	170	150	140	130	120
	600		580	510	450	400	360	320	290	260	240	220
	1200		1160	1020	900	800	720	640	580	530	480	440
	1800		1700	1490	1320	1180	1050	950	860	780	720	660
	964 (999)	1014 (1049)	1064 (1099)	1114 (1149)	1164 (1199)	1214 (1249)	1264 (1299)	1314 (1349)	1364 (1399)	1414 (1449)	1464 (1499)	1514 (1549)
	674 (709)	724 (759)	774 (809)	824 (859)	874 (909)	924 (959)	974 (1009)	1024 (1059)	1074 (1109)	1124 (1159)	1174 (1209)	1224 (1259)
	20	70	20	70	20	70	20	70	20	70	20	70
	600	600	700	700	800	800	900	900	1000	1000	1100	1100
	8	8	9	9	10	10	11	11	12	12	13	13
	12 (12.3)	12.5 (12.8)	13.2 (13.5)	13.7 (14)	14.4 (14.7)	14.9 (15.2)	15.6 (15.9)	16.2 (16.5)	16.8 (17.1)	17.4 (17.7)	18 (18.3)	18.6 (18.9)

# USW12RT Motor wrap



## Model Configuration

Model	Ball screw lead	Stroke	Design symbol	With/without motor	Sensor	Sensor mounting position
USW12RT	05	0150	A	0	6	SL

USW12RT	05: 5mm	0100: 100mm	A	0 : Without motor	P	No symbol: When selecting P, Q, or N
	10: 10mm	to		0B : Without motor (With brake)	Q	
	20: 20mm	1100: 1100mm	1 : With motor (Prepared by THK)	N	SL	
	30: 30mm		1B : With motor (Prepared by THK, with brake)	6		
				E		
				J		
				M		

## Reference Basic Specifications

Motor rated output [W]	200						
Ball screw lead [mm]	5	10	20	30			
Rated speed <sup>*1</sup> [mm/s]	250	500	1000	1500			
Maximum load capacity <sup>*2</sup> [kg]	Acceleration and deceleration rate	Horizontal mount	0.3G	100	80	40	25
	Vertical mount	0.3G	30	20	8	5	
Rated thrust <sup>*3</sup> [N]	643	322	161	107			
Maximum thrust <sup>*4</sup> [N]	1910	965	482	322			
Electromagnetic brake retention [N]	1277	638	319	213			
Running life <sup>*5 *6</sup> [km]	20,000 (10,000)						
Static permissible moment <sup>*7</sup> [N·m]	M <sub>A</sub> : 915, M <sub>B</sub> : 317, M <sub>C</sub> : 786						
Positioning repeatability [mm]	±0.020						
Backlash [mm]	0.05						

Static permissible moment

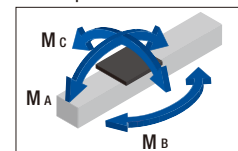

<sup>\*1</sup> At rated motor speed (3,000 min<sup>-1</sup>).

<sup>\*2</sup> Load capacity and maximum speed are dependent on usage conditions.

<sup>\*3</sup> At rated motor torque.

<sup>\*4</sup> Dependent on maximum peak torque and permissible load.

<sup>\*5</sup> Conditions:

Stroke: 100mm

Acceleration and deceleration rate: 0.3G

Maximum speed: maximum speed or top speed for stroke length and acceleration and deceleration rate

Applied load: maximum load capacity

Center of gravity: center of top surface of table.

<sup>\*6</sup> 10,000km with ball screw lead 5mm in vertical use.

<sup>\*7</sup> Static maximum permissible moment when unit is stationary. Moment standards: M<sub>A</sub> and M<sub>C</sub>: top of table; M<sub>B</sub>: center of table.

# USW12RT

Base mounting method	Motor bracket	Option
C	A	MR-GR

T: From underside of base (tapped holes)  
 C: From top of base (counter-bore holes)

A
B
C

MR : Motor right wrap
ML : Motor left wrap
GR : Gray end cap
HG : Hanging jig

Note: If the GR is not included in the model configuration, cover will be red.

## Reference Permissible Overhang Length\*

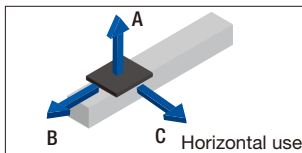

Horizontal mount [mm]

Ball screw lead [mm]	Load mass [kg]	A	B	C
5	30	1870	450	570
	60	1120	230	290
	100	710	130	170
10	20	1790	630	710
	40	1090	340	390
	80	580	160	190
20	10	2000	1060	1170
	20	1790	630	710
	40	1090	340	390
30	5	2000	1620	1770
	15	2000	790	880
	25	1540	520	590

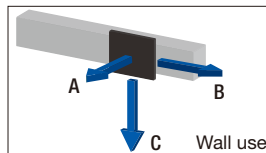

Wall mount [mm]

Ball screw lead [mm]	Load mass [kg]	A	B	C
5	30	530	420	1800
	60	260	200	1030
	100	130	90	600
10	20	710	600	1750
	40	370	310	1020
	80	160	130	500
20	10	1180	1030	2000
	20	710	600	1750
	40	370	310	1020
30	5	1800	1600	2000
	15	890	770	2000
	25	580	500	1490

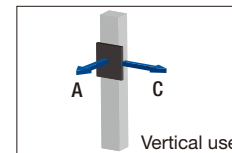

Vertical mount [mm]

Ball screw lead [mm]	Load mass [kg]	A	C
5	10	1020	1050
	20	600	620
	30	420	430
10	5	1520	1550
	10	980	1000
	20	570	590
20	2	2000	2000
	4	1720	1760
	8	1140	1170
30	1	2000	2000
	3	2000	2000
	5	1520	1550

\*Dependant on running life of LM guide (20,000km) and on static permissible moment.

The conditions for calculation are as follows:

Stroke: 100mm

Acceleration and deceleration rate: 0.3G

Maximum speed: maximum speed or top speed for stroke length and acceleration and deceleration rate

Applied load: maximum load capacity.

A, B, and C represent distances measured from the center of the top surface of the table.

# USW12RT Motor wrap



## Dimensions

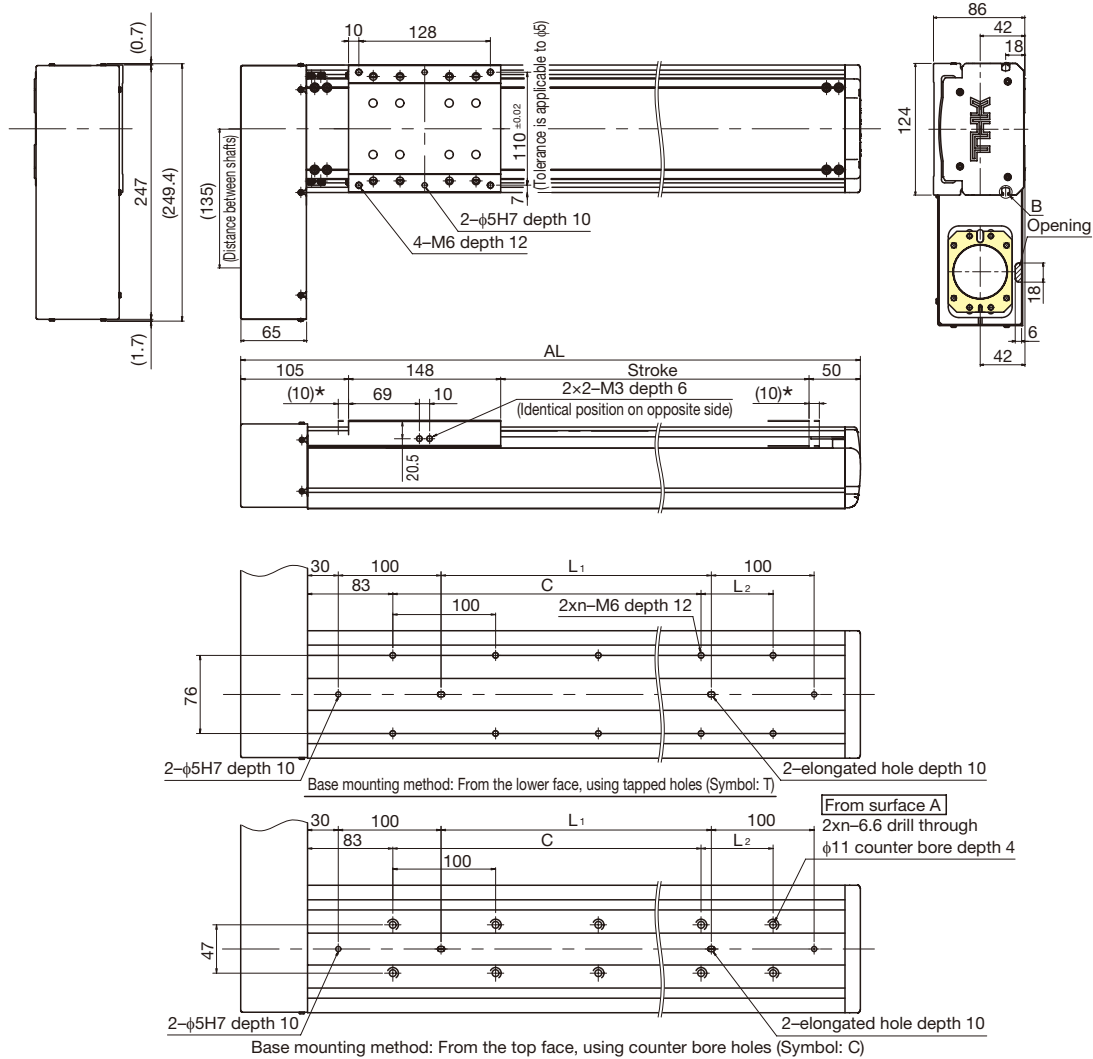

\* Stroke up to mechanical stopper.

Stroke [mm] (Stroke between mechanical stoppers)		100 (120)	150 (170)	200 (220)	250 (270)	300 (320)	350 (370)	400 (420)	450 (470)	500 (520)	
Maximum speed *1 *2 [mm/s]	Ball screw lead										
	5mm	300									
	10mm	600									
	20mm	1200									
	30mm	1800									
Dimensions [mm]	AL	403	453	503	553	603	653	703	753	803	
	L <sub>1</sub>	63	113	163	213	263	313	363	413	463	
	L <sub>2</sub>	70	20	70	20	70	20	70	20	70	
	C	100	200	200	300	300	400	400	500	500	
Mounting hole count	n	3	4	4	5	5	6	6	7	7	
Weight [kg]		8	8.6	9.2	9.8	10.4	11	11.6	12.2	12.8	

\*1 Load capacity and maximum speed vary.

\*2 The maximum speed is the value restricted by the permissible rotational speed of the ball screw.

# USW12RT

## Detail

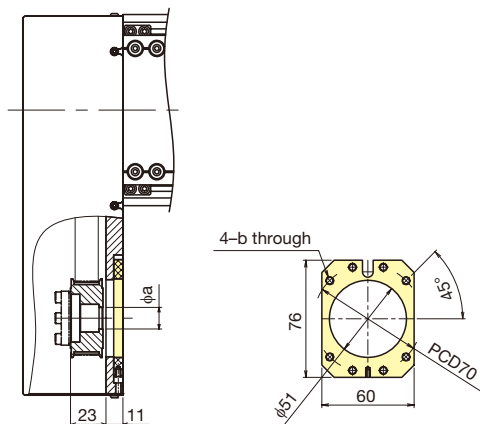

Motor bracket (detail) (symbol: A, B, C)

Motor bracket specifications [mm]

Symbol	a	b
A	14H7	M5
B	14H7	M4
C	11H7	M4

See page 48, "Motor Brackets," for a list of applicable motors.

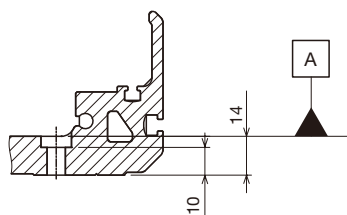

Counter-bore hole on base (detail)

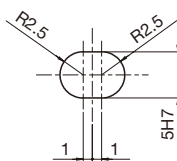

Elongated hole (detail)

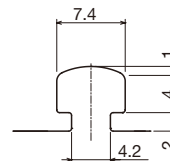

Section B (detail)

	550 (570)	600 (620)	650 (670)	700 (720)	750 (770)	800 (820)	850 (870)	900 (920)	950 (970)	1000 (1020)	1050 (1070)	1100 (1120)
		300		270	240	210	190	170	150	140	130	120
	600		580	510	450	400	360	320	290	260	240	220
	1200		1160	1020	900	800	720	640	580	530	480	440
	1800		1700	1490	1320	1180	1050	950	860	780	720	660
	853	903	953	1003	1053	1103	1153	1203	1253	1303	1353	1403
	513	563	613	663	713	763	813	863	913	963	1013	1063
	20	70	20	70	20	70	20	70	20	70	20	70
	600	600	700	700	800	800	900	900	1000	1000	1100	1100
	8	8	9	9	10	10	11	11	12	12	13	13
	13.4	14	14.6	15.2	15.8	16.4	17	17.6	18.2	18.8	19.4	20

# USW16T Motor coupling

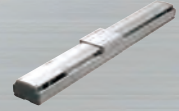

## Model Configuration

Model	Ball screw lead	Stroke	Design symbol	With/without motor	Sensor	Sensor mounting position
USW16T	10	0150	A	0	6	SR

USW16T	10: 10mm	0100: 100mm	A	0 : Without motor	P	No symbol: When selecting P, Q, or N
	20: 20mm	to		0B: Without motor (With brake)	Q	SR
	40: 40mm	1500: 1500mm		1 : With motor (Prepared by THK)	N	SL
				1B: With motor (Prepared by THK, with brake)	6	
					E	
					J	
					M	

## Reference Basic Specifications

Motor rated output [W]	400					
Ball screw lead [mm]	10	20	40			
Rated speed <sup>*1</sup> [mm/s]	500	1000	2000			
Maximum load capacity <sup>*2</sup> [kg]	Acceleration and deceleration rate	Horizontal mount	0.3G	120	80	40
	Vertical mount	0.3G	35	15	9	
Rated thrust <sup>*3</sup> [N]	653	326	163			
Maximum thrust <sup>*4</sup> [N]	1910	965	482			
Electromagnetic brake retention [N]	638	319	160			
Running life <sup>*5</sup> [km]	20,000					
Static permissible moment <sup>*6</sup> [N·m]	M <sub>A</sub> : 2161, M <sub>B</sub> : 740, M <sub>C</sub> : 1681					
Positioning repeatability [mm]	±0.020					
Backlash [mm]	0.05					

Static permissible moment

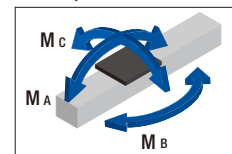

<sup>\*1</sup> At rated motor speed (3,000 min<sup>-1</sup>).

<sup>\*2</sup> Load capacity and maximum speed are dependent on usage conditions.

<sup>\*3</sup> At rated motor torque.

<sup>\*4</sup> Dependent on maximum peak torque and permissible load.

<sup>\*5</sup> Conditions:

Stroke: 100mm

Acceleration and deceleration rate: 0.3G

Maximum speed: maximum speed or top speed for stroke length and acceleration and deceleration rate

Applied load: maximum load capacity

Center of gravity: center of top surface of table.

<sup>\*6</sup> Static maximum permissible moment when unit is stationary. Moment standards: M<sub>A</sub> and M<sub>C</sub>: top of table; M<sub>B</sub>: center of table.



# USW16T

Base mounting method	Motor bracket	Option
C	A	GR

T: From underside of base (tapped holes)
C: From top of base (counter-bore holes)

A
B

No symbol: Red end cap
GR: Gray end cap
HG: Hanging jig

Note: If the GR is not included in the model configuration, cover will be red.

## Reference Permissible Overhang Length\*

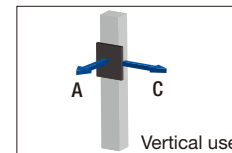
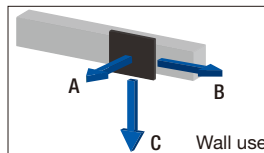
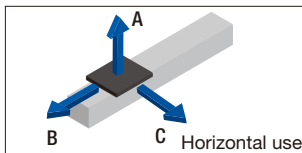

Horizontal mount [mm]

Ball screw lead [mm]	Load mass [kg]	A	B	C
10	40	2590	950	820
	80	1590	520	440
	120	1130	340	290
20	20	3000	1560	1380
	40	2590	950	820
	80	1590	520	440
40	10	3000	2360	2100
	20	3000	1560	1380
	40	2590	950	820

Wall mount [mm]

Ball screw lead [mm]	Load mass [kg]	A	B	C
10	40	760	900	2480
	80	380	460	1450
	120	230	280	970
20	20	1300	1520	3000
	40	760	900	2480
	80	380	460	1450
40	10	2020	2320	3000
	20	1300	1520	3000
	40	760	900	2480

Vertical mount [mm]

Ball screw lead [mm]	Load mass [kg]	A	C
10	10	2220	2270
	20	1460	1500
	35	970	1000
20	5	3000	3000
	10	2220	2270
	15	1750	1800
40	3	3000	3000
	6	2890	2960
	9	2350	2410

\*Dependent on running life of LM guide (20,000km) and on static permissible moment.

The conditions for calculation are as follows:

Stroke: 100mm

Acceleration and deceleration rate: 0.3G

Maximum speed: maximum speed or top speed for stroke length and acceleration and deceleration rate

Applied load: maximum load capacity.

A, B, and C represent distances measured from the center of the top surface of the table.



# USW16T

## Detail

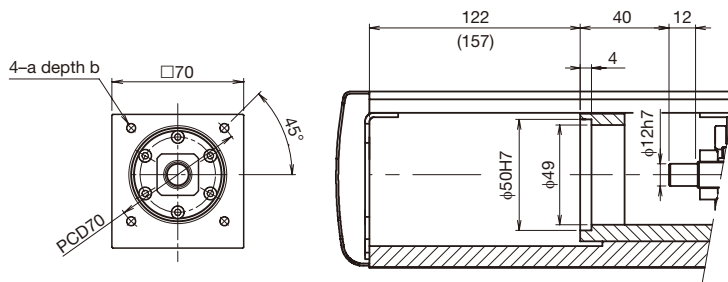

Motor bracket (detail) (symbol: A, B)

Motor bracket specifications [mm]

Symbol	a	b
A	M5	10
B	M4	8

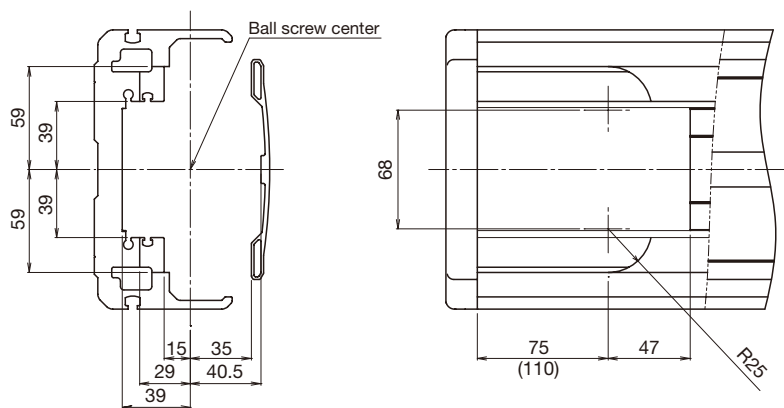

Detailed Diagram: Motor Mounting Part

\*1 Values when a brake is installed are shown in parentheses.

\*2 See page 48, "Motor Brackets," for a list of applicable motors.

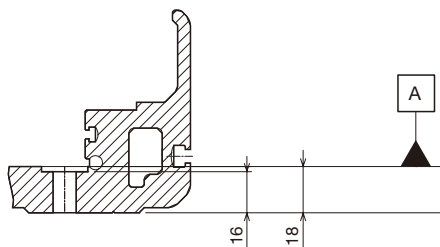

Counter-bore hole on base (detail)

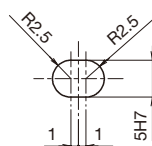

Elongated hole (detail)

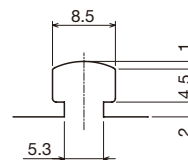

Section B (detail)

	700 (720)	750 (770)	800 (820)	850 (870)	900 (920)	950 (970)	1000 (1020)	1050 (1070)	1100 (1120)	1150 (1170)	1200 (1220)	1250 (1270)	1300 (1320)	1350 (1370)	1400 (1420)	1450 (1470)	1500 (1520)
	550		520	470	420	380	340	310	290	260	240	230	210	190	180	170	160
	1100			1040	930	840	760	700	640	590	540	500	460	430	400	380	350
	2200			1970	1780	1610	1470	1340	1230	1130	1050	970	900	840	780	730	690
	1176 (1211)	1226 (1261)	1276 (1311)	1326 (1361)	1376 (1411)	1426 (1461)	1476 (1511)	1526 (1561)	1576 (1611)	1626 (1661)	1676 (1711)	1726 (1761)	1776 (1811)	1826 (1861)	1876 (1911)	1926 (1961)	1976 (2011)
	880 (915)	930 (965)	980 (1015)	1030 (1065)	1080 (1115)	1130 (1165)	1180 (1215)	1230 (1265)	1280 (1315)	1330 (1365)	1380 (1415)	1430 (1465)	1480 (1515)	1530 (1565)	1580 (1615)	1630 (1665)	1680 (1715)
	50	100	150	-	50	100	150	-	50	100	150	-	50	100	150	-	50
	800	800	800	1000	1000	1000	1000	1200	1200	1200	1200	1400	1400	1400	1400	1600	1600
	7	7	7	7	8	8	8	8	9	9	9	9	10	10	10	10	11
	25.1 (25.5)	26.1 (26.5)	27.1 (27.5)	28.1 (28.5)	29.1 (29.5)	30.1 (30.5)	31.1 (31.5)	32.1 (32.5)	33.1 (33.5)	34.1 (34.5)	35.1 (35.5)	36.1 (36.5)	37.1 (37.5)	38.1 (38.5)	39.1 (39.5)	40.1 (40.5)	41.1 (41.5)

# USW16RT Motor wrap



## Model Configuration

Model	Ball screw lead	Stroke	Design symbol	With/without motor	Sensor	Sensor mounting position
USW16RT	10	0150	A	0	6	SL

USW16RT	10: 10mm	0100: 100mm	A	0 : Without motor	P	No symbol: When selecting P, Q, or N
	20: 20mm	to		0B: Without motor (With brake)	Q	
	40: 40mm	1500: 1500mm	1 : With motor (Prepared by THK)	N	SL	
			1B: With motor (Prepared by THK, with brake)	6		
				E		
				J		
				M		

## Reference Basic Specifications

Motor rated output [W]	400					
Ball screw lead [mm]	10	20	40			
Rated speed * <sup>1</sup> [mm/s]	500	1000	2000			
Maximum load capacity * <sup>2</sup> [kg]	Acceleration and deceleration rate	Horizontal mount	0.3G	120	80	40
	Vertical mount	0.3G	35	15	9	
Rated thrust * <sup>3</sup> [N]	653	326	163			
Maximum thrust * <sup>4</sup> [N]	1910	965	482			
Electromagnetic brake retention [N]	638	319	160			
Running life * <sup>5</sup> [km]	20,000					
Static permissible moment * <sup>6</sup> [N·m]	M <sub>A</sub> : 2161, M <sub>B</sub> : 740, M <sub>C</sub> : 1681					
Positioning repeatability [mm]	±0.020					
Backlash [mm]	0.05					

Static permissible moment

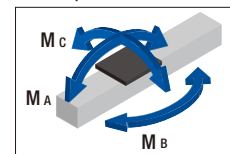

\*<sup>1</sup> At rated motor speed (3,000 min<sup>-1</sup>).

\*<sup>2</sup> Load capacity and maximum speed are dependent on usage conditions.

\*<sup>3</sup> At rated motor torque.

\*<sup>4</sup> Dependent on maximum peak torque and permissible load.

\*<sup>5</sup> Conditions:

Stroke: 100mm

Acceleration and deceleration rate: 0.3G

Maximum speed: maximum speed or top speed for stroke length and acceleration and deceleration rate

Applied load: maximum load capacity

Center of gravity: center of top surface of table.

\*<sup>6</sup> Static maximum permissible moment when unit is stationary. Moment standards: M<sub>A</sub> and M<sub>C</sub>: top of table; M<sub>B</sub>: center of table.

# USW16RT

Base mounting method	Motor bracket	Option
C	A	MR-GR

T: From underside of base (tapped holes)  
 C: From top of base (counter-bore holes)

A  
 B

MR: Motor right wrap  
 ML: Motor left wrap  
 GR: Gray end cap  
 HG: Hanging jig

Note: If the GR is not included in the model configuration, cover will be red.

## Reference Permissible Overhang Length\*

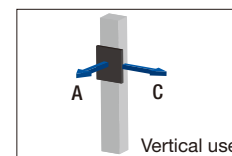
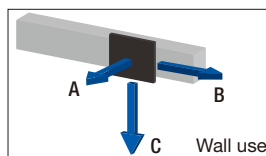
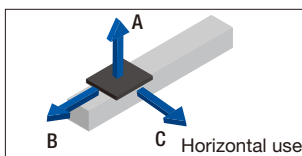

Horizontal mount [mm]

Ball screw lead [mm]	Load mass [kg]	A	B	C
10	40	2590	950	820
	80	1590	520	440
	120	1130	340	290
20	20	3000	1560	1380
	40	2590	950	820
	80	1590	520	440
40	10	3000	2360	2100
	20	3000	1560	1380
	40	2590	950	820

Wall mount [mm]

Ball screw lead [mm]	Load mass [kg]	A	B	C
10	40	760	900	2480
	80	380	460	1450
	120	230	280	970
20	20	1300	1520	3000
	40	760	900	2480
	80	380	460	1450
40	10	2020	2320	3000
	20	1300	1520	3000
	40	760	900	2480

Vertical mount [mm]

Ball screw lead [mm]	Load mass [kg]	A	C
10	10	2220	2270
	20	1460	1500
	35	970	1000
20	5	3000	3000
	10	2220	2270
	15	1750	1800
40	3	3000	3000
	6	2890	2960
	9	2350	2410

\*Dependent on running life of LM guide (20,000km) and on static permissible moment. The conditions for calculation are as follows:

Stroke: 100mm

Acceleration and deceleration rate: 0.3G

Maximum speed: maximum speed or top speed for stroke length and acceleration and deceleration rate

Applied load: maximum load capacity.

A, B, and C represent distances measured from the center of the top surface of the table.

# USW16RT Motor wrap



## Dimensions

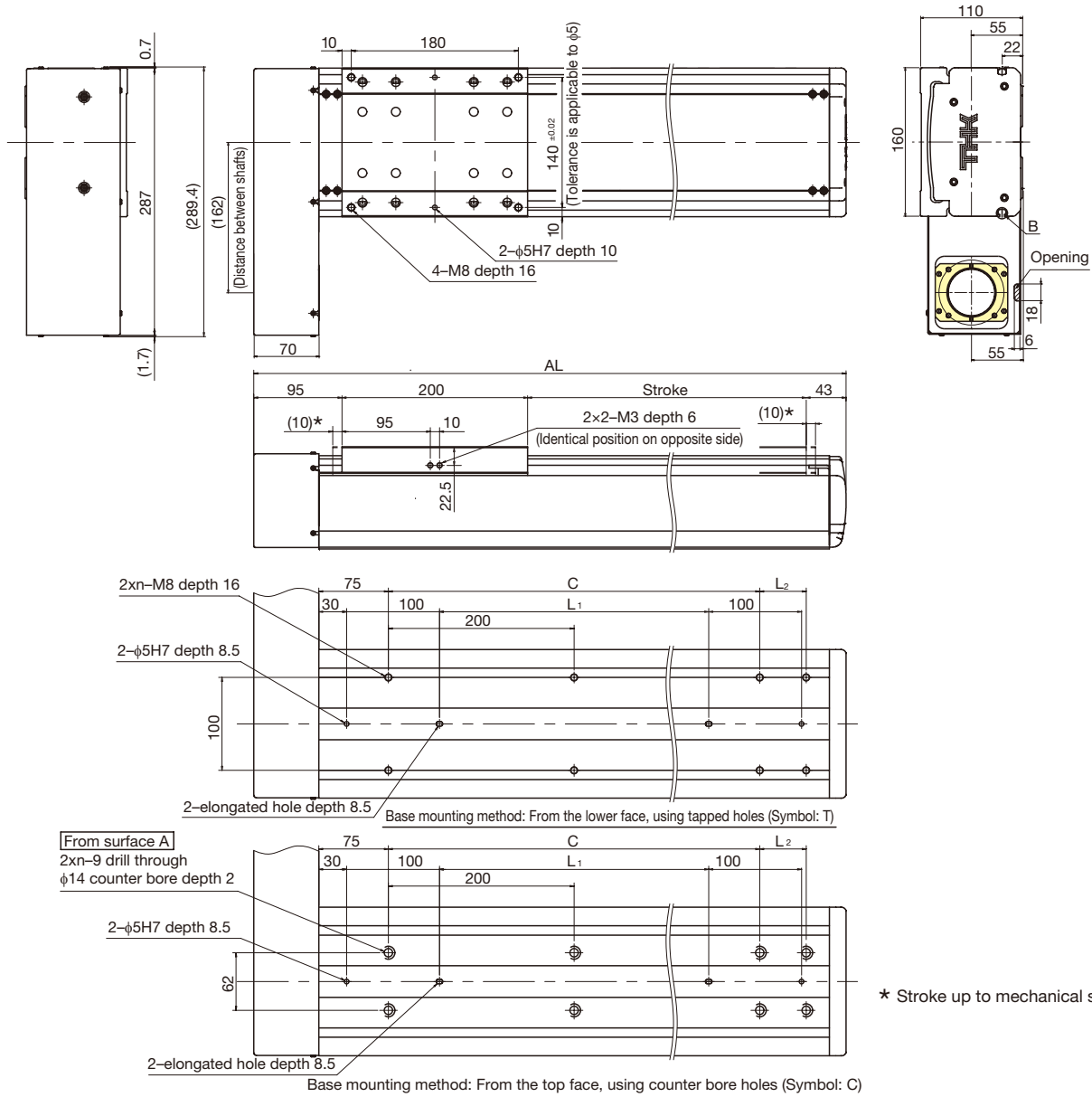

\* Stroke up to mechanical stopper.

Stroke [mm] (Stroke between mechanical stoppers)		100 (120)	150 (170)	200 (220)	250 (270)	300 (320)	350 (370)	400 (420)	450 (470)	500 (520)	550 (570)	600 (620)	650 (670)
Maximum speed *1 *2 [mm/s]	Ball screw lead												
	10mm	550											
	20mm	1100											
Dimensions [mm]	AL	438	488	538	588	638	688	738	788	838	888	938	988
	L <sub>1</sub>	90	140	190	240	290	340	390	440	490	540	590	640
	L <sub>2</sub>	50	100	150	-	50	100	150	-	50	100	150	-
	C	200	200	200	400	400	400	400	600	600	600	600	800
Mounting hole count	n	3	3	3	3	4	4	4	4	5	5	5	5
Weight [kg]		13.4	14.4	15.4	16.4	17.4	18.4	19.4	20.4	21.4	22.4	23.4	24.4

\*1 Load capacity and maximum speed vary.

\*2 The maximum speed is the value restricted by the permissible rotational speed of the ball screw.

# USW16RT

## Detail

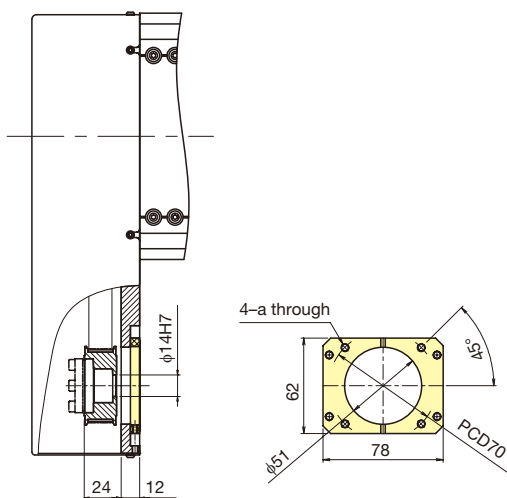

Motor bracket (detail) (symbol: A, B)

Motor bracket specifications

Symbol	a
A	M5
B	M4

See page 48, "Motor Brackets," for a list of applicable motors.

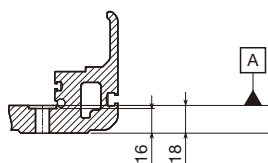

Counter-bore hole on base (detail)

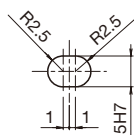

Elongated hole (detail)

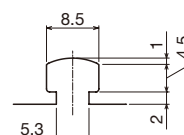

Section B (detail)

	700 (720)	750 (770)	800 (820)	850 (870)	900 (920)	950 (970)	1000 (1020)	1050 (1070)	1100 (1120)	1150 (1170)	1200 (1220)	1250 (1270)	1300 (1320)	1350 (1370)	1400 (1420)	1450 (1470)	1500 (1520)
	550		520	470	420	380	340	310	290	260	240	230	210	190	180	170	160
	1100			1040	930	840	760	700	640	590	540	500	460	430	400	380	350
	2200			1970	1780	1610	1470	1340	1230	1130	1050	970	900	840	780	730	690
	1038	1088	1138	1188	1238	1288	1338	1388	1438	1488	1538	1588	1638	1688	1738	1788	1838
	690	740	790	840	890	940	990	1040	1090	1140	1190	1240	1290	1340	1390	1440	1490
	50	100	150	–	50	100	150	–	50	100	150	–	50	100	150	–	50
	800	800	800	1000	1000	1000	1000	1200	1200	1200	1200	1400	1400	1400	1400	1600	1600
	6	6	6	6	7	7	7	7	8	8	8	8	9	9	9	9	10
	25.4	26.4	27.4	28.4	29.4	30.4	31.4	32.4	33.4	34.4	35.4	36.4	37.4	38.4	39.4	40.4	41.4

# USW20T Motor coupling

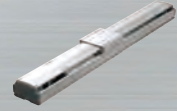

## Model Configuration

Model	Ball screw lead	Stroke	Design symbol	With/without motor	Sensor	Sensor mounting position
USW20T	20	0300	A	0	N	SR

USW20T	20: 20mm	0200: 200mm	A	0 : Without motor	P	No symbol: When selecting P, Q, or N
	40: 40mm	to		0B: Without motor (With brake)	Q	
		1700: 1700mm		1 : With motor (Prepared by THK)	N	SR
				1B: With motor (Prepared by THK, with brake)	6	SL
					E	
					J	
					M	

## Reference Basic Specifications

Motor rated output [W]	750		
Ball screw lead [mm]	20      40		
Rated speed <sup>*1</sup> [mm/s]	1000      2000		
Maximum load capacity <sup>*2</sup> [kg]	Acceleration and deceleration rate	Horizontal mount	0.3G
		Vertical mount	0.3G
Rated thrust <sup>*3</sup> [N]	603      302		
Maximum thrust <sup>*4</sup> [N]	1810      905		
Electromagnetic brake retention [N]	603      302		
Running life <sup>*5 *6</sup> [km]	20,000 (10,000)		
Static permissible moment <sup>*7</sup> [N·m]	M <sub>A</sub> : 1921, M <sub>B</sub> : 793, M <sub>C</sub> : 2221		
Positioning repeatability [mm]	±0.020		
Backlash [mm]	0.05		

Static permissible moment

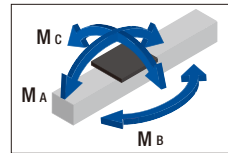

<sup>\*1</sup> At rated motor speed (3,000 min<sup>-1</sup>).

<sup>\*2</sup> Load capacity and maximum speed are dependent on usage conditions.

<sup>\*3</sup> At rated motor torque.

<sup>\*4</sup> Dependent on maximum peak torque and permissible load.

<sup>\*5</sup> Conditions:

Stroke: 200mm

Acceleration and deceleration rate: 0.3G

Maximum speed: maximum speed or top speed for stroke length and acceleration and deceleration rate

Applied load: maximum load capacity

Center of gravity: center of top surface of table.

<sup>\*6</sup> 10,000 km with ball screw lead 20 mm in vertical use.

<sup>\*7</sup> Static maximum permissible moment when unit is stationary. Moment standards: M<sub>A</sub> and M<sub>C</sub>: top of table; M<sub>B</sub>: center of table.



# USW20T

Base mounting method	Motor bracket	Option
C	A	GR

**T:** From underside of base (tapped holes)  
**C:** From top of base (counter-bore holes)

**A**  
**B**

**No symbol:** Red end cap  
**GR:** Gray end cap  
**HG:** Hanging jig

Note: If the GR is not included in the model configuration, cover will be red.

## Reference Permissible Overhang Length\*

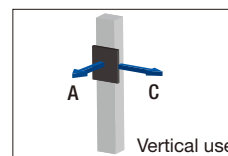
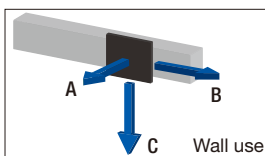
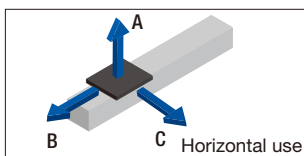

Horizontal mount [mm]

Ball screw lead [mm]	Load mass [kg]	A	B	C
20	40	2640	950	1260
	80	1640	530	720
	130	1100	320	450
40	25	3000	1340	1750
	50	2290	790	1070
	70	1810	590	810

Wall mount [mm]

Ball screw lead [mm]	Load mass [kg]	A	B	C
20	40	1180	920	2630
	80	650	490	1590
	130	390	290	1030
40	25	1660	1320	3000
	50	990	770	2270
	70	740	560	1770

Vertical mount [mm]

Ball screw lead [mm]	Load mass [kg]	A	C
20	15	1700	1770
	30	1060	1100
	45	770	800
40	5	3000	3000
	10	2160	2240
	20	1410	1470

\*Dependent on running life of LM guide (20,000km) and on static permissible moment.

The conditions for calculation are as follows:

Stroke: 200mm

Acceleration and deceleration rate: 0.3G

Maximum speed: maximum speed or top speed for stroke length and acceleration and deceleration rate

Applied load: maximum load capacity.

A, B, and C represent distances measured from the center of the top surface of the table.

# USW20T Motor coupling

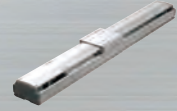

## Dimensions

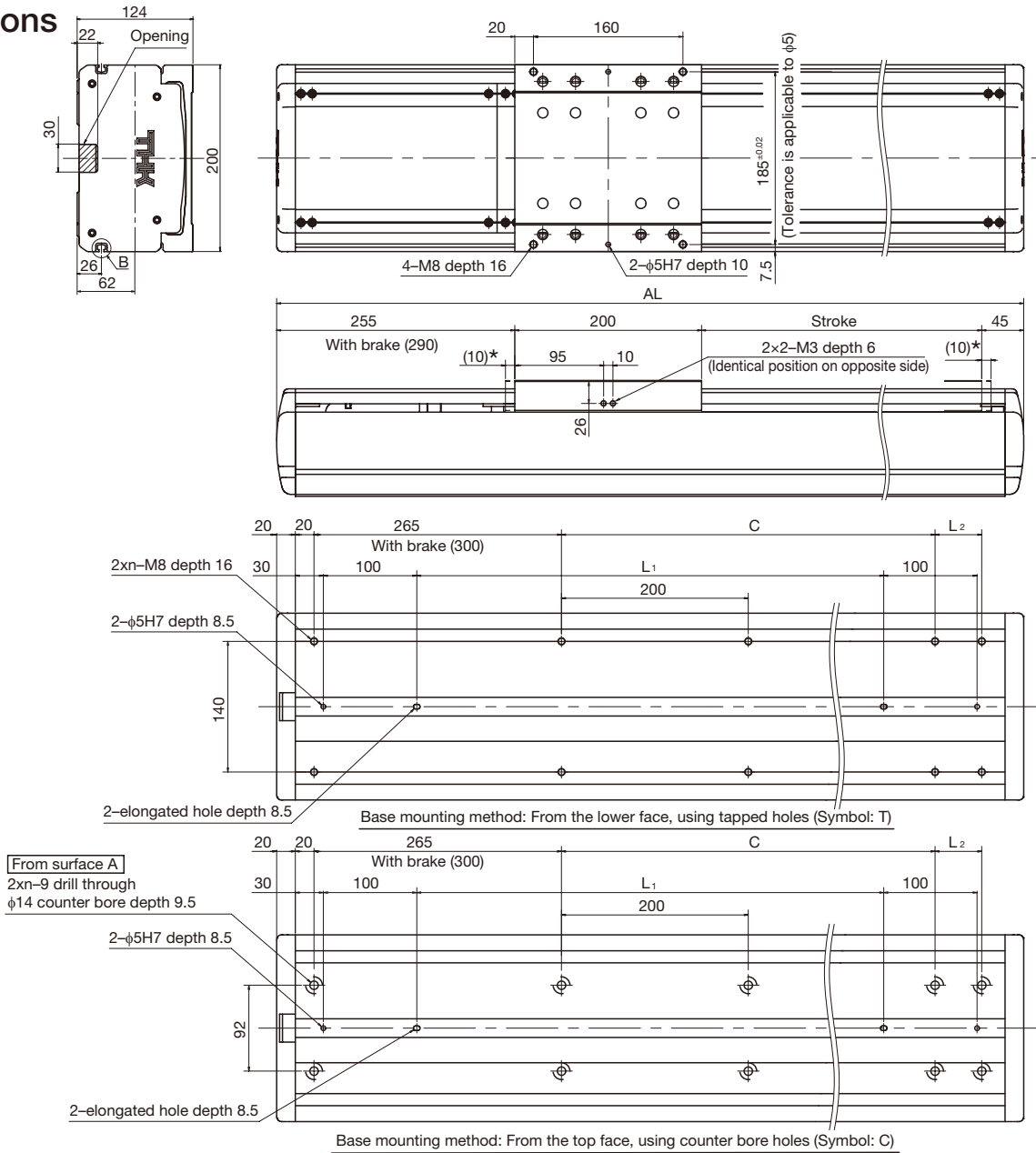

\* Stroke up to mechanical stopper.

Stroke [mm] (Stroke between mechanical stoppers)		200 (220)	250 (270)	300 (320)	350 (370)	400 (420)	450 (470)	500 (520)	550 (570)	600 (620)	650 (670)	700 (720)	750 (770)	800 (820)
Maximum speed *1 *2 [mm/s]	Ball screw lead	1100												
	20mm 40mm	2200												2140
Dimensions [mm]	AL *3	700 (735)	750 (785)	800 (835)	850 (885)	900 (935)	950 (985)	1000 (1035)	1050 (1085)	1100 (1135)	1150 (1185)	1200 (1235)	1250 (1285)	1300 (1335)
	L1 *3	400 (435)	450 (485)	500 (535)	550 (585)	600 (635)	650 (685)	700 (735)	750 (785)	800 (835)	850 (885)	900 (935)	950 (985)	1000 (1035)
	L2	150	-	50	100	150	-	50	100	150	-	50	100	150
	C	200	400	400	400	400	600	600	600	600	800	800	800	800
Mounting hole count	n	4	4	5	5	5	5	6	6	6	6	7	7	7
Weight [kg]	Without motor	22.6 (23.3)	23.9 (24.6)	25.3 (26)	26.7 (27.4)	28.1 (28.8)	29.6 (30.3)	30.9 (31.6)	32.3 (33)	33.7 (34.4)	35.1 (35.8)	36.6 (37.3)	37.9 (38.6)	39.3 (40)

\*1 Load capacity and maximum speed vary.

\*2 The maximum speed is the value restricted by the permissible rotational speed of the ball screw.

\*3 Values when a brake is installed are shown in parentheses.

# USW20T

## Detail

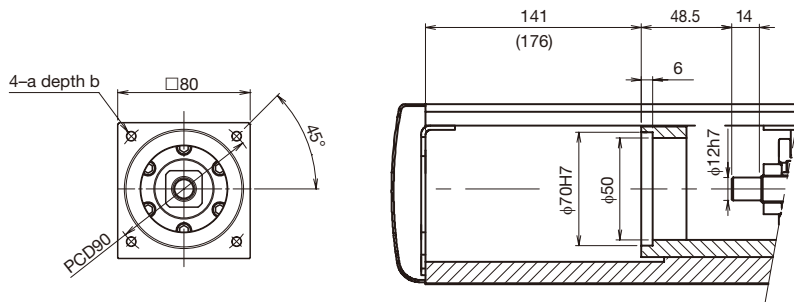

Motor bracket (detail) (symbol: A, B)

Motor bracket specifications [mm]

Symbol	a	b
A	M6	12
B	M5	10

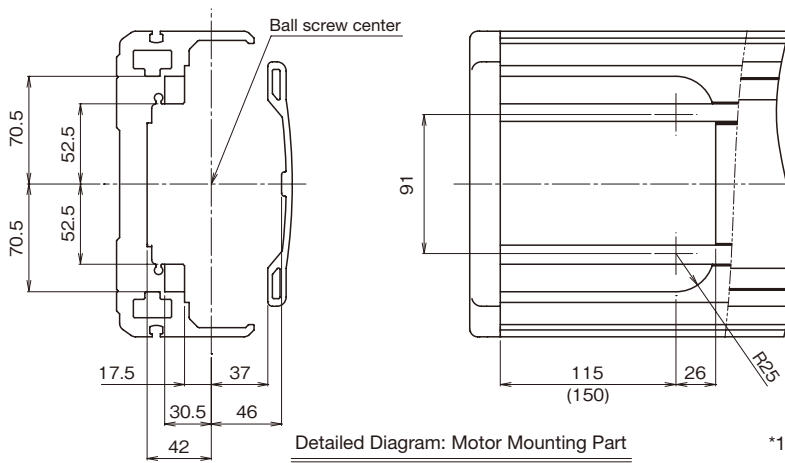

Detailed Diagram: Motor Mounting Part

\*1 Values when a brake is installed are shown in parentheses.

\*2 See page 48, "Motor Brackets," for a list of applicable motors.

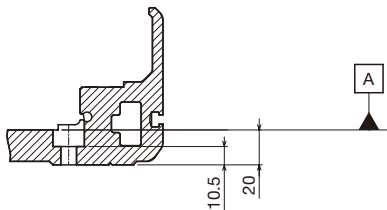

Counter-bore hole on base (detail)

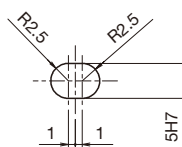

Elongated hole (detail)

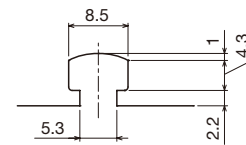

Section B (detail)

	850 (870)	900 (920)	950 (970)	1000 (1020)	1050 (1070)	1100 (1120)	1150 (1170)	1200 (1220)	1250 (1270)	1300 (1320)	1350 (1370)	1400 (1420)	1450 (1470)	1500 (1520)	1550 (1570)	1600 (1620)	1650 (1670)	1700 (1720)
	1010	910	820	750	680	620	570	530	490	460	420	400	370	350	330	310	290	270
	1920	1730	1570	1430	1310	1210	1110	1030	950	890	830	770	720	680	640	600	570	530
	1350 (1385)	1400 (1435)	1450 (1485)	1500 (1535)	1550 (1585)	1600 (1635)	1650 (1685)	1700 (1735)	1750 (1785)	1800 (1835)	1850 (1885)	1900 (1935)	1950 (1985)	2000 (2035)	2050 (2085)	2100 (2135)	2150 (2185)	2200 (2235)
	1050 (1085)	1100 (1135)	1150 (1185)	1200 (1235)	1250 (1285)	1300 (1335)	1350 (1385)	1400 (1435)	1450 (1485)	1500 (1535)	1550 (1585)	1600 (1635)	1650 (1685)	1700 (1735)	1750 (1785)	1800 (1835)	1850 (1885)	1900 (1935)
	-	50	100	150	-	50	100	150	-	50	100	150	-	50	100	150	-	50
	1000	1000	1000	1000	1200	1200	1200	1200	1400	1400	1400	1400	1600	1600	1600	1600	1800	1800
	7	8	8	8	8	9	9	9	9	10	10	10	10	11	11	11	11	12
	40.7 (41.4)	42.1 (42.8)	43.3 (44)	44.9 (45.6)	46.3 (47)	47.7 (48.4)	49.1 (49.8)	50.6 (51.3)	51.9 (52.6)	53.3 (54)	54.7 (55.4)	56.1 (56.8)	57.6 (58.3)	58.9 (59.6)	60.3 (61)	61.7 (62.4)	63.1 (63.8)	64.6 (65.3)

# USW20RT Motor wrap



## Model Configuration

Model	Ball screw lead	Stroke	Design symbol	With/without motor	Sensor	Sensor mounting position
USW20RT	20	0300	A	0	N	SL

  

USW20RT	20: 20mm	0200: 200mm	A	0 : Without motor	P	No symbol: When selecting P, Q, or N
	40: 40mm	to		0B: Without motor (With brake)	Q	SR
		1700: 1700mm		1 : With motor (Prepared by THK)	N	SL
				1B: With motor (Prepared by THK, with brake)	6	
					E	
					J	
					M	

## Reference Basic Specifications

Motor rated output [W]	750		
Ball screw lead [mm]	20	40	
Rated speed <sup>*1</sup> [mm/s]	1000	2000	
Maximum load capacity <sup>*2</sup> [kg]	Acceleration and deceleration rate	Horizontal mount	0.3G
		Vertical mount	0.3G
Rated thrust <sup>*3</sup> [N]	603	302	
Maximum thrust <sup>*4</sup> [N]	1810	905	
Electromagnetic brake retention [N]	603	302	
Running life <sup>*5 *6</sup> [km]	20,000 (10,000)		
Static permissible moment <sup>*7</sup> [N·m]	M <sub>A</sub> : 1921, M <sub>B</sub> : 793, M <sub>C</sub> : 2221		
Positioning repeatability [mm]	±0.020		
Backlash [mm]	0.05		

Static permissible moment

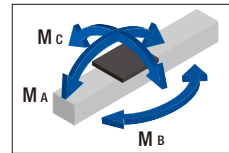

<sup>\*1</sup> At rated motor speed (3,000 min<sup>-1</sup>).

<sup>\*2</sup> Load capacity and maximum speed are dependent on usage conditions.

<sup>\*3</sup> At rated motor torque.

<sup>\*4</sup> Dependent on maximum peak torque and permissible load.

<sup>\*5</sup> Conditions:

Stroke: 200mm

Acceleration and deceleration rate: 0.3G

Maximum speed: maximum speed or top speed for stroke length and acceleration and deceleration rate

Applied load: maximum load capacity

Center of gravity: center of top surface of table.

<sup>\*6</sup> 10,000 km with ball screw lead 20 mm in vertical use.

<sup>\*7</sup> Static maximum permissible moment when unit is stationary. Moment standards: M<sub>A</sub> and M<sub>C</sub>: top of table; M<sub>B</sub>: center of table.

# USW20RT

Base mounting method	Motor bracket	Option
C	A	MR-GR

T: From underside of base (tapped holes)  
 C: From top of base (counter-bore holes)

A
B

MR : Motor right wrap
ML : Motor left wrap
GR : Gray end cap
HG : Hanging jig

Note: If the GR is not included in the model configuration, cover will be red.

## Reference Permissible Overhang Length\*

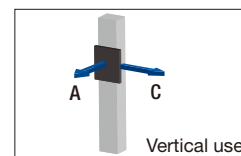
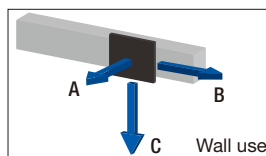
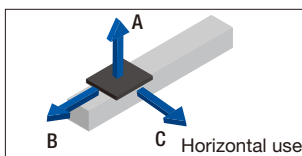

Horizontal mount [mm]

Ball screw lead [mm]	Load mass [kg]	A	B	C
20	40	2640	950	1260
	80	1640	530	720
	130	1100	320	450
40	25	3000	1340	1750
	50	2290	790	1070
	70	1810	590	810

Wall mount [mm]

Ball screw lead [mm]	Load mass [kg]	A	B	C
20	40	1180	920	2630
	80	650	490	1590
	130	390	290	1030
40	25	1660	1320	3000
	50	990	770	2270
	70	740	560	1770

Vertical mount [mm]

Ball screw lead [mm]	Load mass [kg]	A	C
20	15	1700	1770
	30	1060	1100
	45	770	800
40	5	3000	3000
	10	2160	2240
	20	1410	1470

\*Dependent on running life of LM guide (20,000km) and on static permissible moment.

The conditions for calculation are as follows:

Stroke: 200mm

Acceleration and deceleration rate: 0.3G

Maximum speed: maximum speed or top speed for stroke length and acceleration and deceleration rate

Applied load: maximum load capacity.

A, B, and C represent distances measured from the center of the top surface of the table.

# USW20RT Motor wrap



## Dimensions

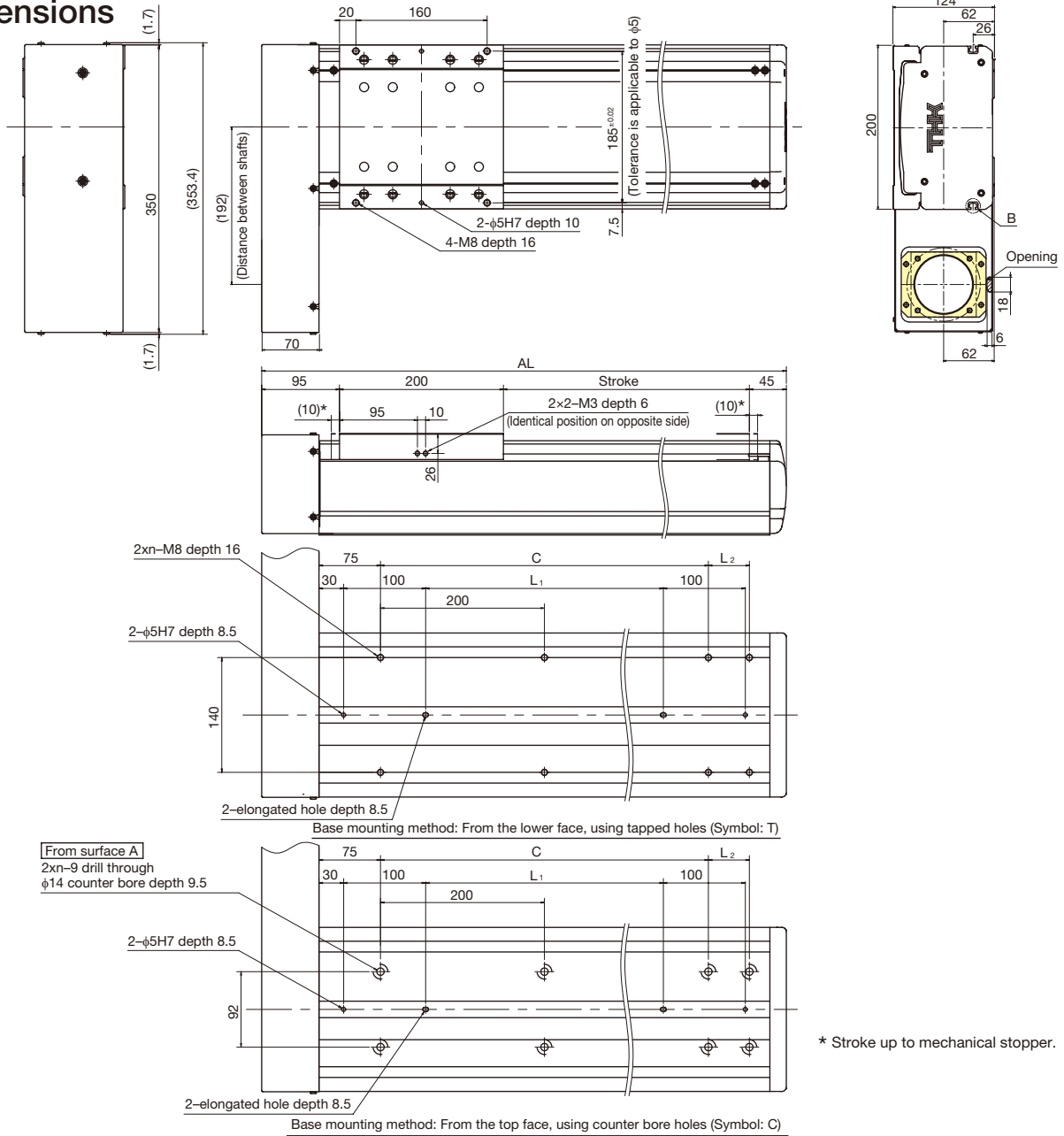

Stroke [mm] (Stroke between mechanical stoppers)		200 (220)	250 (270)	300 (320)	350 (370)	400 (420)	450 (470)	500 (520)	550 (570)	600 (620)	650 (670)	700 (720)	750 (770)	800 (820)
Maximum speed *1 *2 [mm/s]	Ball screw lead	1100												
	20mm	2200												
Dimensions [mm]	AL	540	590	640	690	740	790	840	890	940	990	1040	1090	1140
	L <sub>1</sub>	190	240	290	340	390	440	490	540	590	640	690	740	790
	L <sub>2</sub>	150	-	50	100	150	-	50	100	150	-	50	100	150
	C	200	400	400	400	400	600	600	600	600	800	800	800	800
Mounting hole count	n	3	3	4	4	4	4	5	5	5	5	6	6	6
Weight [kg]		24.8	26.1	27.4	28.8	30.2	31.6	32.9	34.2	35.6	36.9	38.3	39.6	41

\*1 Load capacity and maximum speed vary.

\*2 The maximum speed is the value restricted by the permissible rotational speed of the ball screw.

# USW20RT

## Detail

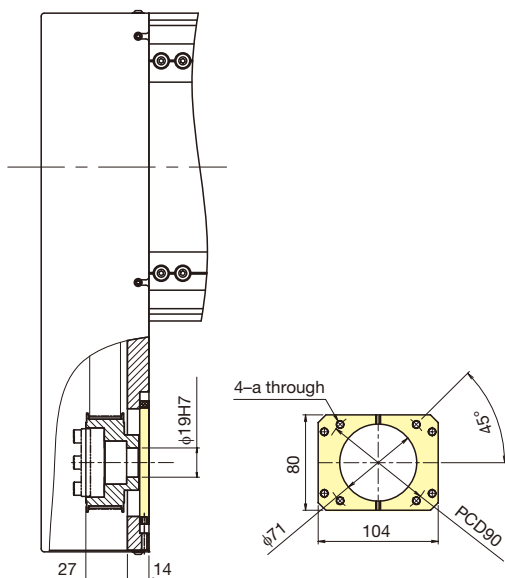

Motor bracket (detail)

Motor bracket specifications

Symbol	a
A	M6
B	M5

See page 48, "Motor Brackets," for a list of applicable motors.

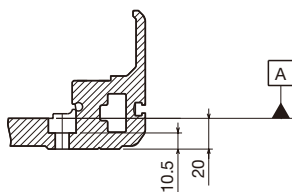

Counter-bore hole on base (detail)

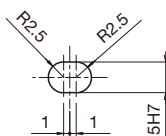

Elongated hole (detail)

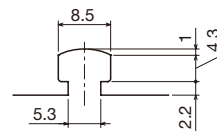

Section B (detail)

	850 (870)	900 (920)	950 (970)	1000 (1020)	1050 (1070)	1100 (1120)	1150 (1170)	1200 (1220)	1250 (1270)	1300 (1320)	1350 (1370)	1400 (1420)	1450 (1470)	1500 (1520)	1550 (1570)	1600 (1620)	1650 (1670)	1700 (1720)
	1010	910	820	750	680	620	570	530	490	460	420	400	370	350	330	310	290	270
	1920	1730	1570	1430	1310	1210	1110	1030	950	890	830	770	720	680	640	600	570	530
	1190	1240	1290	1340	1390	1440	1490	1540	1590	1640	1690	1740	1790	1840	1890	1940	1990	2040
	840	890	940	990	1040	1090	1140	1190	1240	1290	1340	1390	1440	1490	1540	1590	1640	1690
	-	50	100	150	-	50	100	150	-	50	100	150	-	50	100	150	-	50
	1000	1000	1000	1000	1200	1200	1200	1200	1400	1400	1400	1400	1600	1600	1600	1600	1800	1800
	6	7	7	7	7	8	8	8	8	9	9	9	9	10	10	10	10	11
	42.3	43.7	45.1	46.4	47.7	49.1	50.4	51.8	53.1	54.4	55.9	57.2	58.6	59.9	61.2	62.6	63.9	65.3

## Sensors

Various types of sensors can be mounted using a T slot on the side surface of the base. Select a sensor by specifying the appropriate option symbol. The standard sensor is mounted inside the actuator.

Description	Type	Symbol
Standard US8 [x 1], USW12/16/20 [x 3] (Home position on motor side)	US8: APM-D3A1 (Azbil Corp.) USW12/16/20: EE-SX674 (Omron Corp.)	P
Standard US8 [x 1], USW12/16/20 [x 3] (Home position opposite motor side)	US8: APM-D3A1 (Azbil Corp.) USW12/16/20: EE-SX674 (Omron Corp.)	Q
None	-	N
Photo sensor * [x 3], Connector [x 3]	EE-SX674 (Omron Corp.), EE-1001 (Omron Corp.)	6
Sensor N.O. contact [x 1] N.C. contact [x 2]	APM-D3A1 (Azbil Corp.) APM-D3B1 (Azbil Corp.)	E
Sensor N.O. contact [x 1] N.C. contact [x 2]	GX-F12A (Panasonic Industrial Devices SUNX Co., Ltd.) GX-F12B (Panasonic Industrial Devices SUNX Co., Ltd.)	J
Sensor N.O. contact [x 1] (PNP output) N.C. contact [x 2] (PNP output)	GX-F12A-P (Panasonic Industrial Devices SUNX Co., Ltd.) GX-F12B-P (Panasonic Industrial Devices SUNX Co., Ltd.)	M

N.O. contact: Normally open contact point

N.C. contact: Normally closed contact point

\* The photo sensors can be switched between ON when lit and ON when unlit.

Notes:

1. The standard sensor for US8 is APM-D3A1 (Azbil Corp.); the standard sensor for USW12/16/20 is EE-SX674 (Omron Corp.).
2. Non-standard sensors (symbol: 6-M) are mounted outside the cover.
3. When motor wrap is selected, a sensor cannot be mounted on the same side as the motor wrap direction of the motor.
4. For closely grouped proximity sensors, the customer must provide sensors with variant frequencies (consult the respective manufacturer for sensor specifications).
5. The unit is shipped with sensors, mounting screws, detecting plates, and connectors mounted.
6. The standard sensor will not be mounted if a different sensor option is selected.

### Sensor-mounting positions: dimensions

#### ■ US6/8

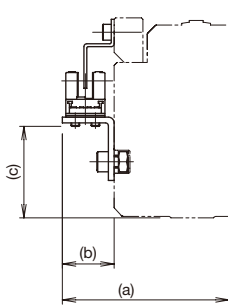

Symbol 6: EE-SX674 (Omron Corp.)

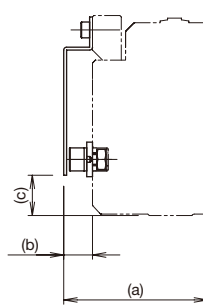

Symbol E: APM-D3\*\* (Azbil Corp.)

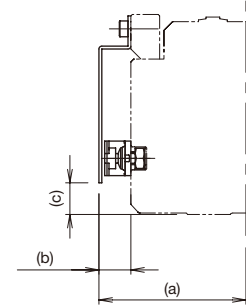

Symbol J, M: GX-F12\*  
(Panasonic Industrial Devices SUNX Co., Ltd.)

#### ■ USW12/16/20

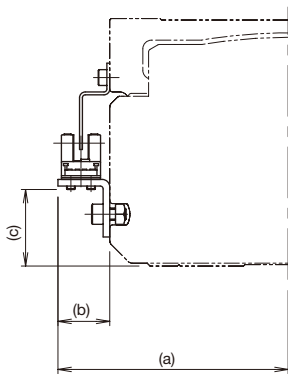

Symbol 6: EE-SX674 (Omron Corp.)

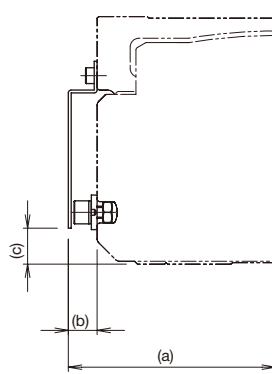

Symbol E: APM-D3\*\* (Azbil Corp.)

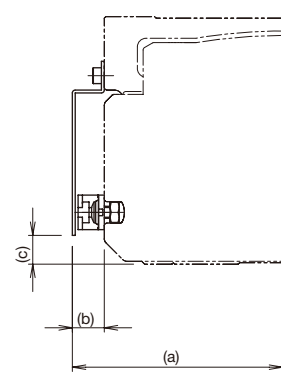

Symbol J, M: GX-F12\*  
(Panasonic Industrial Devices SUNX Co., Ltd.)

Model	a [mm]	b [mm]	c [mm]
US6	50.5	18	36.6
US8	58	18	31.8
USW12	80	18	26.6
USW16	98	18	30.6
USW20	118	18	34.6

Model	a [mm]	b [mm]	c [mm]
US6	43.5	11	23
US8	50	10	14
USW12	72	10	12.5
USW16	91	11	25.5
USW20	111	11	31

Model	a [mm]	b [mm]	c [mm]
US6	43.5	11	23
US8	51.1	11.1	11
USW12	73	11	10
USW16	92	12	29
USW20	112	12	33



# Motor Bracket

Motor brackets are available to mount various kinds of motors. Specify a motor bracket that matches the motor used.

AC servo motor	Motor type		Motor rated output	Flange angle	US6T		US8T		USW12T		USW16T		USW20T			
					Direct coupling	Motor Wrap	Direct coupling	Motor Wrap	Direct coupling	Motor Wrap	Direct coupling	Motor Wrap	Direct coupling	Motor Wrap		
AC servo motor	Yaskawa Electric Corporation	Σ-V	SGMJV-A5	50W	□40	A	A	-	-	-	-	-	-	-		
			SGMAV-A5	100W		A	A	-	-	-	-	-	-			
			SGMJV-01	150W		A	A	-	-	-	-	-	-			
			SGMAV-01	200W		A	A	-	-	-	-	-	-			
			SGMJV-C2	400W		-	-	A	A	-	-	-	-			
			SGMJV-02	750W		-	-	-	-	A	A	-	-			
			SGMAV-02	-		-	-	-	-	A	A	-	-			
			SGMJV-04	-		-	-	-	-	-	-	A	A			
		SGMAV-04	-	-	-	-	-	-	-	A	A					
		SGMJV-08	-	-	-	-	-	-	-	-	-	A	A			
		SGMAV-08	-	-	-	-	-	-	-	-	-	A	A			
		Σ-7	SGM7J-A5	50W	□40	A	A	-	-	-	-	-	-	-	-	
			SGM7A-A5	100W		A	A	-	-	-	-	-	-	-	-	
			SGM7J-01	150W		A	A	-	-	-	-	-	-	-	-	
			SGM7A-01	200W		A	A	-	-	-	-	-	-	-	-	
			SGM7J-C2	400W		-	-	A	A	-	-	-	-	-	-	
			SGM7J-02	750W		-	-	-	-	A	A	-	-	-	-	
			SGM7A-02	-		-	-	-	-	-	-	A	A	-	-	
			SGM7J-04	-		-	-	-	-	-	-	-	-	A	A	
		SGM7A-04	-	-	-	-	-	-	-	-	-	A	A			
	SGM7J-08	-	-	-	-	-	-	-	-	-	-	-	A	A		
	SGM7A-08	-	-	-	-	-	-	-	-	-	-	-	A	A		
	Mitsubishi Electric Corporation	MELSERVO	J3	HF-MP053	50W	□40	A	A	-	-	-	-	-	-	-	
				HF-KP053	100W		A	A	-	-	-	-	-	-	-	
				HF-MP13	150W		A	A	-	-	-	-	-	-	-	
				HF-KP13	200W		A	A	-	-	-	-	-	-	-	
				HF-MP23	400W		-	-	-	-	A	A	-	-	-	-
			HF-KP23	750W	-	-	-	-	-	-	A	A	-	-		
			HF-MP43	-	-	-	-	-	-	-	-	-	A	A	-	
			HF-KP43	-	-	-	-	-	-	-	-	-	A	A	-	
			HF-MP73	-	-	-	-	-	-	-	-	-	-	-	A	A
			HF-KP73	-	-	-	-	-	-	-	-	-	-	-	A	A
		J4	HG-MR053	50W	□40	A	A	-	-	-	-	-	-	-	-	
			HG-KR053	100W		A	A	-	-	-	-	-	-	-	-	
			HG-MR13	150W		A	A	-	-	-	-	-	-	-	-	
			HG-KR13	200W		A	A	-	-	-	-	-	-	-	-	
			HG-MR23	400W		-	-	-	-	A	A	-	-	-	-	
		HG-KR23	750W	-	-	-	-	-	-	A	A	-	-			
		HG-MR43	-	-	-	-	-	-	-	-	-	A	A	-		
		HG-KR43	-	-	-	-	-	-	-	-	-	A	A	-		
		HG-MR73	-	-	-	-	-	-	-	-	-	-	-	A	A	
		HG-KR73	-	-	-	-	-	-	-	-	-	-	-	A	A	
	JN	HF-KN053	50W	□40	A	A	-	-	-	-	-	-	-	-		
		HF-KN13	100W		A	A	-	-	-	-	-	-	-	-		
		HF-KN23	150W		-	-	-	-	A	A	-	-	-	-		
		HF-KN43	200W		-	-	-	-	-	-	A	A	-	-		
	Tamagawa Seiki Co., Ltd.	TBL-III	TS4602	50W	□40	A	A	-	-	-	-	-	-	-		
			TS4603	100W		A	A	-	-	-	-	-	-	-		
			TS4604	150W		-	-	A	A	-	-	-	-	-		
			TS4607	200W		-	-	-	-	A	A	-	-	-		
			TS4609	400W		-	-	-	-	-	-	A	A	-	-	
		TS4614	750W	-	-	-	-	-	-	-	-	A	A			
		TBL-IV	TSM3102	50W	□40	A	A	-	-	-	-	-	-	-	-	
			TSM3104	100W		A	A	-	-	-	-	-	-	-	-	
			TSM3202	200W		-	-	-	-	A	A	-	-	-	-	
			TSM3204	400W		-	-	-	-	-	-	A	A	-	-	
	TSM3304		750W	-		-	-	-	-	-	-	-	A	A		
	Panasonic Corporation	MINAS	A5	MSMD5A	50W	□38	B	B	B	B	-	-	-	-		
				MSMD01	100W		B	B	B	B	-	-	-	-		
				MSMD02	200W		-	-	-	-	B	C	-	-	-	
				MSME02	400W		-	-	-	-	-	-	B	B	-	-
			MSMD04	750W	-	-	-	-	-	-	B	B	-	-		
			MSME04	-	-	-	-	-	-	-	-	-	B	B		
			MSMD08	-	-	-	-	-	-	-	-	-	-	B	B	
			MSME08	-	-	-	-	-	-	-	-	-	-	-	B	B
		A6	MSMF5A	50W	□60	B	B	B	B	-	-	-	-	-		
			MHMF5A	100W		A	A	A	A	-	-	-	-	-		
			MSMF01	200W		B	B	B	B	-	-	-	-	-		
			MHMF01	400W		A	A	A	A	-	-	-	-	-		
			MSMF02	750W		-	-	-	-	B	C	-	-	-		
			MHMF02	-		-	-	-	-	-	-	B	C	-	-	
			MSMF04	-		-	-	-	-	-	-	-	-	B	B	
	MHMF04	-	-	-	-	-	-	-	-	-	B	B				
	MSMF08	-	-	-	-	-	-	-	-	-	-	-	B	B		
	MHMF08	-	-	-	-	-	-	-	-	-	-	-	B	B		
	Keyence Corporation	SV	SV-M005	50W	□40	A	A	-	-	-	-	-	-	-		
			SV-M010	100W		A	A	-	-	-	-	-	-	-		
			SV-M020	200W		-	-	-	-	A	A	-	-	-		
			SV-M040	400W		-	-	-	-	-	-	A	A	-		
		SV-M075	750W	-	-	-	-	-	-	-	-	A	A			
		SV2	SV2-M005	50W	□40	A	A	-	-	-	-	-	-	-		
			SV2-M010	100W		A	A	-	-	-	-	-	-	-		
			SV2-M020	200W		-	-	-	-	A	A	-	-	-		
	SV2-M040		400W	-		-	-	-	-	-	A	A	-			
	SV2-M075	750W	-	-	-	-	-	-	-	-	A	A				
	Sanyo Denki Co., Ltd.	SANMOTION R	R2E-A04008	80W	□40	A	-	A	-	-	-	-	-	-		
			R2-A04010	100W		A	-	A	-	-	-	-	-	-		
			R2-A06020	200W		-	-	-	-	A	-	-	-	-		
			R2A-A06040	400W		-	-	-	-	-	-	A	-	-		
			R2A-A08075	750W		-	-	-	-	-	-	-	-	A	-	
	OMRON Corporation	OMNUC G5	R88M-K05030	50W	□40	-	A	-	-	-	-	-	-	-		
			R88M-K10030	100W		-	A	-	-	-	-	-	-	-		
			R88M-K20030	200W		-	-	-	-	C	B	-	-	-		
			R88M-K40030	400W		-	-	-	-	-	-	B	B	-		
		R88M-K75030	750W	-	-	-	-	-	-	-	-	B	B			
		1S	R88M-1M10030	100W	□40	A	-	A	-	-	-	-	-	-		
			R88M-1M20030	200W		-	-	-	-	B	-	-	-	-		
			R88M-1M40030	400W		-	-	-	-	-	-	B	-	-		
	R88M-1M75030		750W	-		-	-	-	-	-	-	-	B	-		

Notes:

1. Consult THK before installing a motor other than those listed above.
2. For US6 and 8 with motor wrap type, use a two-surface D-cut motor output shaft. Note that Mitsubishi motors support only one-surface D-cut output shafts; consult the manufacturer for further details.
3. For USW12, 16, and 20 with motor wrap type, use a straight motor output shaft.
4. Motor model number in the table shows the main part of the model number only. For more details, please refer to catalogs from each motor manufacturers.

## Static Permissible Load and Static Permissible Moment

Model		US6	US8	USW12	USW16	USW20	
Static permissible load * <sup>1</sup> [N]	Radial direction	17100	45400	96800	153600	209600	
	Reverse radial direction	16753	28599	14300	24007	24007	
	Lateral direction	3651	7520	3760	6488	6488	
	Axial direction	1740 (Direct motor coupling)	2095 (100W, direct motor coupling)		3330	3760	2571
			2689 (100W, motor wrap)				
1288 (Motor wrap)		1047 (150W, direct motor coupling)					
		1345 (150W, motor wrap)					
Static permissible moment * <sup>2</sup> [N·m]	M <sub>A</sub>	123	287	915	2161	1921	
	M <sub>B</sub>	127	235	317	740	793	
	M <sub>C</sub>	138	226	786	1681	2221	

\*<sup>1</sup> The static permissible load is determined by the tightening strength for bolts and the static load ratings of the LM guide portion, ball screw portion, and support bearing.

\*<sup>2</sup> The static permissible moment is the maximum moment that can be applied in each direction while the product is stationary. For details on the nominal life, visit the THK Technical Support website.

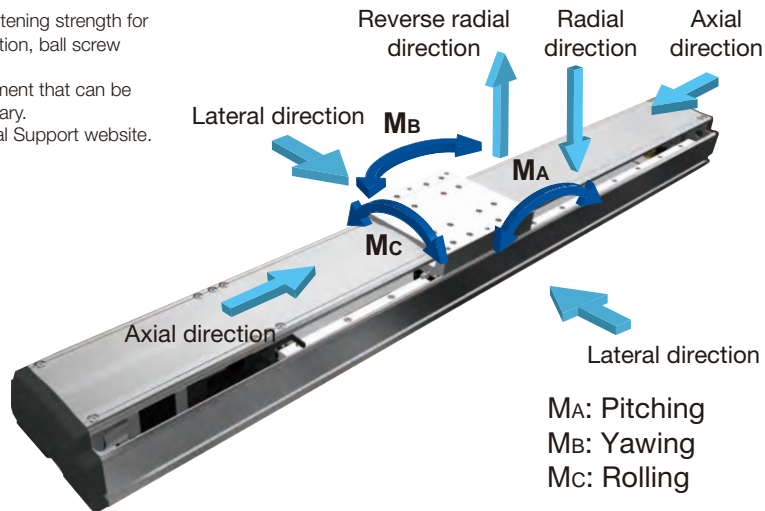

## Geometrical Moment of Inertia

### ■ US6/8

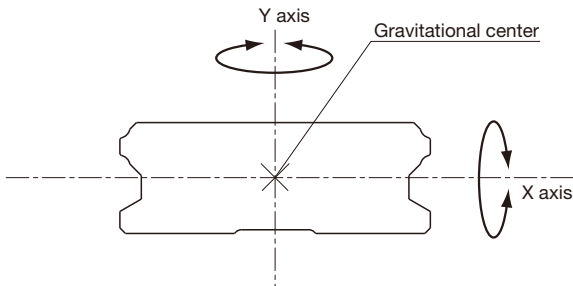

### ■ USW12/16/20

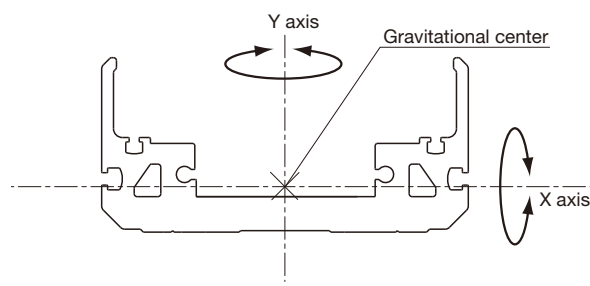

Model	I <sub>x</sub> [mm <sup>4</sup> ]	I <sub>y</sub> [mm <sup>4</sup> ]	Weight [kg/m]
US6	2.80×10 <sup>3</sup>	5.20×10 <sup>4</sup>	2.97
US8	1.11×10 <sup>4</sup>	7.74×10 <sup>4</sup>	4.61
USW12	4.07×10 <sup>5</sup>	4.62×10 <sup>6</sup>	6.67
USW16	1.27×10 <sup>6</sup>	1.22×10 <sup>7</sup>	11.55
USW20	2.19×10 <sup>6</sup>	2.67×10 <sup>7</sup>	16.06

## Recommended Coupling

The recommended couplings for the US/USW universal series are shown below.

Actuator model	Standard coupling			Recommended coupling (1)			Recommended coupling (2)		
	Type	Manufacturer	Inertial moment [kg·cm <sup>2</sup> ]	Type	Manufacturer	Inertial moment [kg·cm <sup>2</sup> ]	Type	Manufacturer	Inertial moment [kg·cm <sup>2</sup> ]
US6	NES20W-N8C×N8C	TSUBAKI E & M CO.	0.034	SFC-020DA2_C	Miki Pulley Co., LTD.	0.034	XBW-25C2	Nabeya Bi-tech Kaisha	0.023
US8	NES20W-N8C×N10C	TSUBAKI E & M CO.	0.034	SFC-020DA2_C		0.034	XBW-25C2		0.023
USW12	SDWA31C-10×14	SUN GIL	0.075	SFC-030DA2_B		0.095	XBW-34C3		0.090
USW16	SDWA31C-12×14	SUN GIL	0.075	SFC-035DA2_C		0.271	XBW-34C3		0.090
USW20	SDWC47C-12×19	SUN GIL	0.550	SFC-040DA2_B		0.363	XBW-39C2		0.210

## Hanging Jig

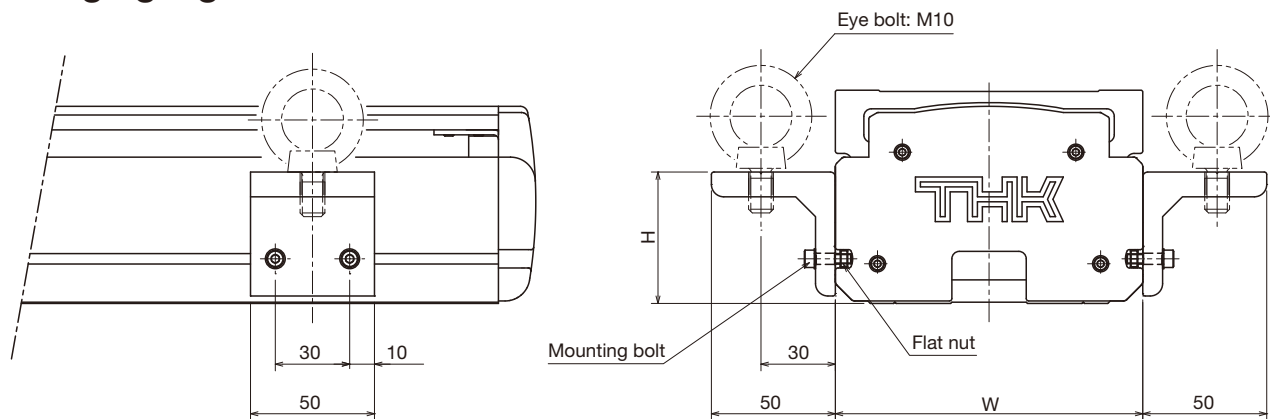

[mm]

Model	W	H
USW12	124	53
USW16	160	52
USW20	200	56

Notes:

- THK recommends using hanging jigs when the weight of the main actuator unit exceeds 20kg.
- Hanging jigs are suitable for use with models USW12/16/20.
- When the unit is shipped with hanging jigs mounted to the actuator, the customer must provide four M10 eyebolts (JIS B 1169 equivalent).
- When a 6, E, J, or M sensor option has been selected and the unit is shipped with hanging jigs mounted to the actuator, the sensor should be mounted at the end of the base on the motor side.
- Hanging jigs can be ordered a separate item: Model USW \_\_ -HANG (4 hanging jigs and 4 flat nuts). The customer must provide eight mounting bolts and four eyebolts.

Model	Recommended mounting bolt
USW12	Hexagonal-socket-head type bolt, M4-15L
USW16	Hexagonal-socket-head type bolt, M5-15L
USW20	Hexagonal-socket-head type bolt, M5-15L

## Motor Selection

Consult the table below when selecting a motor for use with a US/USW. For motor specifications and guidance on selecting a motor, contact the motor manufacturer.

Actuator		Ball screw				
Model	Stroke *1 [mm]	Lead [mm]	Model	Shaft diameter [mm]	Shaft length *2 [mm]	Outer diameter of shaft end [mm]
US6	100	06	WHF1206-3.6	12	315 (328)	φ8h7
	900				1115 (1128)	
	100	12	WHF1212-1.45	12	315 (328)	φ8h7
	900				1115 (1128)	
US8	100	05	BTK1605-2.6	16	378.5 (384.5)	φ10h7
	1100				1378.5 (1384.5)	
	100	10	BNK1510-2.8	15	378.5 (384.5)	φ10h7
	1100				1378.5 (1384.5)	
	100	20	BNK1520-1.5	15	378.5 (384.5)	φ10h7
	1100				1378.5 (1384.5)	
	100	30	WTF1530-1.7	15	378.5 (384.5)	φ10h7
	1100				1378.5 (1384.5)	
USW12	100	05	BTK1605-2.6	16	358 (394)	φ10h7
	1100				1358 (1394)	
	100	10	BNK1510-2.8	15	358 (394)	φ10h7
	1100				1358 (1394)	
	100	20	BNK1520-1.5	15	358 (394)	φ10h7
	1100				1358 (1394)	
	100	30	WTF1530-1.7	15	358 (394)	φ10h7
	1100				1358 (1394)	
USW16	100	10	BNK2010-2.5	20	387 (424)	φ12h7
	1500				1787 (1824)	
	100	20	WHF2020-1.7	20	387 (424)	φ12h7
	1500				1787 (1824)	
	100	40	WHF2040-1.7	20	387 (424)	φ12h7
	1500				1787 (1824)	
USW20	200	20	WHF2020-1.7	20	478 (526)	φ12h7
	1700				1978 (2026)	
	200	40	WHF2040-1.7	20	478 (526)	φ12h7
	1700				1978 (2026)	

\*1 For further information on stroke, see the specifications for each model.

\*2 Ball screw shaft length. Shaft lengths for motor wrap type are shown in parentheses.

Actuator model	LM Guide model	Weight of moving element [kg]	Sliding resistance [N]
US6	SRS15W	1.0	10.0
US8	SHW27CR	2.0	23.0
USW12	SHS15V	2.5	27.4
USW16	SHS20V	4.7	40.1
USW20	SHS25V	6.0	54.2

Permissible input torque		
Actuator model	Direct motor coupling [N·m]	Motor wrap [N·m]
US6	1.67	1.23
US8	1.67	2.14
USW12	2.65	2.65
USW16	5.98	5.98
USW20	8.18	8.18

Coupling	
Actuator model	Inertial moment [kg·cm <sup>2</sup> ]
US6	0.034
US8	0.034
USW12	0.075
USW16	0.075
USW20	0.550

Timing pulley	
Actuator model	Inertial moment [kg·cm <sup>2</sup> ]
US6RT	0.06
US8RT	0.20
USW12RT	0.66
USW16RT	0.68
USW20RT	1.30

For further details on timing pulleys, contact THK.





# Precautions on Use

## ● Application

- This product cannot be applied to any equipment or system that may be used under a life-threatening condition.
- If you are considering using this product for special applications such as mobile vehicles, medical uses, aerospace, or thermonuclear power generation or a power plant, make sure to contact THK for applicability beforehand.

## ● Handling

- Do not disassemble this product unless absolutely necessary. This will cause dust to enter the product resulting in loss of functionality.
- Take care not to drop or strike this product. This could cause injury or product damage or impair the product's function even if the product looks intact.
- Exceeding the maximum recommended speed could damage components or cause an accident. Be sure to use the product within the specification range designated by THK.
- Foreign material entering the product will cause damage to the ball circulation components and loss of functionality. Prevent foreign material, such as dust or cutting chips, from entering the system.
- Using the product in an environment where coolant can penetrate the inner block could cause malfunction, depending on the type of the coolant. Contact THK for details.
- The service temperature range of this product is 0 to 40°C (no freezing or condensation). Consult THK before attempting to use the product outside this temperature range.
- Contact THK before attempting to use the product in a location exposed to vibration or abnormally high or low temperatures, or in a vacuum or clean room.
- When the product is operating or in the ready state, never touch a moving part. In addition, do not enter the operating area.
- If two or more people are involved in the operation, confirm the procedures in advance, and appoint another person to monitor the operation.

## ● Environment

- An indoor location and ambient temperatures from 0 to 40°C, and humidity of 80%RH or below (no freezing or condensation).

Wrong environment can cause failures of the actuator and driver. The best place to use the product is as follows:

- A place free from corrosive gas and flammable gas.
- A place where vibration or impact is not transmitted to the unit.
- A place free from electrically conductive powder (such as iron powder), dust, oil mist, cutting fluid, moisture, salt, and organic solvent.
- A place free from direct sunlight and radiant heat.
- A place free from strong electric and magnetic fields.
- A place that is easily accessible for service and cleaning purposes.
- When using the product in locations exposed to constant vibrations or in special environments such as vacuum or abnormally high or low temperatures, contact THK in advance.

## ● Mounting Surface

- The surface should be the plane that has the precision of machining or the equivalent of that. Some products specify the required flatness.

When you wish to use the product with QZ in a position other than horizontal (such as wall mount and vertical posture), contact THK.



## ● Lubrication

- In order to effectively use the actuator, lubrication is required. Insufficient lubrication may increase abrasion on the rolling part and cause early failure.
- Do not use a mix of lubricants with different physical properties. Note that encapsulated lubricant types vary depending on products.
- Please contact THK if using special lubricants.
- THK recommend the greasing interval to be approximately every 100km. However, it may vary depending on the usage conditions, so THK recommends determining a greasing interval during the initial inspection.
- If the product is to be used in a location exposed to vibrations or in a special environment such as vacuum, or abnormally high or low temperatures, or in a clean room, normal lubricants may not be used. Contact THK for details.
- When adopting an oil lubrication method, contact THK.

## ● Storage

- When storing this actuator, enclose it in a package designated by THK and store it in a horizontal position away from abnormally high or low temperatures and high humidity.

## ● Instruction Manual

- Instruction Manuals can be downloaded from the website (a login process may be required).  
THK Technical Support site <https://tech.thk.com/>  
"Universal series US/USW Instruction Manual"  
and other contents including CAD data and PC software (D-STEP) can also be downloaded.

**ACTUATOR  
UNITS**

# Universal Series US/USW

- **LM Guide**, and  are registered trademarks of THK CO., LTD.
  - The actual products may differ from the pictures and photographs in this catalog.
  - Outward appearances and specifications are subject to change without notification for the purpose of improvement.
  - Although great care has been taken in the production of this catalog, THK will not take any responsibility for damage resulting from typographical errors or omissions.
  - In exporting our products and technology, or selling them for the purpose of export, THK has a basic policy of observing laws relating to foreign exchange, trade and other laws.
- For export of THK products as single items, please contact THK in advance.

All rights reserved.

## THK CO., LTD.

Head Office 3-11-6 Nishigotanda, Shinagawa-ku, Tokyo 141-8503 JAPAN  
 International Sales Department Phone:+81-3-5434-0351 Fax:+81-3-5434-0352  
 Global site : <http://www.thk.com/>

**NORTH AMERICA**

THK America, Inc.

● **HEADQUARTERS**

Phone:+1-847-310-1111 Fax:+1-847-310-1271

● **CHICAGO OFFICE**

Phone:+1-847-310-1111 Fax:+1-847-310-1182

● **NORTH EAST OFFICE**

Phone:+1-631-244-1565 Fax:+1-631-244-1565

● **ATLANTA OFFICE**

Phone:+1-770-840-7990 Fax:+1-770-840-7897

● **LOS ANGELES OFFICE**

Phone:+1-949-955-3145 Fax:+1-949-955-3149

● **SAN FRANCISCO OFFICE**

Phone:+1-925-455-8948 Fax:+1-925-455-8965

● **DETROIT OFFICE**

Phone:+1-248-858-9330 Fax:+1-248-858-9455

● **TORONTO OFFICE**

Phone:+1-905-820-7800 Fax:+1-905-820-7811

**SOUTH AMERICA**

THK BRAZIL INDUSTRIA E COMERCIO LTDA.

Phone:+55-11-3767-0100 Fax:+55-11-3767-0101

**EUROPE**

THK GmbH

● **EUROPEAN HEADQUARTERS**

Phone:+49-2102-7425-555 Fax:+49-2102-7425-556

● **DÜSSELDORF OFFICE**

Phone:+49-2102-7425-0 Fax:+49-2102-7425-299

● **STUTTGART OFFICE**

Phone:+49-7141-4988-500 Fax:+49-7141-4988-888

● **U.K. OFFICE**

Phone:+44-1384-47-1550 Fax:+44-1384-47-1551

● **ITALY OFFICE**

Phone:+39-02-9901-1801 Fax:+39-02-9901-1881

● **SWEDEN OFFICE**

Phone:+46-8-445-7630 Fax:+46-8-445-7639

● **AUSTRIA OFFICE**

Phone:+43-7229-51400 Fax:+43-7229-51400-79

● **SPAIN OFFICE**

Phone:+34-93-652-5740 Fax:+34-93-652-5746

● **TURKEY OFFICE**

Phone:+90-216-362-4050 Fax:+90-216-569-7150

● **PRAGUE OFFICE**

Phone:+420-2-41025-100 Fax:+420-2-41025-199

● **MOSCOW OFFICE**

Phone:+7-495-649-80-47 Fax:+7-495-649-80-44

THK Europe B.V.

● **EINDHOVEN OFFICE**

Phone:+31-040-290-9500 Fax:+31-040-290-9599

THK France S.A.S.

● **PARIS OFFICE**

Phone:+33-1-7425-3800 Fax:+33-1-7425-3799

**CHINA**

THK (CHINA) CO.,LTD.

● **HEADQUARTERS**

Phone:+86-411-8733-7111 Fax:+86-411-8733-7000

● **SHANGHAI OFFICE**

Phone:+86-21-6219-3000 Fax:+86-21-6219-9890

● **BEIJING OFFICE**

Phone:+86-10-8441-7277 Fax:+86-10-6590-3557

● **CHENGDU OFFICE**

Phone:+86-28-8526-8025 Fax:+86-28-8525-6357

● **GUANGZHOU OFFICE**

Phone:+86-20-8523-8418 Fax:+86-20-3801-0456

● **SHENZHEN OFFICE**

Phone:+86-755-2642-9587 Fax:+86-755-2642-9604

● **XIAN OFFICE**

Phone:+86-29-8834-1712 Fax:+86-29-8834-1710

THK (SHANGHAI) CO.,LTD.

Phone:+86-21-6275-5280 Fax:+86-21-6219-9890

**TAIWAN**

THK TAIWAN CO.,LTD.

● **TAIPEI HEAD OFFICE**

Phone:+886-2-2888-3818 Fax:+886-2-2888-3819

● **TAICHUNG OFFICE**

Phone:+886-4-2359-1505 Fax:+886-4-2359-1506

● **TAINAN OFFICE**

Phone:+886-6-289-7668 Fax:+886-6-289-7669

**KOREA**

SEOUL REPRESENTATIVE OFFICE

Phone:+82-2-3468-4351 Fax:+82-2-3468-4353

**SINGAPORE**

THK LM System Pte. Ltd.

Phone:+65-6884-5500 Fax:+65-6884-5550

**THAILAND**

THK RHYTHM(THAILAND) CO., LTD. LM System Division

● **Bangkok Branch**

Phone:+66-2751-3001 Fax:+66-2751-3003

**INDIA**

THK India Pvt. Ltd.

● **HEADQUARTERS & Bangalore Branch**

Phone:+91-80-2340-9934 Fax:+91-80-2340-9937

● **Pune Branch**

Phone:+91-20-4120-8742

● **Chennai Branch**

Phone:+91-44-4042-3132

● **Ahmedabad Branch**

Phone:+91-79-6134-4925

● **Delhi Branch**

Phone:+91-12-4676-8695