



Caged-Ball High-Load Ball Screw

High load capacity

High speed

Low torque fluctuation

Low noise and long-term maintenance-free operation

HBN

The internal structure designed to provide optimum operation even under high-load conditions



Caged-Ball High-Load Ball Screw

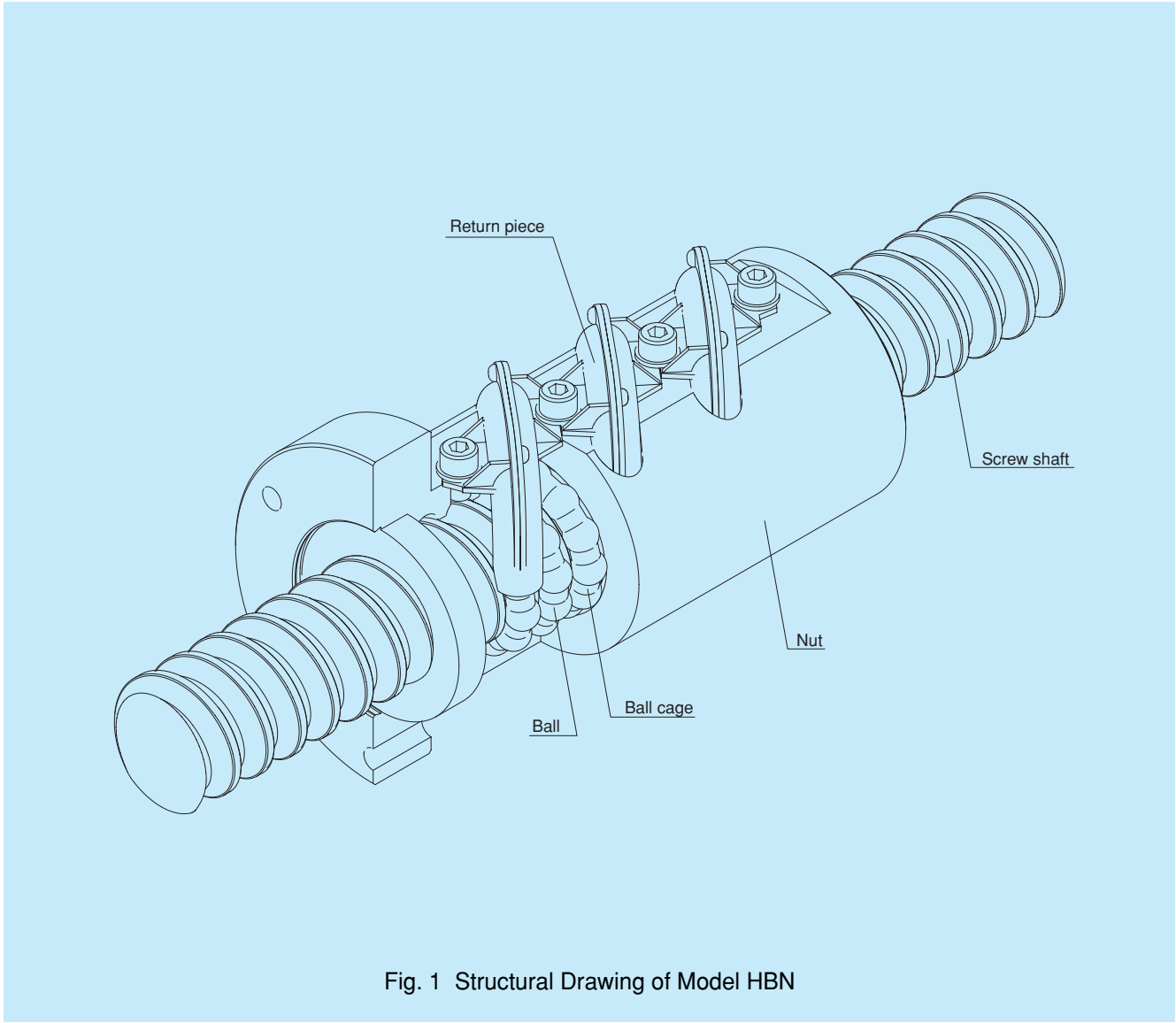

Fig. 1 Structural Drawing of Model HBN

Construction

Caged-Ball high-load ball screw model HBN is characterized by its internal structure design optimum for operation under high-load conditions and, thus, by a significantly enhanced load rating as compared with conventional ball screws.

Model HBN is provided with a ball cage that encases the balls to eliminate ball-to-ball collisions and friction and improve the retention of a lubricant. This allows a longer service life, lower noises, and lower torque fluctuation even under high-load conditions.

Model HBN supports a circulating mechanism with enhanced strength that allows the return piece to pick up balls in the near tangential direction. The circulating mechanism makes the use with DN value 130,000 possible.

We have developed current state-of-the-art manufacturing technologies for Caged-Ball LM Guides and Caged-Ball Ball Screw model SBN while making the most of our long experiences. Our Caged-Ball high-load ball screw is designed optimally to enable high-power transfer, offering the following significant features.

Features

High load

The HBN has the internal structure suitable for a high load. It takes full advantage of the ball cage, being resistant to the load rating load more than twice higher that of the conventional product.

High speed

The return piece for the HBN is based on the circulating mechanism that picks up balls in the near tangential direction. The nearly ideal circulating mechanism allows balls to run unforcedly. It enables the use of the return piece and the ball cage designed to provide sufficient strength, under the DN value rated at 130,000.

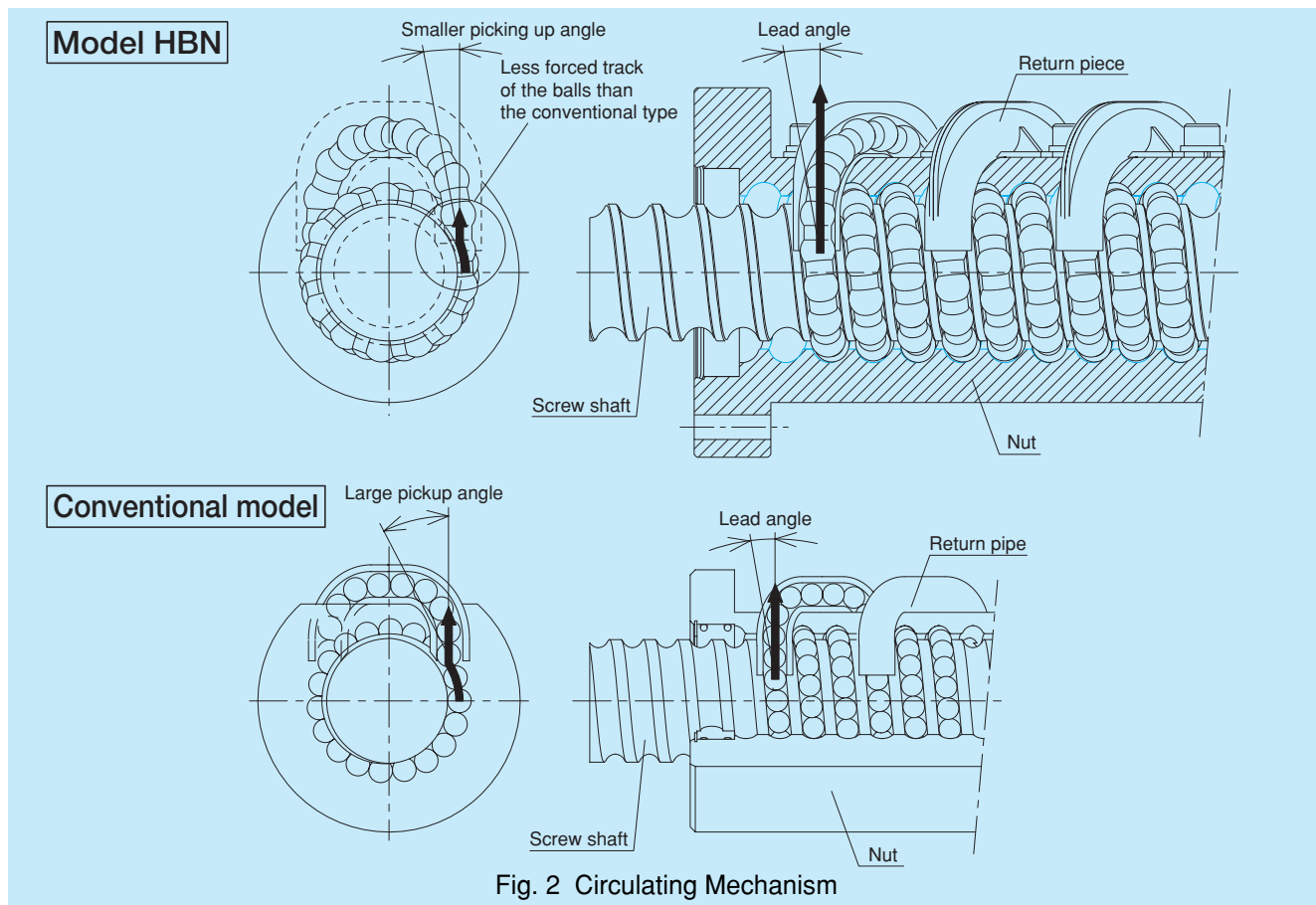

Smooth motion

The use of a ball cage eliminates ball-to-ball friction, offering higher durability, lower dynamic torque fluctuation, and smoother motion.

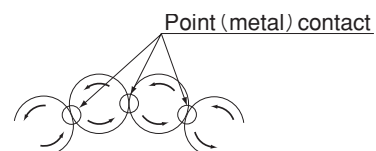

Conventional structure

Low noise

The use of a ball cage eliminates collision noise. The return piece has no lips and picks up balls and is also capable of suppressing collision noise. It contributes to implementing operation under lower noises.

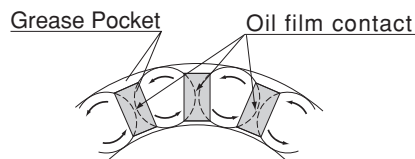

Caged-ball technology

Performance

■Data for evaluating load durability

The HBN has the internal structure that is suitable for high loads and takes full advantage of the ball cage. It, therefore, provides excellent load durability.

Load durability testing

Test piece : HBN5016—7. 5RRG2+700LC7

Data

Applied load	118kN
Stroke	48mm
Travel speed	Up to 3.8m/min
Shaft rotation speed	Up to 240min ⁻¹
Lubrication	Grease lubrication(LUBE LUBER MY-2)

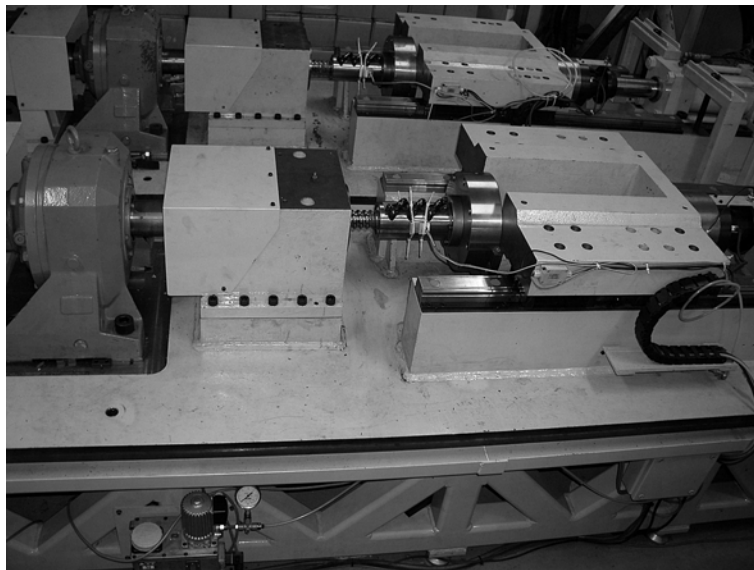

Load durability tester

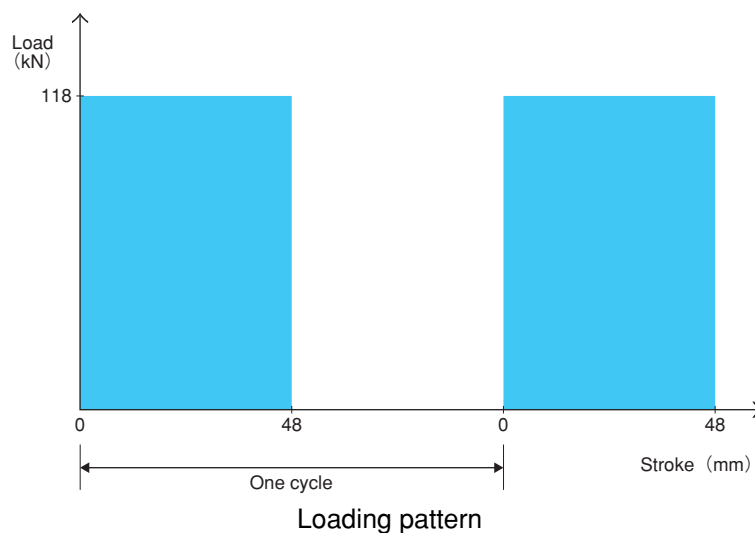

Result

The HBN has incurred no errors over 3 million cycles of running. (Still running)

■Data for evaluating high-speed durability

The HBN supports the circulating mechanism that picks up balls in the near tangential direction. The return piece and the ball cage are designed to provide sufficient strength. The HBN, therefore, offers excellent high-speed durability.

High-speed durability testing

Test piece : HBN5016—7. 5RRG2+1200LC7

Data

Stroke	480mm
Travel speed	Up to 40m/min
Acceleration	Up to 9.8m/s ²
Shaft rotation speed	Up to 2500min ⁻¹
Lubrication	Grease lubrication(LUBE LUBER MY-2)

Result

The HBN has incurred no errors over 2,000 km of running. (Still running)

■Data for evaluating motion

The HBN contains a ball cage that eliminates mutual ball friction. It, therefore, offers smoother revolution motion.

Torque measurement

Test piece : HBN5016—7. 5RRG2+1200LC7

Data

Stroke	200mm
Travel speed	16m/min
Shaft rotation speed	60min ⁻¹
Lubrication	Grease lubrication(LUBE LUBER MY-2)

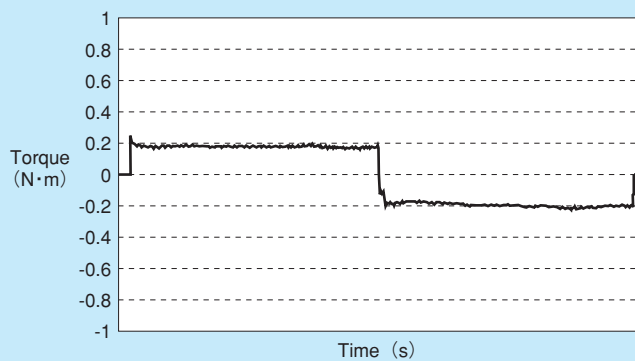

Fig. 3 Torque measurements

■Data for evaluating noise

The HBN contains a ball cage that suppresses the sound generated when balls collide with each other. It is, therefore, accompanied by less noise.

Noise measurement

Test pieces : HBN3210—5RRG2+994LC7
 : BNF3210—5RRG2+994LC7

Data

Stroke	600mm
Lubrication	Grease lubrication(LUBE LUBER MY-2)

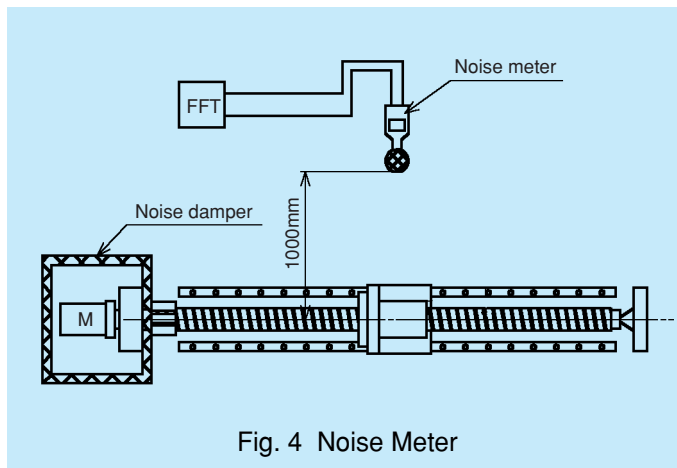

Fig. 4 Noise Meter

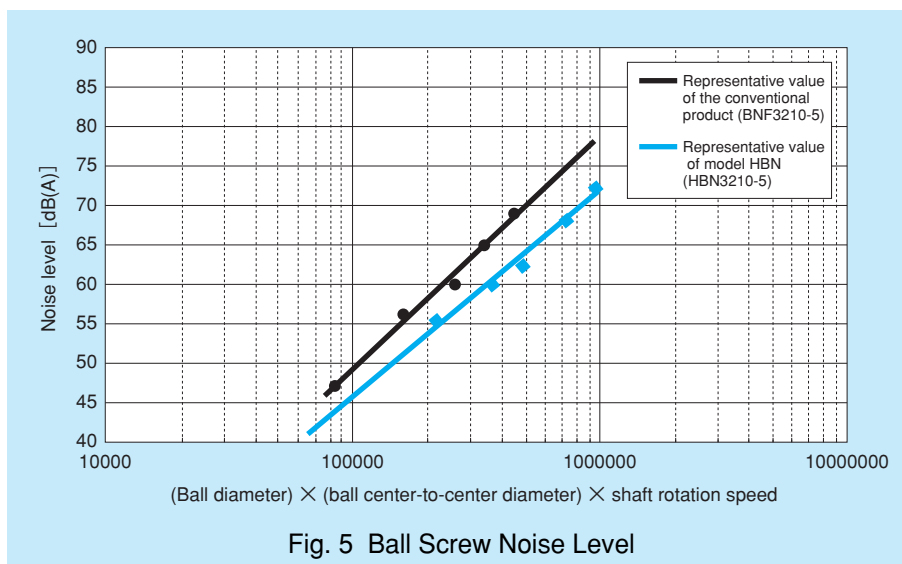

Fig. 5 Ball Screw Noise Level

Accuracy Standard and Axial Clearance

Accuracy standard

The THK high-load ball screw is manufactured according to JIS B 1192 (precision ball screw) in terms of accuracy. The lead accuracy is measured using a reliable laser instrument for assurance. For details about the standard value, see our general catalog.

Axial clearance

The THK high-load ball screw is accompanied by the standard G2 axial clearance. Ball screws with other clearance are also available if you need them. (See the Table below.) The ball screw with the GT or G1 clearance under C7 may have a partially negative clearance.

Table 5 Axial Clearance

Clearance symbol	GT	G1	G2	G3
Axial clearance	0~0.005	0~0.01	0~0.02	0~0.05

High-Load Ball Screw Installation

Generally, the axial load applied to the ball screw is absorbed by a flange surface. We recommend using the following approach to installation. If the bolt is subject to a tensile load depending on the installation condition, you should fully consider the bolt strength.

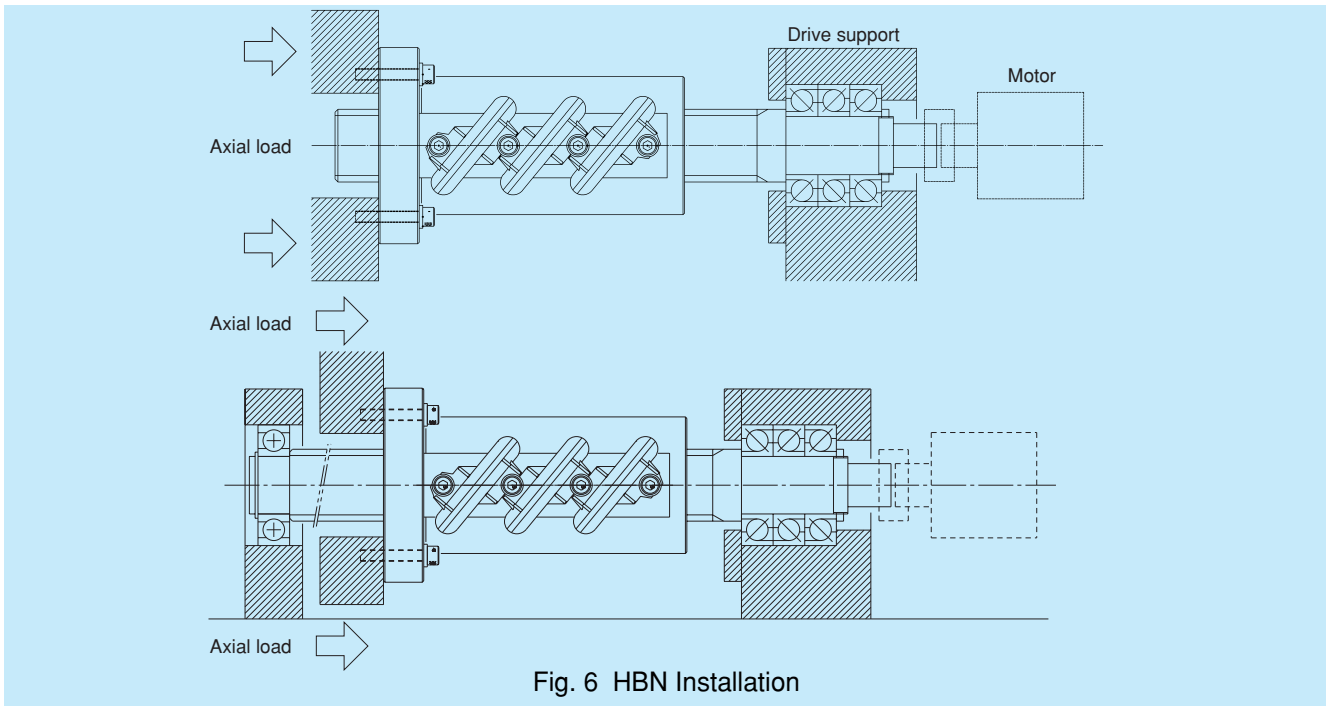

Applications

- Injection molding machine
- Pressing machine
- Blow molding machine
- Extrusion molding machine
- Other machines

In particular,

you can use HBN efficiently instead of a hydraulic cylinder.

Model HBN is more excellent than the hydraulic cylinder in terms of:

1. energy saving (power consumption 1/5 to 1/3 times less than that of the hydraulic cylinder);
2. clean environment;
3. machine controllability;
4. maintainability; and
5. positioning accuracy.

HBN's Dimensions

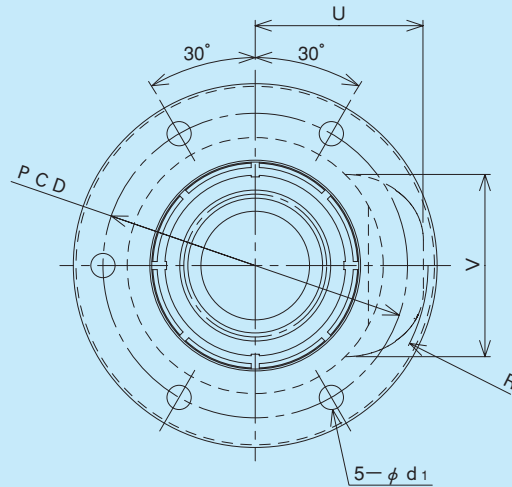

Model No.	Outer screw shaft diameter (mm)	Lead (mm)	Ball center-to-center diameter (mm)	Screw thread minor diameter (mm)	Number of loaded circuits Columns X windings	Basic load rating (kN)		Permissible load (kN)
	d	ℓ	dp	d _c		Ca	Coa	
HBN3210-5	32	10	34.0	26.0	2×2.5	102.9	191.3	31.9
HBN3610-5	36	10	38.0	30.0	2×2.5	108.2	220.4	33.5
HBN4010-7.5	40	10	42.0	34.0	3×2.5	162.6	366.0	50.4
HBN5010-7.5	50	10	52.0	44.0	3×2.5	179.1	462.7	55.5
HBN3612-5	36	12	38.4	29.0	2×2.5	141.1	267.7	43.7
HBN4012-7.5	40	12	42.4	33.0	3×2.5	212.4	441.6	65.8
HBN5012-7.5	50	12	52.4	43.0	3×2.5	235.7	572.2	73.1
HBN5016-7.5	50	16	53.0	39.6	3×2.5	379.6	820.9	117.7
HBN6316-7.5	63	16	66.0	52.6	3×2.5	427.1	1043.8	132.4
HBN6316-10.5	63	16	66.0	52.6	3×3.5	577.1	1461.3	178.9
HBN6320-7.5	63	20	66.5	49.6	3×2.5	578.8	1283.1	179.4

Example of model No. designation

HBN3210-5 **RR** **G2** + **1200L** **C7**

①

②

③

④

⑤

① Model No.

② Seal symbol

(RR:Labyrinth seals at both ends)

③ Axial clearance symbol

④ Overall screw shaft length (in mm)

⑤ Accuracy symbol

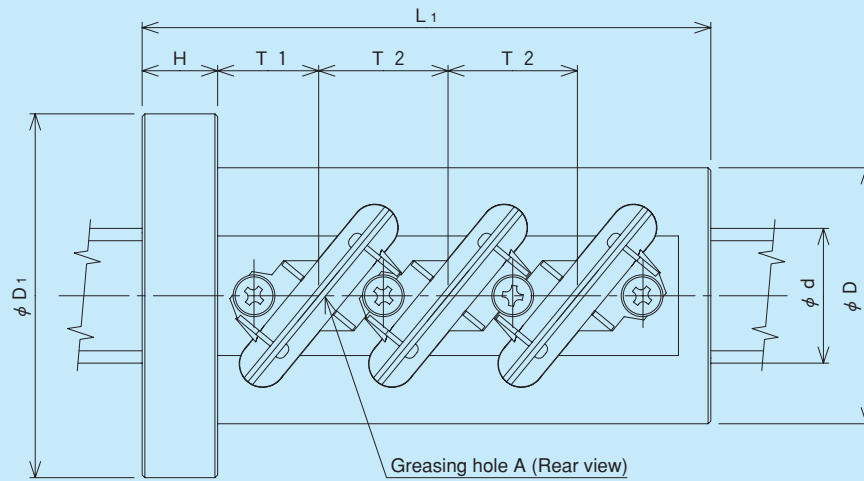

Axial rigidity (N/μm) K	Nut dimensions (mm)											Greasing hole A
	Outer diameter D	Flange diameter D ₁	Overall length L ₁	H	PCD	d ₁	T ₁	T ₂	U _{MAX}	V _{MAX}	R _{MAX}	
1077	58	85	98	15	71	6.6	22	30	42	46	43.5	M6
1176	62	89	98	15	75	6.6	22	30	44	50	46	M6
1910	66	100	135	18	82	9	23.5	30	45.5	54	48	M6
2279	78	112	135	18	94	9	23.5	30	51	63.5	54.5	M6
1207	66	100	116	18	82	9	26	36	48	52.5	50	M6
1922	70	104	152	18	86	9	26	36	50	56	52	M6
2345	80	114	152	18	96	9	26	36	55	66	58.5	M6
2392	95	135	211	28	113	9	37.5	48	63.4	69.6	65.2	PT-1/8
2898	105	139	211	28	122	9	37.5	48	69.5	82	72.5	PT-1/8
4029	105	139	259	28	122	9	53.5	64	69.5	82	73	PT-1/8
3030	117	157	252	32	137	11	44	60	78	86.5	80	PT-1/8