



**ACTUATOR
UNITS**

NEW

Compact series

KRF



For details, visit THK at www.thk.com

* Product information is updated regularly on the THK website.

THK CO., LTD.
TOKYO, JAPAN

CATALOG No.375-11E

Compact Series KRF

High rigidity fully enclosed actuator

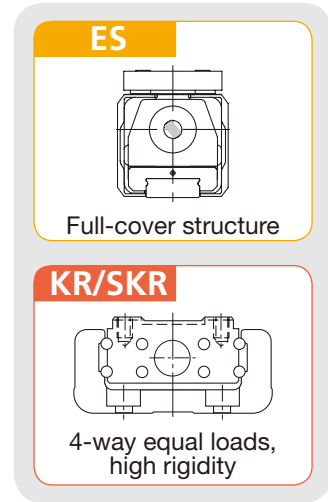
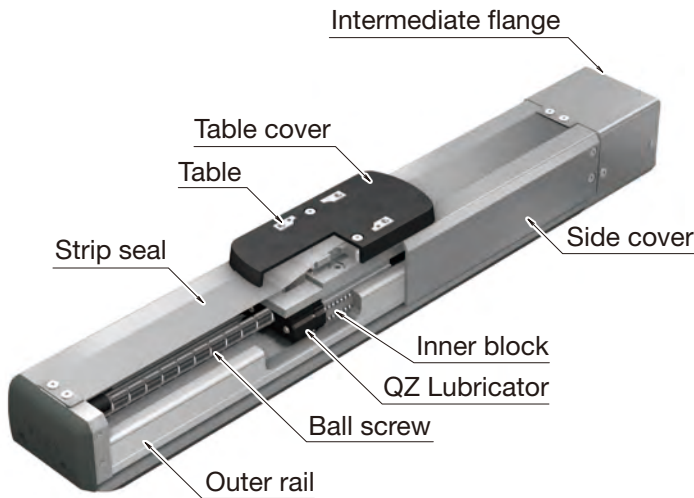

- ✓ Outer rail of KR/SKR with proven history adopted
- ✓ Single axis actuator with high moment rigidity

Supported size (guideline)

KR/SKR	20	26	33
KRF	4	5	6

Features

1 Fully enclosed design

Strip seals on the side cover and upper surface using magnetic attraction method provide a fully enclosed structure. It prevents any problems caused by entering of foreign materials from outside. As well, the top surface of the strip seal is less likely to generate dust by avoiding the contact.

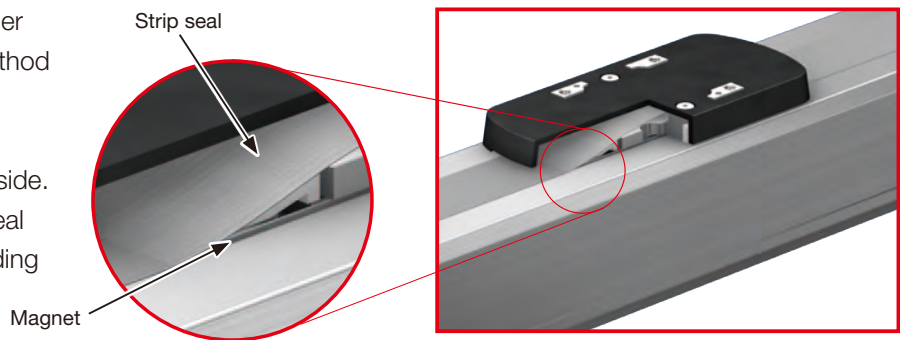

Magnetic attraction method

The magnet built in the side cover attracts the strip seal and prevents it from lifting, reducing the development of clearance.

2 High rigidity

Use of a steel outer rail with a cross-sectional U shape enables to receive larger moment. The actuator body's high rigidity allows for a compact, space-saving design.

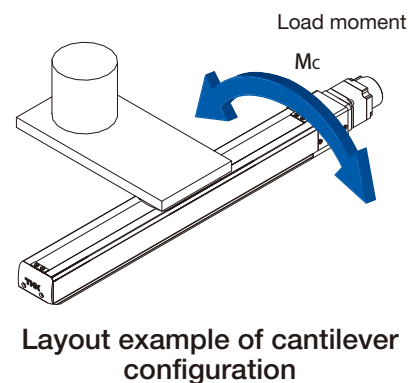
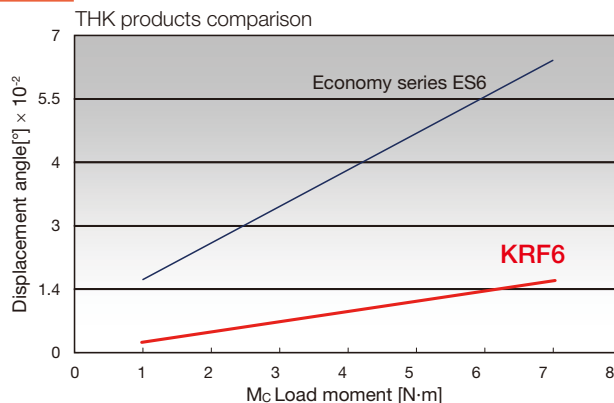

Model configuration

KRF (type without motor)

In the case of actuator main unit only, or when the motor specified by the customer is installed



Model	Ball screw lead	Stroke	Design symbol	With/without motor	Intermediate flange	Motor shaft fixing method	Option
KRF4R	06	0050	A	0	WN	D	MR-SB
(1)	(2)	(3)	(4)	(5)	(6)	(7)	(8)
KRF4	06: 6mm	0050: 50mm	A	0: Without motor	A0: Without intermediate flange	No symbol: Select when directly coupled	No symbol: None
KRF5	10: 10mm	0100: 100mm		1: With motor* (Prepared by THK)	AN	D: D-cut	MR: Motor right wrap*
KRF6		0150: 150mm			AP	K: Key	ML: Motor left wrap*
KRF4R		0200: 200mm			AQ	M: Friction tightening	MD: Motor down wrap*
KRF5R		0250: 250mm			AS		GR: Gray cover
KRF6R		0300: 300mm			AR		SB: Slider base
		0350: 350mm			AU		□1□2: Sensor
		0400: 400mm			AT		
		0450: 450mm			WN		
		0500: 500mm			WP		
		0550: 550mm			WQ		
		0600: 600mm					
		0650: 650mm					
		0700: 700mm					
		0750: 750mm					
		0800: 800mm					

R represents motor wrap.

KRF4, and KRF4R have ball screw lead of 6mm only.

When selecting "0", for motor direct coupling specification, a coupling is not provided. For motor wrap specifications, a timing pulley and timing belt are provided. When selecting "1", the motor you specify will be installed.

*Specify the motor cable orientation separately.

Maximum stroke differs depending on models.
KRF4: 300mm
KRF5: 550mm
KRF6: 800mm

Selectable motor shaft fixing methods differ depending on models.
KRF4R: "D", "K"
KRF5R: "D", "K"
KRF6R: "D", "K", "M"

Specify the option symbol by writing in the order of description from left adding "-".
* This is valid only when selecting KRF□R for model (1).

Change the cover color to gray
You can change the color of housing cover to gray.
Standard: red When GR is selected: gray

Sample model configuration

Main unit only (without motor type)	KRF4-06-0150A-0-AM-GR-L1
Main unit only (when the motor specified by the customer is installed)	KRF5-10-0500A-1-AQ-L6

Pages for detailed description

(6) Intermediate flange	→ P.20
(7) Option	SB: With slider base → P.17
	□1□2: Sensor → P.18
	GR: Change the cover color to gray → P.19

Lineup List

[KRF4, 5]

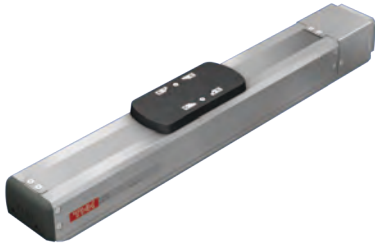

[KRF6]

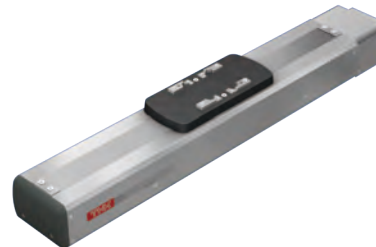

Model	Ball screw lead [mm]	Stroke [mm]	Motor capacity [W]		Maximum load capacity *1 [kg]		
			Stepper motor	Servo motor [W]	Horizontal mount	Wall mount	Vertical mount
KRF4	6	50 to 300	-	50	6	5.5	4
KRF5	6	50 to 550	-	50	19	14	6
	10				15	12.5	3.5
KRF6	6	50 to 800	-	100	35	24	10
	10				30	22	5

*1 The maximum load capacity indicates the capacity at the rated speed under 0.5 G for horizontal mount and wall mount and 0.3 G for vertical mount.

*2 The maximum speed is the value restricted by the motor rotational speed (at 3,000min-1) or by the permissible rotational speed of the ball screw.



	Maximum speed for each stroke *2 [mm/s]																
	Stroke [mm]																
	50	100	150	200	250	300	350	400	450	500	550	600	650	700	750	800	
			300														
					300					250							
					500					430							
					300						260	220	200	170	150		
					500						440	380	330	290	260		

KRF4 without motor



Model Configuration

Model	Ball screw lead	Stroke	Design symbol	With/without motor	Intermediate flange	Option
KRF4	06	0150	A	0	AN	GR-SB

KRF4	06: 6mm	0050: 50mm to 0300: 300mm	A	0: Without motor 1: With motor (Prepared by THK)	A0: Without intermediate flange AN AQ AP AS AR	No symbol: Red cover GR: Gray cover SB: Slider base <input type="checkbox"/> 1 <input type="checkbox"/> 2: Sensor Note: If the GR is not included in the model configuration, cover will be red.
-------------	----------------	---	----------	--	--	---

Basic Specifications

LM guide portion	Basic dynamic load rating C [N]		3590
	Basic Static Load Rating Co [N]		6300
Ball screw portion	Basic dynamic load rating Ca [N]		860
	Basic Static Load Rating Coa [N]		1450
	Screw shaft diameter [mm]		φ6
Ball screw lead [mm]		6	
Bearing portion (Fixed side)	Axial direction	Basic dynamic load rating Ca [N]	1150
		Static Permissible Load Poa [N]	735
Permissible rotational speed [min ⁻¹]			3000
Starting torque *1 [N·m]			0.008
Positioning repeatability *2 [mm]			±0.010
Lost motion *2 [mm]			0.1
Permissible input torque [N·m]			0.355
Static permissible moment *3 [N·m]			MA: 31 MB: 21.2 Mc: 52.7

- *1 The starting torque represents values when the standard grease is filled.
*2 These represent values when measured using a motor provided by THK.
*3 Applied point of moment load for MA and MC are the top face of the table, and that for MB is the center of the table.

Static permissible moment

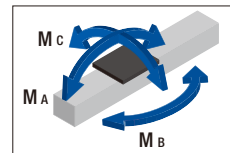

Reference Permissible Overhang Length*

Horizontal use

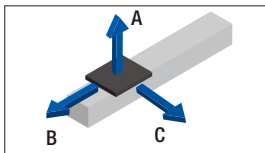

Wall use

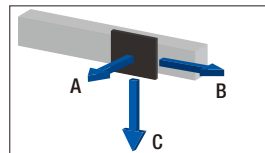

Vertical use

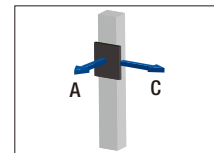

Horizontal mount

[mm]

Ball screw lead [mm]	Load mass [kg]	A	B	C
6	3	250	60	160
	6	110	20	60

Wall mount

[mm]

Ball screw lead [mm]	Load mass [kg]	A	B	C
6	2.5	140	60	280
	5.5	50	20	100

Vertical mount

[mm]

Ball screw lead [mm]	Load mass [kg]	A	C
6	2	100	100
	4	30	30

* This value is the overhang length whose running life is 10,000 km for horizontal mount and wall mount, and 5,000 km for vertical direction. A permissible value of the applied load in each direction.

KRF4

Dimensions

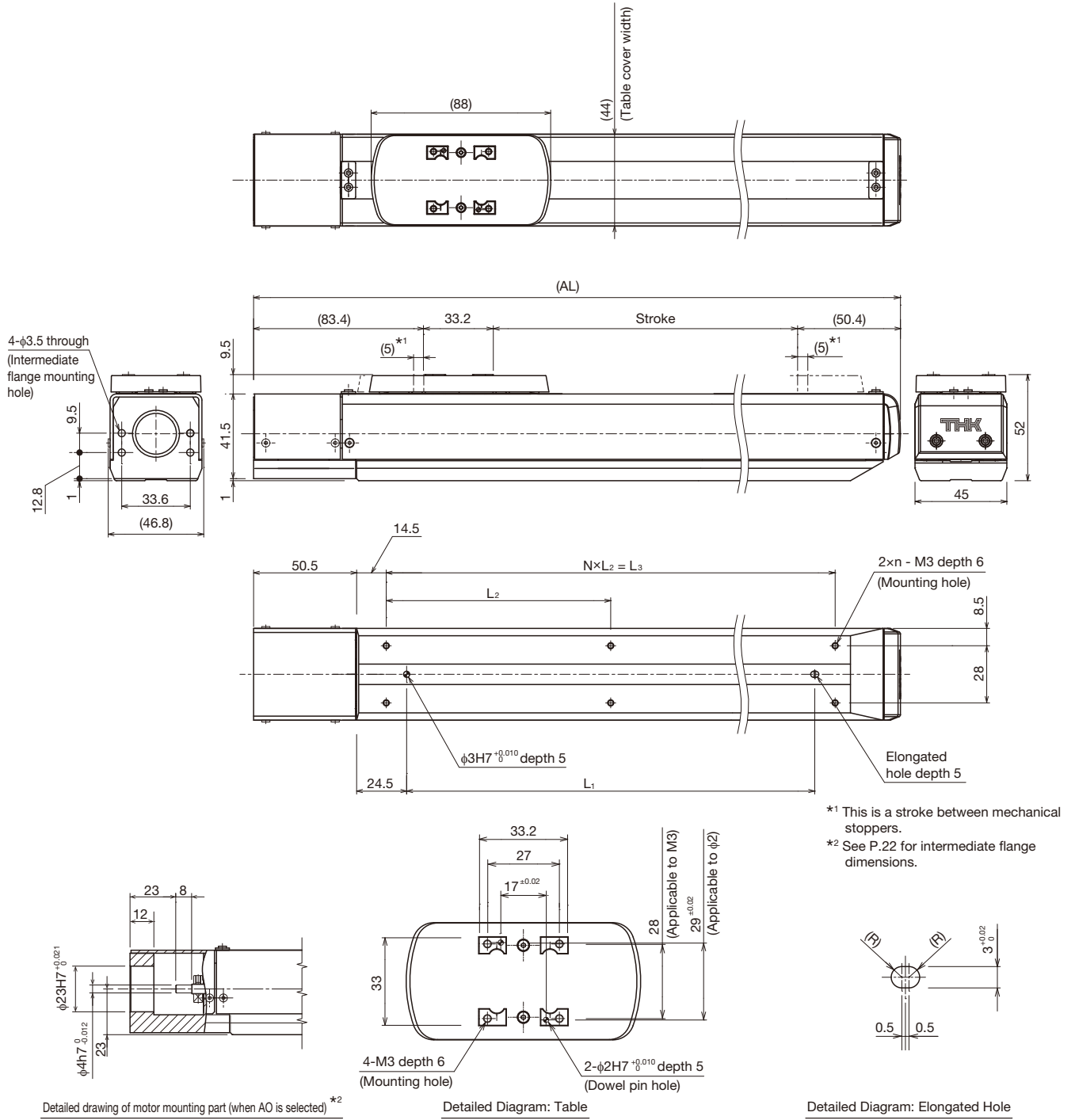

Stroke [mm] (Stroke between mechanical stoppers)		50 (60)	100 (110)	150 (160)	200 (210)	250 (260)	300 (310)
Maximum speed ^{*3 *4} [mm/s]	Ball screw lead: 6mm	300					
Dimensions [mm]	AL	217	267	317	367	417	467
	L1	100	150	200	250	300	350
	L2	120	85	110	90	105	120
	L3	120	170	220	270	315	360
Mounting pitch count	N	1	2	2	3	3	3
Mounting hole count	n	2	3	3	4	4	4
Weight [kg]		1.1	1.3	1.5	1.7	1.9	2.1

^{*3} The maximum speed varies depending on the motor used.

^{*4} The maximum speed is the value restricted by the permissible rotational speed of the ball screw.

KRF4R without motor



Model Configuration

Model	Ball screw lead	Stroke	Design symbol	With/without motor	Intermediate flange	Motor shaft fixing method	Option
KRF4R	06	0150	A	1	WN	D	MR-GR
KRF4R	06 : 6mm	0050 : 50mm to 0300 : 300mm	A	0 : Without motor 1 : With motor (Prepared by THK)	WN WP WQ	D : D-cut K : Key	MR : Motor right wrap ML : Motor left wrap MD : Motor down wrap GR : Gray cover SB : Slider base □1□2 : Sensor

Basic Specifications

LM guide portion	Basic dynamic load rating C [N]	3590	
	Basic Static Load Rating Co [N]	6300	
Ball screw portion	Basic dynamic load rating Ca [N]	860	
	Basic Static Load Rating Coa [N]	1450	
	Screw shaft diameter [mm]	φ6	
	Ball screw lead [mm]	6	
Bearing portion (Fixed side)	Axial direction	Basic dynamic load rating Ca [N]	1150
		Static Permissible Load Poa [N]	735
	Permissible rotational speed [min ⁻¹]	3000	
	Starting torque *1 [N·m]	0.008	
	Positioning repeatability *2 [mm]	±0.010	
	Lost motion *2 [mm]	0.1	
	Permissible input torque [N·m]	0.355	
	Static permissible moment *3 [N·m]	MA: 31 Mb: 21.2 Mc: 52.7	

- *1 The starting torque represents values when the standard grease is filled.
 *2 These represent values when measured using a motor provided by THK.
 *3 Applied point of moment load for MA and MC are the top face of the table, and that for MB is the center of the table.

Static permissible moment

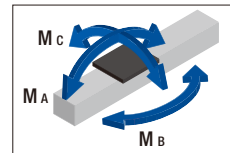

Reference Permissible Overhang Length*

Horizontal use

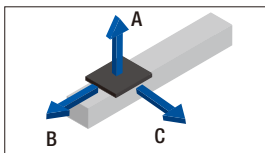

Wall use

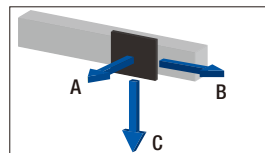

Vertical use

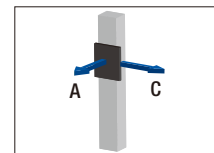

Horizontal mount

[mm]

Ball screw lead [mm]	Load mass [kg]	A	B	C
6	3	250	60	160
	6	110	20	60

Wall mount

[mm]

Ball screw lead [mm]	Load mass [kg]	A	B	C
6	2.5	140	60	280
	5.5	50	20	100

Vertical mount

[mm]

Ball screw lead [mm]	Load mass [kg]	A	C
6	2	100	100
	4	30	30

* This value is the overhang length whose running life is 10,000 km for horizontal mount and wall mount, and 5,000 km for vertical direction. A permissible value of the applied load in each direction.

KRF4R

Dimensions

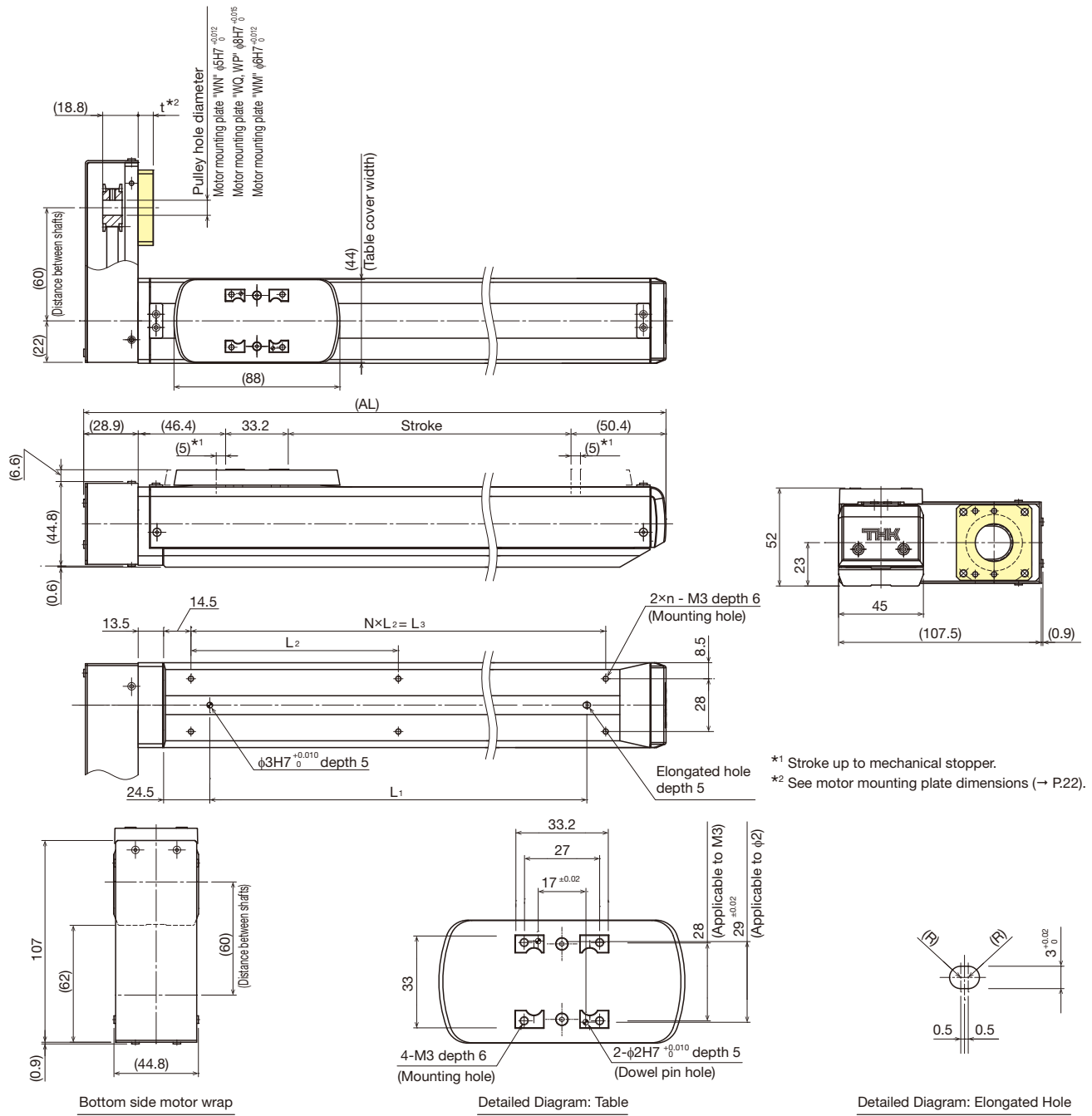

*1 Stroke up to mechanical stopper.
*2 See motor mounting plate dimensions (→ P.29).

Stroke [mm] (Stroke between mechanical stoppers)		50 (60)	100 (110)	150 (160)	200 (210)	250 (260)	300 (310)
Maximum speed ^{*3 *4} [mm/s]	Ball screw lead: 6mm	300					
Dimensions [mm]	AL	209	259	309	359	409	459
	L ₁	100	150	200	250	300	350
	L ₂	120	85	110	90	105	120
	L ₃	120	170	220	270	315	360
Mounting pitch count	N	1	2	2	3	3	3
Mounting hole count	n	2	3	3	4	4	4
Weight [kg]		1.2	1.4	1.6	1.8	2.0	2.2

*3 The maximum speed varies depending on the motor you use.

*4 The maximum speed is the value restricted by the permissible rotational speed of the ball screw.



KRF5 without motor

Model Configuration

Model	Ball screw lead	Stroke	Design symbol	With/without motor	Intermediate flange	Option
KRF5	06	0150	A	0	AN	GR-SB

KRF5	06: 6mm 10: 10mm	0050: 50mm to 0550: 550mm	A	0: Without motor 1: With motor (Prepared by THK)	A0: Without intermediate flange AN AQ AP AS AR	No symbol: Red cover GR: Gray cover SB: Slider base <input type="checkbox"/> 1 <input type="checkbox"/> 2: Sensor Note: If the GR is not included in the model configuration, cover will be red.
-------------	-----------------------------------	---	----------	---	---	---

Basic Specifications

LM guide portion	Basic dynamic load rating C [N]	7240	
	Basic Static Load Rating C ₀ [N]	12150	
Ball screw portion	Basic dynamic load rating C _a [N]	1950	1120
	Basic Static Load Rating C _{0a} [N]	3510	1740
	Screw shaft diameter [mm]	φ8	
	Ball screw lead [mm]	6	10
Bearing portion (Fixed side)	Axial direction	Basic dynamic load rating C _a [N]	2050
		Static Permissible Load P _{0a} [N]	1830
Permissible rotational speed *1 [min ⁻¹]		3000	
Starting torque *2 [N·m]		0.01	0.012
Positioning repeatability *3 [mm]		±0.010	
Lost motion *3 [mm]		0.1	
Permissible input torque [N·m]		0.671	
Static permissible moment *4 [N·m]		MA: 84 MB: 48.4 Mc: 105.8	

- *1 Dependent on the stroke.
- *2 The starting torque represents values when the standard grease is filled.
- *3 These represent values when measured using a motor provided by THK.
- *4 Applied point of moment load for MA and MC are the top face of the table, and that for MB is the center of the table.

Static permissible moment

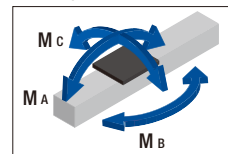

Reference Permissible Overhang Length*

Horizontal use

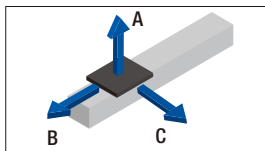

Wall use

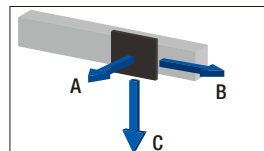

Vertical use

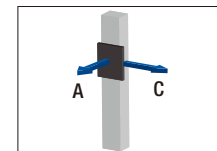

Horizontal mount

Ball screw lead [mm]	Load mass [kg]	A	B	C
6	9.5	350	50	150
	19	150	20	60
10	7.5	310	70	180
	15	130	20	60

Wall mount

Ball screw lead [mm]	Load mass [kg]	A	B	C
6	7	180	60	500
	14	60	20	130
10	6	170	70	390
	12.5	60	20	120

Vertical mount

Ball screw lead [mm]	Load mass [kg]	A	C
6	3	210	210
	6	90	90
10	1.5	390	390
	3.5	180	180

* This value is the overhang length whose running life is 10,000 km for horizontal mount and wall mount, and 5,000 km for vertical direction. A permissible value of the applied load in each direction.

KRF5

Dimensions

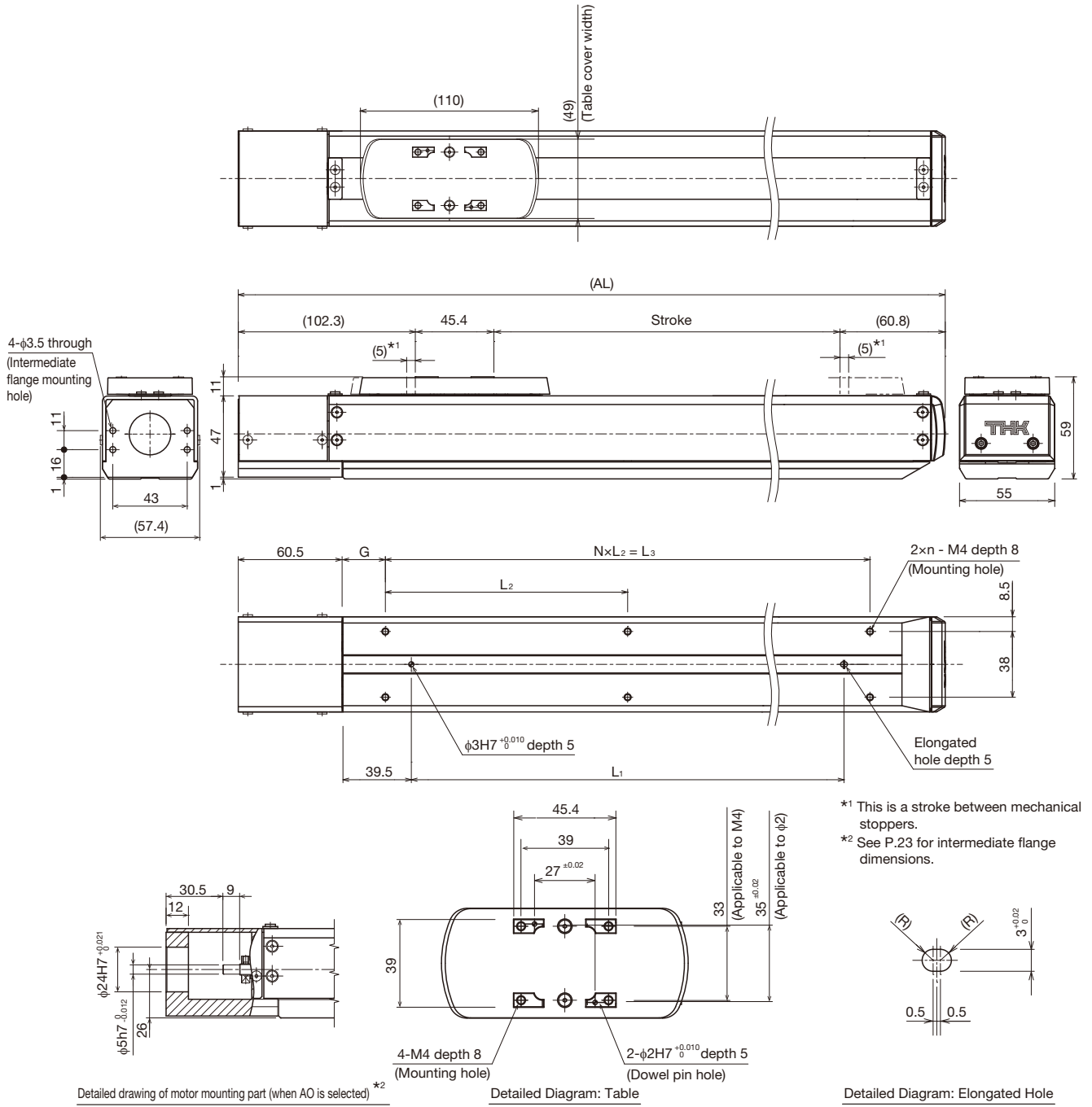

Stroke [mm] (Stroke between mechanical stoppers)	50 (60)	100 (110)	150 (160)	200 (210)	250 (260)	300 (310)	350 (360)	400 (410)	450 (460)	500 (510)	550 (560)	
Maximum speed ^{*3} ^{*4} [mm/s]	300										250	
	Ball screw lead: 6mm										430	
	Ball screw lead: 10mm										430	
Dimensions [mm]	AL	259	309	359	409	459	509	559	609	659	709	759
	L ₁	100	150	200	250	300	350	400	450	500	550	600
	L ₂	140	100	120	140	115	130	110	120	135	120	130
	L ₃	140	200	240	280	345	390	440	480	540	600	650
G	19.5	14.5	19.5	24.5	17	19.5	19.5	24.5	19.5	14.5	14.5	
Mounting pitch count	N	1	2	2	2	3	3	4	4	4	5	5
Mounting hole count	n	2	3	3	3	4	4	5	5	5	6	6
Weight [kg]	2.0	2.4	2.7	3.0	3.3	3.6	3.9	4.2	4.5	4.8	5.1	

^{*3} The maximum speed varies depending on the motor used.

^{*4} The maximum speed is the value restricted by the permissible rotational speed of the ball screw.



KRF5R without motor

Model Configuration

Model	Ball screw lead	Stroke	Design symbol	With/without motor	Intermediate flange	Motor shaft fixing method	Option
KRF5R	06	0150	A	1	WN	D	MR-GR

KRF5R	06: 6mm	0050: 50mm	A	0: Without motor 1: With motor (Prepared by THK)	WN	D: D-cut K: Key	MR: Motor right wrap
	10: 10mm	to 0550: 550mm					ML: Motor left wrap
							MD: Motor down wrap
							GR: Gray cover
							SB: Slider base
							<input type="checkbox"/> 1 <input type="checkbox"/> 2: Sensor

Basic Specifications

LM guide portion	Basic dynamic load rating C [N]		7240
	Basic Static Load Rating Co [N]		12150
Ball screw portion	Basic dynamic load rating Ca [N]		1950 1120
	Basic Static Load Rating Coa [N]		3510 1740
	Screw shaft diameter [mm]		φ8
	Ball screw lead [mm]		6 10
Bearing portion (Fixed side)	Axial direction	Basic dynamic load rating Ca [N]	2050
		Static Permissible Load Poa [N]	1830
Permissible rotational speed *1 [min ⁻¹]			3000
Starting torque *2 [N·m]			0.01 0.012
Positioning repeatability *3 [mm]			±0.010
Lost motion *3 [mm]			0.1
Permissible input torque [N·m]			0.671
Static permissible moment *4 [N·m]			MA: 84 MB: 48.4 MC: 105.8

- *1 Dependent on the stroke.
- *2 The starting torque represents values when the standard grease is filled.
- *3 These represent values when measured using a motor provided by THK.
- *4 Applied point of moment load for MA and MC are the top face of the table, and that for MB is the center of the table.

Static permissible moment

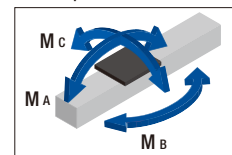

Reference Permissible Overhang Length*

Horizontal use

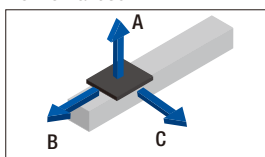

Wall use

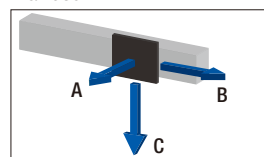

Vertical use

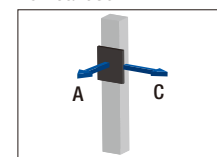

Horizontal mount [mm]

Ball screw lead [mm]	Load mass [kg]	A	B	C
6	9.5	350	50	150
	19	150	20	60
10	7.5	310	70	180
	15	130	20	60

Wall mount [mm]

Ball screw lead [mm]	Load mass [kg]	A	B	C
6	7	180	60	500
	14	60	20	130
10	6	170	70	390
	12.5	60	20	120

Vertical mount [mm]

Ball screw lead [mm]	Load mass [kg]	A	C
6	3	210	210
	6	90	90
10	1.5	390	390
	3.5	180	180

* This value is the overhang length whose running life is 10,000 km for horizontal mount and wall mount, and 5,000 km for vertical direction. A permissible value of the applied load in each direction.

KRF5R

Dimensions

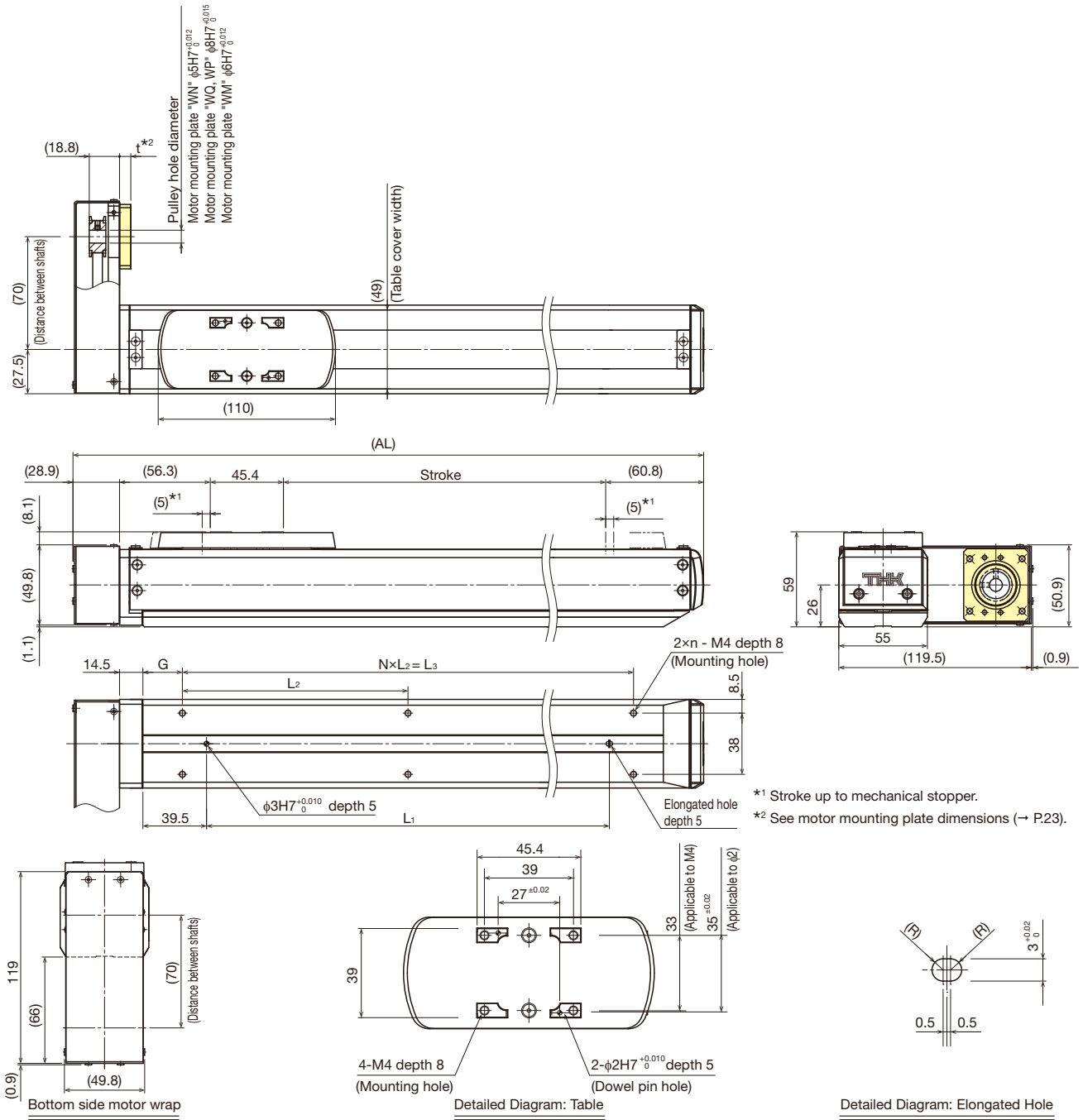

*1 Stroke up to mechanical stopper.
*2 See motor mounting plate dimensions (→ P.23).

Stroke [mm]		50	100	150	200	250	300	350	400	450	500	550
(Stroke between mechanical stoppers)		(60)	(110)	(160)	(210)	(260)	(310)	(360)	(410)	(460)	(510)	(560)
Maximum speed ^{*3 *4} [mm/s]	Ball screw lead: 6mm	300										250
	Ball screw lead: 10mm	500										430
Dimensions [mm]	AL	241.5	291.5	341.5	391.5	441.5	491.5	541.5	591.5	641.5	691.5	741.5
	L ₁	100	150	200	250	300	350	400	450	500	550	600
	L ₂	140	100	120	140	115	130	110	120	135	120	130
	L ₃	140	200	240	280	345	390	440	480	540	600	650
	G	19.5	14.5	19.5	24.5	17	19.5	19.5	24.5	19.5	14.5	14.5
Mounting pitch count	N	1	2	2	2	3	3	4	4	4	5	5
Mounting hole count	n	2	3	3	3	4	4	5	5	5	6	6
Weight [kg]		2.1	2.4	2.7	3.0	3.3	3.6	3.9	4.2	4.6	4.9	5.2

*3 The maximum speed varies depending on the motor you use.

*4 The maximum speed is the value restricted by the permissible rotational speed of the ball screw.

KRF6 without motor

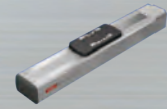

Model Configuration

Model	Ball screw lead	Stroke	Design symbol	With/without motor	Intermediate flange	Option
KRF6	06	0150	A	0	AQ	GR-SB

KRF6	06: 6mm	0050: 50mm	A	0: Without motor	A0: Without intermediate flange	No symbol: Red cover
	10: 10mm	to				GR: Gray cover
		0800: 800mm		1: With motor (Prepared by THK)	AQ	SB: Slider base
					AP	<input type="checkbox"/> 1 <input type="checkbox"/> 2: Sensor
					AR	Note: If the GR is not included in the model configuration, cover will be red.
					AU	
					AT	

Basic Specifications

LM guide portion	Basic dynamic load rating C [N]	11600	
	Basic Static Load Rating Co [N]	20200	
Ball screw portion	Basic dynamic load rating Ca [N]	2840	1760
	Basic Static Load Rating Coa [N]	4900	2840
	Screw shaft diameter [mm]	φ10	
Bearing portion (Fixed side)	Ball screw lead [mm]	6	10
	Axial direction	Basic dynamic load rating Ca [N]	2930
		Static Permissible Load Poa [N]	2150
Permissible rotational speed *1 [min ⁻¹]		3000	
Starting torque *2 [N·m]		0.014	0.02
Positioning repeatability *3 [mm]		±0.010	
Lost motion *3 [mm]		0.1	
Permissible input torque [N·m]		1.035	
Static permissible moment *4 [N·m]		MA: 166 MB: 103.8 MC: 179.5	

*1 Dependent on the stroke.

*2 The starting torque represents values when the standard grease is filled.

*3 These represent values when measured using a motor provided by THK.

*4 Applied point of moment load for MA and MC are the top face of the table, and that for MB is the center of the table.

Static permissible moment

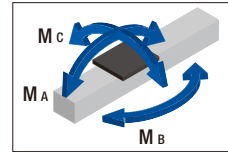

Reference Permissible Overhang Length*

Horizontal use

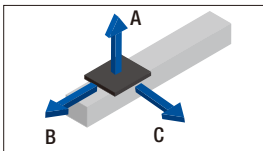

Wall use

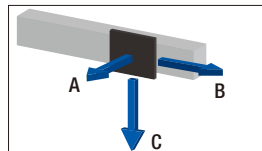

Vertical use

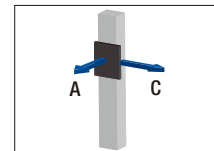

Horizontal mount

[mm]

Ball screw lead [mm]	Load mass [kg]	A	B	C
6	17.5	390	50	160
	35	170	10	60
10	15	320	60	170
	30	130	10	50

Wall mount

[mm]

Ball screw lead [mm]	Load mass [kg]	A	B	C
6	12	200	70	600
	24	70	20	140
10	11	200	80	460
	22	70	30	120

Vertical mount

[mm]

Ball screw lead [mm]	Load mass [kg]	A	C
6	5	240	240
	10	100	100
10	2.5	510	510
	5	230	230

* This value is the overhang length whose running life is 10,000 km for horizontal mount and wall mount, and 5,000 km for vertical direction. A permissible value of the applied load in each direction.

Dimensions

Stroke [mm] (Stroke between mechanical stoppers)	50 (70)	100 (120)	150 (170)	200 (220)	250 (270)	300 (320)	350 (370)	400 (420)	
Maximum speed *3 *4 [mm/s]	Ball screw lead: 6mm		300						
	Ball screw lead: 10mm		500						
Dimensions [mm]	AL	277.5	327.5	377.5	427.5	477.5	527.5	577.5	627.5
	L1	100	150	200	200	250	250	300	350
	L2	100	200	200	200	200	200	200	200
	L3	100	200	200	200	200	400	400	400
	L4	-	-	-	-	100	-	-	-
	G	50	25	50	75	50	25	50	75
H	50	50	50	75	75	100	100	100	
Mounting pitch count	N	1	1	1	1	2	2	2	
Mounting hole count	n	2	2	2	2	3	3	3	
Weight [kg]	2.7	3.1	3.5	3.9	4.3	4.8	5.2	5.6	

*3 The maximum speed varies depending on the motor used.

*4 The maximum speed is the value restricted by the permissible rotational speed of the ball screw.

KRF6

Dimensions

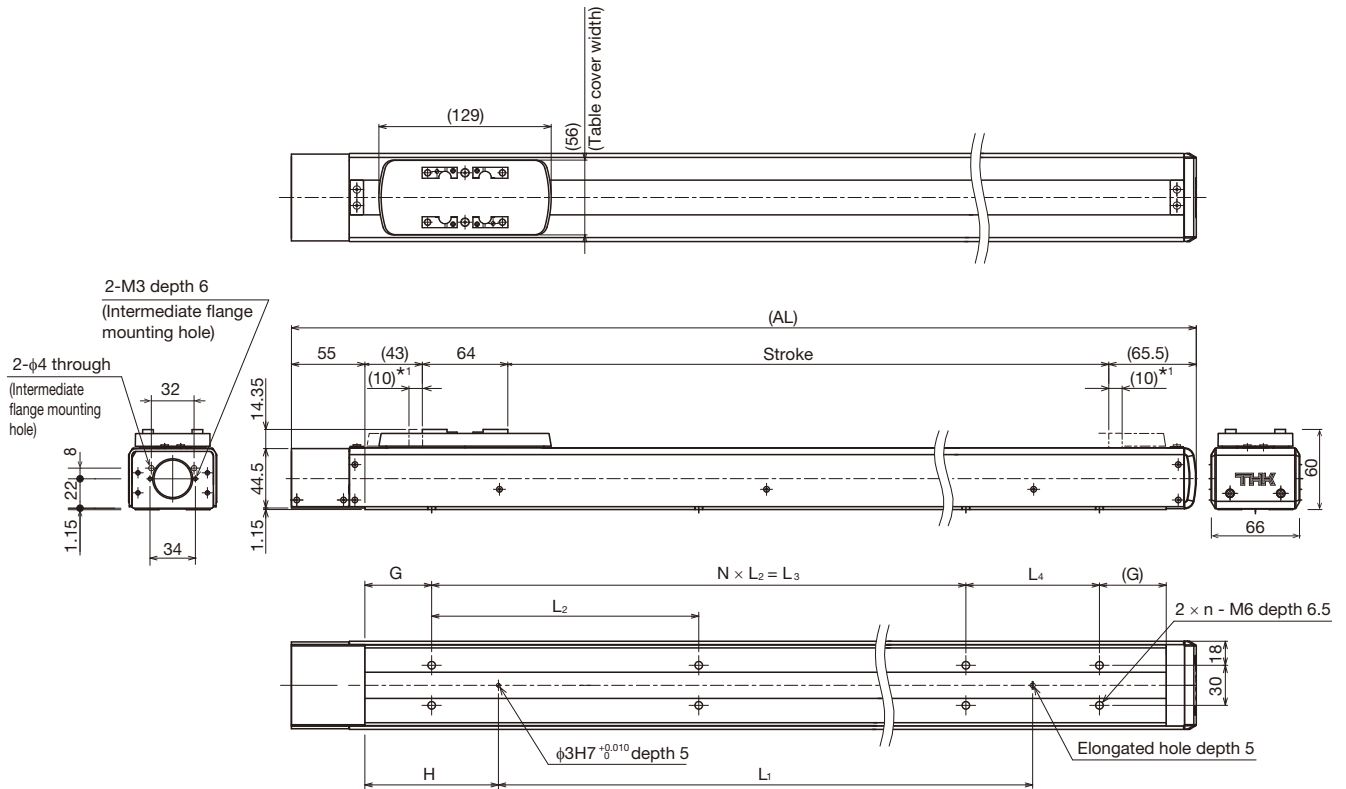

*1 This is a stroke between mechanical stoppers.
 *2 See P.24 for intermediate flange dimensions.

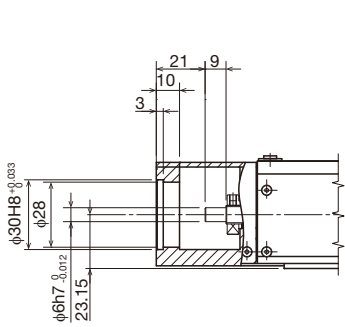

Detailed drawing of motor mounting part (when A0 is selected) *2

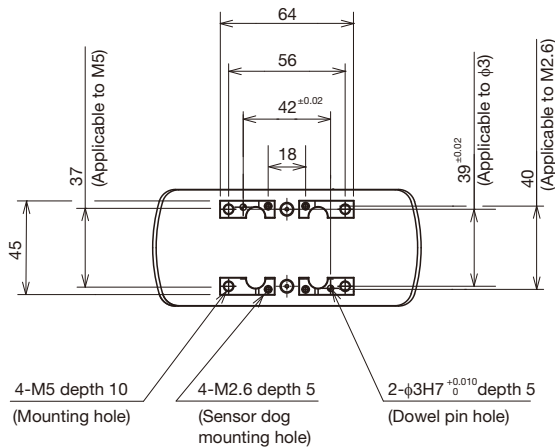

Detailed Diagram: Table

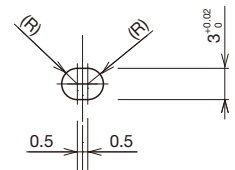

Detailed Diagram: Elongated Hole

Stroke [mm] (Stroke between mechanical stoppers)		450 (470)	500 (520)	550 (570)	600 (620)	650 (670)	700 (720)	750 (770)	800 (820)
Maximum speed [mm/s]	Ball screw lead: 6mm		300		260	220	200	170	150
	Ball screw lead: 10mm		500		440	380	330	290	260
Dimensions [mm]	AL	677.5	727.5	777.5	827.5	877.5	927.5	977.5	1027.5
	L ₁	400	450	500	550	600	650	700	750
	L ₂	200	200	200	200	200	200	200	200
	L ₃	400	600	600	600	600	800	800	800
	L ₄	100	-	-	-	100	-	-	-
	G	50	25	50	75	50	25	50	75
	H	100	100	100	100	100	100	100	100
Mounting pitch count	N	2	3	3	3	3	4	4	4
Mounting hole count	n	4	4	4	4	5	5	5	5
Weight [kg]		6.0	6.4	6.8	7.2	7.6	8.0	8.4	8.8

*3 The maximum speed varies depending on the motor used.

*4 The maximum speed is the value restricted by the permissible rotational speed of the ball screw.

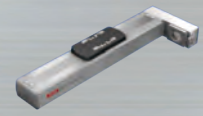

KRF6R without motor

Model Configuration

Model	Ball screw lead	Stroke	Design symbol	With/without motor	Intermediate flange	Motor shaft fixing method	Option
KRF6R	- 06 -	0150	A	- 1 -	- WQ -	D	MR-GR

KRF6R	06: 6mm	0050: 50mm	A	0: Without motor	WP	D: D-cut	MR: Motor right wrap
	10: 10mm	to		1: With motor (Prepared by THK)	WQ	K: Key	ML: Motor left wrap
		0800: 800mm				M: Friction tightening	MD: Motor down wrap
							GR: Gray cover
							SB: Slider base
							<input type="checkbox"/> 1 <input type="checkbox"/> 2: Sensor

Basic Specifications

LM guide portion	Basic dynamic load rating C [N]	11600	
	Basic Static Load Rating Co [N]	20200	
Ball screw portion	Basic dynamic load rating Ca [N]	2840	1760
	Basic Static Load Rating Coa [N]	4900	2840
	Screw shaft diameter [mm]	φ10	
	Ball screw lead [mm]	6	10
	Bearing portion (Fixed side)	Axial direction	Basic dynamic load rating Ca [N]
Static Permissible Load Poa [N]			2150
Permissible rotational speed *1 [min ⁻¹]		3000	
Starting torque *2 [N·m]		0.014	0.02
Positioning repeatability *3 [mm]		±0.010	
Lost motion *3 [mm]		0.1	
Permissible input torque [N·m]		1.035	
Static permissible moment *4 [N·m]		MA: 166 MB: 103.8 MC: 179.5	

*1 Dependent on the stroke.

*2 The starting torque represents values when the standard grease is filled.

*3 These represent values when measured using a motor provided by THK.

*4 Applied point of moment load for MA and MC are the top face of the table, and that for MB is the center of the table.

Static permissible moment

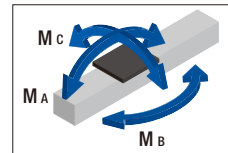

Reference Permissible Overhang Length*

Horizontal use

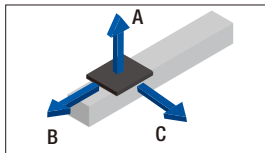

Ball screw lead [mm]	Load mass [kg]	A	B	C
6	17.5	390	50	160
	35	170	10	60
10	15	320	60	170
	30	130	10	50

Wall use

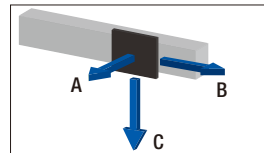

Ball screw lead [mm]	Load mass [kg]	A	B	C
6	12	200	70	600
	24	70	20	140
10	11	200	80	460
	22	70	30	120

Vertical use

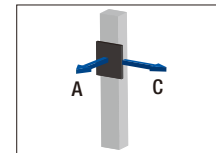

Ball screw lead [mm]	Load mass [kg]	A	C
6	5	240	240
	10	100	100
10	2.5	510	510
	5	230	230

* This value is the overhang length whose running life is 10,000 km for horizontal mount and wall mount, and 5,000 km for vertical direction. A permissible value of the applied load in each direction.

Dimensions

Stroke [mm] (Stroke between mechanical stoppers)	50 (70)	100 (120)	150 (170)	200 (220)	250 (270)	300 (320)	350 (370)	400 (420)	
Maximum speed *2 *3 [mm/s]	Ball screw lead: 6mm	300							
	Ball screw lead: 10mm	500							
Dimensions [mm]	AL	276	326	376	426	476	526	576	626
	L1	100	150	200	200	250	250	300	350
	L2	100	200	200	200	200	200	200	200
	L3	100	200	200	200	200	400	400	400
	L4	-	-	-	-	100	-	-	-
	G	50	25	50	75	50	25	50	75
H	50	50	50	75	75	100	100	100	
Mounting pitch count	N	1	1	1	1	1	2	2	2
Mounting hole count	n	2	2	2	2	3	3	3	3
Weight [kg]	3.5	3.9	4.3	4.7	5.1	5.5	5.9	6.3	

*2 The maximum speed varies depending on the motor used.

*3 The maximum speed is the value restricted by the permissible rotational speed of the ball screw.

KRF6R

Dimensions

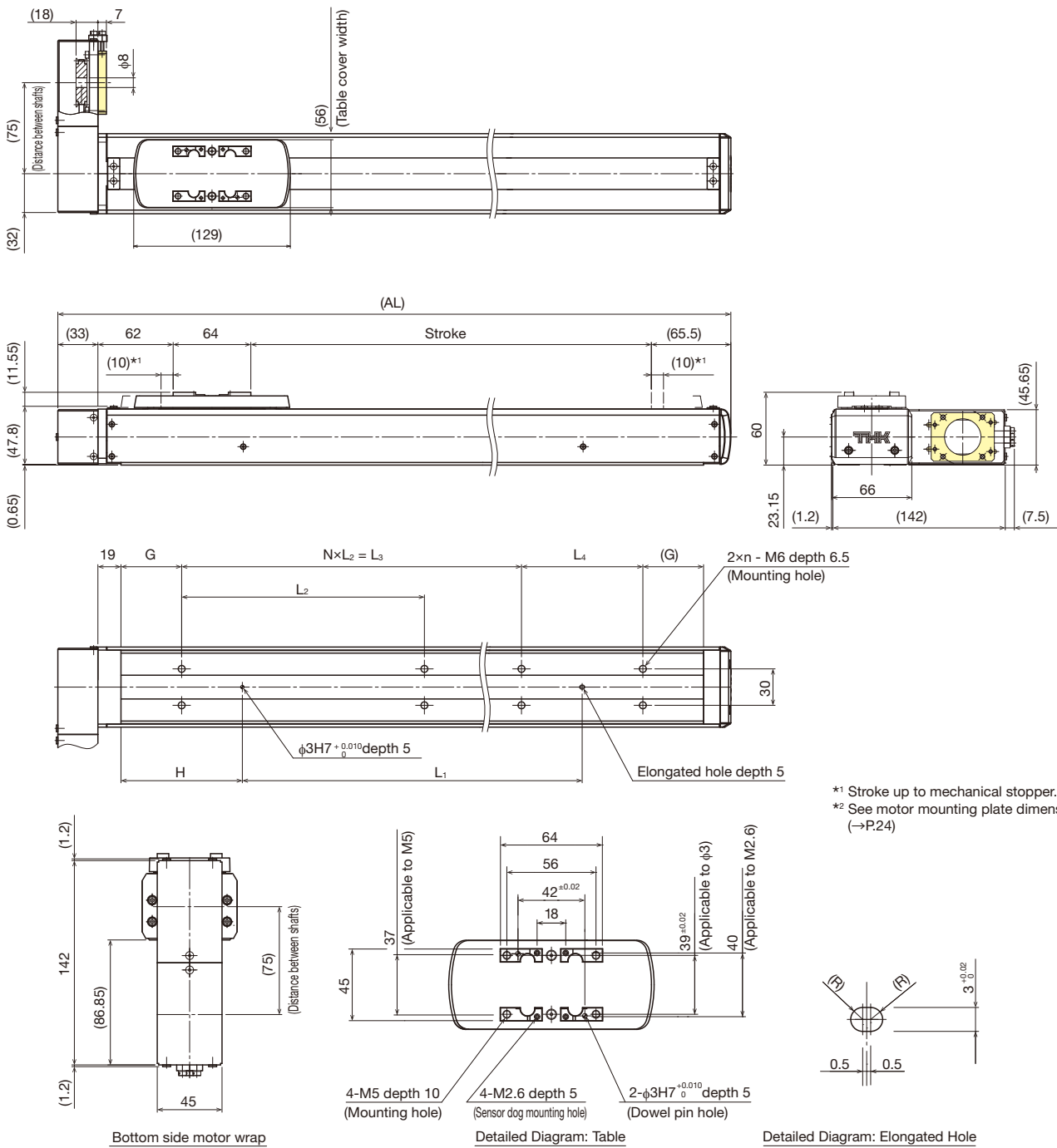

*1 Stroke up to mechanical stopper.
 *2 See motor mounting plate dimensions (→P.24)

Stroke [mm] (Stroke between mechanical stoppers)		450 (470)	500 (520)	550 (570)	600 (620)	650 (670)	700 (720)	750 (770)	800 (820)
Maximum speed *2 *3 [mm/s]	Ball screw lead: 6mm		300		260	220	200	170	150
	Ball screw lead: 10mm		500		440	380	330	290	260
Dimensions [mm]	AL	676	726	776	826	876	926	976	1026
	L1	400	450	500	550	600	650	700	750
	L2	200	200	200	200	200	200	200	200
	L3	400	600	600	600	600	800	800	800
	L4	100	-	-	-	100	-	-	-
	G	50	25	50	75	50	25	50	75
Mounting pitch count	H	100	100	100	100	100	100	100	100
Mounting hole count	N	2	3	3	3	3	4	4	4
	n	4	4	4	4	5	5	5	5
Weight [kg]		6.7	7.1	7.5	7.9	8.3	8.7	9.1	9.5

*2 The maximum speed varies depending on the motor you use.
 *3 The maximum speed is the value restricted by the permissible rotational speed of the ball screw.

Options

SB: Slider base

THK provides slider bases for installing the KRF main unit from the top face.

* The product is shipped with this optional assembled.

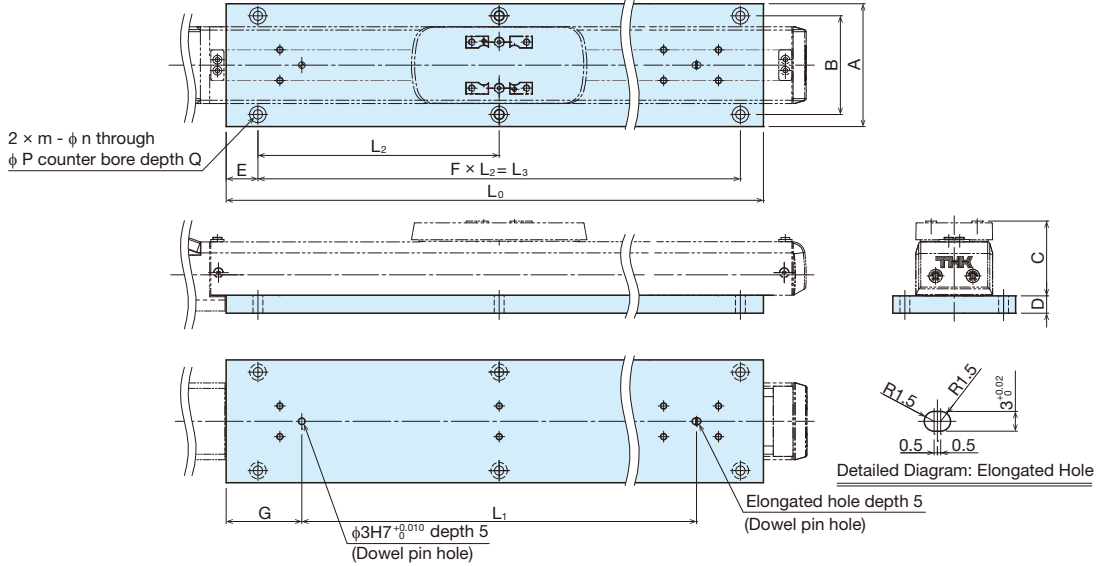

Unit: mm

Model	A	B	C	D
KRF4 / KRF4R	70	55	42.1	9.9
KRF5 / KRF5R	80	65	49.1	9.9
KRF6 / KRF6R	90	78	60	10

Note) When the slider base is mounted on KRF6, the height of KRF6 will be 10mm higher than the standard product due to the thickness of slider base.

Stroke		50	100	150	200	250	300	350	400	450	500	550	600	650	700	750	800
KRF4 KRF4R	L ₀	142	192	242	292	342	392	-	-	-	-	-	-	-	-	-	-
	L ₁	100	150	200	250	300	350	-	-	-	-	-	-	-	-	-	-
	L ₂	120	85	110	90	105	120	-	-	-	-	-	-	-	-	-	-
	L ₃	120	170	220	270	315	360	-	-	-	-	-	-	-	-	-	-
	E	14.5						-	-	-	-	-	-	-	-	-	-
	F	1	2	2	3	3	3	-	-	-	-	-	-	-	-	-	-
	G	24.5						-	-	-	-	-	-	-	-	-	-
	m	2	3	3	4	4	4	-	-	-	-	-	-	-	-	-	-
	n	4.5						-	-	-	-	-	-	-	-	-	-
	P	8						-	-	-	-	-	-	-	-	-	-
KRF5 KRF5R	Q	4.4						-	-	-	-	-	-	-	-	-	-
	L ₀	180	230	280	330	380	430	480	530	580	630	680	-	-	-	-	-
	L ₁	100	150	200	250	300	350	400	450	500	550	600	-	-	-	-	-
	L ₂	140	100	120	140	115	130	110	120	135	120	130	-	-	-	-	-
	L ₃	140	200	240	280	345	390	440	480	540	600	650	-	-	-	-	-
	E	19.5	15	19.5	24.5	17	19.5	19.5	24.5	19.5	14.5	14.5	-	-	-	-	-
	F	1	2	2	2	3	3	4	4	4	5	5	-	-	-	-	-
	G	39.5						-	-	-	-	-	-	-	-	-	
	m	2	3	3	3	4	4	5	5	5	6	6	-	-	-	-	-
	n	4.5						-	-	-	-	-	-	-	-	-	
KRF6 KRF6R	P	8						-	-	-	-	-	-	-	-	-	
	Q	4.4						-	-	-	-	-	-	-	-	-	
	L ₀	200	250	300	350	400	450	500	550	600	650	700	750	800	850	900	950
	L ₁	100	150	200	200	250	250	300	350	400	450	500	550	600	650	700	750
	L ₂	100	200	130	150	170	140	150	160	170	140	160	170	180	150	170	180
	L ₃	100	200	260	300	340	420	450	480	510	560	640	680	720	750	850	900
	E	50	25	20	25	30	15	25	35	45	45	30	35	40	50	25	25
	F	1	1	2	2	2	3	3	3	3	4	4	4	4	5	5	5
	G	50	50	50	75	75	100	100	100	100	100	100	100	100	100	100	100
	m	2	2	3	3	3	4	4	4	4	5	5	5	5	6	6	6
n							5.5										
P							9.5										
Q							5.4										

□1□2: Sensors

Optional proximity sensors and photo sensors are available for KRF. Models equipped with a sensor are also provided with a dedicated sensor rail. Please use the sensor with the following precautions (Notes 1 to 6) in mind.

- Note 1) The customer should provide a sensor dog since it cannot be installed onto the actuator main unit. (Excluding KRF6)
- Note 2) Sensor dog for KRF6 to be shipped loose.
- Note 3) Sensor rails are pre-mounted, and sensors are provided with the product.
- Note 4) When optional sensor is used, note the home position may differ from the position indicated by the dimension in this catalog, in considering using them.
- Note 5) Proximity sensors placed too close to each other may not work properly. In such a case, the customer should provide a different frequency type of sensor.
(For specifications, contact each manufacturer.)
- Note 6) Mount the sensor/sensor rail on both sides if the stroke is not more than 100 mm.

Description	Model	Accessory	Symbol	
			□1	□2
With sensor rail	-	-	L/R	1
Photo sensor * [x 3]	EE-SX674 (OMRON Corporation)	Mounting screw, nuts, sensor rail (x 1 or 2), mounting plates (x 3), connectors (EE-1001, x 3)	L/R	6
Sensor N.O. contact [x 1] N.C. contact [x 2]	GX-F12A (Panasonic Industrial Devices SUNX Co., Ltd.) GX-F12B (Panasonic Industrial Devices SUNX Co., Ltd.)	Mounting screw, nuts, sensor rail (x 1 or 2)	L/R	J
Sensor N.O. contact [x 1] (PNP output) N.C. contact [x 2] (PNP output)	GX-F12A-P (Panasonic Industrial Devices SUNX Co., Ltd.) GX-F12B-P (Panasonic Industrial Devices SUNX Co., Ltd.)	Mounting screw, nuts, sensor rail (x 1 or 2)	L/R	M

N.O. contact: Normally open contact point

N.C. contact: Normally closed contact point

Sensors marked with a symbol "M", if combined with our controller, cannot be used as a home position sensor.

* The photo sensors can be switched between ON when lit and ON when unlit.

The range of interference with the motor

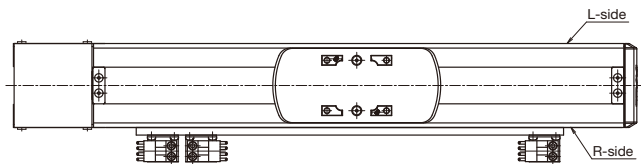
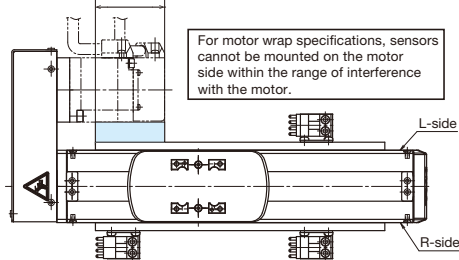

Option: Sensor symbol

Symbol	
□1	□2
R	6

* Symbol □1 represents the mounting position for sensor rail and sensor. No symbol is given for the case of stroke 100mm or shorter.

Symbol □2 represents the types of sensors.

Symbol 1: Sensor rail

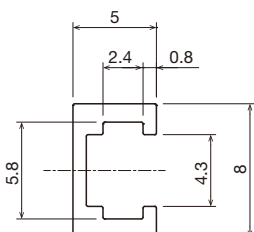
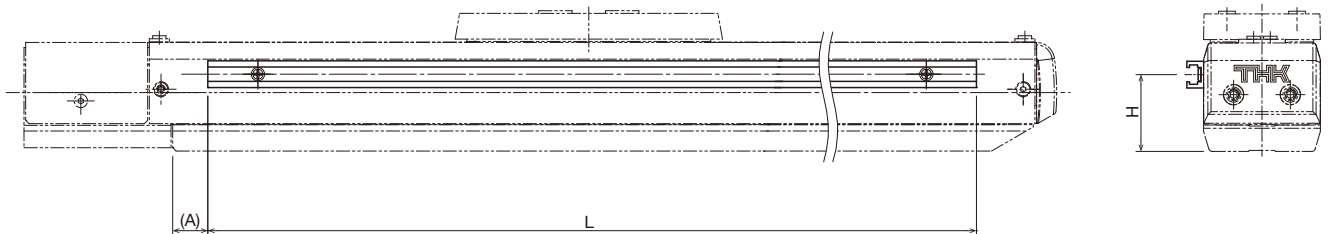

Unit: mm

Model	H	(A)	L
KRF4 / KRF4R	32.5	10.5	Stroke +80
KRF5 / KRF5R	37.5	26	
KRF6 / KRF6R	33.7	35	

Symbols J, M: Proximity sensor GX-F12* (Panasonic Industrial Devices SUNX Co., Ltd.)

KRF4/4R/5/5R

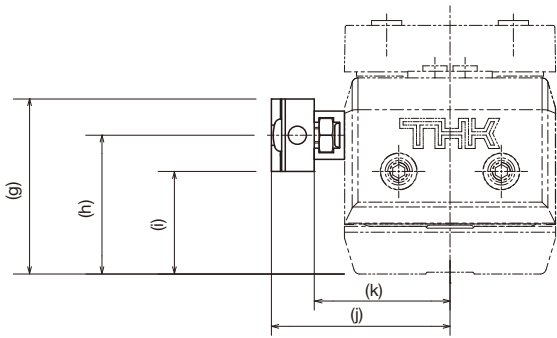

KRF6/6R

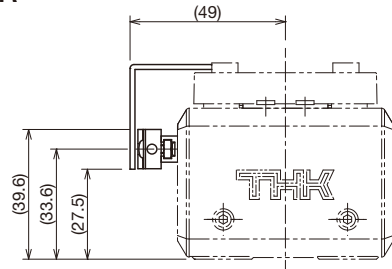

Sensor dog width: 26mm

Unit: mm

Model	g	h	i	j	k
KRF4 / KRF4R	38.5	32.5	26.5	34.6	27.5
KRF5 / KRF5R	43.5	37.5	31.5	39.6	32.5

Symbol 6: Photo sensor EE-SX674 (OMRON Corporation)

KRF4/4R/5/5R

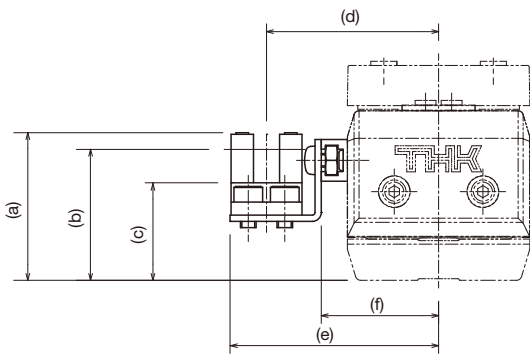

KRF6/6R

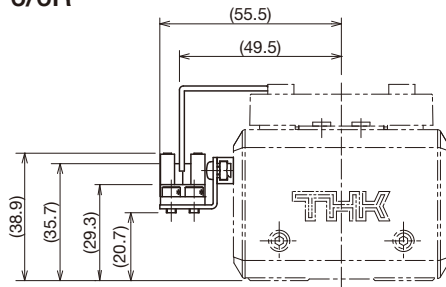

Sensor dog width: 26mm

Unit: mm

Model	a	b	c	d	e	f
KRF4 / KRF4R	37.8	34.6	28.2	38	45	27.5
KRF5 / KRF5R	42.8	39.6	33.2	43	50	32.5

GR: Change the cover color to gray

As an option for KRF, the cover color can be changed from red to gray.



If the GR is not included in the model configuration, cover will be red.

Intermediate flange

Intermediate flanges are available to mount various kinds of motors.

If choosing "0" or "1" as with/without motor for model of type without motor, specify an intermediate flange that matches the motor used.

Table: Table of Motors Used and Corresponding Intermediate Flanges

	Motor type		Rated output	Flange angle	KRF4	KRF5	KRF6		
AC servo motor	Yaskawa Electric Corporation	Σ-Vmini	SGMMV-A1	10W	□25	AN	AN	-	
			SGMMV-A2	20W		AN	AN	-	
			SGMMV-A3	30W		AN	AN	-	
		Σ-V	50W	SGMJV-A5	□40	AQ	AQ	AQ	
				SGMAV-A5		AQ	AQ	AQ	
				SGMJV-01		-	-	AQ	
			100W	SGMAV-01	-	-	AQ		
				SGMJV-C2	150W	-	-	AQ	
				SGM7J-A5	50W	AQ	AQ	AQ	
		Σ-7	50W	SGM7A-A5	□40	AQ	AQ	AQ	
				SGM7J-01		-	-	AQ	
			100W	SGM7A-01		-	-	AQ	
	SGM7J-C2			150W		-	-	AQ	
	Mitsubishi Electric Corporation	J3	50W	□40	AQ	AQ	AQ		
					HF-MP053	AQ	AQ	AQ	
			100W		HF-KP13	-	-	AQ	
					HF-KP13	-	-	AQ	
		J4	10W	□25	HG-AK0136	AN	AN	-	
					20W	HG-AK0236	AN	AN	-
					30W	HG-AK0336	AN	AN	-
			50W		□40	HG-MR053	AQ	AQ	AQ
						HG-KR053	AQ	AQ	AQ
						HG-MR13	-	-	AQ
		100W	HG-KR13	-	-	AQ			
			50W	□40	HF-KN053	AQ	AQ	AQ	
	100W	HF-KN13			-	-	AQ		
	JN	50W	□40	TS4602	AQ	AQ	AQ		
				100W	TS4603	-	-	AQ	
				150W	TS4604	-	-	AQ	
		30W		□40	TSM3101	AQ	AQ	AQ	
					50W	TSM3102	AQ	AQ	AQ
					100W	TSM3104	-	-	AQ
	Panasonic Corporation	MINAS A5	50W	□38	MSMD5A	AP	AP	AP	
					MSME5A	AP	AP	AP	
			100W		MSMD01	-	-	AP	
					MSME01	-	-	AP	
		MINAS A6	50W	□38	MSMF5A	AP	AP	AP	
					MHMF5A	□40	AQ	AQ	AQ
			100W		MSMF01	□38	-	-	AP
					MHMF01	□40	-	-	AQ
Keyence Corporation		SV	SV-M005	□40	AQ	AQ	AQ		
			SV-M010	100W	-	-	AQ		
		SV2	SV2-M005	□40	AQ	AQ	AQ		
			SV2-M010	100W	-	-	AQ		
Sanyo Denki Co., Ltd.	SANMOTION R	R2□A04003	□40	AQ	AQ	AQ			
		R2□A04005	50W	AQ	AQ	AQ			
		R2□A04010	100W	-	-	AQ			
OMRON Corporation	OMNUC G5	R88M-K05030	□40	AQ	AQ	AQ			
		R88M-K10030	100W	-	-	AQ			
Fanuc Corporation	β is series	βis0.2/5000	□40	AQ	AQ	AQ			
		βis0.3/5000	100W	-	-	AQ			
Stepper motor	Oriental Motor Co. Ltd.	α step	AZ2*, AR2*	□28	AS	AS	-		
			AZ4*, AR4*	□42	AR	AR	AR		
			AZ6*, AR6*	□60	-	-	AU		
			CRK	CRK52*	□28	AS	AS	-	
				CRK54*	□42	AR	AR	AR	
				CRK56*	□60	-	-	AU	
		RK II	RKS54*	□42	AR	AR	AR		
			RKS56*	□60	-	-	AU		
			PKA544	□42	AR	AR	AR		
		PKA	PKA566	□60	-	-	AU		
			CVK52*	□28	AS	AS	-		
			CVK54*	□42	AR	AR	AR		
		CVK	CVK56*	□60	-	-	AU		
			CMK22*	□28	AS	AS	-		
			CMK24*	□42	AR	AR	AR		
			CMK26*	□56.4	-	-	AT		
			CVK22*	□28	AS	AS	-		
			CVK24*	□42	AR	AR	AR		
	Sanyo Denki Co., Ltd.	PB	PBDM28*	□28	AS	AS	-		
			PBDM423, PBA**423	□42	AR	AR	AR		
			PBDM60*, PBA**60*	□60	-	-	AU		
			FAF/DF52*	□28	AS	AS	-		
			FAF/DF/FSF55*	□42	AR	AR	AR		
			FAF/DF/FSF78*	□60	-	-	AU		
		5-phase	D*14S28*	□28	AS	AS	-		
			D*15H52*	□42	AR	AR	AR		
			D*16H71*	□56.4	-	-	AT		
			DB16H78*	□60	-	-	AU		
			QS-M28	□28	AS	AS	-		
			QS-M42	□42	AR	AR	AR		
	Keyence Corporation	2-phase	QS-M60	□60	-	-	AU		

Note 1) The symbols in the table indicate the housing A and intermediate flange.

Note 2) For motor coupling, contact THK.

Note 3) Motor model number in the table shows the main part of the model number only. For more details, please refer to catalogs from each motor manufacturers.

Note 4) If the motor's maximum torque mounted exceeds the permissible input torque (refer to P.5, 7, 9, 11, 13, 15), take safety measures, such as torque restrictions.

Motor mounting plate for motor wrap

Motor wrap symbol configuration

Motor mounting plates are available to mount various kinds of motors. Specify the motor wrap symbol corresponding to the motor used.

$$\frac{WQ}{(1)} - \frac{M}{(2)}$$

(1) Motor mounting plate type

Refer to the table below "Motor wrap symbols corresponding to motors used".

(2) Motor shaft fixing method

K: Key
D: D-cut
M: Friction tightening

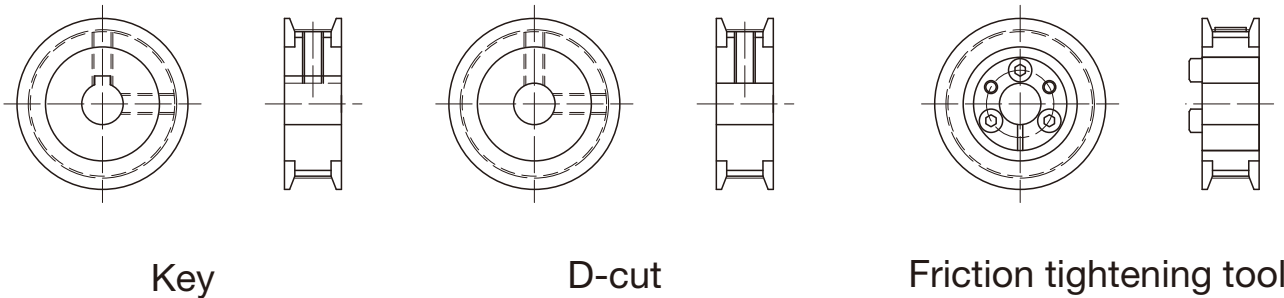

Figure: Motor shaft fixing method

Table: Motor wrap symbols corresponding to motors used

AC servo motor	Motor type		Rated output	Flange angle	KRF4	KRF5	KRF6		
	Motor type	Model							
Yaskawa Electric Corporation	Σ-Vmini	SGMMV-A1	10W	□25	WN-D	WN-D	-		
		SGMMV-A2	20W		WN-D	WN-D	-		
		SGMMV-A3	30W		WN-D	WN-D	-		
		SGMJV-A5	50W		WQ-K	WQ-K	WQ-K,WQ-M		
		SGMAV-A5			WQ-K	WQ-K	WQ-K,WQ-M		
		SGMJV-01			-	-	WQ-K,WQ-M		
	Σ-V	SGMAV-01	100W	□40	-	-	WQ-K,WQ-M		
		SGMJV-C2	150W		-	-	WQ-K,WQ-M		
		SGM7J-A5	50W		WQ-K	WQ-K	WQ-K,WQ-M		
		SGM7A-A5			WQ-K	WQ-K	WQ-K,WQ-M		
		SGM7J-01			-	-	WQ-K,WQ-M		
		Σ-7	SGM7A-01		100W	□40	-	-	WQ-K,WQ-M
	SGM7J-C2		150W	-	-		WQ-K,WQ-M		
	HF-MP053		50W	WQ-D	WQ-D		WQ-D,WQ-M		
	HF-KP053			WQ-D	WQ-D		WQ-D,WQ-M		
	HF-KP13			100W	-		-	WQ-D,WQ-M	
	Mitsubishi Electric Corporation		J3	HG-AK0136	10W		□25	WN-D	WN-D
		HG-AK0236		20W	WN-D	WN-D		-	
		HG-AK0336		30W	WN-D	WN-D		-	
		J4	HG-MR053	50W	□40	WQ-D	WQ-D	WQ-D,WQ-M	
			HG-KR053			WQ-D	WQ-D	WQ-D,WQ-M	
			HG-MR13	100W		-	-	WQ-D,WQ-M	
			HG-KR13			-	-	WQ-D,WQ-M	
		JN	HF-KN053	50W	□40	WQ-D	WQ-D	WQ-D,WQ-M	
			HF-KN13	100W		-	-	WQ-D,WQ-M	
			TS4602	50W		WQ-D	WQ-D	WQ-D,WQ-M	
		Tamagawa Seiki Co., Ltd.	TBL-II	TS4603	100W	□40	-	-	WQ-D,WQ-M
				TS4604	150W		-	-	WQ-D,WQ-M
	TSM3101			30W	WQ-D		WQ-D	WQ-D,WQ-M	
	TBL-IV		TSM3102	50W	WQ-D		WQ-D	WQ-D,WQ-M	
TSM3104			100W	-	-		WQ-D,WQ-M		
MSMD5A			50W	□38	WP-K		WP-K	WP-K,WP-M	
MSME5A	WP-K	WP-K			WP-K,WP-M				
MSMD01	100W	-			-	WP-K,WP-M			
Panasonic Corporation	MINAS A5	MSME01	50W	□38	-	-	WP-K,WP-M		
		MSMF5A			WP-K	WP-K	WP-K,WP-M		
		MHMF5A			50W	WQ-K	WQ-K	WP-K,WP-M	
	MINAS A6	MSMF01	100W	□38	-	-	WP-K,WP-M		
		MHMF01			□40	-	-	WP-K,WP-M	
		SV			SV-M005	50W	□40	WQ-K	WQ-K
SV2	SV-M010	100W	-	-	WQ-K,WQ-M				
	SV2-M005	50W	WQ-K	WQ-K	WQ-K,WQ-M				
Keyence Corporation	SV2	SV2-M010	100W	-	-	WQ-K,WQ-M			
		R88M-K05030	50W	□40	WQ-K	WQ-K	WQ-K,WQ-M		
		R88M-K10030	100W		-	-	WQ-K,WQ-M		
OMRON Corporation	OMNUC G5	R2AA04005	50W		□40	-	-	WQ-M	
		R2AA04010	100W	-		-	WQ-M		
		Sanyo Denki Co., Ltd.	SANMOTION R						

Note) Motor model number in the table shows the main part of the model number only. For more details, please refer to catalogs from each motor manufacturers.

For KRF4

Intermediate flange

KRF4
AP

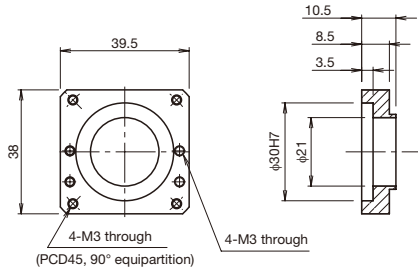

KRF4
AQ

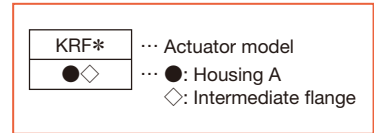
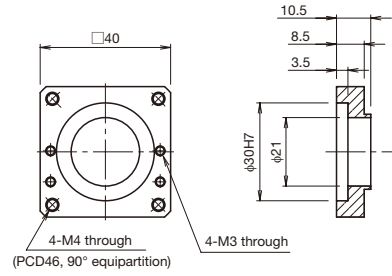

KRF4
AR

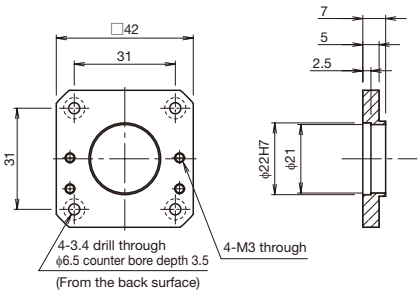

KRF4
AS

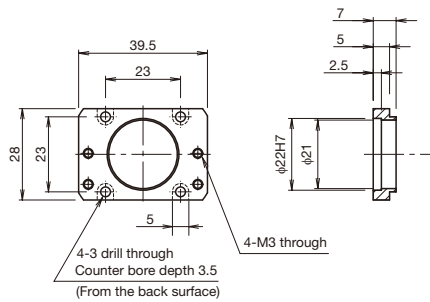

KRF4
AN

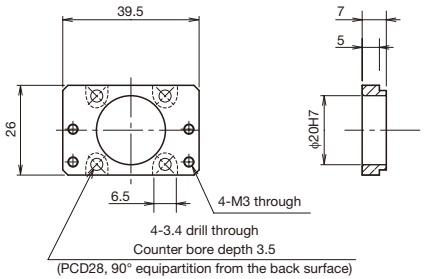

For KRF4R

Motor wrap specification (motor mounting plate)

KRF4R
WP

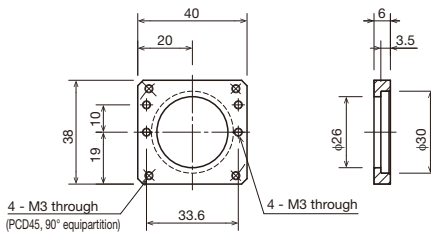

KRF4R
WQ

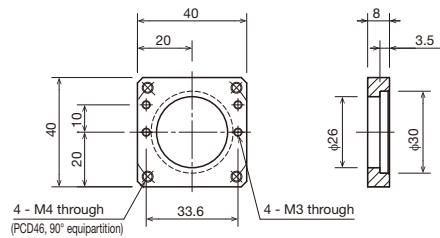

KRF4R
WN

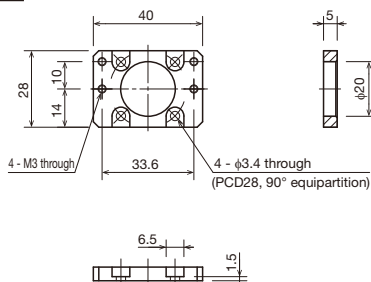

Note) For A0, see the external side view of intermediate flange without motor and the detailed drawing of motor mounting part.

For KRF5

Intermediate flange

KRF5
AP

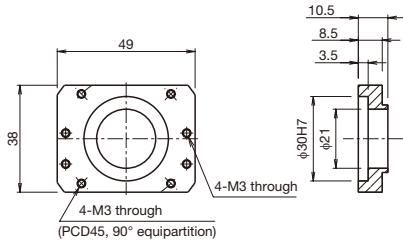

KRF5
AQ

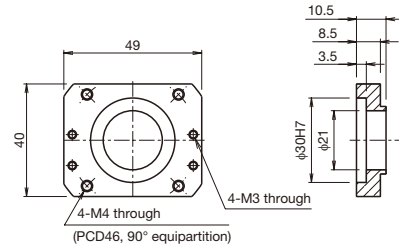

KRF5
AR

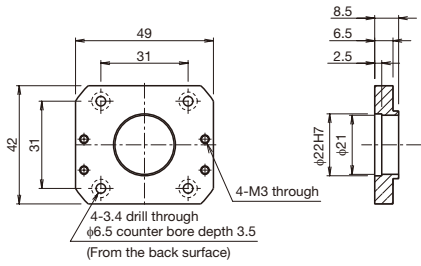

KRF5
AS

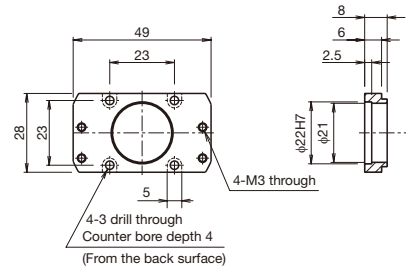

KRF5
AN

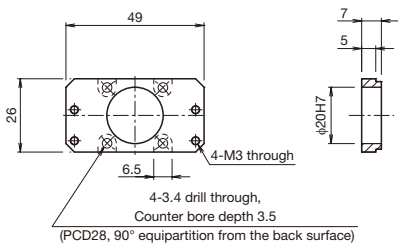

For KRF5R

Motor wrap specification (motor mounting plate)

KRF5R
WP

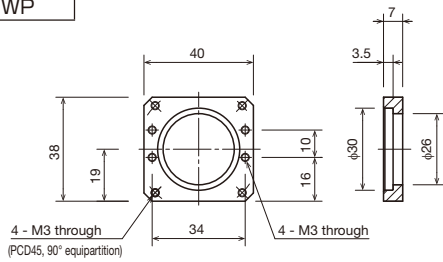

KRF5R
WQ

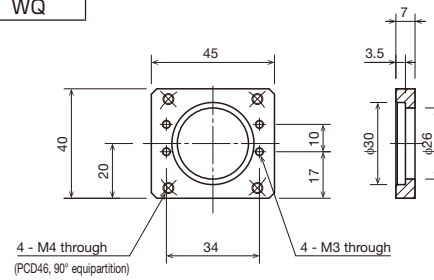

KRF5R
WN

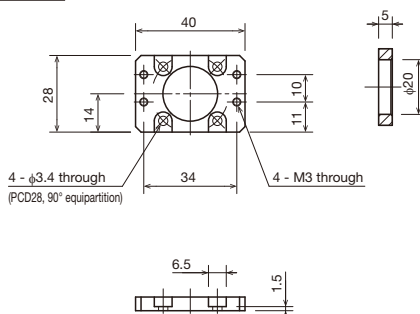

Note) For A0, see the external side view of intermediate flange without motor and the detailed drawing of motor mounting part.

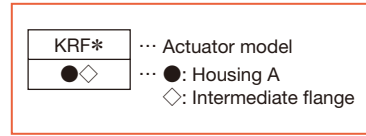

For KRF6

Intermediate flange

KRF6
AP

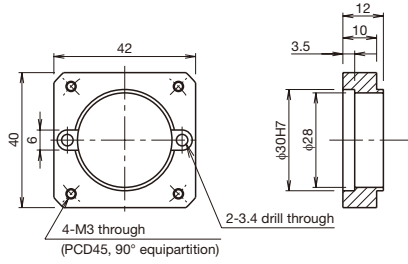

KRF6
AQ

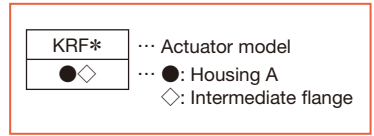
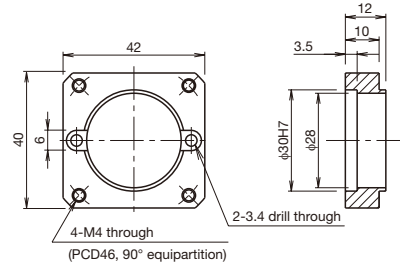

KRF6
AR

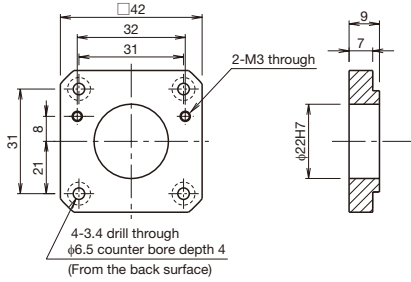

KRF6
AT

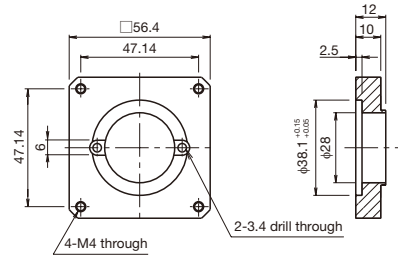

KRF6
AU

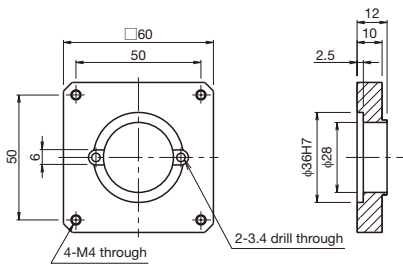

For KRF6R

Motor wrap specification (motor mounting plate)

KRF6R
WP

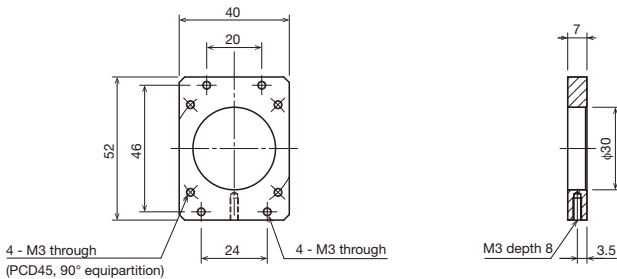

KRF6R
WQ

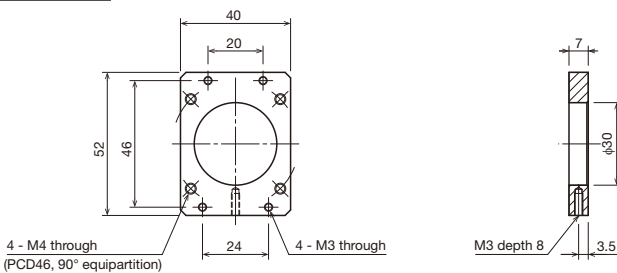

Note) For A0, see the external side view of intermediate flange without motor and the detailed drawing of motor mounting part.

MEMO



Precautions on Use

● Operation

- Do not unnecessarily disassemble the actuator or control device. Doing so may allow foreign objects to enter or reduce functionality.
- Do not drop or knock the actuator or control device. Doing so may cause injury or damage the unit. If the product is dropped or impacted, functionality may be reduced even if there is no surface damage.

● Environment

Wrong environment can cause failures of the actuator and control devices. The best place to use the product is as follows:

- Actuator: A place with an ambient temperature from 0 to 40°C and humidity of 80% RH or lower that will not expose the product to freezing or condensation.
- A place free from corrosive gas and flammable gas.
- A place free from electrically conductive powder (such as iron powder), dust, oil mist, cutting fluid, moisture, salt, and organic solvent.
- A place free from direct sunlight and radiant heat.
- A place free from strong electric and magnetic fields.
- A place where vibration or impact is not transmitted to the unit.
- A place that is easily accessible for service and cleaning purposes.

● Safety Precautions

- When the actuator is in motion or about to be in motion, do not touch any moving parts. Do not go near the actuator when it is in motion.
- Before performing installation, adjustment, checking, or services regarding and the connected peripherals, ensure that all power is disconnected. In addition, take countermeasures to prevent anyone other than the operator from turning on the power.
- If two or more people are involved in the operation, confirm the procedures such as sequences, signs, and abnormalities in advance, and appoint another person for monitoring the operation.
- Before operation, please read thoroughly and obey "Manipulating industrial robots - Safety" (JIS B8433) and "Ordinance on Industrial Safety and Health" (Ministry of Health, Labor and Welfare).
- Operation of the actuator over the torque limit value leads to damage of parts or injury. Please keep the torque limit settings of parameters within THK specifications.
- Although a stopper is installed inside the product, it is intended to limit the stroke and therefore may be damaged in case of a hard collision.

● Lubrication

- Thoroughly remove anti-rust oil and feed lubricant before using the product.
- In order to effectively use the actuator, lubrication is required. Insufficient lubrication may increase abrasion on the rolling part and shorten service life.
- Do not use a mix of lubricants with different physical properties.
- Please contact THK if using special lubricants.
- When adopting oil lubrication, contact THK for details.
- The greasing interval may vary depending on the usage conditions, so THK recommends determining a greasing interval during the initial inspection.

● Storage

- When storing the actuator, enclose it in a package designated by THK and store it in a horizontal orientation while avoiding high temperature, low temperature and high humidity.

**ACTUATOR
UNITS**

Compact Series KRF

- LM Guide is registered trademarks of THK CO., LTD.
- The actual products may differ from the pictures and photographs in this catalog.
- Outward appearances and specifications are subject to change without notification for the purpose of improvement.
- Although great care has been taken in the production of this catalog, THK will not take any responsibility for damage resulting from typographical errors or omissions.
- In exporting our products and technology, or selling them for the purpose of export, THK has a basic policy of observing laws relating to foreign exchange, trade and other laws. For export of THK products as single items, please contact THK in advance.

All rights reserved.

THK CO., LTD.

Head Office 3-11-6 Nishigotanda, Shinagawa-ku, Tokyo 141-8503 JAPAN
 International Sales Department Phone:+81-3-5434-0351 Fax:+81-3-5434-0353
 Global site : <http://www.thk.com/>

NORTH AMERICA

THK America, Inc.

● HEADQUARTERS

Phone:+1-847-310-1111 Fax:+1-847-310-1271

● CHICAGO OFFICE

Phone:+1-847-310-1111 Fax:+1-847-310-1182

● NORTH EAST OFFICE

Phone:+1-631-244-1565 Fax:+1-631-244-1565

● ATLANTA OFFICE

Phone:+1-770-840-7990 Fax:+1-770-840-7897

● LOS ANGELES OFFICE

Phone:+1-949-955-3145 Fax:+1-949-955-3149

● SAN FRANCISCO OFFICE

Phone:+1-925-455-8948 Fax:+1-925-455-8965

● DETROIT OFFICE

Phone:+1-248-858-9330 Fax:+1-248-858-9455

● TORONTO OFFICE

Phone:+1-905-820-7800 Fax:+1-905-820-7811

SOUTH AMERICA

THK BRAZIL INDUSTRIA E COMERCIO LTDA.

Phone:+55-11-3767-0100 Fax:+55-11-3767-0101

EUROPE

THK GmbH

● EUROPEAN HEADQUARTERS

Phone:+49-2102-7425-555 Fax:+49-2102-7425-556

● DÜSSELDORF OFFICE

Phone:+49-2102-7425-0 Fax:+49-2102-7425-299

● STUTTGART OFFICE

Phone:+49-7141-4988-500 Fax:+49-7141-4988-888

● U.K. OFFICE

Phone:+44-1384-47-1550 Fax:+44-1384-47-1551

● ITALY OFFICE

Phone:+39-02-9901-1801 Fax:+39-02-9901-1881

● SWEDEN OFFICE

Phone:+46-8-445-7630 Fax:+46-8-445-7639

● AUSTRIA OFFICE

Phone:+43-7229-51400 Fax:+43-7229-51400-79

● SPAIN OFFICE

Phone:+34-93-652-5740 Fax:+34-93-652-5746

● TURKEY OFFICE

Phone:+90-216-362-4050 Fax:+90-216-569-7150

● PRAGUE OFFICE

Phone:+420-2-41025-100 Fax:+420-2-41025-199

● MOSCOW OFFICE

Phone:+7-495-649-80-47 Fax:+7-495-649-80-44

THK Europe B.V.

● EINDHOVEN OFFICE

Phone:+31-040-290-9500 Fax:+31-040-290-9599

THK France S.A.S.

● PARIS OFFICE

Phone:+33-1-7425-3800 Fax:+33-1-7425-3799

CHINA

THK (CHINA) CO., LTD.

● HEADQUARTERS

Phone:+86-411-8733-7111 Fax:+86-411-8733-7000

● SHANGHAI OFFICE

Phone:+86-21-6219-3000 Fax:+86-21-6219-9890

● BEIJING OFFICE

Phone:+86-10-8441-7277 Fax:+86-10-6590-3557

● CHENGDU OFFICE

Phone:+86-28-8526-8025 Fax:+86-28-8525-6357

● GUANGZHOU OFFICE

Phone:+86-20-8523-8418 Fax:+86-20-3801-0456

● SHENZHEN OFFICE

Phone:+86-755-2642-9587 Fax:+86-755-2642-9604

● XIAN OFFICE

Phone:+86-29-8834-1712 Fax:+86-29-8834-1710

THK (SHANGHAI) CO., LTD.

Phone:+86-21-6275-5280 Fax:+86-21-6219-9890

TAIWAN

THK TAIWAN CO., LTD.

● TAIPEI HEAD OFFICE

Phone:+886-2-2888-3818 Fax:+886-2-2888-3819

● TAICHUNG OFFICE

Phone:+886-4-2359-1505 Fax:+886-4-2359-1506

● TAINAN OFFICE

Phone:+886-6-289-7668 Fax:+886-6-289-7669

KOREA

SEOUL REPRESENTATIVE OFFICE

Phone:+82-2-3468-4351 Fax:+82-2-3468-4353

SINGAPORE

THK LM System Pte. Ltd.

Phone:+65-6884-5500 Fax:+65-6884-5550

THAILAND

THK RHYTHM(THAILAND) CO., LTD. LM System Division

● Bangkok Branch

Phone:+66-2751-3001 Fax:+66-2751-3003

INDIA

THK India Pvt. Ltd.

● HEADQUARTERS & Bangalore Branch

Phone:+91-80-2340-9934 Fax:+91-80-2340-9937

● Pune Branch

Phone:+91-20-4120-8742

● Chennai Branch

Phone:+91-44-4042-3132

● Ahmedabad Branch

Phone:+91-79-6134-4925

● Delhi Branch

Phone:+91-12-4676-8695