

**LOW COST AND RELIABLE.**

*ECONOMY CLASS*

# BELLOWS COUPLINGS

**SERIES BKC + BKL | 2 – 500 Nm**



**R+W**<sup>®</sup>  
COUPLING TECHNOLOGY

THE ULTIMATE COUPLING FROM 2 – 500 Nm

[www.rwcouplings.com](http://www.rwcouplings.com)



# MODEL BKC + BKL

## Areas of application:

for high dynamic servo drives of:

- Machine tools
- CNC milling / grinding machines
- Woodworking machines
- Assembly machines
- Automated plants
- Textile machines
- Industrial robots
- Processing machines
- Printing machinery
- Packaging machines

## Properties:

- high torsional stiffness
- compensates axial, lateral and angular misalignment
- exact angular transmission of motion and torque
- infinite life and maintenance free

## MODEL

## PROPERTIES

## APPLICATION EXAMPLES

### BKC



#### Economy Class with clamping hub from 15-500 Nm

- compact design
- low cost version
- self opening clamping system optional

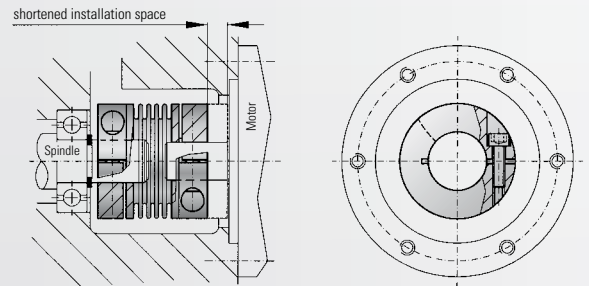

### BKL



#### Economy Class with clamping hub from 2-500 Nm

- low cost version
- self opening clamp system optional

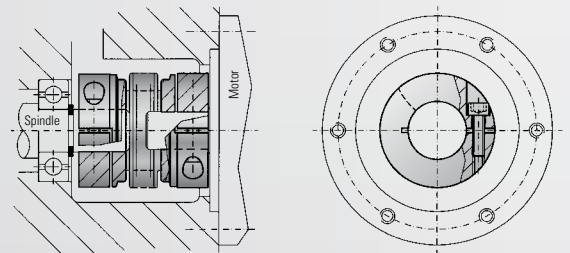

### ATEX



#### for the use in explosive environments

- available for the full product range
- for hazardous areas 1/21 and 2/22 bellows couplings are registered according to the directive ATEX 95/137





# MODEL BKC

## TECHNICAL SPECIFICATIONS

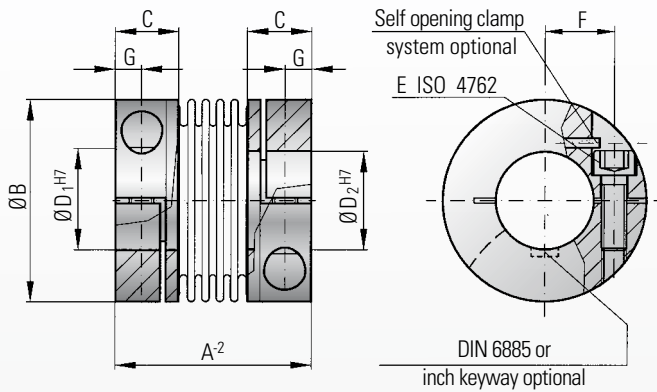

compact version

### Properties:

- compact design
- easy to mount
- suited for space restricted installations
- low moment of inertia
- economically priced

### Material:

Bellows made of highly flexible high-grade stainless steel

### Design:

With a single radial clamping screw per hub ISO 4762.

**Self opening clamp system optional: Loosening the clamping screw applies force to the pin, which will force the clamp into the open position for easy mounting and dismounting.**

### Temperature-range:

-30 to +100° C (3,6 F to 237 F)

### Backlash:

Absolutely backlash-free due to frictional clamped connection.

### Service life:

These couplings have an infinite life and are maintenance-free if the technical specifications are not exceeded.

### Tolerance:

On the hub/shaft connection 0.01 to 0.05 mm.

### Non standard:

Custom designs with varied tolerances, keyways, non-standard material and bellows are available upon request.

### Ordering example

**BKC / 60 / 26 / 22 / XX**

Model  
Series Nm  
Ø D1 H7  
Ø D2 H7  
non standard

Model BKC			Series					
			15	30	60	150	300	500
Rated torque (Nm)	$T_{KN}$		15	30	60	150	300	500
Overall length (mm)	A		48	58	67	78	94	100
Outer diameter (mm)	B		49	56	66	82	110	123
Fit length (mm)	C		16.5	21	23	27.5	34	34
Inner diameter possible from Ø to Ø H7 (mm)	$D_{1/2}$		8-28	12-32	14-35	19-42	24-60	32-75
ISO 4762 fastening screw	E		M5	M6	M8	M10	M12	M12
Tightening torque of the fastening screw (Nm)			8	15	40	75	120	125
Distance between centers (mm)	F		17	20	23	27	39	45
Distance (mm)	G		6.5	7.5	9.5	11	13	13
Moment of inertia ( $10^{-3}$ kgm <sup>2</sup> )	$J_{total}$		0.05	0.09	0.18	0.65	7.2	8.7
Hub material (standard) (steel on request)			AL	AL	AL	AL	Steel	Steel
Approx. weight (kg)			0.13	0.3	0.4	0.8	3.5	4.5
Torsional stiffness ( $10^3$ Nm/rad)	$C_T$		23	31	72	141	157	290
axial	max. Werte	(mm)	1	1	1.5	2	2	2.5
lateral		(mm)	0.15	0.15	0.15	0.15	0.15	0.20
axial spring stiffness (N/mm)	$C_a$		30	50	67	77	112	72
lateral spring stiffness (N/mm)	$C_r$		315	366	679	960	2940	2200

max. angular misalignment 1 degree (1 Nm = 8.85 in lbs)



# MODEL BKL

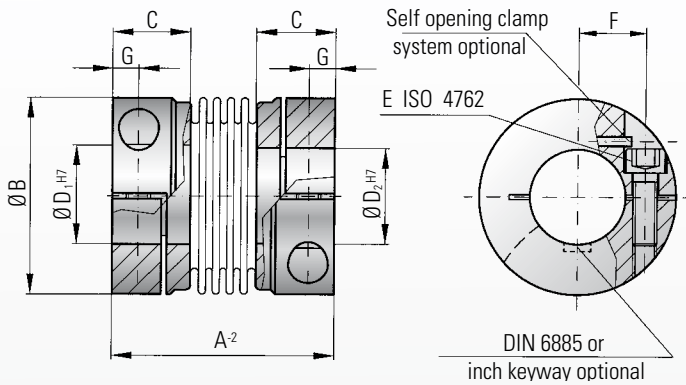

## Ordering example

**BKL / 80 / 26 / 22 / XX**

Model  
Series/Nm  
Ø D1 H7  
Ø D2 H7  
non standard

### Properties:

- easy to mount
- suited for space restricted installations
- low moment of inertia
- economically priced

### Material:

Bellows made of highly flexible high-grade stainless steel

Hub material see technical specifications table

### Design:

With a single radial clamping screw per hub ISO 4762.

**Self opening clamp system optional:**  
**Loosening the clamping screw applies force to the pin, which will force the clamp into the open position for easy mounting and dismounting.**

### Temperature range:

-30 to +100° C (3,6 F to 237 F)

### Backlash:

Absolutely backlash-free due to frictional clamped connection.

### Service life:

These couplings have an infinite life and are maintenance-free if the technical specifications are not exceeded.

### Tolerance:

On the hub/shaft connection 0.01 to 0.05 mm.

### Non standard:

Custom designs with varied tolerances, keyways, non-standard material and bellows are available upon request.

Model BKL		Series										
		2	4,5	10	15	30	60	80	150	300	500	
Rated torque (Nm)	$T_{KN}$	2	4.5	10	15	30	60	80	150	300	500	
Overall length (mm)	A	30	40	44	58	68	79	92	92	109	114	
Outer diameter (mm)	B	25	32	40	49	56	66	82	82	110	123	
Fit length (mm)	C	10.5	13	13	21.5	26	28	32.5	32.5	41	42.5	
Inner diameter possible from Ø to Ø H7 (mm)	$D\frac{1}{2}$	4-13	6-16	6-24	8-28	12-32	14-35	16-42	19-42	24-60	35-62	
ISO 4762 fastening screw	E	M3	M4	M4	M5	M6	M8	M10	M10	M12	M16	
Tightening torque of the fastening screw (Nm)		2.3	4	4.5	8	15	40	70	85	120	200	
Distance between centers (mm)	F	8	11	14	17	20	23	27	27	39	41	
	G	4	5	5	6.5	7.5	9.5	11	11	13	17	
Moment of inertia ( $10^{-3}$ kgm <sup>2</sup> )	$J_{total}$	0.002	0.01	0.02	0.05	0.09	0.18	0.54	1.8   0.65	7.5   2.68	9.0   4.85	
Hub material (standard) (steel on request)		AL	AL	AL	AL	AL	AL	AL	Steel optional AL	Steel optional AL	Steel optional AL	
Approx. weight (kg)		0.02	0.05	0.08	0.13	0.3	0.4	0.7	1.6   0.8	3.8   1.7	4.8   2.2	
Torsional stiffness ( $10^3$ Nm/rad)	$C_t$	1.5	7	9	23	31	72	80	141	157	290	
axial  (mm)	Max. values	0.5	1	1	1	1	1.5	2	2	2	2.5	
lateral  (mm)		0.15	0.15	0.15	0.15	0.15	0.15	0.15	0.15	0.15	0.20	
axial spring stiffness (N/mm)	$C_s$	8	35	30	30	50	67	44	77	112	72	
lateral spring stiffness (N/mm)	$C_s$	50	350	320	315	366	679	590	960	2940	1450	

max. angular misalignment 1 degree (1 Nm = 8.85 in lbs)



# MODEL ATEX

**FOR USE IN HAZARDOUS AREAS AND EXPLOSIVE ATMOSPHERE**



AT mosphere EX possible

**The ATEX 95 / ATEX 137 is regulated by the new European directive. Generally the explosive atmosphere is classified in 3 different zones.**

**Zone 0:**

A place in which an explosive atmosphere is consisting out of a mixture of air and flammable substances in the form of gas, vapor or mist is present frequently, continuously or for longer periods.

**Zone 20:**

Is relevant for an explosive atmosphere in the form of clouds of combustible dust in air under the same conditions as above.

**Zone 1:**

Described as a place in which an explosive atmosphere is existing of a mixture of air and flammable substances in the form of gas, vapor or mist is likely to occur in normal operation occasionally.

**Zone 21:**

Is relevant for an explosive atmosphere in the form of clouds of combustible dust in air under the same conditions as above.

**Zone 2:**

A place in which an explosive atmosphere is consisting out of mixture with air of flammable substances in the form of gas, vapor or mist is not likely to occur in normal operation but, if it does occur, it will persist for a short period only.

**Zone 22:**

Relevant for an explosive atmosphere in the form of a cloud of combustible dust in air under the same conditions as above.

**For the classified zones 1/21 and 2/22 the metal bellows couplings BK-EEEx do have an accreditation according to ATEX 95/137**

## Design of the BK-EEEx metal bellows couplings

**All BK-EEEx metall bellows couplings are designed that neither sparking nor an increasing in excess of the allowable temperature at the surface can occur, even while malfunctions.**

All dimensions of the standard models are retained. The coupling hubs are generally equipped with internal jaws for additional support of the bellows. If the bellows were to tear or break, the internal jaws would eliminate the risk of sparking or heating and continue to drive the load. In case of damage the angle of turn between the driving and the driven side is  $\pm 4^\circ$  degrees . All hubs are made of steel or stainless steel materials only.

**ATTENTION!**

**A monitoring of the driving- and driven face is required.**

The shut off function has to take place immediately.

**Mounting, Design:**

**Installation and Operation instructions:**

**Identification:**

**Example Accreditation data:**

For security reasons all misalignment values and torque ratings are decreased by 20%

Installation and operating instructions are an essential part of the BK-EEEx metal bellows couplings.

Including the following facts:

- design of the BK EEx metal bellows couplings
- exact tightening torques and misalignment values
- how to put in operation
- maintenace intervals
- trouble shooting
- marking of the coupling
- declaration of conformity

All BK-EEEx couplings are permanent labeled to display manufacturer and accreditation data.

	Type: BKL 150 EEx-2003
	II 2 G D
	EEx II c 40°C
	Ser.No.: A 44305
	Tech.Ref.No.:2003/003RW

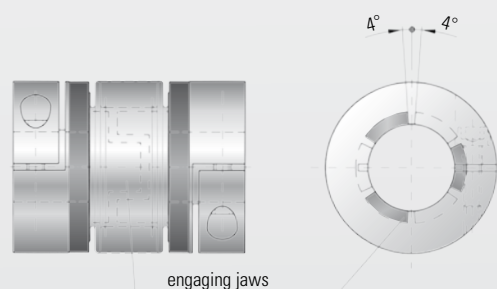





# THE SELECTION

## According to torque

In most cases couplings are rated according to the maximum peak torque to be regularly transmitted.

The peak torque may not exceed the rated torque of the coupling.

By rated torque we mean: the torque that is continuously transmittable within the specified acceptable speed and misalignment ranges.

The following calculation has proven itself to be a good rule of thumb:

$$T_{KN} \geq 1,5 \cdot T_{AS} \quad (\text{Nm})$$

$T_{KN}$  = rated torque of coupling (Nm)

$T_{AS}$  = peak torque of motor (Nm)

## According to acceleration torques

For precise rating, the acceleration torque and moments of inertia of the entire machine have to be taken into consideration.

In the case of servo motors ensure that their acceleration or deceleration torque is greater than their torque by a multiple.

$S_A$  = Shock or load factor

$S_A = 1$  (uniform load)

$S_A = 2$  (non-uniform load)

$S_A = 3-4$  (Shocking load)

Values for  $S_A = 2-3$  are usual for servo drives on machine tools.

$$T_{KN} \geq T_{AS} \cdot S_A \cdot \frac{J_L}{J_A + J_L} \quad (\text{Nm})$$

$T_{KN}$  = rated torque of coupling (Nm)

$T_{AS}$  = max. acceleration torque on the on the drive face (Nm)

- or max. deceleration torque of the load face (Nm)

$J_L$  = machine's moment of inertia (Spindle + slide + workpiece+ half of coupling) (kgm<sup>2</sup>)

$J_A$  = motor's moment of inertia (kgm<sup>2</sup>)

## According to resonance frequency

For the mech. substitutional model of the 2-mass-system is valid:

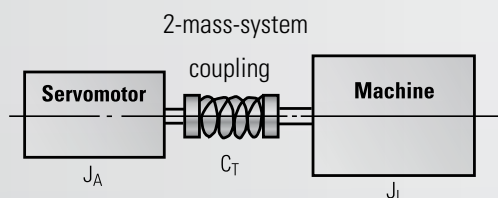

As a value of practise is valid:  $f_e \geq 2 \times f_{er}$

$$f_e = \frac{1}{2 \cdot \pi} \sqrt{C_T \cdot \frac{J_A + J_L}{J_A \cdot J_L}} \quad (\text{Hz})$$

$C_T$  = torsional stiffness of the coupling (Nm/rad)

$f_e$  = resonance frequency of the 2 mass system (Hz)

$f_{er}$  = frequency of the drive (Hz)

## According to torsional stiffness

Transmission errors due to the torsional load:

$$\varphi = \frac{180}{\pi} \cdot \frac{T_{AS}}{C_T} \quad (\text{degrees})$$

$\varphi$  = angle of turn (degrees)

$C_T$  = torsional stiffness of coupling (Nm/rad)

$T_{AS}$  = max. torque (Nm)

# INSTALLATION INSTRUCTION

## Mounting preparation

- In the case of models BKC / BKL the tolerance between shaft/hub connection must not exceed 0.01 and 0.05 mm.
- Prior to mounting check for smooth running of the coupling hub on the shaft.
- Prior to mounting, make sure that the shaft is slightly oiled. Shaft keyways have no effect upon the function of the clamped connection.
- When mounting the coupling ensure that the metal bellows are not damaged or bent.
- During mounting, the torque and axis misalignments may exceed 2 times the value specified without the operation of the coupling being restricted.
- However, for continuous operation, the axial and lateral misalignments specified in the catalog must not be exceeded. Only then the coupling will provide infinite performance. **Lateral axis misalignment requires special attention** (see table values).

## Maximum shaft misalignments

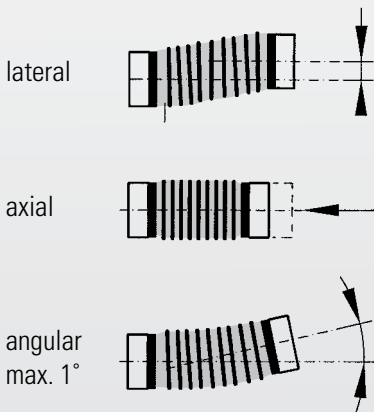

**CAUTION:** Lateral misalignment has a negative effect on the service life to the bellows. Exact alignment of the R+W metal bellows coupling considerably increases the service life of the coupling. By reducing or eliminating lateral misalignment the radial loading of the adjacent bearings is eliminated increasing service life and reducing heat.

For drives running at high speed we recommend aligning the R+W metal bellows coupling with a dial indicator. (see values at table page 3 + 4)

## Mounting

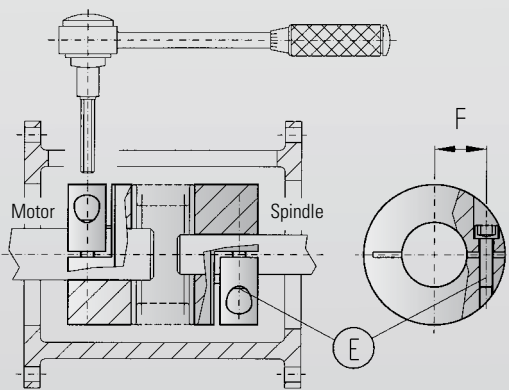

### Mounting:

Prior to mounting make sure that the shafts to be connected do not exceed the angular or lateral misalignment limits for the coupling to be used. This data can be found in the catalog. Slide the metal bellows coupling onto the motor shaft end. When the correct axial position has been reached tighten the clamp screw (E) to the correct tightening torque as indicated in table 1 with a torque wrench. Insert the spindle shaft into the other end of the coupling to the proper axial position. Make sure that the coupling is free of any axial forces before tightening. Tighten the clamp screw (E) as above using a torque wrench to the proper tightening torque. For the split hub design it is necessary to maintain the proper separation between shaft ends (dimension H in the catalog).

### Dismounting:

Simply loosen the clamp screws and remove the coupling.

## Maintenance

R+W metal bellows couplings are maintenance free as long as they are properly mounted and the maximum misalignment values are not exceeded.

**Experience and  
Know-how  
for your special  
requirements.**

R+W Antriebselemente GmbH  
Alexander-Wiegand-Straße 8  
D-63911 Klingenberg/Germany

Tel. +49-(0)9372 – 9864-0  
Fax +49-(0)9372 – 9864-20

info@rw-kupplungen.de  
www.rwcouplings.com



TGA-ZM-05-91-00  
Registration No. 9605022

The information mentioned in this document is based on our present knowledge and experiences and does not exclude the manufacturer's own substantial testing of the equipment. So this is no obligatory assurance even with regard to protection rights of Third Parties. The sale of our products is subject to our General Conditions of Sale and Delivery.

# THE R+W-PRODUCT RANGE



## **TORQUE LIMITERS Series SK**

From 0,1 – 2.800 Nm, Bore diameters 4 – 100 mm  
Available as a single position, multi-position, load holding, or full disengagement version  
Single piece or press-fit design



## **BELLOWS COUPLINGS Series BK**

From 15 – 10.000 Nm  
Bore diameters 10 – 180 mm  
Single piece or press-fit design



## **BELLOWS COUPLINGS ECONOMY CLASS Series BKC / BKL**

From 2 – 500 Nm  
Bore diameters 4 – 62 mm



## **LINE SHAFTS Series ZA/ZAe**

From 10 – 4.000 Nm  
Bore diameters 10 – 100 mm  
Available up to 6 mtr. length



## **MINIATURE BELLOWS COUPLINGS Series MK**

From 0,05 – 10 Nm  
Bore diameters 1 – 28 mm  
Single piece or press-fit design



## **SERVOMAX<sup>®</sup> ELASTOMER COUPLINGS Series EK**

From 2 – 2.000 Nm  
Shaft diameters 5 – 80 mm  
backlash-free, press-fit design



## **LINEAR COUPLINGS Series LK**

From 70 – 2.000 N  
Thread M5 – M16



## **POLYAMID COUPLINGS MICROFLEX Series FK 1**

Rated torque 1 Ncm  
Bore diameters 1 – 1,5 mm