

Rothe Erde® Slewing Bearings.



Rothe Erde



ThyssenKrupp

With slewing bearings and quality rings to global success.

Rothe Erde is the worldwide leading manufacturer of slewing bearings (including ball and roller bearing slewing rings and wire-race bearings). Rothe Erde enjoys a leading market position for seamless rolled steel and non-ferrous metal rings. Furthermore, Rothe Erde is a well-known manufacturer of turntables and structural elements.

Rothe Erde slewing bearings are for decades state of the art technology and practice-proven all over the world, in a wide variety of applications.

Rothe Erde manufactures slewing bearings up to 8,000 mm diameter as monobloc systems and segmental bearings in larger dimensions.

Rothe Erde slewing bearings are manufactured in Germany and by Rothe Erde subsidiaries in Great Britain, Italy, Spain,

the United States, Brazil, Japan and China. The market presence of Rothe Erde in all major industrialised countries is maintained by own distributors or sales agencies.

Total commitment to quality is common to Both, our domestic and foreign production facilities. All service and areas from applications consulting to design and manufacturing, including comprehensive customer service, are based on the international DIN/ISO 9001/2000 quality standard series.

Examples for applications:

- Antennas and Radar
- Equipment
- Areal Hydraulic Platforms
- Aviation and Aerospace Units
- Bogie Bearings for Vehicles
- Communication Systems
- Excavators
- Harbour and Shipyard Cranes
- Machine Tools
- Mechanical Engineering
- Mobile Cranes
- Offshore Technology
- Packaging and Filling Machines
- Rail Vehicles
- Ship Deck Cranes
- Stackers and Reclaimers
- Steelmill Equipment
- Telescopes
- Tower Cranes
- Tunnelling Machines
- Water Treatment Equipment
- Wind and Solar Energy Plants



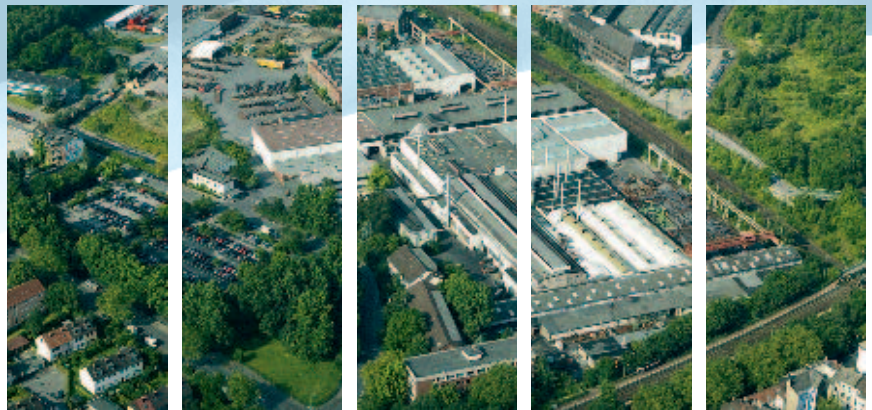

Plant Dortmund

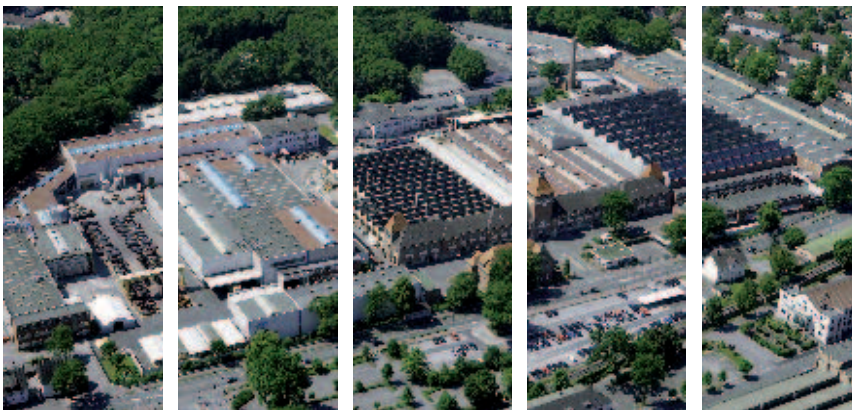

Plant Lippstadt

Bearing design types Basic information

Pages 6 – 41

Standard series KD 210

Single-row ball bearing slewing rings
Profile bearings

Pages 43 – 55

Standard series KD 320

Double-row ball bearing slewing rings
Double axial ball bearings

Pages 57 – 83

Standard series KD 600

Single-row ball bearing slewing rings
Four-point contact bearings

Pages 85 – 121

Standard series RD 700

Double-row slewing rings
Roller/ball combination bearings

Pages 123 – 133

Standard series RD 800

Single-row roller bearing slewing rings
Cross-roller bearings

Pages 135 – 153

Standard series RD 900

Three-row roller bearing slewing rings
Axial-roller bearings

Pages 155 – 167



Rothe Erde
Slewing Bearings



Bearing design types Basic information

Pages 6 – 41

Bearing design types	6 – 7
Load transmission	8
Bearing selection	9 – 10
Load factors for bearing selection	11
Example of a bearing selection	12 – 14
Service life	15
Example of a service life calculation	16 – 17
Fastening bolts	18 – 23
Loctite-586 Improvement in the frictional bond	24
Gearing	25
Pinion tip radius and tip relief	26
Turning torque calculation	27
Raceway hardening	28
Quality assurance	29
Finite Element calculations	30-31
Companion structures	32
Measurement and machining of contact areas, admissible flatness deviations including slope of the companion structure	33 – 34
Operating conditions and special requirements	35
Wear measurement	36 – 37
Installation, Lubrication, Maintenance	38 – 40
Drawing number composition	41

Bearing design types.



Rothe Erde
Slewing Bearings

Standard series KD 210

Single-row ball bearing slewing rings
Profile bearings

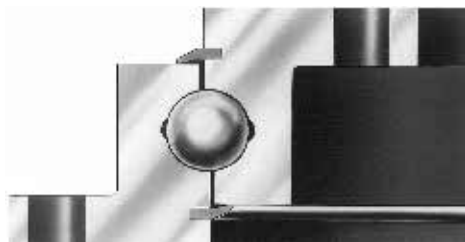

KD 210 standard bearing types 21 and 110 are available

- without gear
- with external gear
- with internal gear

Type 13 is supplied

- without gear

Applications:
e.g. vehicle construction,
general mechanical engineering.

For bearings with similar dimensions as type 21, but with higher load capacities:
see standard series KD 600, Pages 90 and 91.

Standard series KD 320

Double-row ball bearing slewing rings
Double-axial ball bearings

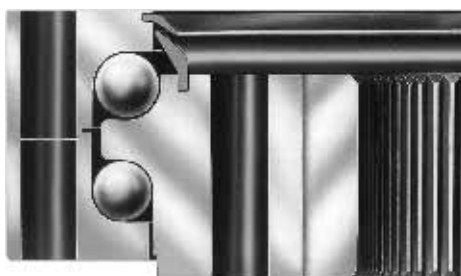
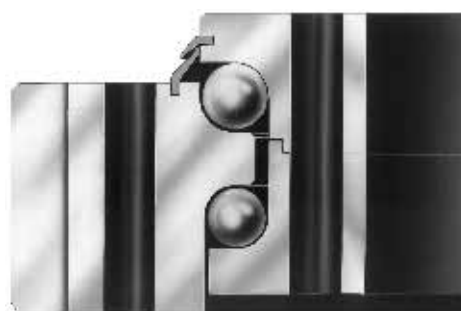

KD 320 standard bearings are available

- without gear
- with external gear
- with internal gear
- drawing position = mounting position

Applications:
e.g. mechanical handling, mining and materials
handling.

Standard series KD 600

Single-row ball bearing slewing rings
Four-point contact bearings

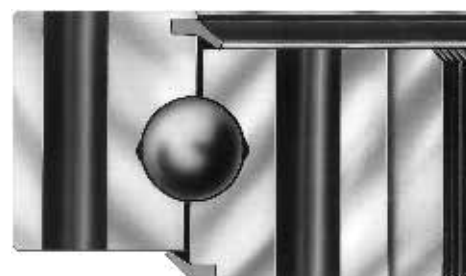
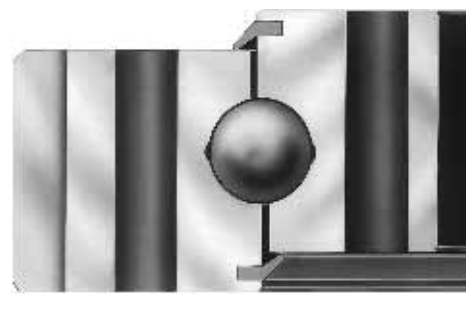
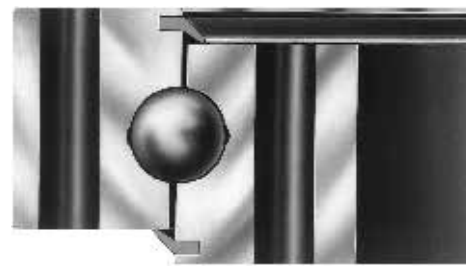

KD 600 standard bearings are available

- without gear
- with external gear
- with internal gear

Applications:
e.g. hoisting and mechanical handling, general
mechanical engineering.

Bearing design types.

Standard series RD 700

Double-row slewing rings
Roller/ball combination bearings

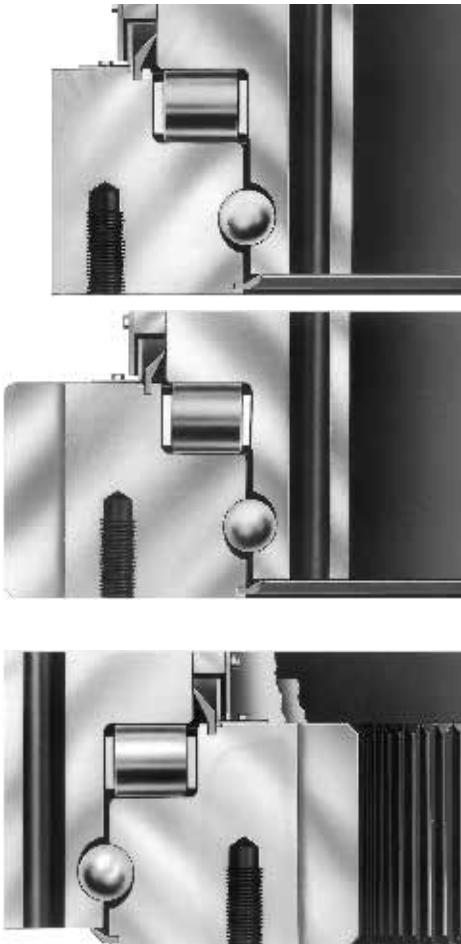

RD 700 standard bearings are available

- without gear
- with external gear
- with internal gear
- drawing position = mounting position

Applications:
e.g. mining and materials handling.

Standard series RD 800

Single-row roller bearing slewing rings
Cross-roller bearings



RD 800 standard bearings are available

- without gear
- with external gear
- with internal gear

Applications:
e.g. hoisting and mechanical handling, general mechanical engineering.

Standard series RD 900

Three-row roller bearing slewing rings
Axial-roller bearings



RD 900 standard bearings are available

- without gear
- with external gear
- with internal gear
- drawing position = mounting position

Applications:
e.g. hoisting, mechanical handling, mining and materials-handling, offshore technology, general mechanical engineering.

Load transmission.



Rothe Erde large-diameter antifriction bearings are ready for installation, transmitting axial and radial forces simultaneously as well as the resulting tilting moments.

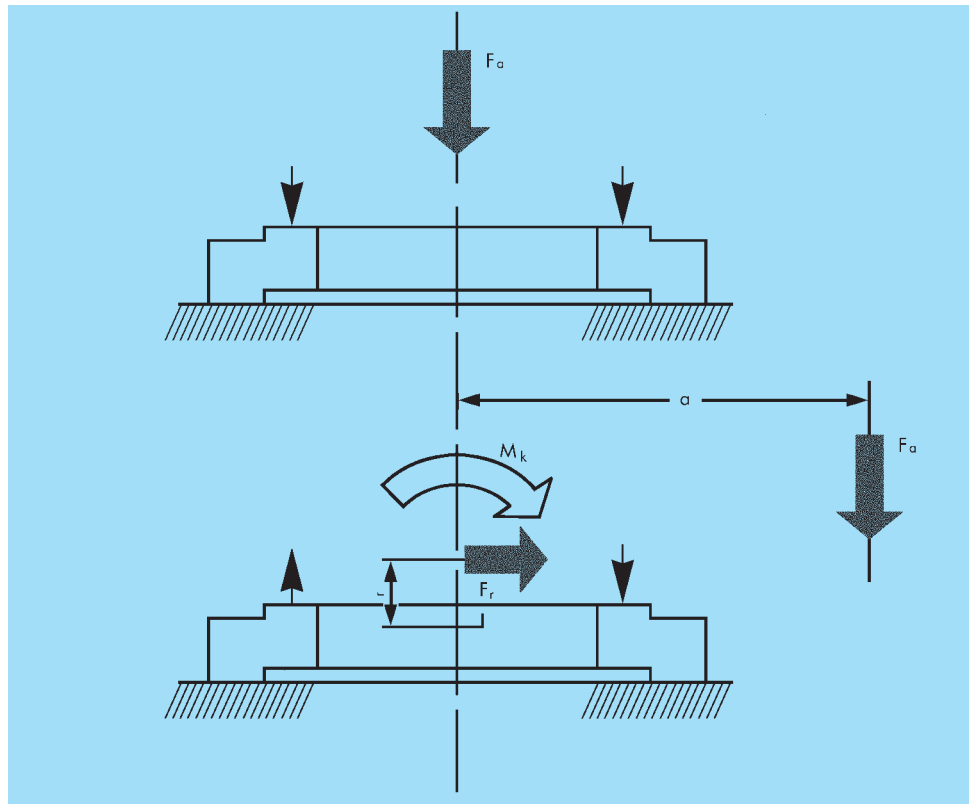

Fig. 1:
Large antifriction bearings are generally installed supported on the lower companion structure.

Fig. 1

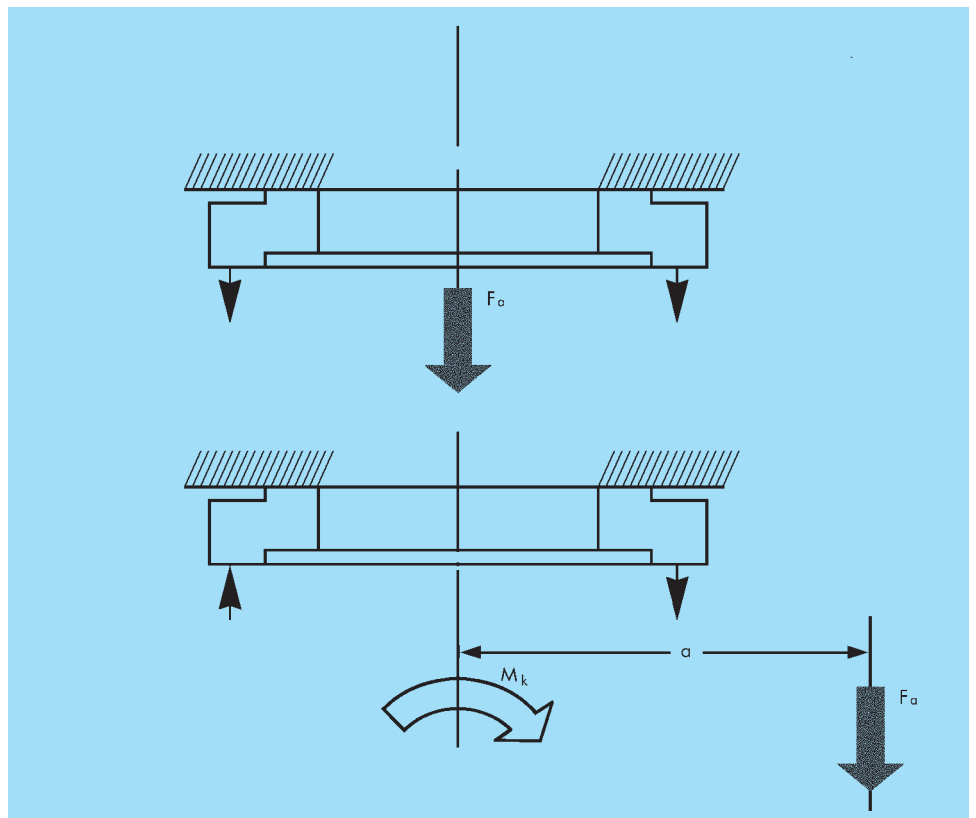

Fig. 2:
Suspended installations require an increased number of fastening bolts. The bolt curves shown in the diagrams do not apply in such a case. Calculation to be carried out by RE.

Fig. 2

Bearing selection.



Rothe Erde® Slewing Bearings		KD 100 Questionnaire	
Company: _____		Department: _____	
Name: _____		Phone: _____	
Address: _____		Fax: _____	
_____		e-mail: _____	
Country: _____		Phone/Visit on: _____	
Customer project: _____			
Rothe Erde Inquiry-No.: _____		Rothe Erde Order-No.: _____	
Application:	Axis of rotation: Horizontal <input type="checkbox"/> vertical <input type="checkbox"/> mutual <input type="checkbox"/> 	Bearing under: compression <input type="checkbox"/> tension* <input type="checkbox"/> *Bolts under tension by axial loads	
Gear: free choice <input type="checkbox"/> as per annex B <input type="checkbox"/>	external <input type="checkbox"/> internal <input type="checkbox"/> without <input type="checkbox"/>	Movement: Positioning only <input type="checkbox"/> Intermittent rotation <input type="checkbox"/> Continuous rotation <input type="checkbox"/>	No. of revolutions [rpm]: norm.: _____ max.: _____
Bearing loads			
Magnitude and direction of loads and their distance (related to axis of rotation)	A max. working load	B max. test load e.g. 25% overload condition	C Extreme load e.g. shocks or out of operation
Axial loads parallel to axis of rotation			[kN]
Radial loads at right angle to axis of rotation (without gear loads)			[kN]
Resulting moment			[kNm]
Tangential force per drive [kN]:		No. of drives:	
norm.: _____ max.: _____		Position: _____ ° apart	
Existing or chosen bearing per drawing No.:			
For continuous rotation, variable and B10 life requirements, please complete annex A.			
Annex A is enclosed: <input type="checkbox"/>			
Remarks: (e.g. special working conditions / temperatures, required accuracies, bearing dimensions, inspection- or certification requirements, material tests etc.)			
Please fully complete this form. Incomplete information will delay our proposal.			
Individual consultation required. Please call for appointment <input type="checkbox"/>			
Date		Signature	

07.05.2003 TA / Habener

The final and binding selection of a large-diameter antifriction bearing is principally made by us.

Selection determines the correct dimensioning of bearing races, gearing and bolt connections.

We, therefore require that you complete our KD 100 applications questionnaire to provide us with all necessary data to help in selection of the appropriate bearing.

The most important data for choosing the right bearing are:

1. Applied loads
2. Collective loads with respective time percentages
3. Speed or number of movements and angle per time unit together with the relating collective loads
4. Circumferential forces to be transmitted by the gearing
5. Bearing diameter
6. Other operating conditions.

Full completion of the KD 100 form will enable us to largely respect your requests and prepare a technically adequate and economical bearing proposal.

Whenever possible, the completed KD 100 form should be submitted to us during the planning stage, but no later than the order placement to allow for confirmation of the bearing.

Bearing selection by catalogue

This catalogue permits you to make an approximate bearing selection to be used in your project work.

The Rothe Erde bearings listed in this catalogue are allocated critical load curves for their static load capacity as well as service life curves.

For defining the required bearing load capacity, the determined loads must be multiplied by the "load factors" indicated in Table 1 for the various application cases, except for types 13 and 21 of the KD 210 type series. If no applications are indicated, comparable factors have to be used, depending on the mode of operation.



Static load capacity

The determined loads must be multiplied with a factor f_{stat} allocated to the application. The product F_a' or M_k' must be below the static critical load curve of the selected bearing.

With regard to radial loads in load combinations

- F_a = axial load
- F_r = radial load
- M_k = tilting moment

the reference loads for the “static” bearing selection from the KD 210 and KD 600 type series are computed as follows according to I or II:

Load combination I

$$F_a' = (F_a + 5,046 \cdot F_r) \cdot f_{stat}$$
$$M_k' = M_k \cdot f_{stat}$$

Load combination II

$$F_a' = (1,225 \cdot F_a + 2,676 \cdot F_r) \cdot f_{stat}$$
$$M_k' = 1,225 \cdot M_k \cdot f_{stat}$$

I and II apply analogously to types 13 and 21, but without the factor f_{stat} .

A bearing is statically suitable if one of the two load combinations (I or II) is below the static critical load curve.

The reference load for the RD 800 type series is:

$$F_a' = (F_a + 2,05 \cdot F_r) \cdot f_{stat}$$
$$M_k' = M_k \cdot f_{stat}$$

The bearing is statically suitable if one of the two load combinations (I or II) is below the static critical load curve.

For the KD 320 and RD 700 type series, radial loads $F_r \leq 10\%$ of the axial load can be neglected in selecting bearings by critical load curves.

If the radial load is $F_r > 10\%$ of the axial load, the supporting angle must be taken into account. The respective calculation will then be done by us.

In the RD 900 type series, radial loads have no influence on the critical load curve.

Service life

The operating load multiplied by factor f_L is analogously transferred to the service life curve.

If the expected service life deviates from the value allocated to the factor, or if the service life is to be determined by the collective loads and time units, see “Service life”, Pages 15–17.

Load Factors for bearing selection.



Except for Standard series KD 210, types 13 and 21

Table 1

Application	$f_{stat.}$	f_L	Service Time in Full Load Revolutions		
Floating Crane (Cargo)	1.10	1.0	30,000	<p>Static rating principally requires taking into account the maximum occurring loads which must include additional loads and test loads.</p> <p>Static safety factors ($f_{stat.}$ e.g. for erection loads, higher test loads etc.) must not be reduced without prior written approval from us for exceptional cases.</p> <p>The “f_L” values shown refer to a rating for max. operating load and have been obtained from operating experience and tests. If a load spectrum with an assumed <i>average</i> load is used to obtain the required full load revolutions, the service time values must be increased accordingly.</p> <p>For applications not listed in the chart, guidance values for similar operating conditions and comparable applications may be used.</p> <p>*) Tower Cranes with bearing at top: $M_{krü}$ = restoring moment without load M_k = Moment at max. radius with load</p> <p>***) For applications requiring a rating of $f_{stat.} = 1.45$, multi-row designs should be given preference because of the high average loads and arduous operating conditions.</p>	
Mobile Crane (Cargo)					
Ship Deck Crane (Grab)					
Welding Positioner					
Turntable (Permanent Rotation)					
Tower Crane Bearing at top*	1.25	1.0	30,000		
					$M_{krü} \leq 0.5 M_k$
					$0.5 M_k \leq M_{krü} \leq 0.8 M_k$
Bearing at base	1.0	30,000			
Slewing Crane (Cargo)	1.15	1.15	45,000		
Shipyards Crane					
Rotatable Trolley (Cargo)					
Shiploader/Ship Unloader					
Steel Mill Crane	1.45**	1.5	100,000		
Mobile Crane (Grab or heavy handling service)		1.7	150,000		
Slewing Crane (Grab/Magnet)					
Rotatable Trolley (Grab/Magnet)					
Bridge Crane (Grab/Magnet)					
Floating Crane (Grab/Magnet)		2.15	300,000		
Main slewing gear of Bucket Wheel Excavator					
Reclaimer					
Stacker					
Boom Conveyor					
Offshore Crane	subject to special criteria				
Railway Crane	1.10	For these applications please mind the accompanying note.		<p>Note:</p> <p>In these applications, the operating conditions, particularly the operating time and the loads during the slewing process, vary considerably. Infrequent slewing motions, e.g. occasional positioning for certain jobs, may permit a rating on static criteria alone. On the other hand, continuous rotation or oscillating motions will require a rating on the basis of service time criteria. Selections based on service time may also be required if the bearing carries out relative movements, which is often the case with the discharge boom conveyors in bucket wheel units.</p>	
Deck Crane (Cargo)	1.00				
Stacker	1.10				
Boom Conveyor					
Conveyor Waggon	1.25				
Cable Excavator/Drumline					
Swing Shovel	1.25				
Hydraulic Excavator Bearing from KD 320 series					
Other bearing types					
Hydraulic Excavator up to 1.5 m ³	1.45				
exceeding 1.5 m ³	subject to special criteria				
Ladle Car	1.75				

Example of a bearing selection.

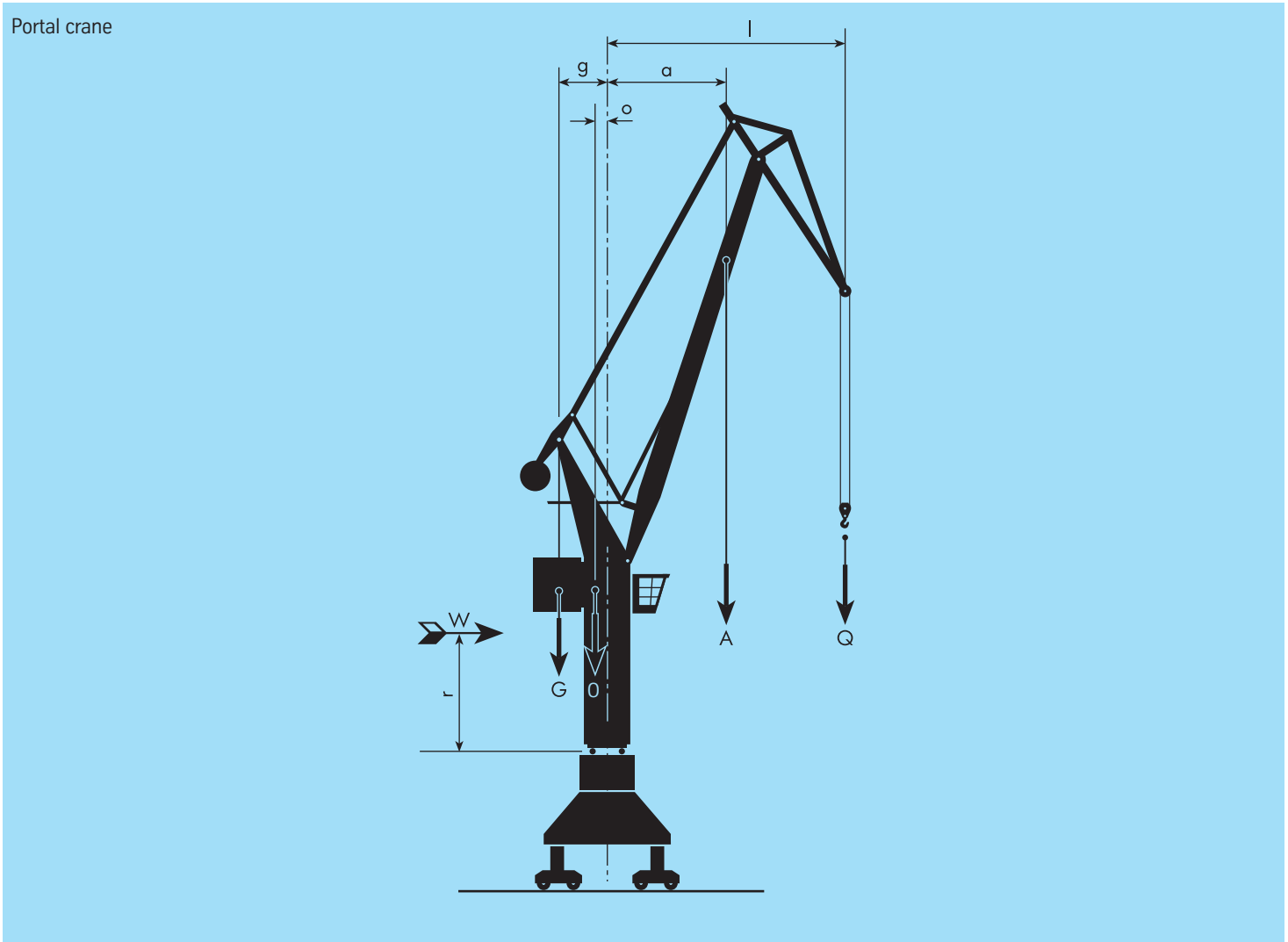

Fig. 3

The maximum load must be determined using the formulae listed opposite.

The loads thus determined must be multiplied by the load factors (see Table 1, Page 11) before the bearing can be selected.

The following factors will apply to the examples given:

Cargo duty: Load factor $f_{stat.} = 1.25$

Grab duty: Load factor $f_{stat.} = 1.45$

1 Lifting load at maximum radius

1.1) Max. working load including wind:

$$\text{Axial load } F_a = Q_1 + A + O + G$$

$$\text{Res. moment } M_k = Q_1 \cdot l_{max} + A \cdot a_{max} + W \cdot r - O \cdot o - G \cdot g$$

1.2) Load incl. 25% test load without wind:

$$\text{Axiallast } F_a = 1,25 \cdot Q_1 + A + O + G$$

$$\text{Res. moment } M_k = 1,25 \cdot Q_1 \cdot l_{max} + A \cdot a_{max} - O \cdot o - G \cdot g$$

2 Lifting load at minimum radius

2.1) Max. working load including wind:

$$\text{Axial load } F_a = Q_2 + A + O + G$$

$$\text{Res. moment } M_k = Q_2 \cdot l_{min} + A \cdot a_{min} + W \cdot r - O \cdot o - G \cdot g$$

2.2) Load incl. 25% test load without wind:

$$\text{Axial load } F_a = 1,25 \cdot Q_2 + A + O + G$$

$$\text{Res. moment } M_k = 1,25 \cdot Q_2 \cdot l_{min} + A \cdot a_{min} - O \cdot o - G \cdot g$$



Crane for cargo duty

at maximum radius

$$\begin{aligned} Q &= 220 \text{ kN} & l_{\max} &= 23 \text{ m} \\ A &= 75 \text{ kN} & a_{\max} &= 11 \text{ m} \\ O &= 450 \text{ kN} & o &= 0.75 \text{ m} \\ G &= 900 \text{ kN} & g &= 3 \text{ m} \\ W &= 27 \text{ kN} & r &= 6.5 \text{ m} \end{aligned}$$

1) Maximum operating load including wind

$$\begin{aligned} F_a &= Q + A + O + G \\ &= 220 + 75 + 450 + 900 \\ F_a &= 1645 \text{ kN} \end{aligned}$$

$$\begin{aligned} M_k &= Q \cdot l_{\max} + A \cdot a_{\max} + W \cdot r - O \cdot o - G \cdot g \\ &= 220 \cdot 23 + 75 \cdot 11 + 27 \cdot 6.5 - 450 \cdot 0.75 - 900 \cdot 3 \\ M_k &= 3023.0 \text{ kNm} \end{aligned}$$

2) Load case incl. 25 % test load without wind

$$\begin{aligned} F_a &= Q \cdot 1.25 + A + O + G \\ &= 275 + 75 + 450 + 900 \\ F_a &= 1700 \text{ kN} \end{aligned}$$

$$\begin{aligned} M_k &= Q \cdot 1.25 \cdot l_{\max} + A \cdot a_{\max} - O \cdot o - G \cdot g \\ &= 275 \cdot 23 + 75 \cdot 11 - 450 \cdot 0.75 - 900 \cdot 3 \\ M_k &= 4112.5 \text{ kNm} \end{aligned}$$

3) Maximum operating load without wind

$$F_a = 1645 \text{ kN}$$

$$\begin{aligned} M_k &= Q \cdot l_{\max} + A \cdot a_{\max} - O \cdot o - G \cdot g \\ &= 220 \cdot 23 + 75 \cdot 11 - 450 \cdot 0.75 - 900 \cdot 3 \\ M_k &= 2847.5 \text{ kNm} \end{aligned}$$

When selecting the bearing, load case 2) should be used for static evaluation, and load case 3) for service life.

The static load capacity of the bearing, taking into account load factor $f_{\text{stat.}} = 1.25$, is checked against the "static limiting load curve", reference load:

$$\begin{aligned} \text{Load case 2)} \quad F_a' &= 1700 \text{ kN} \cdot 1.25 = 2125 \text{ kN} \\ M_k' &= 4112.5 \text{ kNm} \cdot 1.25 = 5140.6 \text{ kNm} \end{aligned}$$

A load factor of $f_L = 1.15$ is used for a service life of 45 000 revolutions under full load, reference load:

$$\begin{aligned} \text{Load case 3)} \quad F_a' &= 1645 \text{ kN} \cdot 1.15 = 1891.7 \text{ kN} \\ M_k' &= 2847.5 \text{ kNm} \cdot 1.15 = 3274.6 \text{ kNm} \end{aligned}$$

The number of bolts and strength class will be determined for the max. load without a factor:

$$\begin{aligned} \text{Load case 2)} \quad F_a &= 1700 \text{ kN} \\ M_k &= 4112.5 \text{ kNm} \end{aligned}$$

Crane for grab duty

at maximum radius

$$\begin{aligned} Q &= 180 \text{ kN} & l_{\max} &= 19 \text{ m} \\ A &= 110 \text{ kN} & a_{\max} &= 9 \text{ m} \\ O &= 450 \text{ kN} & o &= 0.75 \text{ m} \\ G &= 900 \text{ kN} & g &= 3 \text{ m} \\ W &= 27 \text{ kN} & r &= 6.5 \text{ m} \end{aligned}$$

1) Maximum operating load including wind

$$\begin{aligned} F_a &= Q + A + O + G \\ &= 180 + 110 + 450 + 900 \\ F_a &= 1640 \text{ kN} \end{aligned}$$

$$\begin{aligned} M_k &= Q \cdot l_{\max} + A \cdot a_{\max} + W \cdot r - O \cdot o - G \cdot g \\ &= 180 \cdot 19 + 110 \cdot 9 + 27 \cdot 6.5 - 450 \cdot 0.75 - 900 \cdot 3 \\ M_k &= 1548 \text{ kNm} \end{aligned}$$

2) Load case incl. 25 % test load without wind

$$\begin{aligned} F_a &= Q \cdot 1.25 + A + O + G \\ &= 225 + 110 + 450 + 900 \\ F_a &= 1685 \text{ kN} \end{aligned}$$

$$\begin{aligned} M_k &= Q \cdot 1.25 \cdot l_{\max} + A \cdot a_{\max} - O \cdot o - G \cdot g \\ &= 225 \cdot 19 + 110 \cdot 9 - 450 \cdot 0.75 - 900 \cdot 3 \\ M_k &= 2227.5 \text{ kNm} \end{aligned}$$

3) Maximum operating load without wind

$$F_a = 1640 \text{ kN}$$

$$\begin{aligned} M_k &= Q \cdot l_{\max} + A \cdot a_{\max} - O \cdot o - G \cdot g \\ &= 180 \cdot 19 + 110 \cdot 9 - 450 \cdot 0.75 - 900 \cdot 3 \\ M_k &= 1372.5 \text{ kNm} \end{aligned}$$

When selecting the bearing, load case 2) should be used for static evaluation, and load case 3) for service life.

The static load capacity of the bearing, taking into account load factor $f_{\text{stat.}} = 1.45$, is checked against the "static limiting load curve", reference load:

$$\begin{aligned} \text{Load case 2)} \quad F_a' &= 1685 \text{ kN} \cdot 1.45 = 2443.3 \text{ kN} \\ M_k' &= 2227.5 \text{ kNm} \cdot 1.45 = 3230.0 \text{ kNm} \end{aligned}$$

A load factor of $f_L = 1.7$ is used for an overall service life of 150 000 revolutions under full load, reference load:

$$\begin{aligned} \text{Load case 3)} \quad F_a' &= 1640 \text{ kN} \cdot 1.7 = 2788 \text{ kN} \\ M_k' &= 1372.5 \text{ kNm} \cdot 1.7 = 2333.3 \text{ kNm} \end{aligned}$$

Number of bolts and strength class will be determined for maximum load without a factor:

$$\begin{aligned} \text{Load case 2)} \quad F_a &= 1685 \text{ kN} \\ M_k &= 2227.5 \text{ kNm} \end{aligned}$$

Reference loads for cargo service (*black*), grab service (*red*)

For the above-mentioned load cases, the following bearings may be selected:

e.g. bearings acc. to drawing No. 011.35.2620 with external gear see Page 64, curve ⑭; grab operation requires service life evaluation

Static limiting load curves

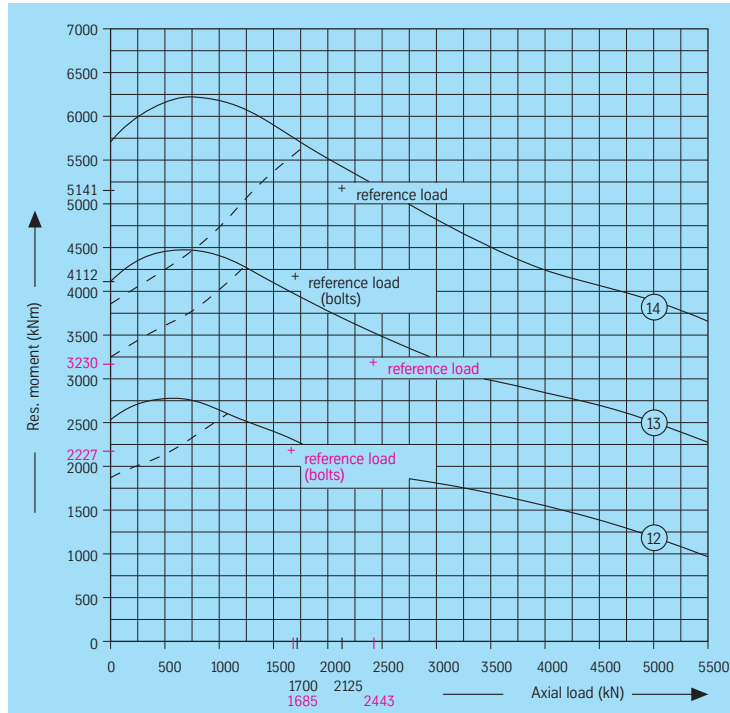

Service life curves · 30,000 revolutions

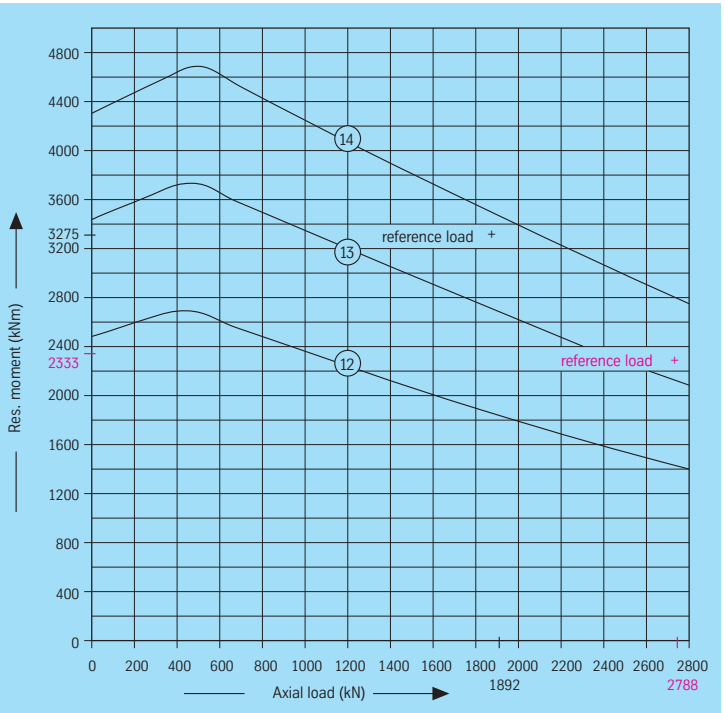

e.g. Bearings acc. to drawing No. 012.35.2690 with internal gear see Page 76, curve ④⑩; for cargo service

e.g. Bearings acc. to drawing No. 012.35.2500 with internal gear see Page 76, curve ⑤⑨; for grab service

Static limiting load curves

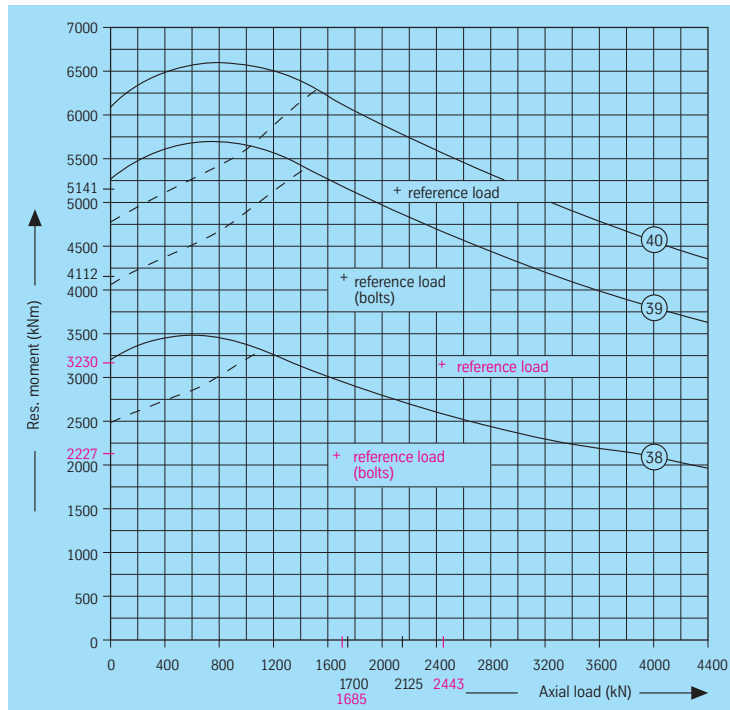

Service life curves · 30,000 revolutions

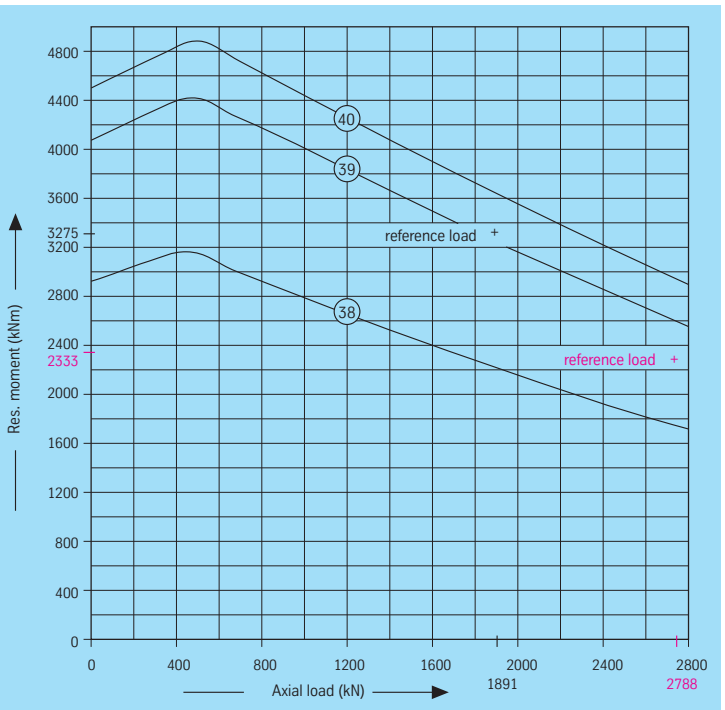

Service life.



In antifriction bearing technology, theoretical life is a well-known term. Due to a multitude of influential factors, nominal life acc. to DIN/ISO 281 cannot in practice be taken as an absolute value but as a *reference value* and design guide. Not all bearings will reach their theoretical life, although most will generally exceed it, often by several times.

Theoretical life criteria cannot be applied directly to large-diameter bearings, particularly with bearings performing intermittent slewing motions or slow rotations.

In most applications the speed of rotation in the race will be relatively low. Therefore, the smooth operation and precise running of the bearing are not adversely influenced by wear or by the sporadic occurrence of pittings. It is, therefore, not customary to design large-diameter bearings destined for slewing or slow rotating motion on the basis of their theoretical life. For better definition, the term "service life" was introduced. A bearing has reached its service life when torque resistance progressively increases, or when wear phenomena have progressed so far that the function of the bearing is jeopardized (see Page 36).

Large diameter antifriction bearings are used in highly diverse operating conditions. The modes of operation can be entirely different such as slewing over different angles, different operating cycles, oscillating motions, or continuous rotation. Therefore, apart from static aspects, these dynamic influences have to be taken into account.

The service life determined with the aid of the curves shown is only valid for bearings carrying out oscillating motions or slow rotations. This method is not applicable to:

- bearings for high radial forces,
- bearings rotating at high speed,
- bearings having to meet stringent precision requirements.

In such cases Rothe Erde will carry out the calculations based on the load spectra including the speed of rotation and the percentage of operating time.

We must clearly distinguish between the operating hours of the equipment and the actual rotating or slewing time. The various loads

must be taken into account in the form of load spectra and percentages of time. For service life considerations another influential factor not to be neglected is the slewing angle under load and without load.

For an approximate determination of the service life of a bearing, service life curves are shown next to the static limiting load diagrams. This does not apply to profile bearings types 13 and 21.

These service life curves are based on 30,000 revolutions under full load. They can also be employed to determine the service life with different load spectra or to select a bearing with a specified service life.

Symbols used	Unit		
G	U	Service life expressed in revolutions	
G ₁ ; G ₂ ; ...G _i	U	Service life for load spectra 1; 2; ...i	
F _a	kN	Axial load	
M _k	kNm	Tilting moment	
F _{ao}	kN	Axial load on the curve	
M _{ko}	kNm	Resulting tilting moment on the curve	
F _a '	kN	"Reference load" determined with f _L	
M _k '	kNm	"Reference load" determined with f _L	
F _{am}	kN	Mean axial load	
M _{km}	kNm	Mean tilting moment	
ED ₁ ; ED ₂ ; ...ED _i	%	Percentage of operating time	
p		Exponent	
		Ball bearings	p = 3
		Roller bearings	p = 10/3
$f_L = \frac{F_{ao}}{F_a} = \frac{M_{ko}}{M_k}$		Loads/curve ratio (Load factor)	[1]
$G = (f_L)^p \cdot 30\,000$			[2]

Example of a service life calculation.



Example 1

A bearing according to drawing No. 011.35.2220 is subjected to the following loads

$$F_a = 1250 \text{ kN}$$

$$M_k = 2000 \text{ kNm}$$

What is its expected service life?

Bearing and diagram, see Page 64 and curve ⑬

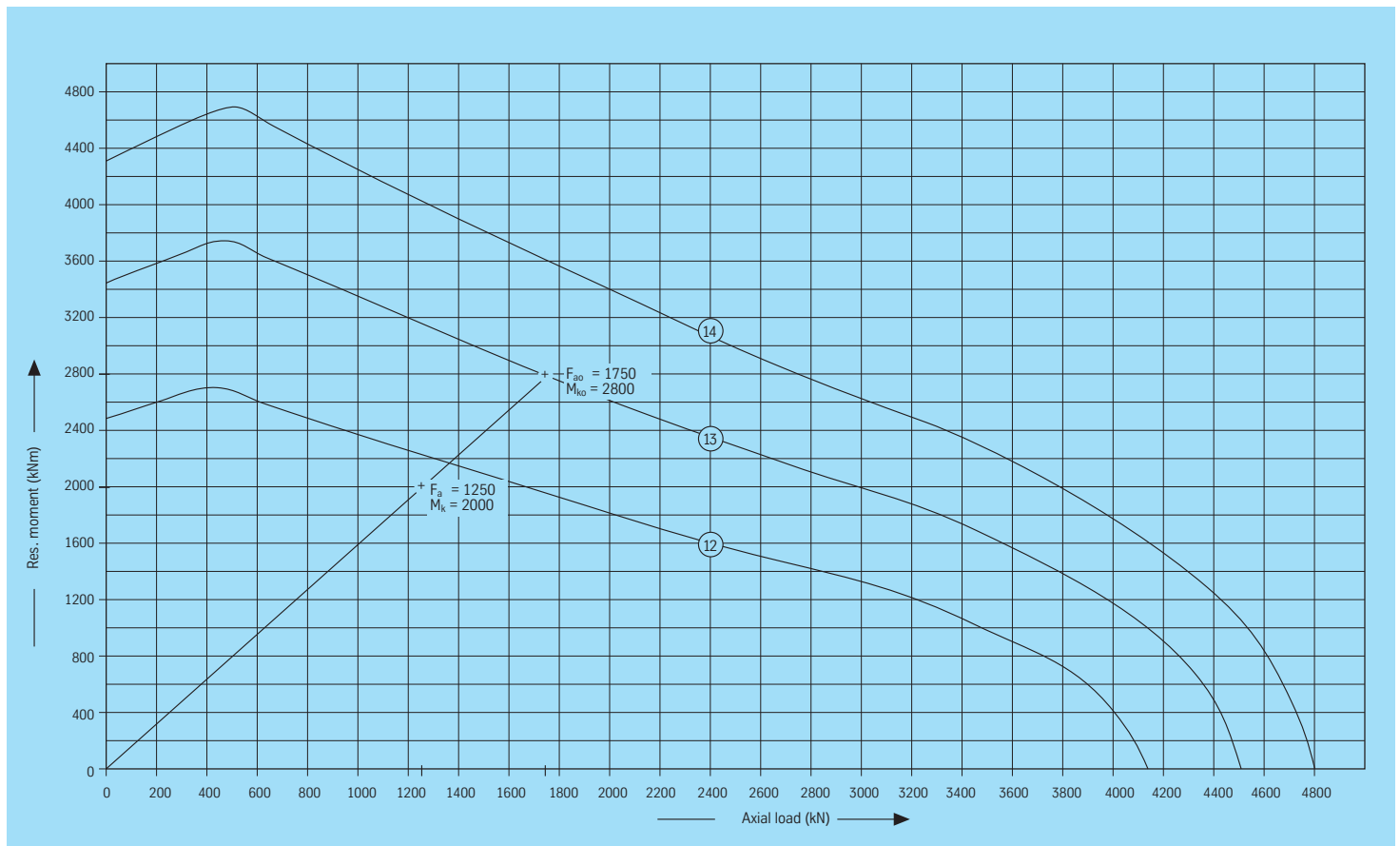

The known load case F_a and M_k is plotted on the respective diagram. The line from the zero point of the diagram through the given load case intersects the curve of the bearing, in this example 011.35.2220..., at point $(F_{ao}; M_{ko})$.

Using formulae [1] and [2] this will give

$$f_L = \frac{F_{ao}}{F_a} = \frac{M_{ko}}{M_k} \quad [1]$$

$$f_L = \frac{1750}{1250} = 1,4; \quad f_L = \frac{2800}{2000} = 1,4$$

$$G = (f_L)^3 \cdot 30\,000 \quad [2]$$

$$G = 1,4^3 \cdot 30\,000 = 82\,320 \text{ revolutions}$$

Conversion into time can be obtained via slewing or rotation angle per time unit.

If several different load combinations can be defined, example 2 should be followed to determine the operating life.



Example 2

The following load spectra are assumed for the bearing in example No. 1:

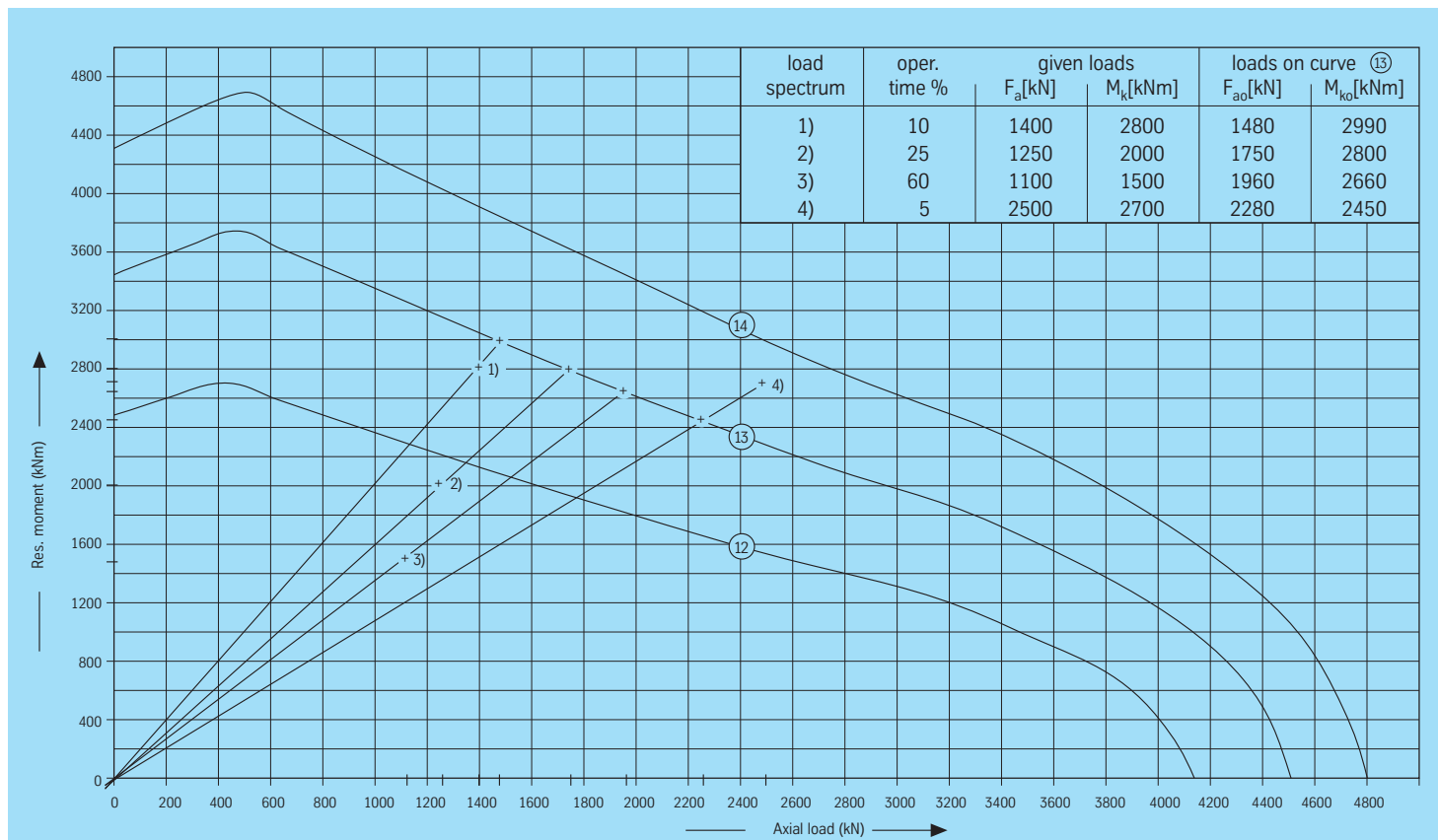

First the service life $G_{1;2;\dots;i}$ is determined for each load case according to the above diagram.

Then these values and the operating percentages given for the individual load cases are compiled into an overall service life using formula [3].

$$G_{ges} = \frac{100}{\frac{ED_1}{G_1} + \frac{ED_2}{G_2} + \dots + \frac{ED_i}{G_i}} \quad [3]$$

$$1) f_L = \frac{2990}{2800} = 1.07 \quad f_L = \frac{1480}{1400} = 1.06$$

used in calculation $f_L = 1.06$

$$2) f_L = \frac{2800}{2000} = 1.40 \quad f_L = \frac{1750}{1250} = 1.40$$

used in calculation $f_L = 1.40$

$$3) f_L = \frac{2660}{1500} = 1.77 \quad f_L = \frac{1960}{1100} = 1.78$$

used in calculation $f_L = 1.77$

$$4) f_L = \frac{2450}{2700} = 0.91 \quad f_L = \frac{2280}{2500} = 0.91$$

used in calculation $f_L = 0.91$

Summarization:

$$G_1 = 1.06^3 \cdot 30\,000 = 35\,730 \text{ U}; ED_1 = 10\%$$

$$G_2 = 1.40^3 \cdot 30\,000 = 82\,320 \text{ U}; ED_2 = 25\%$$

$$G_3 = 1.77^3 \cdot 30\,000 = 166\,360 \text{ U}; ED_3 = 60\%$$

$$G_4 = 0.91^3 \cdot 30\,000 = 22\,607 \text{ U}; ED_4 = 5\%$$

$$G_{ges} = \frac{100}{\frac{10}{35730} + \frac{25}{82320} + \frac{60}{166360} + \frac{5}{22607}} = 85807 \text{ revolutions}$$

Fastening bolts.



Bolts

The critical load curves shown in the static diagrams relate to strength class 10.9 bolts with a clamping length of $5 \cdot d$ and prestressed to 70% of the yield point.

For bearings without indicated bolt curves, the entire load capacity range below the critical load curves is covered by strength class 10.9 bolts.

Analysis of the bolt curves must be based on the maximum load without factors.

Our technical quotation will show the number of bolts, strength class and required prestress for the bearing concerned and the loads indicated. Unless mentioned otherwise, the following shall be assumed:

- a) The axial load F_a is supported, i.e. the axial operating force F_A from the axial load does not exert any tensile stress on the bolts, see figures 4 and 5.
- b) The bolts are equispaced around the hole circles.

- c) The mating structures are meeting our technical requirements, see Page 32.
- d) Bearing and mating structures consists of steel.
- e) No resin grouting provided.
- f) The clamping length l_k is at least $5 \cdot d$ for bearings with a fully annular cross section and at least $3 \cdot d$ for profiled bearings, e.g. KD 210 type series.
- g) There are at least six free threads available in the loaded bolt section.

The angularity between support and bolt/nut thread axes must be checked.

Pitch errors which will falsify the tightening torque and lead to lower bolt prestress forces, especially if the reach is $> 1 \cdot d$, must be avoided.

Where deviations in these conditions occur, prior consultation with us will be required.

In order to avoid prestress losses due to creeping, the surface pressures shown in Table 3 (see Page 19) in the contact areas between bolt head and nut/material of the clamped parts should not be exceeded.

The selected product and strength classes of bolts and nuts must be guaranteed by the manufacturer to DIN/ISO standards.

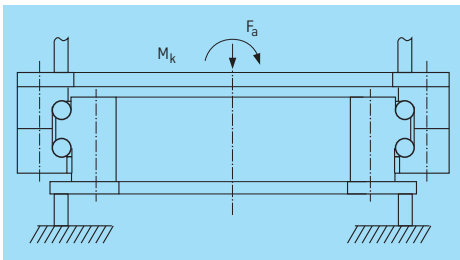

Fig. 4: Axial load "compressive"

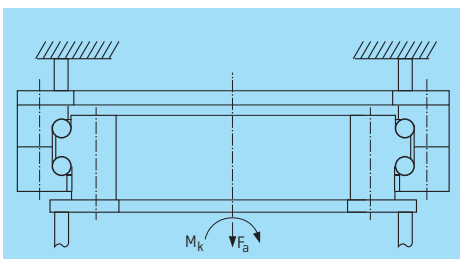

Fig 5: Axial load "suspended"

Table 2: Minimum engagement for blind hole threads. Applies to medium tolerance class (6 H)

Deviating tolerance classes require specific insertion lengths

Bolt strength class	8.8	8.8 10.9	10.9 12.9	12.9	d – Thread O.D. [mm]
Rate of thread d/P	< 9	$\geq 9 < 9$	$\geq 9 < 9$	≥ 9	Bolts with metric ISO-thread (standard thread)
St 37	$1.0 \cdot d$	$1.25 \cdot d$			P – Pitch [mm] up to M 30 = $d/P < 9$ > M 30 = $d/P \geq 9$
St 50, C 45 N, 46 Cr 2 N, 46 Cr 4 N	$0.9 \cdot d$	$1.0 \cdot d$	$1.2 \cdot d$	$1.4 \cdot d$	
C 45 V, 46 Cr 4 V, 42 CrMo 4 V	$0.8 \cdot d$	$0.9 \cdot d$	$1.0 \cdot d$	$1.1 \cdot d$	

Table 4 does not show any tightening torques for bolts > M 30, as experience has shown that their friction coefficients vary too much. These bolts should preferentially be tightened using a hydraulic tension cylinder, see Page 20.

The increased space requirement for bolt head, nut and tightening tool must be taken into account as early as possible during the design phase. The thickness of the washer must be adapted to the bolt diameter. Observe plane-parallelism.

Approximate determination of surface pressure underneath the bolt head or nut contact area.

Conditions:

$$p = \frac{F_M/0.9}{A_p} \leq p_G$$

F_M – Mounting prestressing force for selected bolt [N]

A_p – Contact area under bolt head or nut [mm²]

p_G – Limiting surface pressure [N/mm²] for the pressed parts

With hexagon head bolts, the reduced contact area due to hole chamfer and seating plate must be taken into consideration.

$$A_p = \frac{\pi}{4} (d_w^2 - d_h^2)$$

for $d_h > d_a$

d_h – Bore diameter

d_a – I.D. of head contact area

d_w – O.D. of head contact area

Tightening torque

The tightening torque is dependent on many factors, in particular however on the friction value in the thread, as well as on the head respectively the nut contact area.

For a medium friction value of $\mu_G \approx \mu_K = 0.14$ (threads and contact surface is lightly oiled) the tightening torque M_A to pre-load F_M for the hydraulic torque wrench is indicated.

Considering a divergence of $\pm 10\%$ the assembly torque M_A' has been determined for the torque spanner.

Table 3: p_G - Limiting surface pressure [N/mm²] for the pressed parts

Material	p_G Limiting surface pressure
St 37	260 N/mm ²
St 50, C 45 N, 46 Cr 2 N, 46 Cr 4 N	420 N/mm ²
C 45, profile rolled (KD 210)	700 N/mm ²
C 45 V, 46 Cr 4 V, 42 CrMo 4 V	700 N/mm ²
GG 25	800 N/mm ²

If these surface pressures are exceeded, washers of respective sizes and strengths must be provided.

Table 4: Clamping forces and tightening torques for bolts with metric regulation threads DIN 13, for $\mu_G \approx \mu_K = 0.14$

Strength class to DIN/ISO 898			8.8			10.9			12.9		
Yield limit $R_{p0.2}$ N/mm ²			640 for \leq M 16 660 for $>$ M 16			940			1100		
Metric ISO-thread DIN 13	stress area Tension A_s mm ²	Core cross-section A_3 mm ²	Clamping force F_M N	For hydr. and electric torque wrench M_A Nm	$M_a' = 0.9 M_D^*$ for spanner M_A' Nm	Clamping force F_M N	For hydr. and electric torque wrench M_A Nm	$M_a' = 0.9 M_D^*$ for spanner M_A' Nm	Clamping force F_M N	For hydr. and electric torque wrench M_A Nm	$M_a' = 0.9 M_D^*$ for spanner M_A' Nm
M 12	84.3	76.2	38500	87	78	56000	130	117	66000	150	135
M 14	115	105	53000	140	126	77000	205	184	90000	240	216
M 16	157	144	72000	215	193	106000	310	279	124000	370	333
M 18	193	175	91000	300	270	129000	430	387	151000	510	459
M 20	245	225	117000	430	387	166000	620	558	194000	720	648
M 22	303	282	146000	580	522	208000	830	747	243000	970	873
M 24	353	324	168000	740	666	239000	1060	954	280000	1240	1116
M 27	459	427	221000	1100	990	315000	1550	1395	370000	1850	1665
M 30	561	519	270000	1500	1350	385000	2100	1890	450000	2500	2250
M 33	694	647	335000	determined bolt through yield measurement		480000	determined bolt through yield measurement		560000	determined bolt through yield measurement	
M 36	817	759	395000			670000			600000		
M 39	976	913	475000			772000			790000		
M 42	1120	1045	542000			905000			904000		
M 45	1300	1224	635000			1018000			1059000		
M 48	1470	1377	714000			1221000			1191000		
M 52	1760	1652	857000			1408000			1429000		
M 56	2030	1905	989000			1647000			1648000		
M 60	2360	2227	1156000						1927000		

* = M_A will change with deviating μ_G or μ_K



Prestressing of fastening bolts by hydraulic tension cylinder (Stretch method)

Tests and practical experience have shown time and again that the calculated torques for bolts $> M 30$ or $1\frac{1}{4}$ " are not coinciding with the actual values with adequate precision.

The main influential factor for these differences is thread friction in the bolt and nut contact area, for which to a large extent only empirical or estimated values are available. The effective friction force is determined by the friction coefficient. In addition, a bolted connection will undergo settling which is predominantly caused by the smoothing out of surface irregularities.

As these factors are of considerable importance in calculating the tightening torque, they can lead to substantial bolt stress variations.

The following lists of factors influencing friction coefficient variations are to illustrate this uncertainty:

1) Thread friction is a function of:

- the roughness of the thread surface i.e. the way how the thread is produced, whether cut or rolled
- surface roughness, i.e. bright, phosphated or blackened;
- type of lubrication: dry, lightly oiled, heavily oiled;
- surface treatment of the mother thread;
- inserted thread length;
- possibly repeated tightening and loosening of the bolts.

2) Friction variations between head or nut contact area are a function of:

- roughness of the contact surfaces;
- surface condition (dry, lubricated, painted);
- hardness differences between the contact surfaces or material pairing;
- dimensional and angular deviations between contact surfaces.

The factors influencing the bolt stress can most effectively be reduced by using hydraulic tension cylinders, especially in the case of larger-diameter bolts. Compared with the conventional torque method, the tension cylinder offers the advantage of eliminating the additional torsional and bending stresses over the bolt cross section. Even more decisive is the lack of any type of friction which allows to precisely determine the remaining bolt prestress by previous tests, taking into account respective design parameters.

It is possible to calculate with a tightening factor of a_A of 1.2 to 1.6, depending on the diameter/length ratio, and to use the yield point of the bolt up to 90%. The prestress of the bolt tightened first is influenced by the tightening of the other bolts so that a minimum of two passes is required.

This will at the same time compensate for the settling produced by the smoothing out of the unloaded mating surface during prestressing (thread and nut contact area).

Table 7 shows the theoretical tension forces for a selected bolt series.

Due to the non-parallelism between nut and contact area and the thread tolerance, settling phenomena after the nut has been tightened cannot be included by this method either. (It is recommended to request the bolts and nuts manufacturer to observe strict squareness tolerances.)

As the tension force applied in this method will not only cause elongation in the shaft but also in the thread, it is important to choose the correct thread series or thread tolerances acc. to DIN 2510. An inadequate thread clearance may cause jamming of the nut, when the bolt is elongated. Taking into account the nut height consultation with the bolts manufacturer is absolutely necessary.

The bolts should be long enough to leave at least $1 \cdot d$ above the nuts free for positioning the tension cylinder.

The exact minimum length will depend on the strength class of the bolts and the tensioning tool used. Washers should be large enough to be pressed onto contact surface by the tension cylinder during bolt tightening. Enlarged washers should be preferred over standardised washers. Consultation with the tension cylinder supplier is necessary.

Hydraulic tension cylinders often require more space than torque spanners, because the entire device must be positioned in the bolt axis.

We recommend to use bolt tension cylinders by **ITH** GmbH, Auf'm Brinke 18, D-59872 Meschede, Germany. The following tables show the tension forces and dimensions for single and multistage bolt tension cylinders.

Torque spanners for bolts requiring torque-type prestressing can also be obtained from **ITH**.

Information available upon request.

Table 5: Bolt Tensioning Cylinder type ES, property class 10.9

type	Order-no.	tensioning force in kN**	thread size \varnothing^*	D_3	D_4	H_1		H_3
						min.	max.	
ES 20	33.02640	200	M 20	60	65	40	65	121
ES 24	33.02641	290	M 24	64	78	50	75	130
ES 27	33.02642	380	M 27	67	86	54	75	119
ES 30	33.02643	460	M 30	74	97	60	83	131
ES 33	33.02644	570	M 33	79	106	66	92	136
ES 36	33.02645	670	M 36	89	117	78	132	152
ES 39	33.02646	800	M 39	97	125	78	110	138
ES 42	33.02647	920	M 42	104	134	84	119	143
ES 45	33.02648	1080	M 45	113	148	86	125	147
ES 48	33.02649	1220	M 48	113	158	96	149	171
ES 52	33.02650	1450	M 52	129	170	104	135	163
ES 56	33.02651	1680	M 56	135	181	112	146	181
ES 64	33.02653	2210	M 64	154	210	128	159	195
ES 72	33.02655	2880	M 72 x 6	164	239	144	168	203

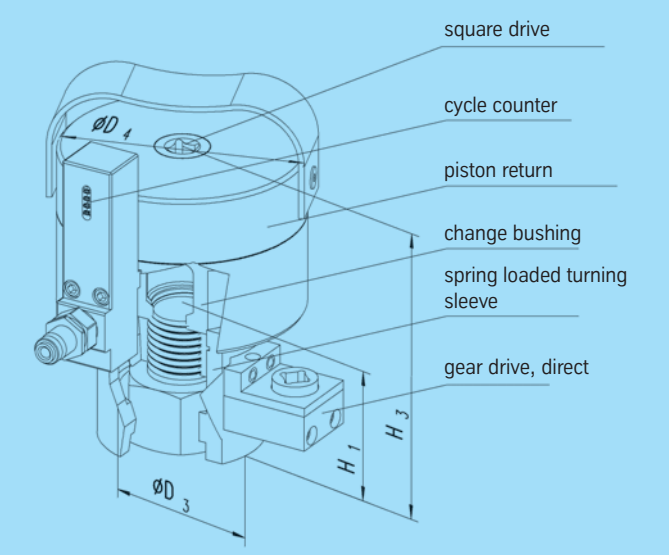

* additional sizes on request

** The tensioning forces are valid for strength class 10.9, using 90 % of the 0.2 elongation limit. If higher tensioning forces are required, the next largest cylinder (e.g. ES 42 instead of ES 39) or a special design should be used.

Table 6: Bolt Tensioning Cylinder type MS, property class 10.9

type	Order-no.	tensioning force in kN**	thread size \varnothing^*	D_3	D_4	H_1		H_3
						min.	max.	
MS 20	33.40090	200	M 20	47	47	40	47	169
MS 24	33.40091	290	M 24	62	60	50	63	200
MS 27	33.40092	380	M 27	65	65	57	68	210
MS 30	33.40093	460	M 30	72	72	62	72	204
MS 33	33.40094	570	M 33	77	79	62	72	216
MS 36	33.40095	670	M 36	83	83	71	91	250
MS 39	33.40096	805	M 39	90	91	74	93	265
MS 42	33.40097	920	M 42	98	98	80	104	272
MS 45	33.40098	1080	M 45	106	106	83	101	273
MS 48	33.40099	1220	M 48	112	112	90	105	290
MS 52	33.40100	1450	M 52	123	123	108	130	336
MS 56	33.40101	1684	M 56	131	131	117	145	356
MS 64	33.40103	2210	M 64	150	150	132	145	357
MS 72	33.40105	2880	M 72 x 6	168	168	147	170	406

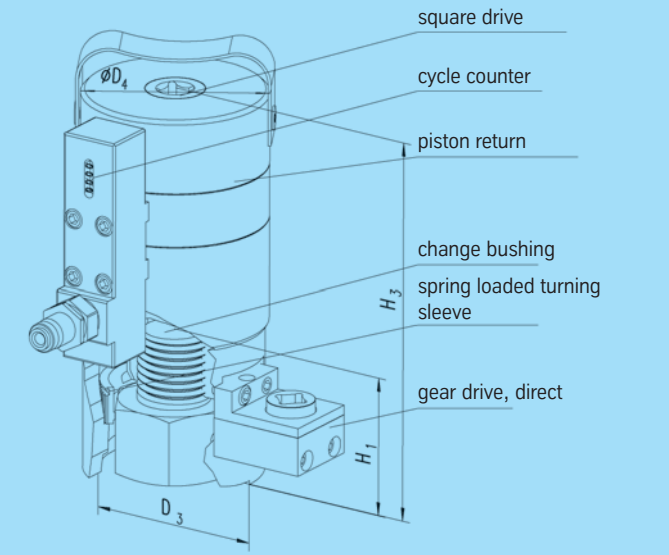

* additional sizes on request

** The tensioning forces are valid for strength class 10.9, using 90 % of the 0.2 elongation limit. If higher tensioning forces are required, the next largest cylinder (e.g. MS 42 instead of MS 39) or a special design should be used.



**Table 7: Bolt tension forces including tolerances for “large-clearance metric thread”
– DIN 2510 – Sheet 2 – using hydraulic tension cylinders**

Strength class to DIN/ISO 898				8.8		10.9	
Yield point $R_{p0,2}$ N/mm ²				660		940	
		Tolerances to DIN 2510		Tension force at yield point $F_{0,2}$ N	Theoretical use of tension force $F_M = 0,9 \cdot F_{0,2}$ N	Tension force at yield point $F_{0,2}$ N	Theoretical use of tension force $F_M = 0,9 \cdot F_{0,2}$ N
Metric ISO-Thread DIN 13	Nominal dia. mm	Tension cross-section A_s mm ²	Core cross-section A_3 mm ²				
	Pitch mm						
16	2	148	133	94700	85200	139100	125200
20	2.5	232	211	153000	137000	218000	196000
24	3	335	305	221000	199000	315000	283000
27	3	440	404	290000	261000	413000	372000
30	3.5	537	492	354000	319000	504000	454000
33	3.5	668	617	440000	396000	627000	564000
36	4	786	723	518000	466000	738000	664000
39	4	943	873	622000	559000	886000	797000
42	4.5	1083	999	714000	642000	1018000	916000
45	4.5	1265	1174	834000	750000	1189000	1070000
48	5	1426	1320	941000	846000	1340000	1206000
52	5	1707	1590	1126000	1013000	1604000	1443000
56	5.5	1971	1833	1300000	1170000	1852000	1666000
64	6	2599	2426	1715000	1543000	2443000	2198000
72	6	3372	3174	2225000	2002000	3169000	2852000
80	6	4245	4023	2801000	2520000	3990000	3591000
90	6	5479	5226	3616000	3254000	5150000	4635000
100	6	6858	6575	4526000	4073000	6446000	5801000

Determination of tightening torques for fastening bolts > M 30 or 1 1/4“

Tightening torque variations can be considerably reduced if the tightening torque for bolts > M 30 or 1 1/4“ is not theoretically determined but by the longitudinal elongation of the bolt.

This procedure can be easily performed if both bolt ends are accessible in the bolted condition. Structures not allowing this will require a model test (Fig. 7, Page 23).

The equivalent clamping length must be simulated by identically dimensioned steel blocks. The condition of the surface underneath the turned part (bolt head or nut) should also be identical with the object itself. Generally hardened and tempered washers are used, so that these conditions can be easily complied with. The influence of a different number of joints is hardly measurable and can therefore be neglected.

The expected standard variation must be taken into account in the calculation of the tightening torque. The test is to assure that the minimum clamping force of these larger bolts is within the values assumed in the calculation.

For the bolt to be used, the elastic longitudinal elongation at 70 % prestress of the yield point is determined theoretically via the elastic resilience of the bolt with respect to its clamping length.

The bolt is prestressed until the previously determined bolt elongation Δl is displayed on the dial gauge. This torque is then read off the torque spanner. To account for any variations, an average value from several measurements should be determined.

When using a torque spanner with wrench socket, the measuring caliper must be removed during tightening of the nut, and the test bolts should be provided with center bores at both ends in order to avoid errors due to incorrect positioning of the measuring caliper, (Fig. 6, Page 23).

All fastening bolts on the bearing are then prestressed to this tightening torque using the same torque spanner as in the test. It must be assured that the actual bolts used and the test bolts come from the same production batch.

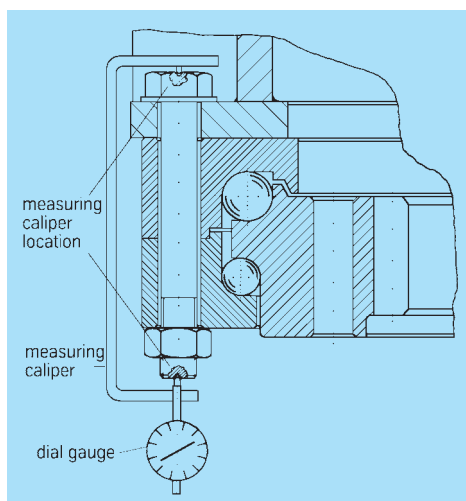

Fig. 6

After a certain operating time the bolt connection must be rechecked for prestress and retightened, if necessary. This is required to compensate for any settling phenomena which might reduce the bolt prestress.

The required longitudinal elongation is theoretically determined by the elastic resilience of the bolt.

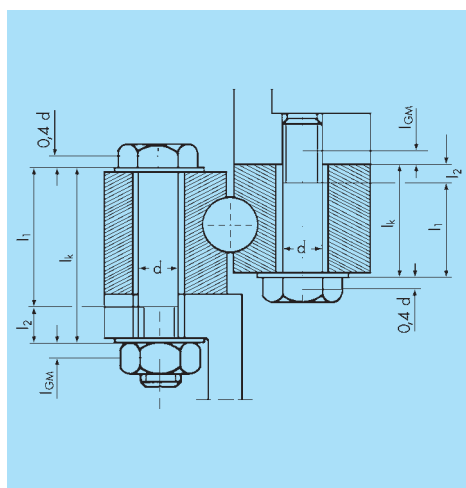

Fig. 7

Symbols used

A_N	Nominal bolt cross section	mm^2
A_3	Thread core cross section	mm^2
A_S	Bolt thread tension cross section	mm^2
E_S	Young's modulus of the bolt	$205\,000\ \text{N/mm}^2$
F_M	Mounting tension force	N
$F_{0,2}$	Bolt force at minimum yield point	N
l_1	Elastic bolt length	mm
l_2	Elastic thread length	mm
Δl	Linear deformation at bolt tightening	mm
δ_S	Elastic resilience of the bolt	mm/N
$R_{p\,0,2}$	Tension at yield point of bolt material	N/mm^2
l_k	Clamping length of the bolt	mm
l_{GM}	Thread length l_G and nut displacement l_M · $l_{GM} = l_G + l_M$ used in calculating the resilience of the inserted thread portion	mm

This gives

$$\delta = \frac{l}{E \cdot A}$$

$$\delta_S = \underbrace{\delta_K}_{\text{head}} + \underbrace{\delta_1}_{\text{shaft}} + \underbrace{\delta_2}_{\text{not inserted thread portion}} + \underbrace{\delta_{GM}}_{\text{inserted thread portion}}$$

with $l_G = 0,5\ d$ and $l_M = 0,4\ d$

for nuts ac. to DIN 934

$$\delta_S = \frac{0,4\ d}{E_S \cdot A_N} + \frac{l_1}{E_S \cdot A_N} + \frac{l_2}{E_S \cdot A_3} + \frac{0,5 \cdot d}{E_S \cdot A_3} + \frac{0,4 \cdot d}{E_S \cdot A_N}$$

The force allocated to the elastic longitudinal elongation is:

$$F_M = \frac{1}{\delta_S} \cdot \Delta l \quad [\text{N}]$$

Determination of the prestressing force using 70% of yield limit relative to the tension cross section:

$$F_M = 0,7 \cdot R_{p\,0,2} \cdot A_S \quad [\text{N}]$$

$$F_{0,2} = R_{p\,0,2} \cdot A_S \quad [\text{N}]$$

$$R_{p\,0,2} \text{ for strength class 8.8} \\ = 640\ \text{N/mm}^2 \text{ for } d \leq 16; \\ = 660\ \text{N/mm}^2 \text{ for } d > 16.$$

$$R_{p\,0,2} \text{ for strength class 10.9} \\ = 940\ \text{N/mm}^2$$

$$R_{p\,0,2} \text{ for strength class 12.9} \\ = 1100\ \text{N/mm}^2$$

Therefore:

$$\Delta l = F_M \cdot \delta_S \quad [\text{mm}]$$

Loctite-586

Improvement in the frictional bond.



Bearing installation using Loctite-586

The roughness of the surface to be joined should not exceed a value of Rt 65 (peak-to-valley height) since shear strength will decrease at greater roughness values.

Theoretically, the quantity required for a layer of 0.1 mm is 100 ml/m². However, if the layer is to be applied by hand, it is advisable to use double or triple this quantity, since dosage by hand cannot always be absolutely accurate.

The following points must be observed during installation:

- 1) Cleaning of contact surfaces with a commercially available cleaning agent to remove any oil or grease
- 2) Inactive surfaces must be pretreated with the 7471 activator. Loctite-586 must only be applied to the nonactivated surface. If both sides are active, or if Loctite is applied onto the activator, premature curing may result (drying within a few minutes).
- 3) Loctite must be applied with a stiff brush onto one surface.



- 4) Spigot locations must not come into contact with Loctite since this would render later dismantling difficult. They must be coated with a separating agent, e.g. wax or grease.
- 5) Tightening of fastening bolts. Loctite will start curing as soon as 2 hours after positioning of the bearing. If it is not possible to fully tighten the bolts during this period, manual tightening will suffice as a preliminary solution.
- 6) Through holes and tapped holes have to be protected against Loctite.

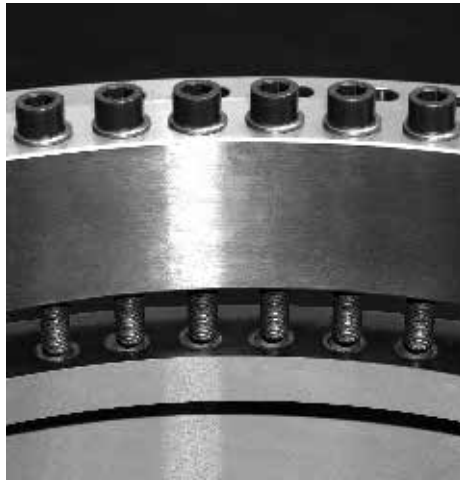

Dismantling

As already mentioned, the Loctite joint will resist compressive and shear forces, but not tension. Therefore, separating the bearing from its companion structure does not present any difficulties.

When using Loctite, the best solution is to incorporate tapped holes for jacking screws right at the design stage of the companion structure. For large and heavy bearings and/or a horizontal axis of rotation, the use of jacking screws is imperative, especially when the mounting space is restricted.

To lift the bearing off, the jacking screws are tightened consecutively until the bearing works itself free.

With smaller bearings and easily accessible mounting space, it may suffice to carefully lift the bearing at one side, e.g. by applying a pinch bar at several points around the circumference.

Under no circumstances should the bearing be suspended from eye bolts and lifted off before the joint has been released in the manner described above.

Before reassembly, the surfaces are best cleaned by means of a wire brush.

Gearing.



Rothe Erde
Slewing Bearings

Rothe Erde large-diameter bearings are in the majority of cases supplied with spur gears. A gear cut into one of the bearing rings offers the advantage that an additional driving gear wheel is not required, which helps to reduce design work and costs.

Highly stressed gear pairings require a pinion tip radius and a pinion tip relief.

Mainly provided are bearings with corrected gearing, addendum modification coefficient $x = 0.5$ see DIN 3994, 3995.

For gears subjected to high tooth flank stress, hardened gears have proven very satisfactory. Depending on module and ring diameter, the gear rings are subjected to spin hardening or individual tooth induction-hardening, the latter predominantly in the form of tooth contour hardening. Both methods provide improved flank load carrying capacity as well as higher tooth root strength. Flank hardening with hardness phase-out in the region of the root radii leaving the root radius unhardened will reduce the load capacity at the root. Hardened gears will require an individual calculation.

We need to know the pinion data in order to be able to check the meshing geometry.

During the installation of the large-diameter bearing and the drive pinion, adequate backlash must be assured.

The backlash is adjusted at 3 teeth marked in green and is to be at least $0.03 \times$ module.

After final assembly of the equipment and after tightening all of the fastening bolts, the backlash must be checked using a feeler gauge or a lead wire.

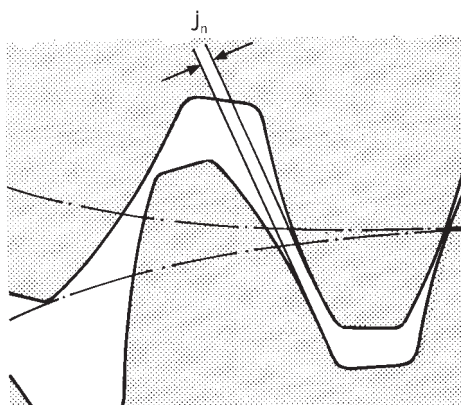

Fig. 8: Backlash

Pinion tip radius and pinion tip relief.

Despite geometrically correct profiles and theoretically adequate gears, meshing problems may still occur in highly stressed gears, e.g. “scuffing” or “chipping” at the dedendum flank of the wheel, as shown in Fig. 9.

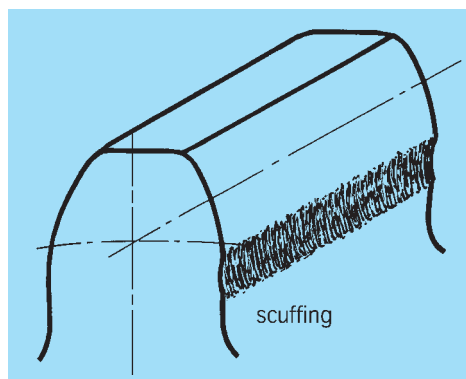

Fig. 9

This phenomenon occurs primarily in gears with hardened pinions where the tip edges of the pinion act as scrapers.

Various causes may be responsible.

Bending

Dynamic load peaks under high force applications, accelerations, braking actions or vibrations will cause elastic deformations in the meshing teeth.

Pitch errors

Manufacturing tolerances in gears cannot be prevented, especially pitch errors, which in combination with the bending effect can produce negative influences.

Drive unit

Most slewing drive units are mounted in an overhung arrangement, and deflections of the pinion shaft are unavoidable. The high forces will simultaneously produce elastic deformations at the interface of the slewing drive and mounting structure. Such deformations may also lead to meshing problems.

Lubrication

The three influential factors mentioned will result in high peak loads acting on the tip edge of the pinion, which can cause the lubricant film to break.

The direct metallic contact will increase the chipping effect.

Occasional damage which has occurred in the past, can now be prevented by providing a tip relief at the pinion and a radius at the tip edge of the pinion.

Tip relief

Tip relief has become a means of reducing the effects of vibration (noises) in high-speed gear mechanisms.

Investigations have led us to specify pinions with a tip edge radius of 0.1 – 0.15 times module for applications with extreme load conditions.

The radius must blend into the addendum flank without forming an edge.

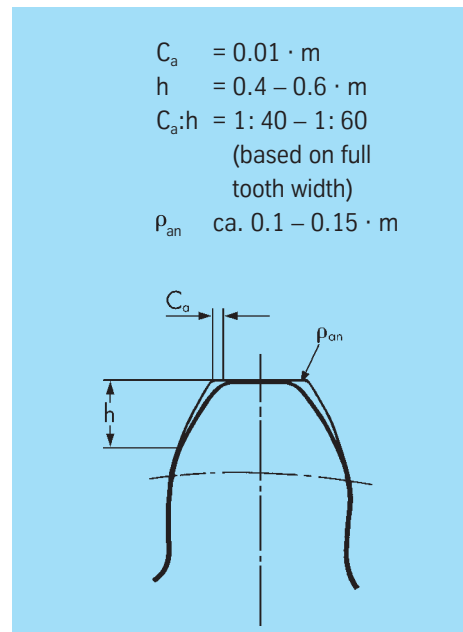

Fig. 10

Turning torque calculation.



The calculation of the torque M_r , detailed below is based on theoretical and empirical knowledge. The torque is affected by the rolling friction coefficient, the rolling elements, spacers, seals, load distribution and the load.

Some other factors affecting the torque are:

- The out-of-flatness including the slope of the upper and lower companion structure.
- The grease filling and the type of grease.
- The lubrication of the lip seals and the seal preload.
- The variation in the bearing's clearance resulting from installation.

The torque calculated is, of course, subject to certain fluctuations, which can be estimated with approx. $\pm 25\%$.

1. Starting Torque M_r

Ball bearing slewing rings

$$M_r = \frac{\mu}{2} (4.4 \cdot M_k + F_a \cdot D_L + 2.2 \cdot F_r \cdot D_L \cdot 1.73) \quad [\text{kNm}]$$

Roller bearing slewing rings

$$M_r = \frac{\mu}{2} (4.1 \cdot M_k + F_a \cdot D_L + 2.05 \cdot F_r \cdot D_L) \quad [\text{kNm}]$$

2. Power of Inertia

$$P_{\text{Beh.}} = M_r \cdot \omega \cdot \eta^{-1} \quad [\text{kNm} \cdot \text{s}^{-1}]$$

$$= \frac{M_r \cdot n}{9.55 \cdot \eta} \quad [\text{kW}]$$

Specially designed bearings with reduced torque can be supplied. Please contact us regarding the applications for such bearings.

In order to assess the total moment necessary for rotating the bearing, the acceleration power of all the individual masses must still be configured as a product using the squared distance of their centres of gravity from the axis of rotation. The strength of the wind, which may possibly act upon the bearing, and any component parts under slope must also be taken into account.

Symbols used

F_a	= axial load	[kN]
F_r	= radial load	[kN]
M_k	= resulting tilting moment	[kNm]
D_L	= bearing race diameter	[m]
μ	= friction coefficient	
ω	= angular velocity	
$\omega = \frac{\pi \cdot n}{30}$		[s ⁻¹]
n	= number of bearing revolutions per minute	[min ⁻¹]
η	= drive efficiency	

Various friction coefficients

$\mu = 0.008$ for Type KD 210 (Type 13 and 21, normal bearings)
0.006 for Type KD 210 (Type 110)
0.004 for Type KD 320
0.006 for Type KD 600
0.003 for Type RD 700
0.004 for Type RD 800
0.003 for Type RD 900

For precision bearings, bearings without clearance and preloaded bearings, the turning torque calculation has to be performed by Rothe Erde.

Raceway hardening.

The bearing types described here are provided with induction-hardened raceways. This ensures good reproducibility of hardening specifications and, therefore, consistent quality. The hardening coils used have been adapted to the various raceway designs. They are configured so as to guarantee the load capacities specified for the respective rolling element sizes.

Our patented coil shape ensures a good hardness pattern in the raceways and in the transition radii in three-row roller bearings.

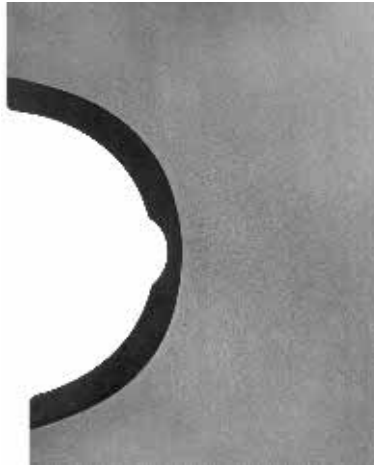

Fig. 13: Raceways in a single-row ball bearing slewing ring.

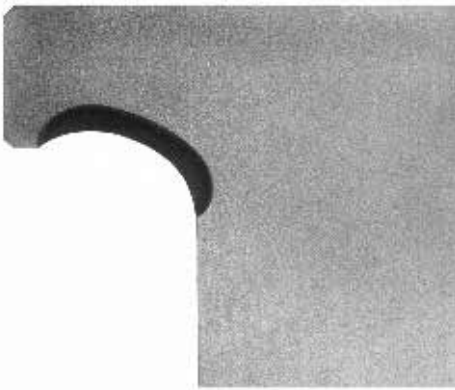

Fig. 11: Raceway of a supporting ring in a double-row ball bearing slewing ring.

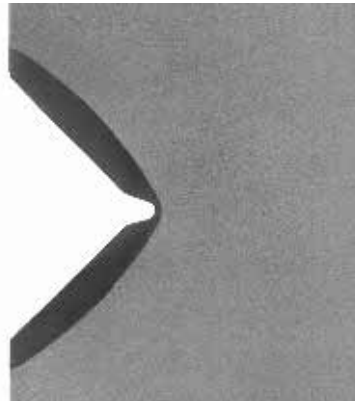

Fig. 14: Raceways in a single-row roller bearing slewing ring.

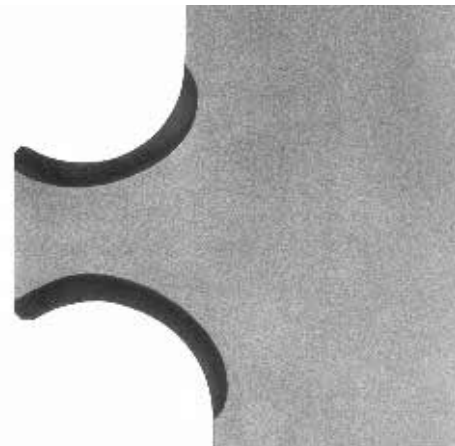

Fig. 12: Raceways of a nose ring in a double-row ball bearing slewing ring.



Fig. 15: Raceways of a nose ring in a three-row roller bearing slewing ring.



Fig. 16

Production sites both in Germany and abroad are linked by the highest levels of quality.

The integrated management system put in place at Rothe Erde includes the following elements:

- Quality assurance system acc. to DIN EN ISO 9001:2000,
- Environmental protection acc. to DIN EN ISO 14001:2004 and
- Health & safety acc. to OHSAS 18001:2007.

We must first determine whether the customer's requirements or ideas can be translated into a product that will not only meet the design criteria but will also provide a good service life.

When the requirements have been clearly defined, the desired quality level is established in collaboration with the relevant departments and incorporated in the drawings, production plans, testing instructions etc.; this also includes packing, delivery and after sales service.

An effective quality control procedure monitors and ensures the quality of the product. Based on drawings, testing plans, etc. a basis check is carried out on the parts by the operators of the machinery within their responsibility.

Moreover, members of the Quality Assurance Department carry out systematic random checks.

There is 100 % inspection of all of the production processes affecting the functioning of the product.

Material testing, i.e. the determination of mechanical properties, full analyses, structural tests, ultrasonic tests and crack tests, guarantees uniform material quality.

Should any deviations be found during quality checks, the quality assurance system prevents such defective parts from remaining in the manufacturing process.

Upon completion, every large-diameter bearing is subjected to a functional and dimensional check.

Regular computerised monitoring of the measuring equipment ensures that during the entire manufacturing and quality assurance processes, only inspected or calibrated measuring units are used.

We expect our supplier to attach the same importance to the quality of their products as we do to ours. The "goods inward" inspection

is supplemented by regular system audits of all of our suppliers. This ensures that subcontracts are granted only to those companies who have proven the quality of their products and their ability to deliver to schedule.

Internal audits in our company guarantee the quality of the manufacturing process and the functional safety of the quality assurance system. The information which these audits obtain and the data on quality which are generally stored on computer make for effective quality control.

The increasing requirements are met in our company by regular in-house training of our staff. This also serves to make our employees aware of the important contribution each individual has to make to the standard of quality.

Finite elements calculations.

The bearing rings used for slewing bearings have only a relatively large diameter in relation to their cross-sectional area. Consequently, their inherent stiffness is limited. For this reason, the supporting stiffness provided by the companion structures has a major influence on the load bearing characteristics of such a slewing bearing.

To be able to exploit the optimisation potential consistently, an integral calculation by aid of the finite elements analysis is imperative. Therefore, an optimum design is a joint task involving the slewing bearing manufacturer and the machine manufacturer.

The machine manufacturers calculate normally the adjoining companion structures by aid of finite elements models.

Defined interfaces can feed the information of the companion structures into the finite elements model of the slewing bearing enabling the calculation to consider the stiffnesses of the superstructure and of the undercarriage. Fully centralized development of an expensive overall model is no longer necessary.

This avoids the problems involved with having to interpret unfamiliar design documentation. A know how transfer does not take place.

The following part models are linked for the purpose of the analysis:

- the upper companion structure from the customer
- the slewing bearing including fastening bolts
- the lower companion structure from the customer.

The information of the part models can be easily exchanged by e-mail.

Mobile harbour crane; divided into three part models (Fig. 18)

The special software is able to directly import the files with the stiffnesses of the companion structures as generated by the customer and to add them to the model of the bearing (Fig. 18). Thus results a complete overall model with one calculation method which considers all major influence quantities simultaneously.



Mobile harbour crane; divided into three part models (Fig. 17)

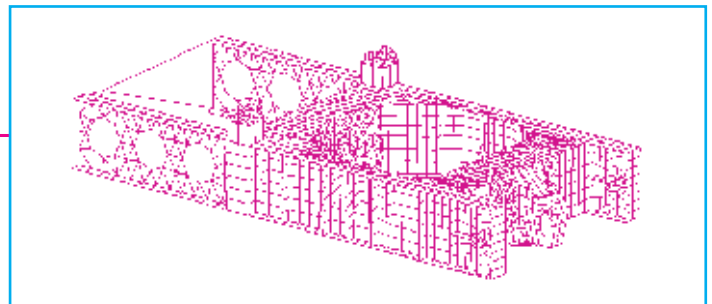

Finite elements model of the upper companion structure



Finite elements model of the slewing bearing

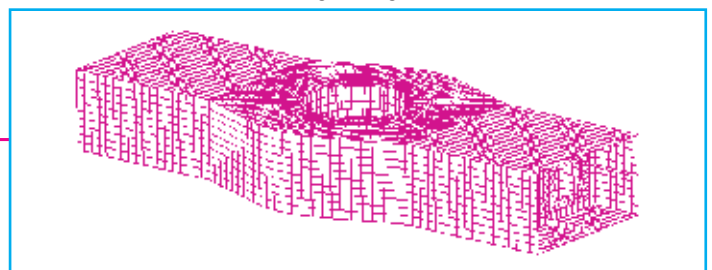

Finite elements model of the lower companion structure



Schematic of the calculation method designed by Rothe Erde

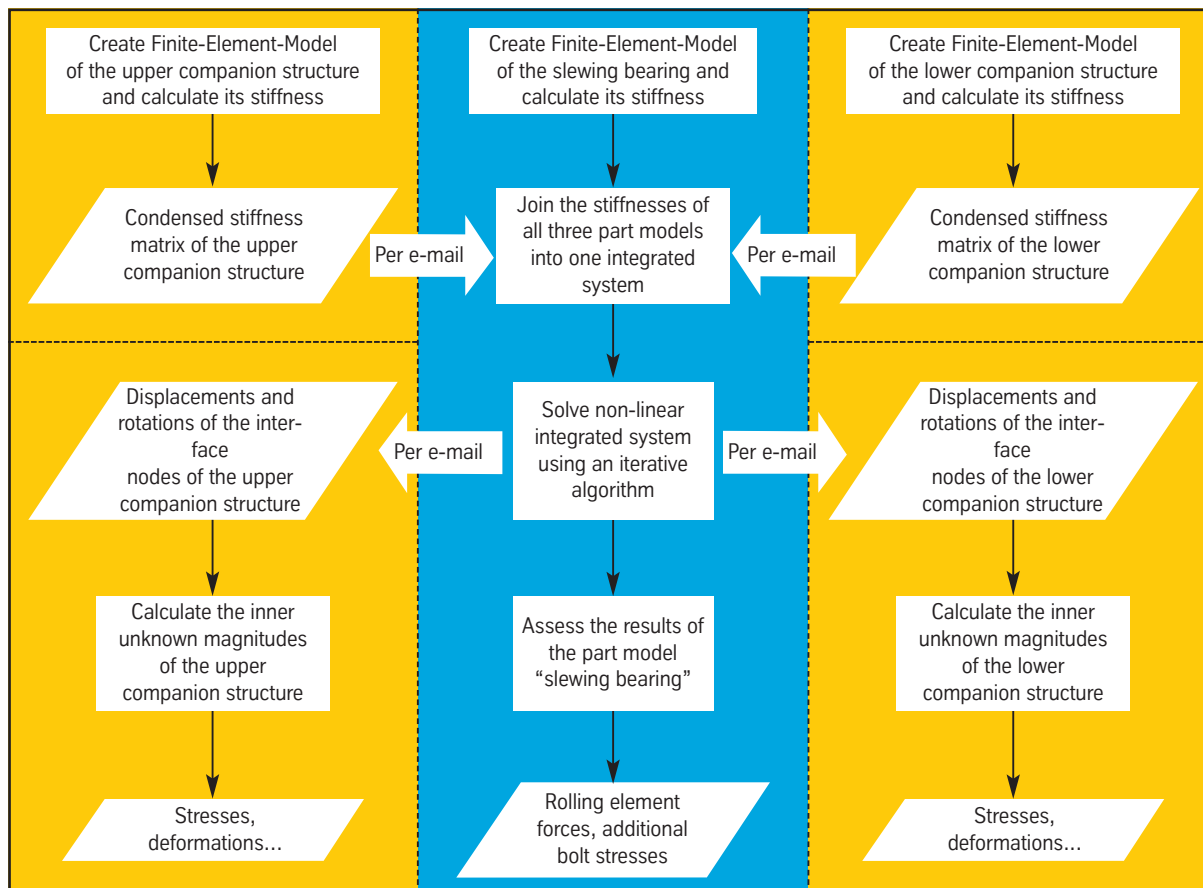

■ customer ■ Rothe Erde

Figure 18

Once the bearing calculation has been completed, the customer receives an e-mail with files containing data on the displacements and rotations of the interface nodes on the flanges of the companion structures. These data can be directly imported from his finite elements programme and used to calculate the corresponding internal stresses and deformations to which the companion structures are subject (Fig. 18). This offers an economical means of optimising prototypes in which design weaknesses can be rapidly identified.

The developed calculation method offers the customer and the manufacturer an opportunity to participate in a long-term development partnership. The new method enables both, a highly economic and a thorough analysis from the mechanical point of view.

Experiments acknowledge that the use of this system allows a very precise calculation. This in turn greatly reduces the expenditure required for prototype development.

Companion structures.



Due to their specific load carrying capacity, Rothe Erde bearings can transmit very high loads even at relatively small diameters. The bolts provided for mounting the bearing to its companion structure must be rated accordingly.

For economic reasons, the cross sections of the bearings are kept relatively low in relation to their diameters. The bearings therefore depend on a rigid and distortion-resistant structure which to a large extent will prevent deformations in the bearings under the operating loads, provided a positive bolt connection is used.

The formation of peaks in smaller sectors has to be avoided, i.e. the curve must progress gradually, rising and falling just once in the range from 0° to 90° to 180°. Otherwise tight spots may develop in the raceway which lead to local overload.

Fig. 20 illustrates that the vertical support in the companion structures must be in the vicinity of the track diameter. This is in order to keep any deflection of the support surfaces under maximum operating load within the permissible limits.

Rothe Erde offers seamless rolled rings for support structures in a multitude of cross sections and profiles, unmachined or machined to customer's drawings which, for instance for flange ring supports (e.g. angular mounting ring, Fig. 19). provide decisive advantages:

- Distortion-resistant fastening of the large-diameter bearing,
- Optimum load transfer between antifriction bearing and companion structure.

The contact surfaces for the bearing must always be flat to prevent the bearing from becoming distorted when it is bolted down. Careful machining of the contact surfaces is, therefore, absolutely essential.

As a rule, bearings and their companion structures should be connected by means of through-bolts.

Diameter tolerances of slewing bearings
Machined diameters with untoleranced drawing dimensions have the following tolerances:

≤ 315 mm	± 1,6 mm
≤ 1000 mm	± 2,5 mm
≤ 2000 mm	± 3,5 mm
≤ 4000 mm	± 5,0 mm
≤ 6300 mm	± 7,0 mm
≤ 10000 mm	± 10,0 mm



Fig. 19

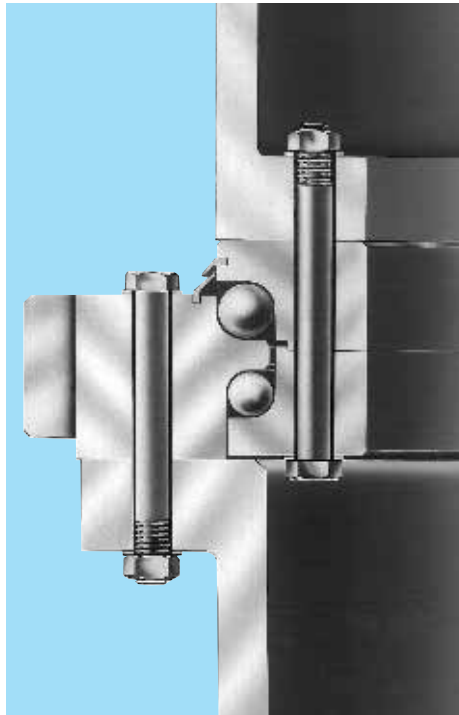

Fig. 20



Rothe Erde
Slewing Bearings

Measurement and machining of contact areas, admissible flatness deviations including slope of the companion structure.

Generally it applies that the companion structures for large antifriction bearings must not only be distortion-free but the contact surfaces for the mounting of the bearings must be as flat as possible.

Measurements of the contact areas

Before the installation of a large antifriction bearing Rothe Erde recommend that the con-

tact areas be measured by means of an optical machine or a laser measuring system. If the measured values are outside of the Rothe Erde tolerances (Table 8) Rothe Erde would recommend mechanical re-working. In some cases the re-working of spacious mating structures produces difficulties. However as a remedy we offer the use of portable processing machines (picture 21 + 23) (also for upper constructions and overhead machining).

Reputable companies can execute this work according to Rothe Erde tolerances as a local service (a reference list of these companies can be requested from Rothe Erde). The ideal installation conditions for large antifriction bearings are steel/steel contact.

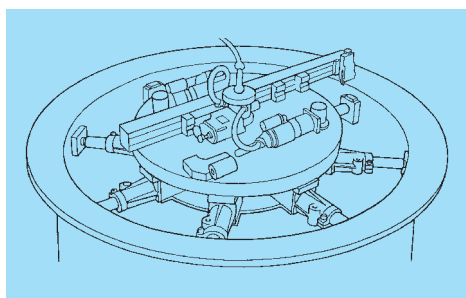

Fig. 21



Fig. 22

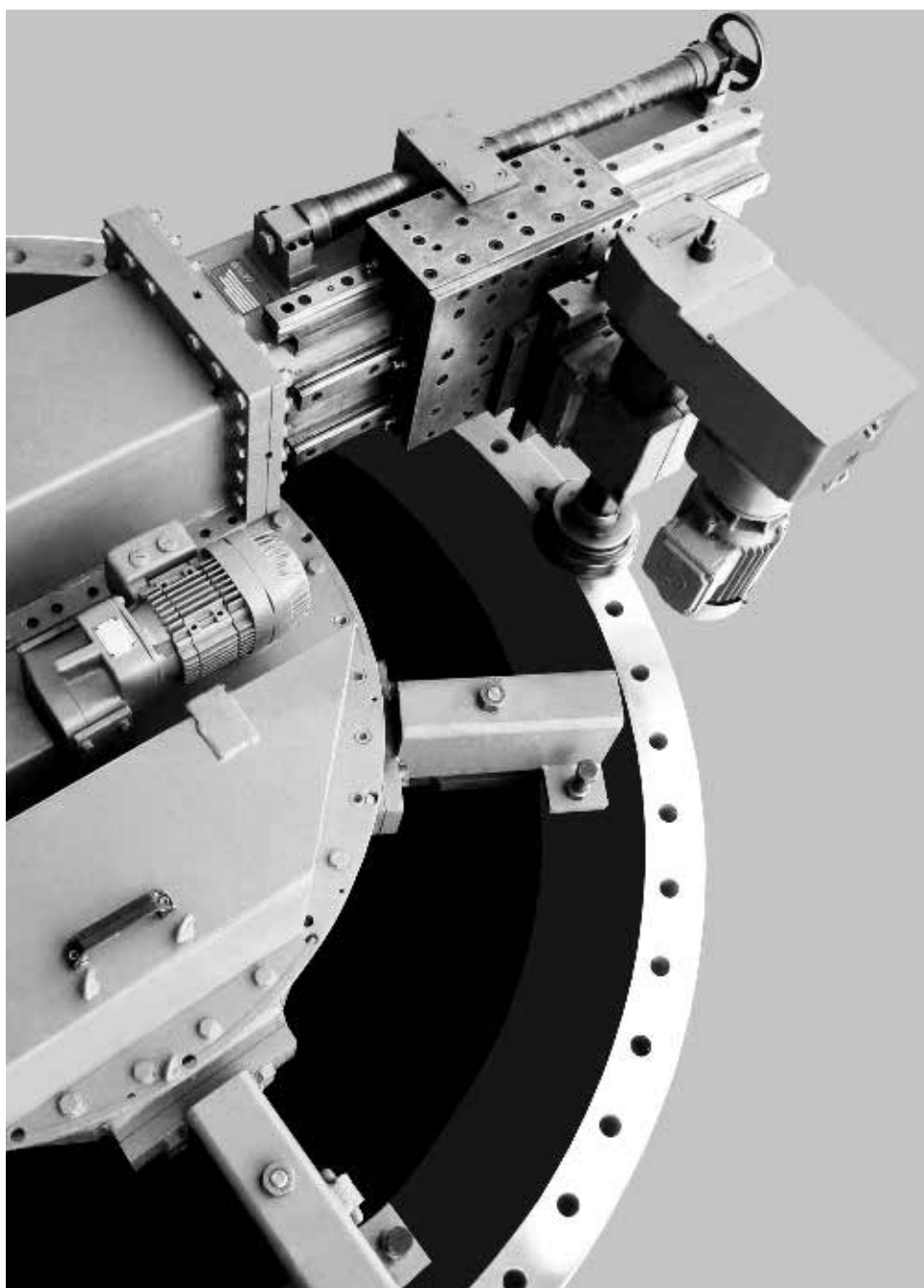

Fig. 23

Tolerated out-of-flatness including slope "P" of the machined contact surfaces for Rothe Erde Antifriction bearings.

The maximum admissible flatness deviations are listed in Table 8 as reference values.

Regarding the slope of the machined contact area the table values refer to 100 mm contact width.

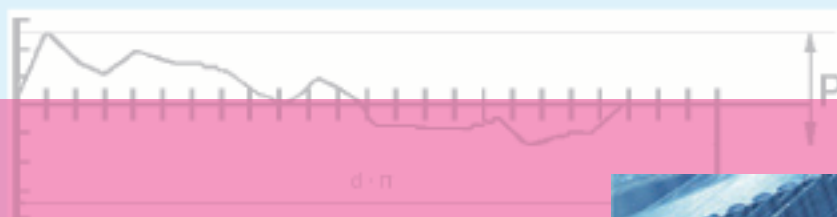

Fig. 24

You will find updated information about **admissible flatness deviations** in the brochure

Table 8:
Tolerated out-of-flatness including slope

Rothe Erde® Slewing Bearings
Installation · Lubrication · Maintenance



The link (one click) will automatically direct you to the new brochure.

Diameter D _h [mm]	Double row ball bearings		Single row ball bearings	
	to	Value	to	Value
to 500		0.15		0.15
to 1000		0.20		0.17
to 1500		0.25		0.20
to 2000		0.30	0.22	0.15
to 2500		0.35	0.25	0.17
to 4000		0.40	0.30	0.20
to 6000		0.50	0.40	0.30
to 8000		0.60	0.50	0.40

For special applications such as precision bearings with a high running accuracy and low bearing play, the values in Table 8 may not be used.

If the admissible values are exceeded, consultation should take place with Rothe Erde.

*) For normal bearing type 13 and normal bearing type 21 double values are certified.

Operating conditions and special requirements.

The data contained in this catalogue refer to oscillating motions or slow rotating movements.

It is, of course, possible to use large-diameter bearings for higher circumferential speed. For such requirements it is necessary to carry out special checks on the raceways and gears and to adapt these to the operating conditions if need be. Enquiries concerning such applications should include a description of the operating conditions as well as the customer's requirements.

If the bearing is to be installed with its axis in the horizontal position, we must be consulted beforehand.

Operating temperature

Standard design bearings are suitable for operating temperatures ranging from 253 K (-20°C) to 333 K ($+60^{\circ}\text{C}$). The various operating temperatures require suitable lubricants, see information on Page 40.

For higher or lower operating temperatures and/or temperature differences between the outer and inner rings we must be advised beforehand so that checks can be carried out. Requirements regarding the mechanical properties of the ring material are of particular importance. In many cases, for instance, a minimum notch impact strength will be required for applications at sub-zero temperatures.

Classification/special conditions

Quite a number of applications as in offshore installations and ship deck cranes require classification. For this purpose, the respective classification agencies have produced a catalogue of requirements and specify acceptance of the bearing in accordance with that document.

In order to be able to take such specifications into account when preparing our offer, we need to know the specifications in detail beforehand.

Seals

The seals provided in the bearing gaps prevent dust and small particles from directly entering the raceway and retain fresh lubricant in the bearing gaps. In this function, they have proven satisfactory under normal operating conditions for many years. With adequate relubrication, i.e. until a uniform collar of grease appears around the circumference of the bearing, their correct functioning will be assured.

In case of considerable dirt sediments appropriate covers should be provided at the companion structure.

As sealing materials are subject to ageing when exposed to a number of environmental conditions, seals require maintenance and, depending on their condition, may have to be replaced. Controlling: every 6 months.

Applications in a heavily dust-laden atmosphere, such as mechanical handling equipment for coal and ore, will require special seals. The RD 700 type series is, for instance, equipped with additional steel labyrinths at the upper bearing gaps, which have proven very satisfactory in open cast-mining. The steel labyrinth protects the seal against mechanical damage and it can be bolted in segments so that the space containing the grease can be cleaned, if necessary.

Bearings in ship deck and floating cranes are often exposed to splash and surge water. In such cases we use a special seal as shown in Fig. 25.

Installing this type of seal may increase the height of the bearing.

For the above applications it is preferable to use bearings with internal gears where the gear is protected by the surrounding structure.

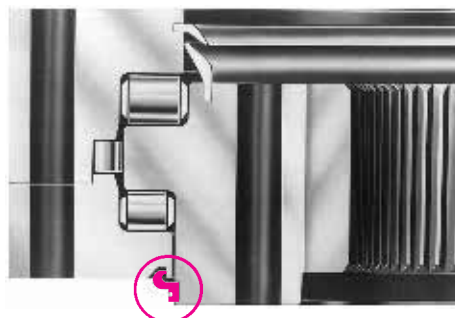

Fig. 25

Raceways

Plastic spacers are inserted between the rolling elements in the raceways. The bearings are supplied already greased. Penetration of aggressive materials into the raceways must be prevented on all accounts. Aggressive materials will alter the lubricating properties which will lead to corrosion in the raceways and damage the plastic spacers.

Special designs

Apart from the standard bearing series shown, we offer bearings tailored to specific operating conditions with regard to dimensions, running accuracies, bearing clearances and materials.

We also manufacture wire-race bearings. This bearing permits the use of non-ferrous metal rings and thus meets any special requirements regarding minimum weight, resistance to corrosion, etc.

Packing

Generally, large-diameter bearings will be wrapped in foil or a similar material for transport. The external bearing surfaces are protected against corrosion by means of Tectyl 502 C (oily) and by filling the raceways with lithium-based grease.

The method of transport will determine the type of packing used (e.g. pallets, crates).

Standard packing will provide adequate protection for storage times of up to one year in enclosed, temperature-controlled areas.

Upon request, other preservation and packing methods can be provided for longer storage times (e.g. long-term packing for 5 years storage).

Wear measurement.



For assessing the condition of a bearing, we recommend that its normal wear rate is determined. The wear present in the raceway system shows itself by a change in the axial motion of the bearing. Depending on the individual conditions, wear can be determined either by measuring the tilting clearance or by reduction measurements.

Used grease samples are taken in parallel, i.e. at the same time. The measurements and the used grease analysis provide further information about the condition of the running system.



Fig. 28: Three-row roller bearing slewing ring – basic test setup for tilting clearance measurement

Axial reduction measurement

In cases where the tilting clearance cannot be measured, we recommend performing the axial reduction measurement. In this case, the centre of gravity of the load combinations should be within the raceway diameter of the bearing. The loading principle is shown in Fig. 30.

The first measurement should be performed when the equipment is put into operation in order to obtain a base value for subsequent repeat measurements.

The measurements should be taken as close to the bearing as possible in order to minimize the effect of elastic deformations in the construction.

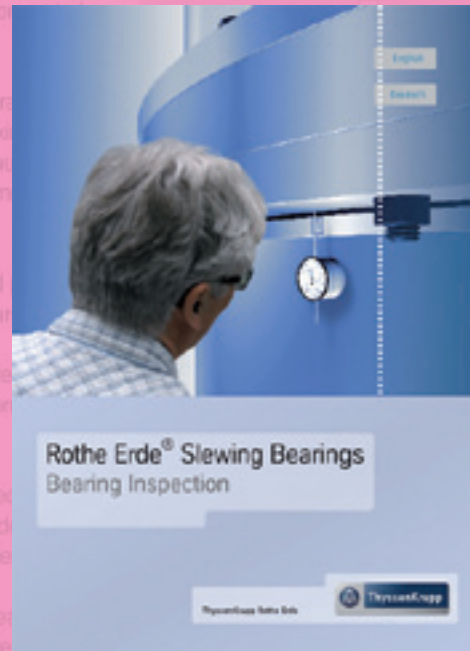

You will find updated information about wear measurement in the brochure

Rothe Erde® Slewing Bearings Bearing Inspection

The link (one click) will automatically direct you to the new brochure.

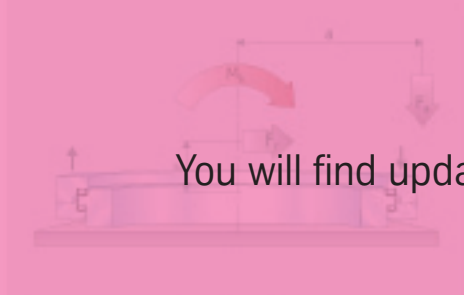

Fig. 26: Loading principle for tilting clearance measurement

Tilting clearance measurement

For equipment on which it is possible, recommend that the wear should be measured by measuring the tilting clearance. The loading principle for a measurement is shown in Fig. 26.

The first measurement should be performed when the equipment is put into operation in order to obtain a base value for subsequent repeat measurements.

Check the bolts first.

The measuring points should be marked on the circumference starting from a defined position (Fig. 27).

The measurements are then taken between the lower connected structure and the bearing bolted to the superstructure (Fig. 28).



Fig. 27

When the superstructure to the marked measuring points have been measured, the base values obtained in tabular form (Fig. 29).

The difference between the values measured and the base values represents the wear that has occurred.

The difference between the values measured and the base values represents the wear that has occurred.

If the wear is found to have increased significantly, the time intervals between measurements should be shortened.

If the acceptable wear values (Tables 9, 10 and 11) are exceeded, please consult Rothe Erde.

Measurement		Base measurement	Test measurement	Test measurement
Measuring point 1 below	boom			
	counterweight			

Fig. 29: Value recording for tilting clearance measurement



Fig. 31

Maximum permissible increase of bearing clearances (equal wear)

Remark: Such increases of the bearing clearance are not permissible for special applications (consultation with Rothe Erde), e.g. 50% of the above values for slewing bearings for roundabouts.

Measuring method	ball diameter mm										
	18	20	22	25	30	35	40	45	50	60	70
	permissible increase in bearing clearance mm										
Axial reduction measurement	1.8			2.2			3.0			3.8	
Tilting clearance measurement	2.5			3.0			4.0			5.0	

Table 9: Double row ball bearing slewing rings (standard series KD 320)

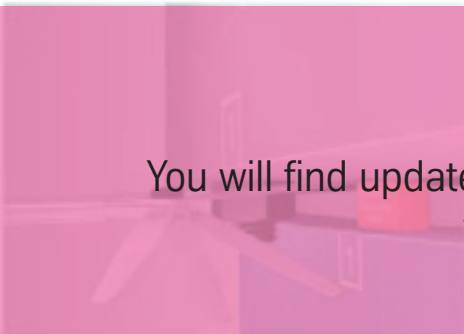
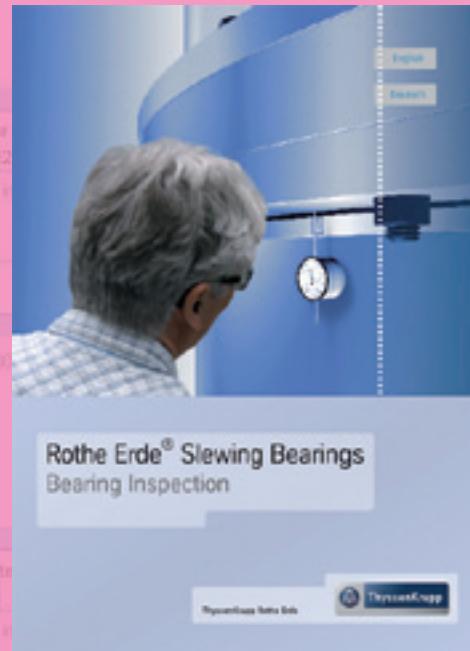

Fig. 32

You will find updated information about **wear measurement** in the brochure

Rothe Erde® Slewing Bearings
Bearing Inspection



If the deviation from the base measurement exceeds the maximum values shown in Tables 9, 10 and 11, please

The link (one click) will automatically direct you to the new brochure.

Measuring method	roller diameter				
	18	20	25	30	35
	permissible increase in bearing clearance mm				
Axial reduction measurement	0.4	0.6	0.8	1.0	1.2
Tilting clearance measurement	0.7	1.0	1.4	1.75	2.1

Table 11: Roller bearing slewing rings

Measurement	Base measurement	Test measurement
Measuring point 1		
Measuring point 2		
Measuring point 3		
Measuring point 4		
Tester		
Signature		
Date		

Fig. 33: Value recording in axial reduction measurement

Transport and storage

Large-diameter antifriction bearings, like any other machine part, require careful handling. Transport and storage only in horizontal position. If transporting at an angle, provide internal reinforcement in the form of a transport cross. Impact loads, particularly in a radial direction, must be avoided.

State of delivery

(unless otherwise agreed):

Running system

lubricated with one of the quality greases specified.

Gear ring

not lubricated; treatment as for external surfaces.

External surfaces

Tectyl 502-C-El or other suitable general-purpose cleaner such as Shell Callina 2306.

Storage

Approx. 6 months in roofed storage
Approx. 12 months in enclosed, temperature-controlled area
Bearings that are not used for a long period require special preservation.

After a long storage period

the bearing could incur high rotation resistance during start up and running through the seal rim. Careful lifting with a blunt article around the entire circumference and repeated rotation of the large antifriction bearing over 360° right and left this reduces the torque to normal values.

Installation

A flat, grease- and oil-free rest is essential for the upper and lower ring to seat solidly. Rothe Erde recommend examination of the bearing surfaces with a levelling instrument or laser machine. Only in exceptional cases for bearings Ø 2,5 m (with corresponding large cross sections) a feeler gauge should be used.

With the feeler gauge measuring method, it is recommended that after the first measurement the bearing is offset by 90° and the measurement repeated.

Table 12

Thread/bolt diameter	Drilling diameter mm	Tightening torque Nm with bolts with a strength class $\mu_0 = \mu_1 = 0.14$			
		for hydr. + electric M_1 torque wrench	for M_1 torque spanner	for hydr. + electric M_1 torque wrench	for M_1 torque spanner
	DIN/ISO 273	8.8	8.8	10.9	10.9
M 12	14	87	78	130	117
M 14	16	140	126	205	184
M 16	17.5	215	193	310	279
M 18	20	300	270	430	387
M 20	22	430	387	620	558
M 24	26	740	666	1060	954
M 27	30	1100	990	1550	1395
M 30	33				1890
UNC 1 1/8-12	33				Grade 8
UNC 1 1/4-14	35				260
UNC 1 3/8-16	37				460
UNC 1 1/2-18	41				730
UNC 1 5/8-20	45				1100
UNC 2-22	51				1560
UNC 2 1/4-24	57				2190
UNC 2 3/4-28	63				Grade 8
UNC 3-30	70				290
UNC 3 1/2-36	79				510
UNC 4-40	89				820
UNC 4 1/2-45	98				1210
UNC 5-50	108				1760
UNC 5 1/2-56	118				2440
UNF 1 1/8-12	35				

You will find updated information about **installation, lubrication, maintenance** in the brochure

Rothe Erde® Slewing Bearings
Installation · Lubrication · Maintenance

The link (one click) will automatically direct you to the new brochure.



Machining of the contact area, as a final manufacturing step is necessary (after welding).

Welding beads, burrs and strong paint residues and other uneven surfaces are to be removed.

Dependent upon the design type and the track diameter "D₁" of the bearing, the maximum out-of-flatness including the slope "P" (mm) of the upper or lower contact surface should not exceed the values shown in Table 8.

Regarding the slope of the machined surfaces, the figures shown in the table refer to a support width of 100 mm.

To avoid larger deviations and the occurrence of peaks in smaller sectors, any deviation in the range of 0° – 90° – 180° may only rise or fall gradually. Prior to installation, the bearing

should be checked for smooth running by rotating the unbolted bearing around its axis, twice.

Should the permissible out-of-flatness, including the slope, be exceeded, we recommend that the contact surfaces for the bearing be machined.

For bearings of standard series KD 320, RD 700 and RD 900 the bearing has to be installed as shown on the drawing.

Remove the protective coating from the bearing's upper and lower support surfaces as well as from the gear. No solvent should be allowed to come in contact with the seals and raceways. Do not clean the gears if these are greased.

Diameter tolerances

Machined diameters with untoleranced drawing dimensions have the following tolerances:

≤ 315 mm	± 1,6 mm
≤ 1000 mm	± 2,5 mm
≤ 2000 mm	± 3,5 mm
≤ 4000 mm	± 5,0 mm
≤ 6300 mm	± 7,0 mm
≤ 10000 mm	± 10,0 mm

All **grease nipples** must be easily accessible. If necessary, grease pipes should be provided to allow relubrication through all grease connections. We recommend automatic lubricating systems.

Hardness gap

The unhardened zone between the beginning and end of the hardened region of the raceway is identified by the hardness gap. The hardness gap is marked on the axial surface. On the ring with a point load the hardness gap "S" must be positioned outside the main load-carrying area.

Gearing

It has to be adjusted at 3 teeth marked in green and is to be at least 0,03 x module. After the final tightening of the bearing, the gear teeth must be rechecked over the entire circumference.

A tip edge radius and a tip relief must be provided on the pinion (see Page 26).

Check that the **bolt holes** in the bearing line up with the holes in the companion structure. Otherwise, the bearing may become stressed. Through holes must conform with DIN/ISO 273, medium series see Table 12.

Standard strength class for **fastening bolts** (without surface treatment): 10.9 to DIN 267.

The quantity and diameter specified must be absolutely adhered to. Bolts must be carefully preloaded crosswise to specified values (Table 12 gives several recommended values).

The surface pressure under the bolt head or nut must not exceed the permissible maximum value.

When the permissible pressure is exceeded, washers with the respective size and strength have to be provided. The minimum bolt length

must be assured. If a hydraulic tensioning device is applied, corresponding washers have to be used (see Page 20).

The determination of the **tightening torque** depends not only on the strength class of the bolt and the tightening process, but depends on the friction in the thread and on the area surface bolt head and nut. The tightening torques given in the table are recommended values based on lightly oiled threads and contact surfaces. Dry threads will require higher torques whilst heavily oiled threads will require lower tightening torques. The values may, therefore, vary considerably. This applies in particular to M 30 or 1 1/2" threads and larger.

For bolts of this size and larger we recommend the use of hydraulic tensioning devices. Welding of the bearing or welding in the raceway may cause distortions. Excessive force generated may cause distortions. Excessive force generated may cause distortions.

Lubrication and maintenance
The first relubrication of the raceway must be carried out immediately after the installation of the bearing. Subsequent lubrication, the lubricants used are solely KP 2 K greases, i.e. NLGI Grade 2. Greases of other grades may be used if they can be mixed together.

The lubricants are listed in random order and not according to quality.

The grease filling is there to reduce friction, seal the bearing and provide protection against corrosion. Therefore, the bearing must always be greased liberally so that a collar of fresh grease forms around the whole circumference of the bearing gaps and seals. The bearing should be rotated during relubrication.

Use a spatula to remove excessive grease which might egress (grease collar is to remain unchanged) and dispose it as prescribed. Carefully remove lubricants dripping down in areas in which persons may stay so as to avoid the risk that they might skid.

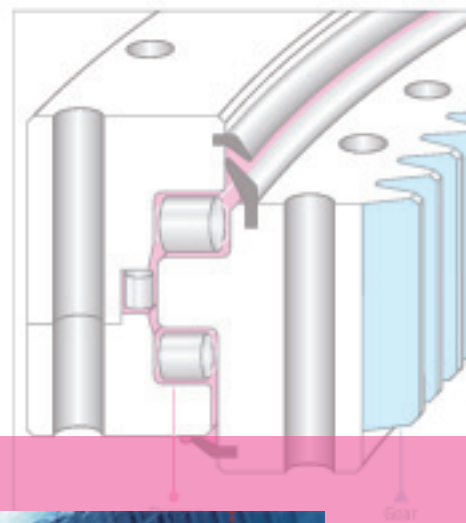

You will find updated information about **installation, lubrication, maintenance** in the brochure

Rothe Erde® Slewing Bearings
Installation · Lubrication · Maintenance

The link (one click) will automatically direct you to the new brochure.

could be manufacturer. The improved for our ggs and tested is stipulated by

only for the sivity of a use (spacers elastic or other

the user on from the lubricant manufacturer or supplier that the grease he has chosen is suitable for the intended application and that its properties are at least equivalent to those of the greases listed in our table. It must be guaranteed that the lubricant will not undergo any change in its composition and this also applies to future deliveries.

When automatic lubricating devices are used, the lubricant manufacturer must confirm pumpability.

With low temperatures special lubricants are necessary.

It is the responsibility of the maintenance personnel to ensure individual consumption rates by accurate checking of the lubricated condition of both the raceway and gear.

Lubrication period for the raceway system

Select according to operating conditions. With special required parameters, consultation with Rothe Erde should be held. Generally about every 100 operating hours. Roller bearings about every 50 operating hours. Shorter lubrication periods: In the tropics, by high amounts of moisture, after dust or dirt effects, strong temperature changes, as well as continuous rotation.

For bogie bearings in rail vehicles and tram vehicles as well as bearing for wind energy, special regulations apply.

If there are standstill times between bearing installation and equipment start-up, respective maintenance procedures will be required, e.g. relubrication under rotation no later than 3 after months and every 6 months.

Before and after installation of the bearing on the equipment, relubrication is absolutely necessary. This is especially important after a winter shutdown. When cleaning the equipment, care must be taken to prevent cleaning agents from damaging the seals or penetrating into the raceways. The seals must be checked every 6 months.

Lubrication intervals for the gear

We recommend automatic lubrication. In the case of hand lubrication, pinion and gear are to be greased sufficiently with grease as recommended in Table 13. A weekly gear lubrication is recommended. The gear should always have sufficient grease.

Examination of bolts

The bolt connection has to keep a sufficient preload during the whole bearing life. For compensation of settlement phenomena a refastening on regular base may be necessary.

Checking of the raceway system

In their delivered condition large-diameter anti-friction bearings have clearances which guarantee good operating conditions and functional safety. When the bearing is put into operation, we recommend to perform a base measurement. After a prolonged operating time, bearing clearances will increase. It is, therefore, necessary to check the axial movement or settling at regular intervals (see Page 36 or contact Rothe Erde for further information).

Disposal at end of useful life

Rothe Erde bearings are made of high-quality steel. The bearings are not to be disposed of in accordance with the regulations for hazardous waste. The bearings are to be recycled as scrap metal.

Table 13

ARAL	●	Aralub HLP 2	243 K to 393 K (-30°C to +120°C)
	▲	Aralub MKA-Z 1	263 K to 453 K (-10°C to +180°C)
Castrol	●	Sphereol EPL 2	253 K to 413 K (-20°C to +140°C)
	▲	Mobilub-Alloy 970/2500-1	253 K to 363 K (-20°C to +90°C)
TOTAL	●	Multis EP 2	248 K to 393 K (-25°C to +120°C)
	▲	Ceran AD PLUS	248 K to 423 K (-25°C to +150°C)



The image shows the cover of a technical brochure. The top half features a blue-tinted photograph of a slewing bearing with a navigation menu on the right side containing buttons for 'Home', 'About', 'Products', 'Services', 'Contact', and 'FAQ'. The bottom half is a solid blue area with the title 'Rothe Erde® Slewing Bearings' and subtitle 'Installation · Lubrication · Maintenance'. At the bottom, there are logos for 'The bearings Rothe Erde' and 'DryStar®app'.

You will find updated information about installation, lubrication, maintenance in the brochure

Rothe Erde® Slewing Bearings
Installation · Lubrication · Maintenance

The link (one click) will automatically direct you to the new brochure.

Drawing number composition.



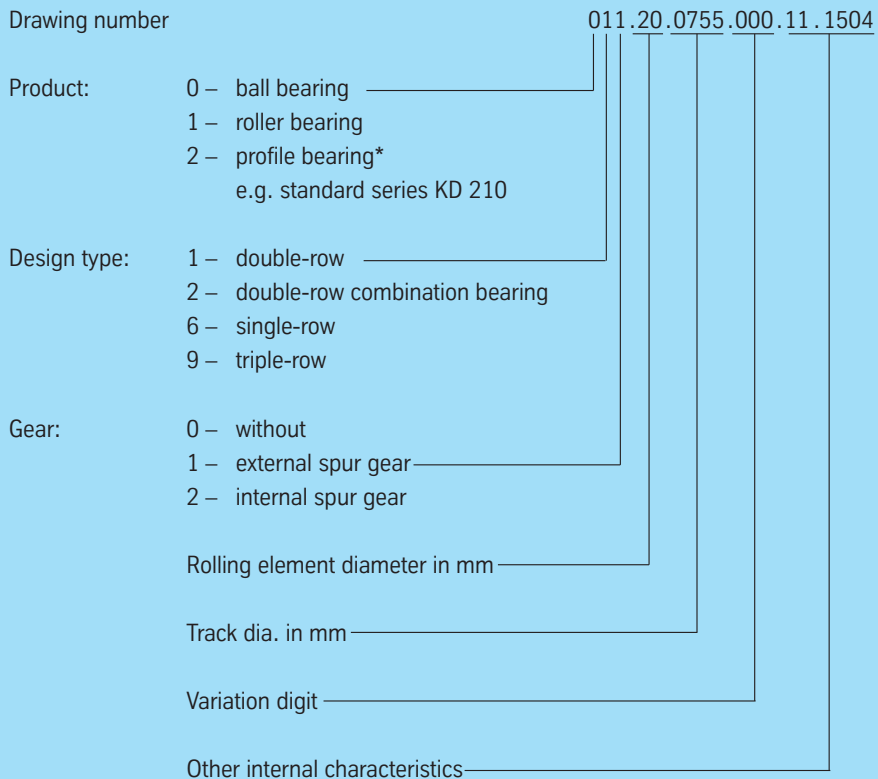

Rothe Erde
Slewing Bearings

The drawing number contains a description of several important design features. The drawing number for the first bearing of the KD 320 standard series is given as an example.

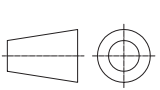

*) The subsequent digits do not apply to product "2".

Example of a title block with tolerance details for machined diameters:

Untolerierte Durchmesser-Maße (spanend bearbeitet) Dia. dim. without tolerance (machined)				Maßstab Scale	1:1	Gewicht Weight	500	kg/kgs
≤315	≤1000	≤2000	≤4000	≤6300	≤10000	Ident-Nr. Ident-No. 12345678		
±1.6	±2.5	±3.5	±5.0	±7.0	±10.0	Benennung / Title Kugeldrehverbindung Ball Bearing Slewing Ring		
 Schutzvermerk ISO 16016 beachten Copyright reserved	Datum/Date		Name		Werkstoff/Material: Zeichnungs-Nr. / Drawing No. 060.50.1500.000.41.1504			
	Bearb. Drawn by.							
 Rothe Erde		Gepr. Check by.				Entwurf/Arisen from: 060.50.1500/00.125421.4		

See also page 39.

Standard series KD 210

Single-row ball bearing slewing rings
Profile bearings

Pages 43 – 55

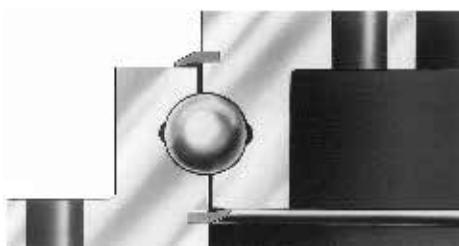

Standard series KD 210.



The KD 210 standard series is a light-weight series from the Rothe Erde bearing range.

For reasons of economy the bearing cross sections in this standard series are relatively small. It is, therefore, necessary to mount these bearings on a distortion-proof companion structure.

The contact surfaces for the bearings must be flat to avoid bearing distortion during bolting as this might cause tight spots in the raceways which would lead to peak loads at these points. For this reason, machining of all contact surfaces is required. For permissible deviations, see Page 34.

In cases where finish-machining is not possible, any remaining out-of-flatness may be compensated for by means of a cast resin grouting.

Accuracies

The bearings are available in two classes of accuracy:

Standard bearings Precision bearings

The bearing clearances for the individual bearing types are listed in the respective dimensional tables.

Installation, Lubrication, Maintenance

see Pages 38 – 40.

The hardness gap (beginning and end of the raceway hardening zone, marked by a punched-in "S") or the filler plug on the profile ring should be located in the neutral low-load zone of the point-loaded ring. This zone will also accommodate the bolt hole missing in the filler plug area in bearing Type 21 which is provided with double the number of bolt holes.

If a central lubrication system is provided, the existing lubricating nipples may be removed and replaced by the following adaptors.

Available adaptors

Thread dia. A	Thread dia. B
grease nipple thread M 8 x 1	M 10 x 1 M 12 x 1.5 R 1/8" R 1/4" 1/8"-27 NPTF (con.) 1/4"-28 NF

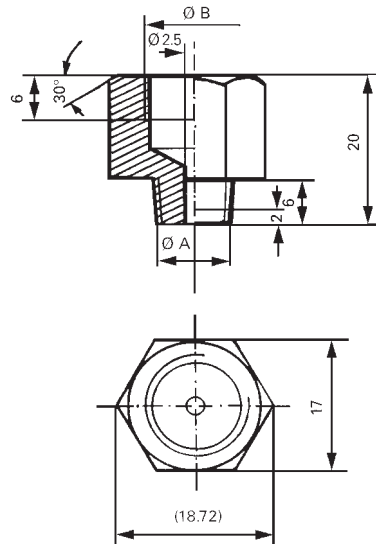

Materials

Ungeared rings

Types 13 and 21, C 45 rolled profile steel according to DIN 17 200
Type 110, 46 Cr 4 N according to DIN 17 200

Geared rings

Type 21, C 45 N according to DIN 17 200
Type 110, 46 Cr 4 N according to DIN 17 200

Permissible bending stresses in the tooth root:

130 N/mm² standard
260 N/mm² short-time maximum

Rolling elements

bearing steel

Ball tracks

Type 13, unhardened or induction-hardened
Type 21, induction-hardened
Type 110, induction-hardened

Diagrams

The **limiting load curves for raceways** apply only to a supported axial load. The limiting load diagrams for types 13 and 21 are to be used with the maximum loads including all additional loads, test loads and impact factors (static and dynamic).

For type 110, the maximum load determined is to be multiplied with the "load factors" according to Table 1 on Page 11.

The reference load must be lower than the limiting load curve.

The **limiting load curves for bolts** apply to the standard or double quantity of 10.9 bolts in profile rings. 10.9 bolts are adequately dimensioned for geared rings.

Limiting load curves for bolts which are not shown here exceed the limiting load curves for the raceways.

The following conditions apply to the bolting of the bearing:

- Clamping length 5 x d for full rings
- Clamping length 3 x d for profiled rings
- 5 interfaces
- Preload at least 70 % of the yield limit.

In the case of a suspended axial load and additional radial forces occurring over and above the driving force, the raceway and bolt calculations will have to be checked by us.

Standard series KD 210



Standard series type 13, Standard bearings Bearing with limited clearance

Standard bearings ungeared

Drawing No.	Ball track dia. D_L [mm]	Weight [kg]	Outer diameter (O.D.) D_a [mm]	Inner diameter (I.D.) D_i [mm]	Overall height H [mm]	External bolt circle dia. L_a [mm]	Internal bolt circle dia. L_i [mm]	Number of bolt holes n_a	Bolt hole diameter B [mm]	Number of bolt holes n_i	Bolt hole diameter B [mm]	Number of grease nipples n_1	Diameter O [mm]	Diameter U [mm]	Bearing clearances ①	
															axial [mm]	radial [mm]
250.14.0300.013 Typ 13/400	323	9,6	401	233	40	380	260	8	14	8	14	4	348	298	$\leq 0,5$	$\leq 0,5$
250.14.0400.013 Typ 13/500	421	13,1	501	333	40	480	360	8	14	8	14	4	446	396	$\leq 0,5$	$\leq 0,5$
250.15.0300.013 Typ 13/400	323	9,6	401	233	40	380	260	8	14	8	14	4	348	298	$\leq 0,5$	$\leq 0,5$
250.15.0400.013 Typ 13/500	421	13,1	501	333	40	480	360	8	14	8	14	4	446	396	$\leq 0,5$	$\leq 0,5$

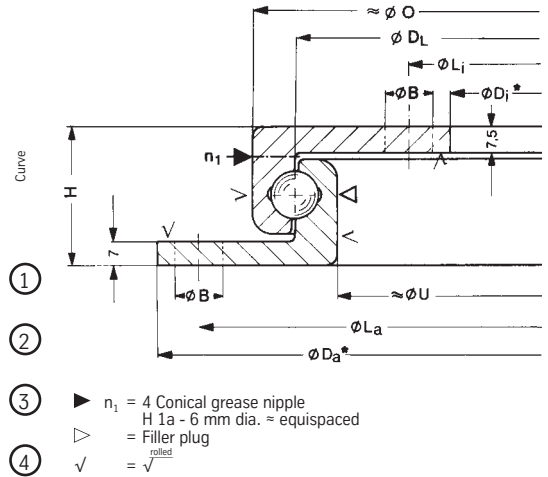

$n_1 = 4$ Conical grease nipple
 $H 1a = 6$ mm dia. \approx equispaced
 ∇ = Filler plug
 \checkmark = $\sqrt{\text{pilot}}$

* If pilots are required on standard bearings, it is essential that this is indicated at the time of ordering. Pilots can only be provided at nominal diameters marked with an *.

Pilot tolerances:	Outside	Inside
Type 13/400 13/500	-0.5 mm	+0.5 mm

Bearing with limited clearance ungeared

250.15.0375.013 Typ 13/400	323	9,6	400 -0,09	234 +0,07	40	380	260	8	14	8	14	4	348	298	≤ 0 to 0,02	③
250.15.0475.013 Typ 13/500	421	13,1	500 -0,10	334 +0,09	40	480	360	8	14	8	14	4	446	396	≤ 0 to 0,02	④

① Axial clearance = tilting clearance

Static limiting load curves

—— Raceway - - - Bolts

For loads exceeding the limiting bolt load curve ④, the number of fastening bolts must be doubled.

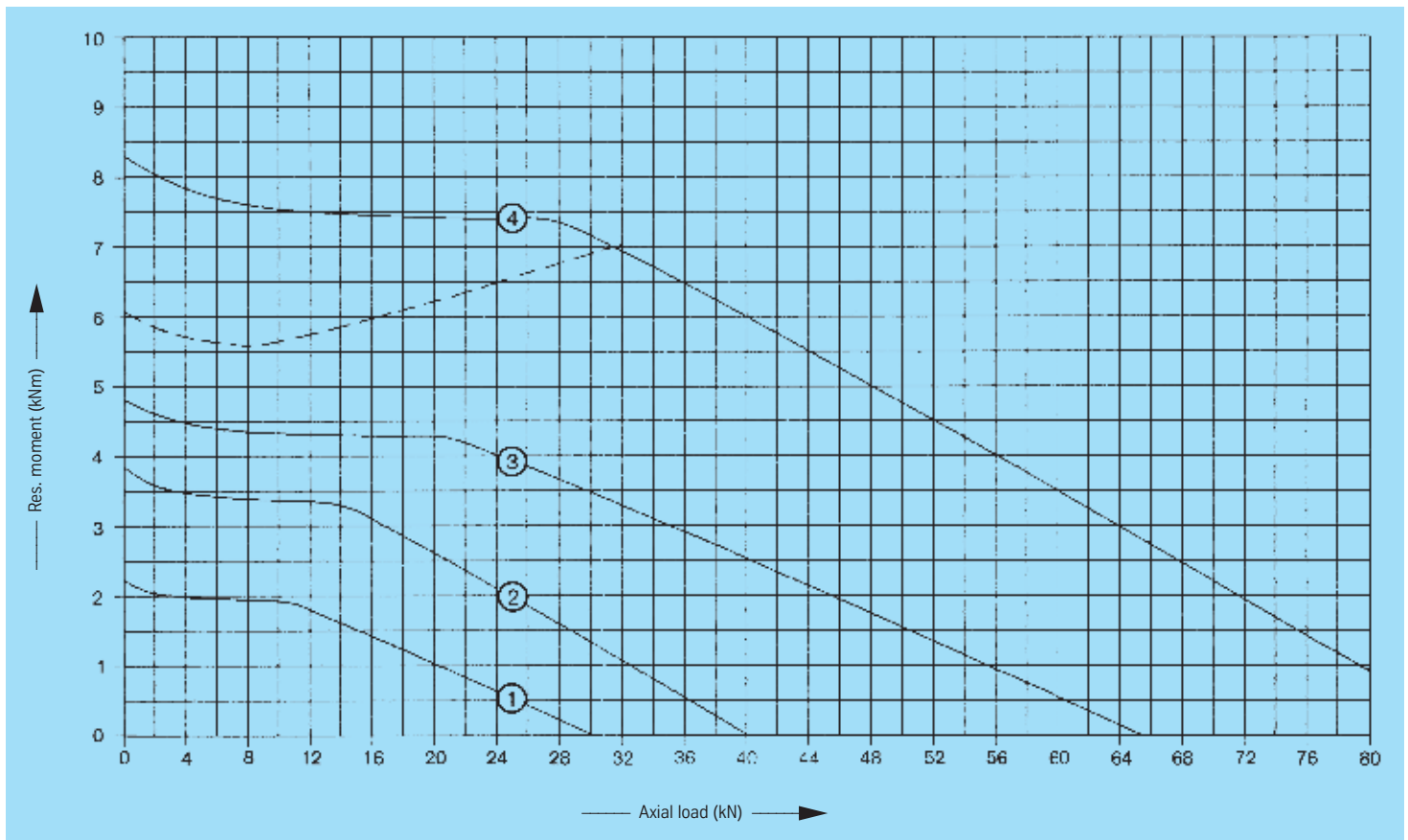

Standard series KD 210



Rothe Erde
Slewing Bearings

Standard bearing type 21, standard number of bolt holes, profile ring

Double number of bolt holes, see curves ⑫ ... ⑮

Bearing ungeared

Drawing No.	Ball track diameter D_L [mm]	Weight [kg]	Outer diameter (O.D.) D_a [mm]	Inner diameter (I.D.) D_i [mm]	Overall height H [mm]	External bolt circle diameter L_a [mm]	Internal bolt circle diameter L_i [mm]	Number of bolt holes n_a	External hole diameter B/M [mm]	Number of bolt holes n_i	Internal hole diameter B/M [mm]	Thread depth t [mm]	Number of grease nipples n_1	Diameter O [mm]	Diameter U [mm]	Diameter A [mm]	Diameter C [mm]	Distance at bottom outer ring/inner ring H_u [mm]	Distance at top outer ring/inner ring H_o [mm]	Gear P.C.D. d [mm]	Module m [mm]	Number of teeth z	Tooth width b [mm]	Addendum reduction $k \cdot m$ [mm]	Permissible tangential forces normal [kN]	Permissible tangential forces maximum [kN]	Bearing clearances ①		Curves		
																											axial [mm]	radial [mm]			
230.20.0400.013 Typ 21/520.0	414	23,4	518	304	56	490	332	8	18	12	18	-	4	412,5	415,5	453	375	10,5	10,5	-	-	-	-	-	-	-	-	-	≤ 0,5	≤ 0,5	⑤
230.20.0500.013 Typ 21/650.0	544	31,0	648	434	56	620	462	10	18	14	18	-	4	542,5	545,5	583	505	10,5	10,5	-	-	-	-	-	-	-	-	-	≤ 0,5	≤ 0,5	⑥
230.20.0600.013 Typ 21/750.0	644	36,4	748	534	56	720	562	12	18	18	18	-	4	642,5	645,5	683	605	10,5	10,5	-	-	-	-	-	-	-	-	-	≤ 0,5	≤ 0,5	⑦
230.20.0700.013 Typ 21/850.0	744	42,8	848	634	56	820	662	12	18	16	18	-	4	742,5	745,5	783	705	10,5	10,5	-	-	-	-	-	-	-	-	-	≤ 0,5	≤ 0,5	⑧
230.20.0800.013 Typ 21/950.0	844	47,8	948	734	56	920	762	14	18	18	18	-	4	842,5	845,5	883	805	10,5	10,5	-	-	-	-	-	-	-	-	-	≤ 0,5	≤ 0,5	⑨
230.20.0900.013 Typ 21/1050.0	944	53,1	1048	834	56	1020	862	16	18	20	18	-	4	942,5	945,5	983	905	10,5	10,5	-	-	-	-	-	-	-	-	-	≤ 0,5	≤ 0,5	⑩
230.20.1000.013 Typ 21/1200.0	1094	61,9	1198	984	56	1170	1012	16	18	20	18	-	4	1092,5	1095,5	1133	1055	10,5	10,5	-	-	-	-	-	-	-	-	-	≤ 0,5	≤ 0,5	⑪

① Axial clearance = tilting clearance

Bearings with external gear

231.20.0400.013 Typ 21/520.1	414	29,3	504	304	56	455	332	10	M 12	12	18	20	4	412,5	415,5	-	375	10,5	-	495	5	99	45,5	-0,5	11,75	23,50	≤ 0,5	≤ 0,5	⑤
231.20.0500.013 Typ 21/650.1	544	39,5	640,8	434	56	585	462	14	M 12	14	18	20	4	542,5	545,5	-	505	10,5	-	630	6	105	45,5	-0,6	14,20	28,40	≤ 0,5	≤ 0,5	⑥
231.20.0600.013 Typ 21/750.1	644	47,6	742,8	534	56	685	562	16	M 12	16	18	20	4	642,5	645,5	-	605	10,5	-	732	6	122	45,5	-0,6	14,20	28,40	≤ 0,5	≤ 0,5	⑦
231.20.0700.013 Typ 21/850.1	744	53,5	838,8	634	56	785	662	18	M 12	16	18	20	4	742,5	745,5	-	705	10,5	-	828	6	138	45,5	-0,6	14,20	28,40	≤ 0,5	≤ 0,5	⑧
231.20.0800.013 Typ 21/950.1	844	65,1	950,4	734	56	885	762	18	M 12	18	18	20	4	842,5	845,5	-	805	10,5	-	936	8	117	45,5	-0,8	18,93	37,86	≤ 0,5	≤ 0,5	⑨
231.20.0900.013 Typ 21/1050.1	944	69,6	1046,4	834	56	985	862	20	M 12	20	18	20	4	942,5	945,5	-	905	10,5	-	1032	8	129	45,5	-0,8	18,93	37,86	≤ 0,5	≤ 0,5	⑩
231.20.1000.013 Typ 21/1200.1	1094	83,0	1198,4	984	56	1135	1012	22	M 12	20	18	20	4	1092,5	1095,5	-	1055	10,5	-	1184	8	148	45,5	-0,8	18,93	37,86	≤ 0,5	≤ 0,5	⑪

▲ New α D_a off 1991 addendum reduction 0,1 · m

① Axial clearance = tilting clearance

Bearings with internal gear

232.20.0400.013 Typ 21/520.2	414	27,1	518	326,5	56	490	375	8	18	12	M 12	20	4	412,5	415,5	453	-	10,5	-	335	5	67	45,5	-0,75	13,54	27,08	≤ 0,5	≤ 0,5	⑤
232.20.0500.013 Typ 21/650.2	544	36,9	648	445,2	56	620	505	10	18	16	M 12	20	4	542,5	545,5	583	-	10,5	-	456	6	76	45,5	-0,6	16,00	32,00	≤ 0,5	≤ 0,5	⑥
232.20.0600.013 Typ 21/750.2	644	43,7	748	547,2	56	720	605	12	18	18	M 12	20	4	642,5	645,5	683	-	10,5	-	558	6	93	45,5	-0,6	15,62	31,24	≤ 0,5	≤ 0,5	⑦
232.20.0700.013 Typ 21/850.2	744	51,1	848	649,2	56	820	705	12	18	20	M 12	20	4	742,5	745,5	783	-	10,5	-	660	6	110	45,5	-0,6	15,32	30,64	≤ 0,5	≤ 0,5	⑧
232.20.0800.013 Typ 21/950.2	844	61,6	948	737,6	56	920	805	14	18	20	M 12	20	4	842,5	845,5	883	-	10,5	-	752	8	94	45,5	-0,8	20,80	41,60	≤ 0,5	≤ 0,5	⑨
232.20.0900.013 Typ 21/1050.2	944	65,8	1048	841,6	56	1020	905	16	18	22	M 12	20	4	942,5	945,5	983	-	10,5	-	856	8	107	45,5	-0,8	20,49	40,98	≤ 0,5	≤ 0,5	⑩
232.20.1000.013 Typ 21/1200.2	1094	80,7	1198	985,6	56	1170	1055	16	18	24	M 12	20	4	1092,5	1095,5	1133	-	10,5	-	1000	8	125	45,5	-0,8	20,16	40,32	≤ 0,5	≤ 0,5	⑪

① Axial clearance = tilting clearance

Standard series KD 210



Standard bearing type 21, standard number of bolt holes, profile ring

Double number of bolt holes, see curves 12 ... 18

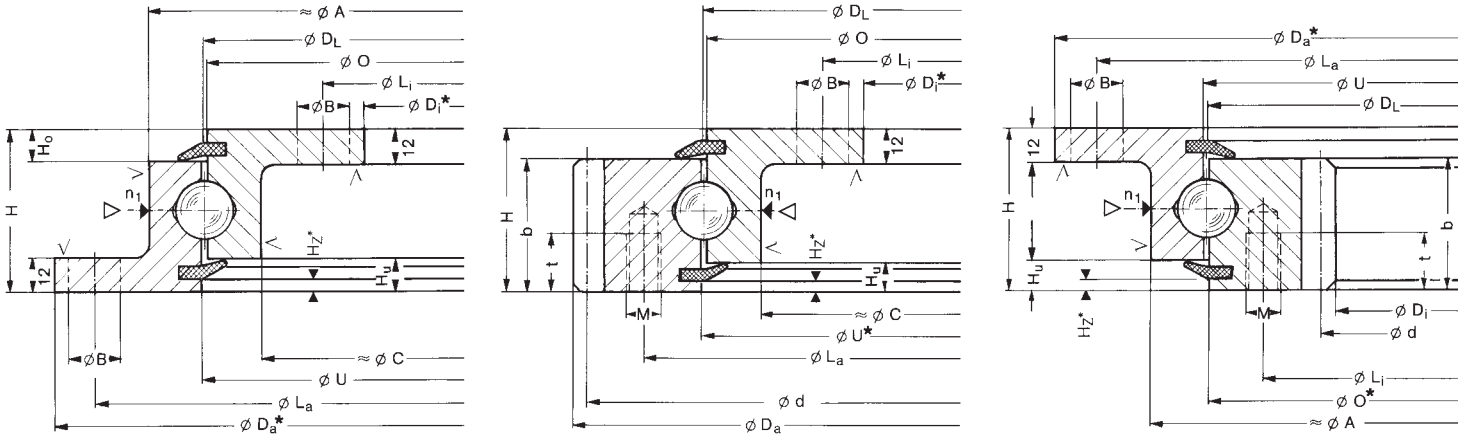

- ▶ $n_1 = 4$ Conical grease nipple
AM 8 x 1 DIN 71412
= equispaced
With ungeared bearings
the grease nipples may be
located on the inner ring,
if requested.
- ▷ = Filler plug
- √ = $\sqrt{\text{rolled}}$

*If pilots are required on standard bearings, it is essential that this is indicated at the time of ordering.
Pilots can only be provided at nominal diameters marked with an *.

Pilot tolerances:	Outside	Inside
Type 21/ 520 21/ 650	-0.5 mm	+0.5 mm
Type 21/ 750 21/ 950	-0.6 mm	+0.6 mm
Type 21/1050 21/1200	-0.7 mm	+0.7 mm

Pilot height $H_2^* = 4.5$ mm
Pilot height of companion structure = $(H_2 - 1)$ mm

Static limiting load curves

—— Raceway - - - Bolts

For loads exceeding the limiting load curves for the bolts, the number of fastening bolts must be doubled.

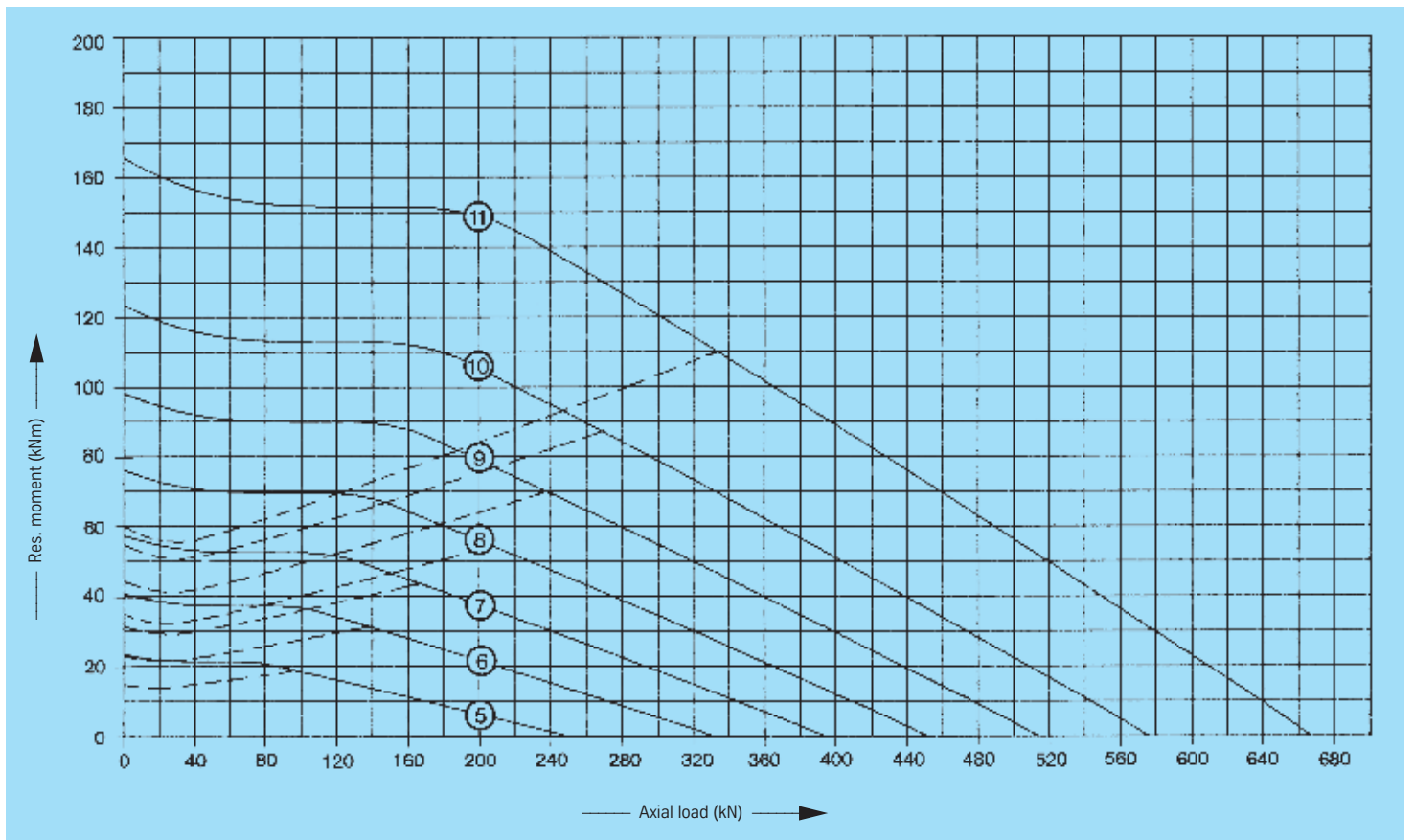

Standard series KD 210



Rothe Erde
Slewing Bearings

Standard bearing type 21, double number of bolt holes, profile ring

One bolt hole missing in the region of the filler plug

Bearing ungeared

Drawing No.	Ball track diameter D_L [mm]	Weight [kg]	Outer diameter (O.D.) D_a [mm]	Inner diameter (I.D.) D_i [mm]	Overall height H [mm]	External bolt circle diameter L_a [mm]	Internal bolt circle diameter L_i [mm]	Number of bolt holes n_a	External hole diameter B/M [mm]	Number of bolt holes n_i	Internal hole diameter B/M [mm]	Thread depth t [mm]	Number of grease nipples n_1	Diameter O [mm]	Diameter U [mm]	Diameter A [mm]	Diameter C [mm]	Distance at bottom outer ring/inner ring H_u [mm]	Distance at top outer ring/inner ring H_o [mm]	Gear P.C.D. d [mm]	Module m [mm]	Number of teeth z	Tooth width b [mm]	Addendum reduction $k \cdot m$ [mm]	Permissible tangential forces normal [kN]	Permissible tangential forces maximum [kN]	Bearing clearances ①		Curves		
																											axial [mm]	radial [mm]			
230.20.0400.503 Typ 21/520.0	414	23,0	518	304	56	490	332	16	18	24	18	-	4	412,5	415,5	453	375	10,5	10,5	-	-	-	-	-	-	-	-	-	≤ 0,5	≤ 0,5	⑫
230.20.0500.503 Typ 21/650.0	544	30,4	648	434	56	620	462	20	18	28	18	-	4	542,5	545,5	583	505	10,5	10,5	-	-	-	-	-	-	-	-	-	≤ 0,5	≤ 0,5	⑬
230.20.0600.503 Typ 21/750.0	644	35,8	748	534	56	720	562	24	18	32	18	-	4	642,5	645,5	683	605	10,5	10,5	-	-	-	-	-	-	-	-	-	≤ 0,5	≤ 0,5	⑭
230.20.0700.503 Typ 21/850.0	744	42,2	848	634	56	820	662	24	18	32	18	-	4	742,5	745,5	783	705	10,5	10,5	-	-	-	-	-	-	-	-	-	≤ 0,5	≤ 0,5	⑮
230.20.0800.503 Typ 21/950.0	844	47,1	948	734	56	920	762	28	18	36	18	-	4	842,5	845,5	883	805	10,5	10,5	-	-	-	-	-	-	-	-	-	≤ 0,5	≤ 0,5	⑯
230.20.0900.503 Typ 21/1050.0	944	52,3	1048	834	56	1020	862	32	18	40	18	-	4	942,5	945,5	983	905	10,5	10,5	-	-	-	-	-	-	-	-	-	≤ 0,5	≤ 0,5	⑰
230.20.1000.503 Typ 21/1200.0	1094	61,1	1198	984	56	1170	1012	32	18	40	18	-	4	1092,5	1095,5	1133	1055	10,5	10,5	-	-	-	-	-	-	-	-	-	≤ 0,5	≤ 0,5	⑱

① Axial clearance = tilting clearance

Bearings with external gear

231.20.0400.503 Typ 21/520.1	414	29,0	504	304	56	455	332	10	M 12	24	18	20	4	412,5	415,5	-	375	10,5	-	495	5	99	45,5	-0,5	11,75	23,50	≤ 0,5	≤ 0,5	⑫
231.20.0500.503 Typ 21/650.1	544	39,2	640,8	434	56	585	462	14	M 12	28	18	20	4	542,5	545,5	-	505	10,5	-	630	6	105	45,5	-0,5	14,20	28,40	≤ 0,5	≤ 0,5	⑬
231.20.0600.503 Typ 21/750.1	644	47,2	742,8	534	56	685	562	16	M 12	32	18	20	4	642,5	645,5	-	605	10,5	-	732	6	122	45,5	-0,6	14,20	28,40	≤ 0,5	≤ 0,5	⑭
231.20.0700.503 Typ 21/850.1	744	53,1	838,8	634	56	785	662	18	M 12	32	18	20	4	742,5	745,5	-	705	10,5	-	828	6	138	45,5	-0,6	14,20	28,40	≤ 0,5	≤ 0,5	⑮
231.20.0800.503 Typ 21/950.1	844	64,7	950,4	734	56	885	762	18	M 12	36	18	20	4	842,5	845,5	-	805	10,5	-	936	8	117	45,5	-0,8	18,93	37,86	≤ 0,5	≤ 0,5	⑯
231.20.0900.503 Typ 21/1050.1	944	69,1	1046,4	834	56	985	862	20	M 12	40	18	20	4	942,5	945,5	-	905	10,5	-	1032	8	129	45,5	-0,8	18,93	37,86	≤ 0,5	≤ 0,5	⑰
231.20.1000.503 Typ 21/1200.1	1094	82,5	1198,4	984	56	1135	1012	22	M 12	40	18	20	4	1092,5	1095,5	-	1055	10,5	-	1184	8	148	45,5	-0,8	18,93	37,86	≤ 0,5	≤ 0,5	⑱

▲ New α D_a off 1991 addendum reduction 0,1 · m

① Axial clearance = tilting clearance

Bearings with internal gear

232.20.0400.503 Typ 21/520.2	414	26,9	518	326,5	56	490	375	16	18	12	M 12	20	4	412,5	415,5	453	-	10,5	-	335	5	67	45,5	-0,75	13,54	27,08	≤ 0,5	≤ 0,5	⑫
232.20.0500.503 Typ 21/650.2	544	36,7	648	445,2	56	620	505	20	18	16	M 12	20	4	542,5	545,5	583	-	10,5	-	456	6	76	45,5	-0,6	16,00	32,00	≤ 0,5	≤ 0,5	⑬
232.20.0600.503 Typ 21/750.2	644	43,4	748	547,2	56	720	605	24	18	18	M 12	20	4	642,5	645,5	683	-	10,5	-	558	6	93	45,5	-0,6	15,62	31,24	≤ 0,5	≤ 0,5	⑭
232.20.0700.503 Typ 21/850.2	744	50,8	848	649,2	56	820	705	24	18	20	M 12	20	4	742,5	745,5	783	-	10,5	-	660	6	110	45,5	-0,6	15,32	30,64	≤ 0,5	≤ 0,5	⑮
232.20.0800.503 Typ 21/950.2	844	61,3	948	737,6	56	920	805	28	18	20	M 12	20	4	842,5	845,5	883	-	10,5	-	752	8	94	45,5	-0,8	20,80	41,60	≤ 0,5	≤ 0,5	⑯
232.20.0900.503 Typ 21/1050.2	944	65,4	1048	841,6	56	1020	905	32	18	22	M 12	20	4	942,5	945,5	983	-	10,5	-	856	8	107	45,5	-0,8	20,49	40,98	≤ 0,5	≤ 0,5	⑰
232.20.1000.503 Typ 21/1200.2	1094	80,3	1198	985,6	56	1170	1055	32	18	24	M 12	20	4	1092,5	1095,5	1133	-	10,5	-	1000	8	125	45,5	-0,8	20,16	40,32	≤ 0,5	≤ 0,5	⑱

① Axial clearance = tilting clearance

Standard series KD 210



Standard bearing type 21, double number of bolt holes, profile ring

One bolt hole missing in the region of the filler plug

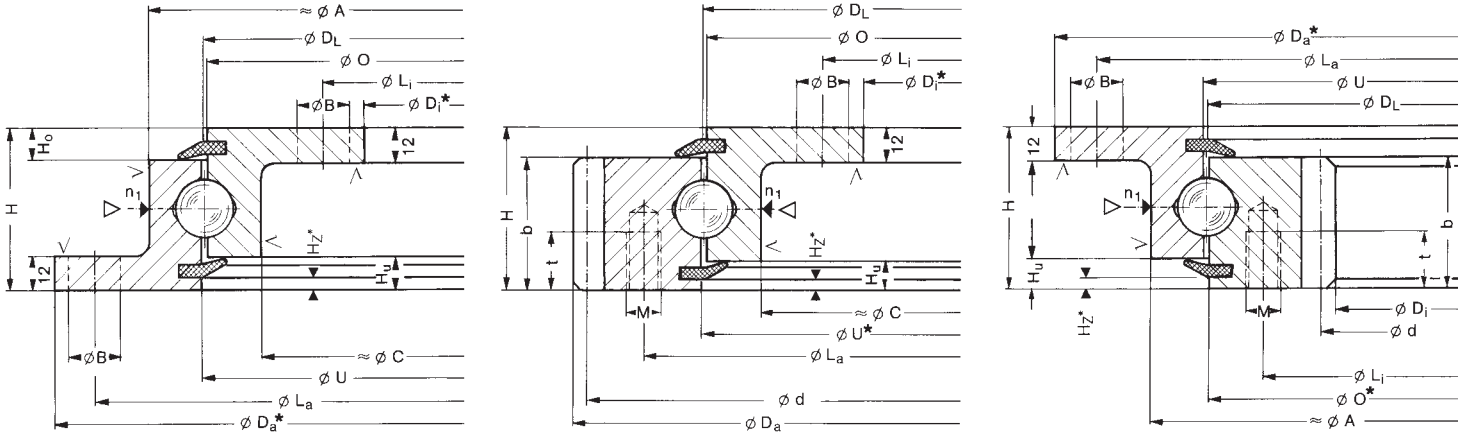

- ▶ $n_1 = 4$ Conical grease nipple
AM 8 x 1 DIN 71412
= equispaced
With ungeared bearings
the grease nipples may be
located on the inner ring,
if requested.
- ▷ = Filler plug
- ✓ = $\sqrt{\text{rolled}}$

*If pilots are required on standard bearings, it is essential that this is indicated at the time of ordering.
Pilots can only be provided at nominal diameters marked with an *.

Pilot tolerances:	Outside	Inside
Type 21/ 520 21/ 650	-0.5 mm	+0.5 mm
Type 21/ 750 21/ 950	-0.6 mm	+0.6 mm
Type 21/1050 21/1200	-0.7 mm	+0.7 mm

Pilot height $H_2^* = 4.5$ mm
Pilot height of companion structure = $(H_2 - 1)$ mm

Static limiting load curves

———— Raceway - - - - Bolts

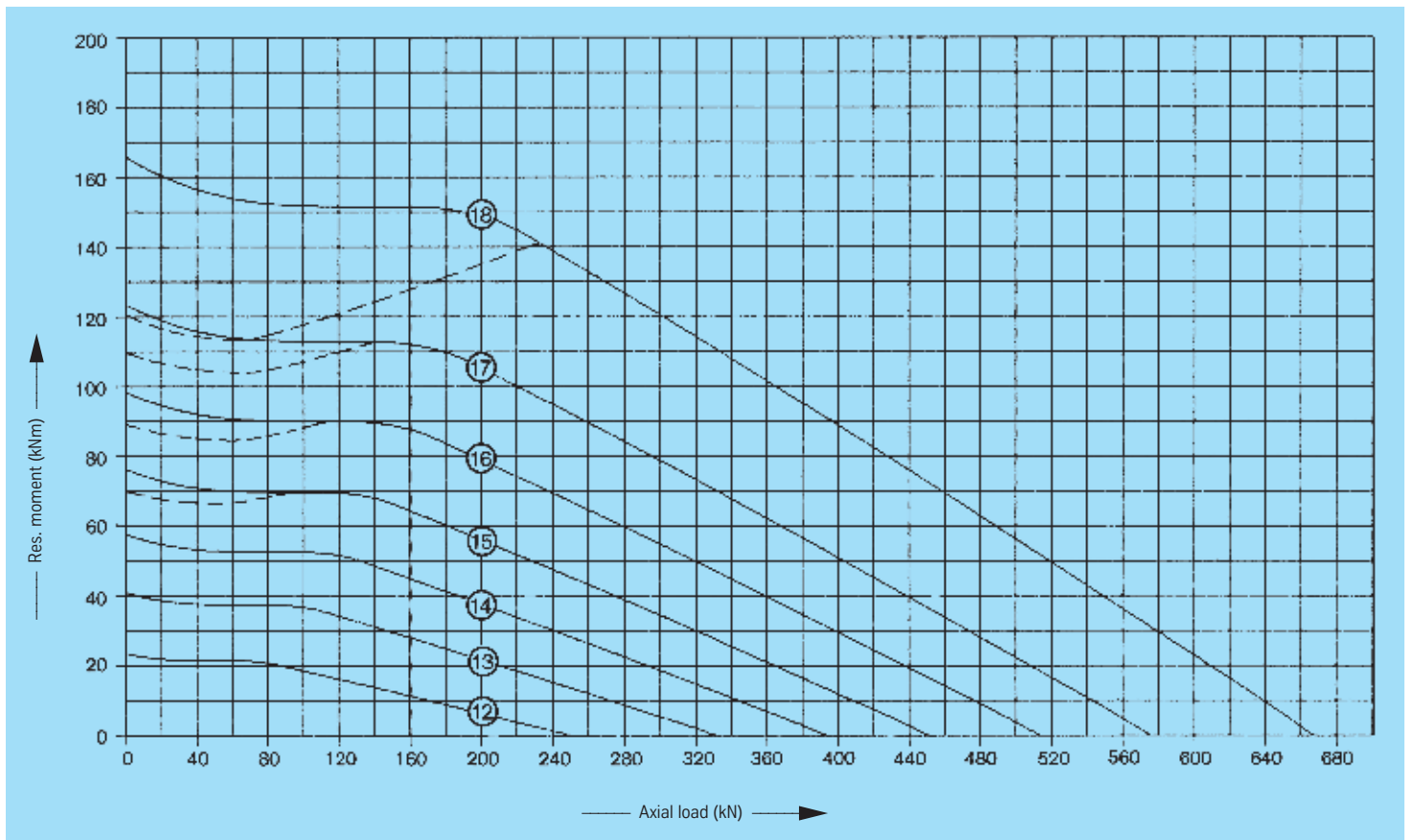

Standard series KD 210

Standard bearing type 21, Bearing with limited clearance



Rothe Erde
Slewing Bearings

Bearing ungeared

Drawing No.	Ball track diameter D_L [mm]	Weight [kg]	Outer diameter (O.D.) D_a [mm]	Inner diameter (I.D.) D_i [mm]	Overall height H [mm]	External bolt circle diameter L_a [mm]	Internal bolt circle diameter L_i [mm]	Number of bolt holes n_a	External hole diameter B/M [mm]	Number of bolt holes n_i	Internal hole diameter B/M [mm]	Thread depth t [mm]	Number of grease nipples n_1	Diameter O [mm]	Diameter U [mm]	Diameter A [mm]	Diameter C [mm]	Distance at bottom outer ring/inner ring H_u [mm]	Distance at top outer ring/inner ring H_o [mm]	Gear P.C.D.					Permissible tangential forces normal [kN]	Permissible tangential forces maximum [kN]	Bearing clearances ① axial a. radial [mm]	Curves					
																				d [mm]	m [mm]	z	b [mm]	$k \cdot m$ [mm]									
230.21.0475.013 Typ 21/520.0	414	23,4	517 -0,11	305 +0,08	56	490	332	8	18	12	18	-	4	412,5	415,5	453	375	10,5	10,5	-	-	-	-	-	-	-	-	-	-	-	-	≥ 0 to 0,03	⑤
230.21.0575.013 Typ 21/650.0	544	31,0	647 -0,13	435 +0,10	56	620	462	10	18	14	18	-	4	542,5	545,5	583	505	10,5	10,5	-	-	-	-	-	-	-	-	-	-	-	≥ 0 to 0,03	⑥	
230.21.0675.013 Typ 21/750.0	644	36,4	747 -0,13	535 +0,11	56	720	562	12	18	16	18	-	4	642,5	645,5	683	605	10,5	10,5	-	-	-	-	-	-	-	-	-	-	-	≥ 0 to 0,04	⑦	
230.21.0775.013 Typ 21/850.0	744	42,8	847 -0,14	635 +0,13	56	820	662	12	18	16	18	-	4	742,5	745,5	783	705	10,5	10,5	-	-	-	-	-	-	-	-	-	-	-	≥ 0 to 0,04	⑧	
230.21.0875.013 Typ 21/950.0	844	47,8	947 -0,14	735 +0,13	56	920	762	14	18	18	18	-	4	842,5	845,5	883	805	10,5	10,5	-	-	-	-	-	-	-	-	-	-	-	≥ 0 to 0,05	⑨	
230.21.0975.013 Typ 21/1050.0	944	53,1	1047 -0,17	835 +0,14	56	1020	862	16	18	20	18	-	4	942,5	945,5	983	905	10,5	10,5	-	-	-	-	-	-	-	-	-	-	-	≥ 0 to 0,05	⑩	
230.21.1075.013 Typ 21/1200.0	1094	61,9	1197 -0,17	985 +0,14	56	1170	1012	16	18	20	18	-	4	1092,5	1095,5	1133	1055	10,5	10,5	-	-	-	-	-	-	-	-	-	-	-	≥ 0 to 0,06	⑪	

① Axial clearance = tilting clearance

Bearings with external gear

231.21.0475.013 Typ 21/520.1	414	29,3	504	305 +0,08	56	455	332	10	M 12	12	18	20	4	412,5	417 +0,10	-	375	10,5	-	495	5	99	45,5	-0,5	11,75	23,50	≥ 0 to 0,03	⑤
231.21.0575.013 Typ 21/650.1	544	39,5	640,8	435 +0,10	56	585	462	14	M 12	14	18	20	4	542,5	547 +0,11	-	505	10,5	-	630	6	105	45,5	-0,6	14,20	28,40	≥ 0 to 0,03	⑥
231.21.0675.013 Typ 21/750.1	644	47,6	742,8	535 +0,11	56	685	562	16	M 12	16	18	20	4	642,5	647 +0,13	-	605	10,5	-	732	6	122	45,5	-0,6	14,20	28,40	≥ 0 to 0,04	⑦
231.21.0775.013 Typ 21/850.1	744	53,5	838,8	635 +0,13	56	785	662	18	M 12	16	18	20	4	742,5	747 +0,13	-	705	10,5	-	828	6	138	45,5	-0,6	14,20	28,40	≥ 0 to 0,04	⑧
231.21.0875.013 Typ 21/950.1	844	65,1	950,4	735 +0,13	56	885	762	18	M 12	18	18	20	4	842,5	847 +0,14	-	805	10,5	-	936	8	117	45,5	-0,8	18,93	37,86	≥ 0 to 0,05	⑨
231.21.0975.013 Typ 21/1050.1	944	69,6	1046,4	835 +0,14	56	985	862	20	M 12	20	18	20	4	942,5	947 +0,14	-	905	10,5	-	1032	8	129	45,5	-0,8	18,93	37,86	≥ 0 to 0,05	⑩
231.21.1075.013 Typ 21/1200.1	1094	83,0	1198,4	985 +0,14	56	1135	1012	22	M 12	20	18	20	4	1092,5	1097 +0,17	-	1055	10,5	-	1184	8	148	45,5	-0,8	18,93	37,86	≥ 0 to 0,06	⑪

▲ New αD_a off 1991 addendum reduction 0,1 · m

① Axial clearance = tilting clearance

Bearings with internal gear

232.21.0475.013 Typ 21/520.2	414	27,1	517 -0,11	326,5	56	490	375	8	18	12	M 12	20	4	411 -0,10	415,5	453	-	10,5	-	335	5	67	45,5	-0,75	13,54	27,08	≥ 0 to 0,03	⑤
232.21.0575.013 Typ 21/650.2	544	36,9	647 -0,13	445,2	56	620	505	10	18	16	M 12	20	4	541 -0,11	545,5	583	-	10,5	-	456	6	76	45,5	-0,6	16,00	32,00	≥ 0 to 0,03	⑥
232.21.0675.013 Typ 21/750.2	644	43,7	747 -0,13	547,2	56	720	605	12	18	18	M 12	20	4	641 -0,13	645,5	683	-	10,5	-	558	6	93	45,5	-0,6	15,62	31,24	≥ 0 to 0,04	⑦
232.21.0775.013 Typ 21/850.2	744	51,1	847 -0,14	649,2	56	820	705	12	18	20	M 12	20	4	741 -0,13	745,5	783	-	10,5	-	660	6	110	45,5	-0,6	15,32	30,64	≥ 0 to 0,04	⑧
232.21.0875.013 Typ 21/950.2	844	61,6	947 -0,14	737,6	56	920	805	14	18	20	M 12	20	4	841 -0,14	845,5	883	-	10,5	-	752	8	94	45,5	-0,8	20,80	41,60	≥ 0 to 0,05	⑨
232.21.0975.013 Typ 21/1050.2	944	65,8	1047 -0,17	841,6	56	1020	905	16	18	22	M 12	20	4	941 -0,14	945,5	983	-	10,5	-	856	8	107	45,5	-0,8	20,49	40,98	≥ 0 to 0,05	⑩
232.21.1075.013 Typ 21/1200.2	1094	80,7	1197 -0,17	985,6	56	1170	1055	16	18	24	M 12	20	4	1091 -0,17	1095,5	1133	-	10,5	-	1000	8	125	45,5	-0,8	20,16	40,32	≥ 0 to 0,06	⑪

① Axial clearance = tilting clearance

Standard series KD 210

Standard bearing type 21, Bearing with limited clearance

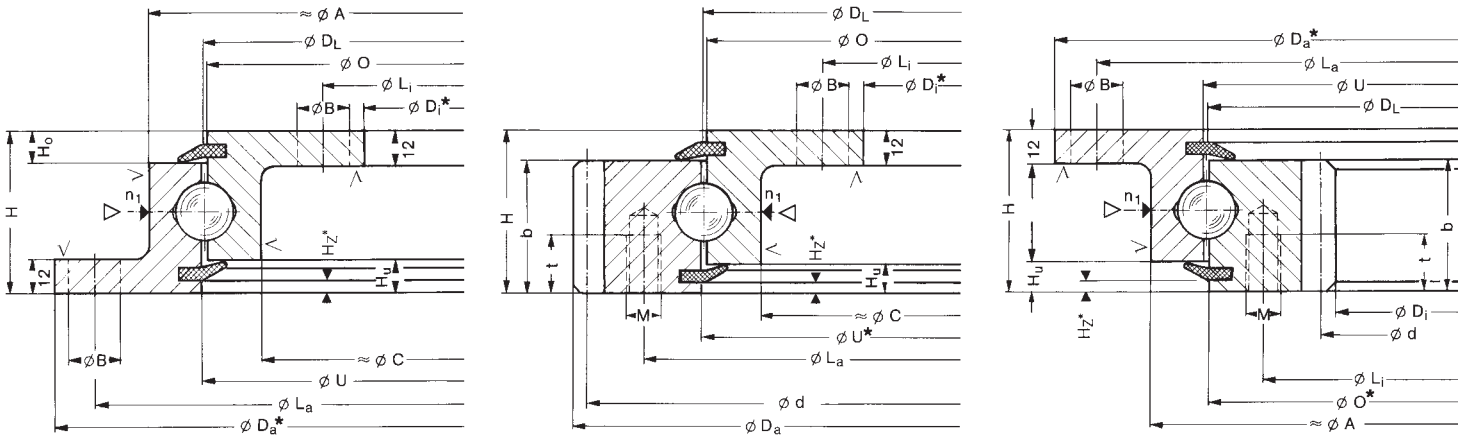

- ▶ $n_1 = 4$ Conical grease nipple
AM 8 x 1 DIN 71412
= equispaced
With ungeared bearings
the grease nipples may be
located on the inner ring,
if requested.
- △ = Filler plug
- √ = $\sqrt{\text{rolled}}$

Pilot height $H_z^* = 4.5$ mm
Pilot height of companion structure = $(H_z - 1)$ mm

Static limiting load curves

———— Raceway - - - - Bolts

For loads exceeding the limiting load curves for the bolts,
the number of fastening bolts must be doubled.

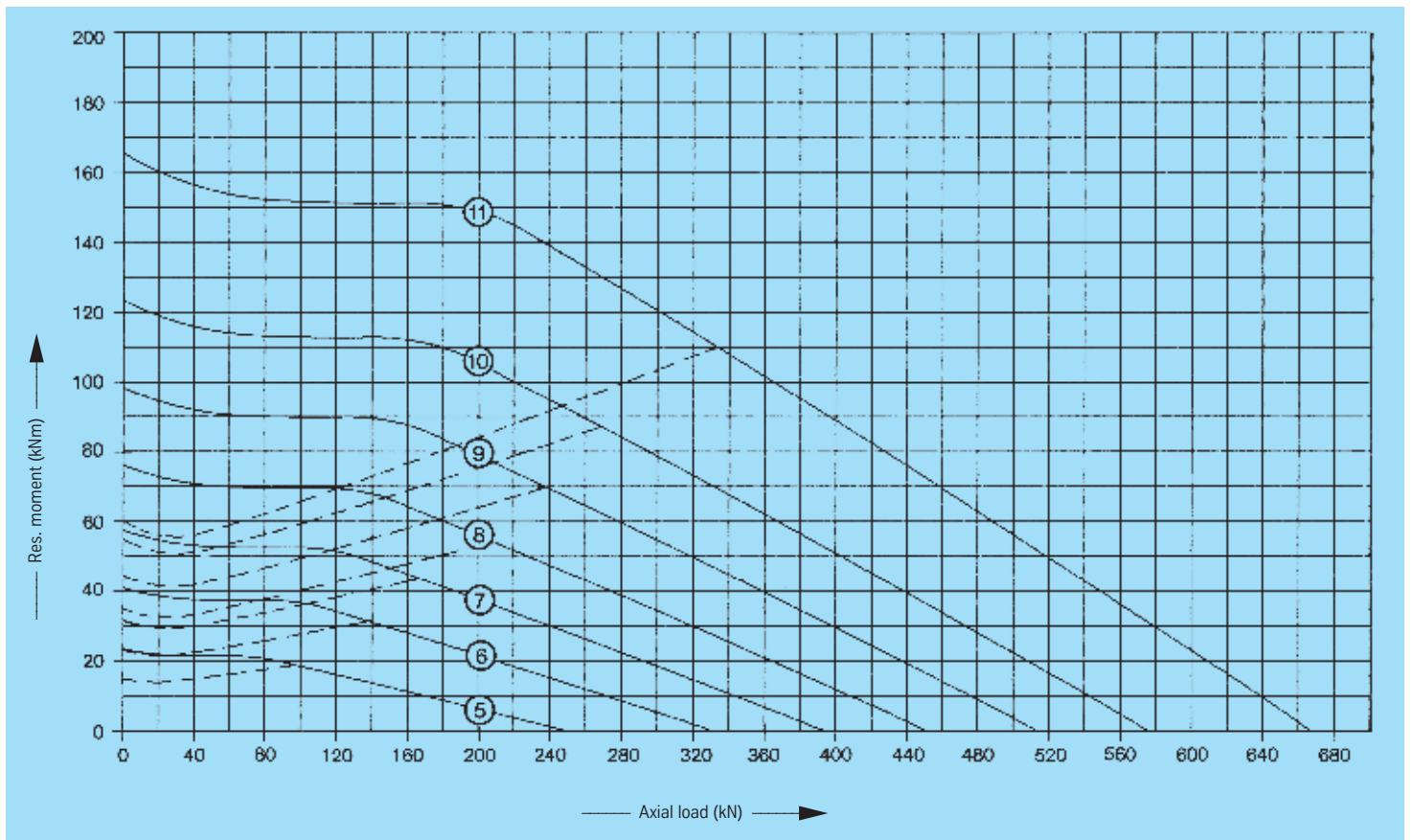

Standard series KD 210

Standard bearings type 110, standard bearing



Rothe Erde
Slewring Bearings

Bearing ungeared

Drawing No.	Ball track diameter D_L [mm]	Weight [kg]	Outer diameter (O.D.) D_a [mm]	Inner diameter (I.D.) D_i [mm]	Overall height H [mm]	External bolt circle diameter L_a [mm]	Internal bolt circle diameter L_i [mm]	Number of bolt holes n_a	External hole diameter B/M [mm]	Number of bolt holes n_i	Internal hole diameter B/M [mm]	Thread depth t [mm]	Number of grease nipples n_1	Diameter O [mm]	Diameter U [mm]	Diameter A [mm]	Diameter C [mm]	Distance at bottom outer ring/inner ring H_u [mm]	Distance at top outer ring/inner ring H_o [mm]	Gear P.C.D. d [mm]	Module m [mm]	Number of teeth z	Tooth width b [mm]	Addendum reduction $k \cdot m$ [mm]	Permissible tangential forces normal [kN]	Permissible tangential forces maximum [kN]	Bearing clearances ①		Curves		
																											axial [mm]	radial [mm]			
280.30.0900.013 Typ 110/1100.0	955	131	1100	805	90	1060	845	30	22	30	22	-	6	956,5	953,5	1017	893	19	19	-	-	-	-	-	-	-	-	-	≤ 0,4	≤ 0,31	19
280.30.1000.013 Typ 110/1200.0	1055	145	1200	905	90	1160	945	30	22	30	22	-	6	1056,5	1053,5	1117	993	19	19	-	-	-	-	-	-	-	-	-	≤ 0,4	≤ 0,31	20
280.30.1100.013 Typ 110/1300.0	1155	159	1300	1005	90	1260	1045	36	22	36	22	-	6	1156,5	1153,5	1217	1093	19	19	-	-	-	-	-	-	-	-	≤ 0,4	≤ 0,31	21	
280.30.1200.013 Typ 110/1400.0	1255	172	1400	1105	90	1360	1145	42	22	42	22	-	6	1256,5	1253,5	1317	1193	19	19	-	-	-	-	-	-	-	-	≤ 0,45	≤ 0,37	22	
280.30.1300.013 Typ 110/1500.0	1355	186	1500	1205	90	1460	1245	42	22	42	22	-	6	1356,5	1353,5	1417	1293	19	19	-	-	-	-	-	-	-	-	≤ 0,45	≤ 0,37	23	
280.30.1400.013 Typ 110/1600.0	1455	200	1600	1305	90	1560	1345	48	22	48	22	-	6	1456,5	1453,5	1517	1393	19	19	-	-	-	-	-	-	-	-	≤ 0,45	≤ 0,37	24	

① Axial clearance = tilting clearance

Bearings with external gear

281.30.0900.013 Typ 110/1100.1	955	165	1096,2	805	90	1016	845	30	M 20	30	22	40	6	956,5	953,5	-	893	19	-	1080	9	120	71	-0,9	33,23	66,46	≤ 0,4	≤ 0,31	19
281.30.1000.013 Typ 110/1200.1	1055	183	1198	905	90	1116	945	30	M 20	30	22	40	6	1056,5	1053,5	-	993	19	-	1180	10	118	71	-1	36,92	73,84	≤ 0,4	≤ 0,31	20
281.30.1100.013 Typ 110/1300.1	1155	200	1298	1005	90	1216	1045	36	M 20	36	22	40	6	1156,5	1153,5	-	1093	19	-	1280	10	128	71	-1	36,92	73,84	≤ 0,4	≤ 0,31	21
281.30.1200.013 Typ 110/1400.1	1255	216	1398	1105	90	1316	1145	42	M 20	42	22	40	6	1256,5	1253,5	-	1193	19	-	1380	10	138	71	-1	36,92	73,84	≤ 0,45	≤ 0,37	22
281.30.1300.013 Typ 110/1500.1	1355	234	1498	1205	90	1416	1245	42	M 20	42	22	40	6	1356,5	1353,5	-	1293	19	-	1480	10	148	71	-1	36,92	73,84	≤ 0,45	≤ 0,37	23
281.30.1400.013 Typ 110/1600.1	1455	250	1598	1305	90	1516	1345	48	M 20	48	22	40	6	1456,5	1453,5	-	1393	19	-	1580	10	158	71	-1	36,92	73,84	≤ 0,45	≤ 0,37	24

▲ New ϕD_a off 1991 addendum reduction 0,1 · m

① Axial clearance = tilting clearance

Bearings with internal gear

282.30.0900.013 Typ 110/1100.2	955	159	1100	812	90	1060	894	30	22	30	M 20	40	6	956,5	953,5	1017	-	19	-	830	10	83	71	-1	41,18	82,36	≤ 0,4	≤ 0,31	19
282.30.1000.013 Typ 110/1200.2	1055	176	1200	912	90	1160	994	30	22	30	M 20	40	6	1056,5	1053,5	1117	-	19	-	930	10	93	71	-1	40,63	81,26	≤ 0,4	≤ 0,31	20
282.30.1100.013 Typ 110/1300.2	1155	192	1300	1012	90	1260	1094	36	22	36	M 20	40	6	1156,5	1153,5	1217	-	19	-	1030	10	103	71	-1	40,15	80,30	≤ 0,4	≤ 0,31	21
282.30.1200.013 Typ 110/1400.2	1255	208	1400	1112	90	1360	1194	42	22	42	M 20	40	6	1256,5	1253,5	1317	-	19	-	1130	10	113	71	-1	39,74	79,48	≤ 0,45	≤ 0,37	22
282.30.1300.013 Typ 110/1500.2	1355	226	1500	1212	90	1460	1294	42	22	42	M 20	40	6	1356,5	1353,5	1417	-	19	-	1230	10	123	71	-1	39,39	78,78	≤ 0,45	≤ 0,37	23
282.30.1400.013 Typ 110/1600.2	1455	243	1600	1310	90	1560	1394	48	22	48	M 20	40	6	1456,5	1453,5	1517	-	19	-	1330	10	133	71	-	39,10	78,20	≤ 0,45	≤ 0,37	24

① Axial clearance = tilting clearance

Standard series KD 210

Standard bearings type 110, standard bearing



*If pilots are required on **standard bearings**, it is **essential** that this is indicated at the time of ordering.
Pilots can only be provided at **nominal diameters** marked with an *.

Pilot tolerances:		Outside	Inside
Type 110/1100 110/1300		-0.25 mm	+0.25 mm
Type 110/1400 110/1600		-0.30 mm	+0.30 mm

Pilot height $H_z = 13$ mm
Pilot height of companion structure = $(H_z - 1)$ mm

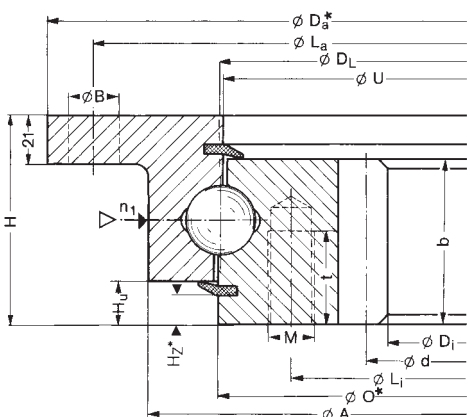
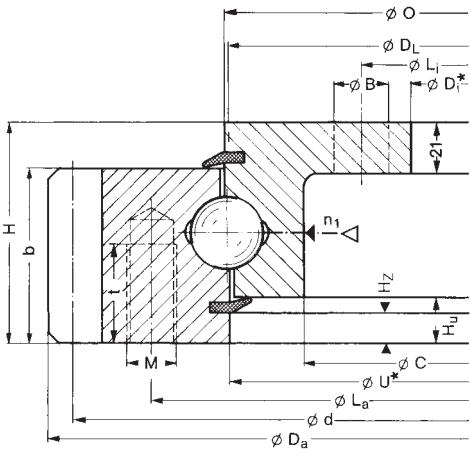
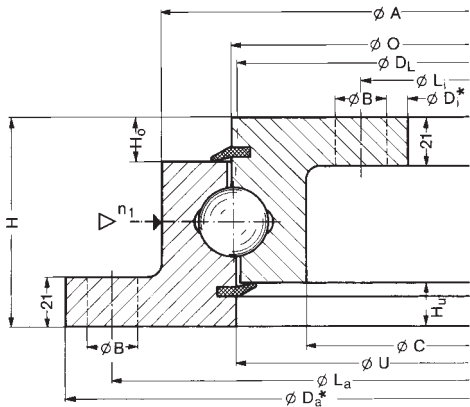

Static limiting load curves

—— Raceway - - - Bolts

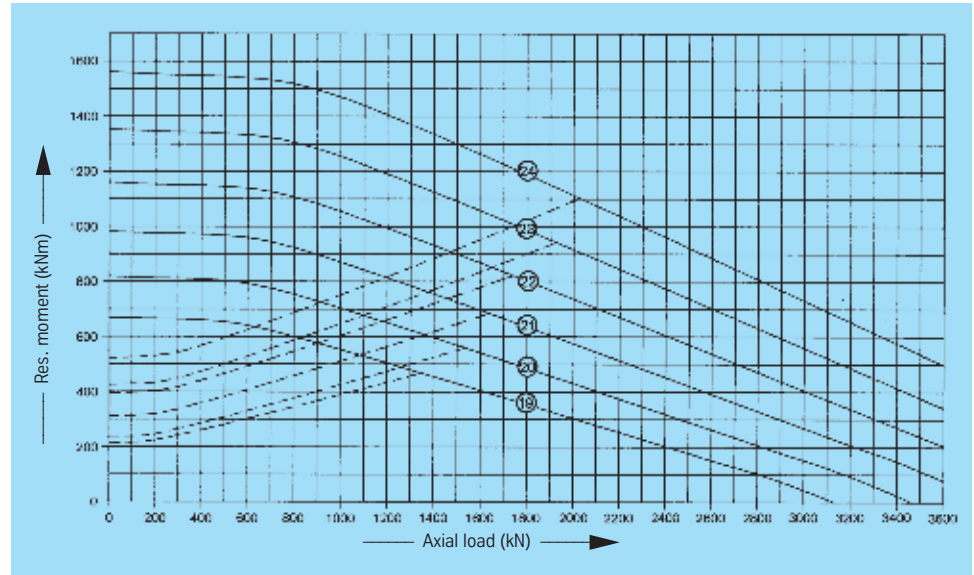

- ▶ n_1 = Conical grease nipple
AM 8 x 1 DIN 71412
= equispaced
With ungeared bearings
the grease nipples may be
located on the inner ring,
if requested.
- ▽ = Filler plug

Raceway reference loads or static limiting load curves and service life curves must be determined using the load factors shown in the Table 1 on Page 11.

Service life curves · 30,000 revolutions

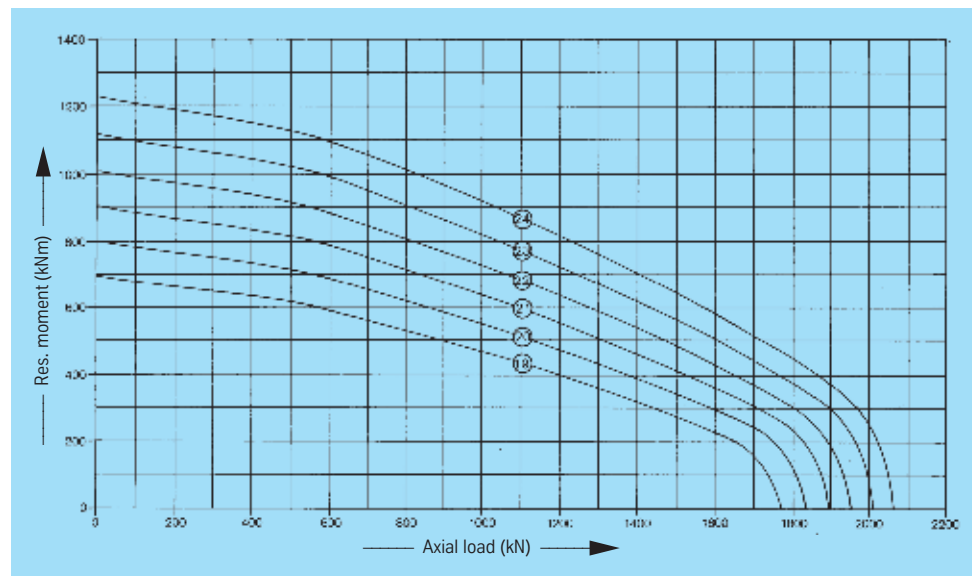

Standard series KD 210

Standard bearing type 110, Bearing with limited clearance



Rothe Erde
Slewing Bearings

Bearing ungeared

Drawing No.	Ball track diameter D_L [mm]	Weight [kg]	Outer diameter (O.D.) D_a [mm]	Inner diameter (I.D.) D_i [mm]	Overall height H [mm]	External bolt circle diameter L_a [mm]	Internal bolt circle diameter L_i [mm]	Number of bolt holes n_a	External hole diameter B/M [mm]	Number of bolt holes n_i	Internal hole diameter B/M [mm]	Thread depth t [mm]	Number of grease nipples n_1	Diameter O [mm]	Diameter U [mm]	Diameter A [mm]	Diameter C [mm]	Distance at bottom outer ring/inner ring H_u [mm]	Distance at top outer ring/inner ring H_o [mm]	Gear P.C.D. d [mm]	Module m [mm]	Number of teeth z	Tooth width b [mm]	Addendum reduction $k \cdot m$ [mm]	Permissible tangential forces normal [kN]	Permissible tangential forces maximum [kN]	Bearing clearances ① axial a. radial [mm]	Curves		
																													axial a. radial	
280.30.0975.013 Typ 110/1100.0	955	131	1098 -0,17	807 +0,14	90	1060	845	30	22	30	22	-	6	956,5	953,5	1017	893	19	19	-	-	-	-	-	-	-	-	-	≥ 0 to 0,06	19
280.30.1075.013 Typ 110/1200.0	1055	145	1198 -0,17	907 +0,14	90	1160	945	30	22	30	22	-	6	1056,5	1053,5	1117	993	19	19	-	-	-	-	-	-	-	-	-	≥ 0 to 0,06	20
280.30.1175.013 Typ 110/1300.0	1155	159	1298 -0,20	1007 +0,17	90	1260	1045	36	22	36	22	-	6	1156,5	1153,5	1217	1093	19	19	-	-	-	-	-	-	-	-	-	≥ 0 to 0,06	21
280.30.1275.013 Typ 110/1400.0	1255	172	1398 -0,20	1107 +0,17	90	1360	1145	42	22	42	22	-	6	1256,5	1253,5	1317	1193	19	19	-	-	-	-	-	-	-	-	-	≥ 0 to 0,07	22
280.30.1375.013 Typ 110/1500.0	1355	186	1498 -0,20	1207 +0,17	90	1460	1245	42	22	42	22	-	6	1356,5	1353,5	1417	1293	19	19	-	-	-	-	-	-	-	-	-	≥ 0 to 0,07	23
280.30.1475.013 Typ 110/1600.0	1455	200	1598 -0,20	1307 +0,20	90	1560	1345	48	22	48	22	-	6	1456,5	1453,5	1517	1393	19	19	-	-	-	-	-	-	-	-	-	≥ 0 to 0,07	24

① Axial clearance = tilting clearance

Bearings with external gear

281.30.0975.013 Typ 110/1100.1	955	165	1096,2 +0,14	807 +0,14	90	1016	845	30	M 20	30	22	40	6	956,5	955 +0,14	-	893	19	-	1080	9	120	71	-0,9	33,23	66,46	≥ 0 to 0,06	19
281.30.1075.013 Typ 110/1200.1	1055	183	1198 +0,14	907 +0,14	90	1116	945	30	M 20	30	22	40	6	1056,5	1055 +0,17	-	993	19	-	1180	10	118	71	-1	36,92	73,84	≥ 0 to 0,06	20
281.30.1175.013 Typ 110/1300.1	1155	200	1298 +0,17	1007 +0,17	90	1216	1045	36	M 20	36	22	40	6	1156,5	1155 +0,17	-	1093	19	-	1280	10	128	71	-1	36,92	73,84	≥ 0 to 0,06	21
281.30.1275.013 Typ 110/1400.1	1255	216	1398 +0,17	1107 +0,17	90	1316	1145	42	M 20	42	22	40	6	1256,5	1255 +0,20	-	1193	19	-	1380	10	138	71	-1	36,92	73,84	≥ 0 to 0,07	22
281.30.1375.013 Typ 110/1500.1	1355	234	1498 +0,17	1207 +0,17	90	1416	1245	42	M 20	42	22	40	6	1356,5	1355 +0,20	-	1293	19	-	1480	10	148	71	-1	36,92	73,84	≥ 0 to 0,07	23
281.30.1475.013 Typ 110/1600.1	1455	250	1598 +0,20	1307 +0,20	90	1516	1345	48	M 20	48	22	40	6	1456,5	1455 +0,20	-	1393	19	-	1580	10	158	71	-1	36,92	73,84	≥ 0 to 0,07	24

▲ New ϕD_a off 1991 addendum reduction 0,1 · m

① Axial clearance = tilting clearance

Bearings with internal gear

282.30.0975.013 Typ 110/1100.2	955	159	1098 -0,17	812	90	1060	894	30	22	30	M 20	40	6	955 -0,14	953,5	1017	-	19	-	830	10	83	71	-1	41,18	82,36	≥ 0 to 0,06	19
282.30.1075.013 Typ 110/1200.2	1055	176	1198 -0,17	912	90	1160	994	30	22	30	M 20	40	6	1055 -0,17	1053,5	1117	-	19	-	930	10	93	71	-1	40,63	81,26	≥ 0 to 0,06	20
282.30.1175.013 Typ 110/1300.2	1155	192	1298 -0,20	1012	90	1260	1094	36	22	36	M 20	40	6	1155 -0,17	1153,5	1217	-	19	-	1030	10	103	71	-1	40,15	80,30	≥ 0 to 0,06	21
282.30.1275.013 Typ 110/1400.2	1255	208	1398 -0,20	1112	90	1360	1194	42	22	42	M 20	40	6	1255 -0,20	1253,5	1317	-	19	-	1130	10	113	71	-1	39,74	79,48	≥ 0 to 0,07	22
282.30.1375.013 Typ 110/1500.2	1355	226	1498 -0,20	1212	90	1460	1294	42	22	42	M 20	40	6	1355 -0,20	1353,5	1417	-	19	-	1230	10	123	71	-1	39,39	78,78	≥ 0 to 0,07	23
282.30.1475.013 Typ 110/1600.2	1455	243	1598 -0,20	1310	90	1560	1394	48	22	48	M 20	40	6	1455 -0,20	1453,5	1517	-	19	-	1330	10	133	71	-	39,10	78,20	≥ 0 to 0,07	24

① Axial clearance = tilting clearance

Standard series KD 210

Standard bearing type 110, Bearing with limited clearance



Rothe Erde
Slewing Bearings

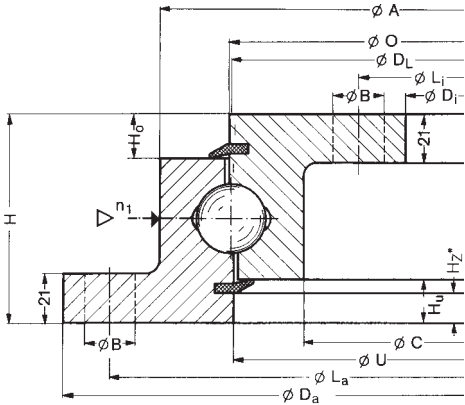

Static limiting load curves

—— Raceway - - - Bolts

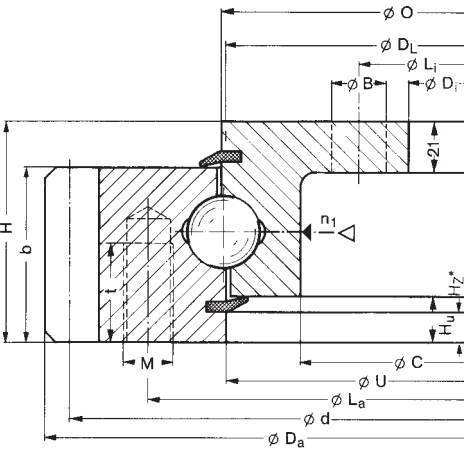
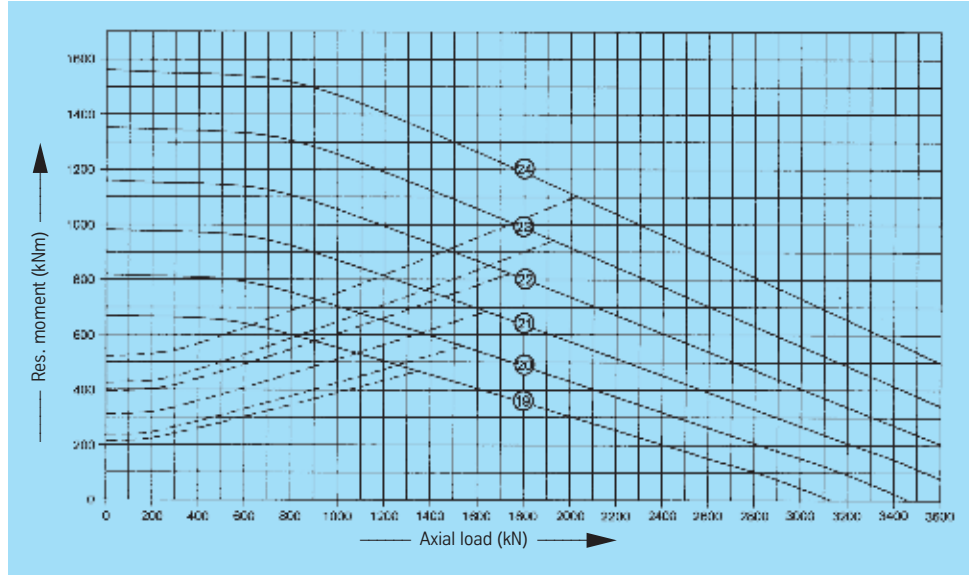

Pilot height $H_2^* = 13$ mm
Pilot height of companion structure = $(H_2 - 1)$ mm

- ▶ n_1 = Conical grease nipple
AM 8 x 1 DIN 71412
≈ equispaced
With ungeared bearings
the grease nipples may be
located on the inner ring,
if requested.
- ▽ = Filler plug

Raceway reference loads or static limiting load curves and service life curves must be determined using the load factors shown in the Table 1 on Page 11.

Service life curves · 30,000 revolutions

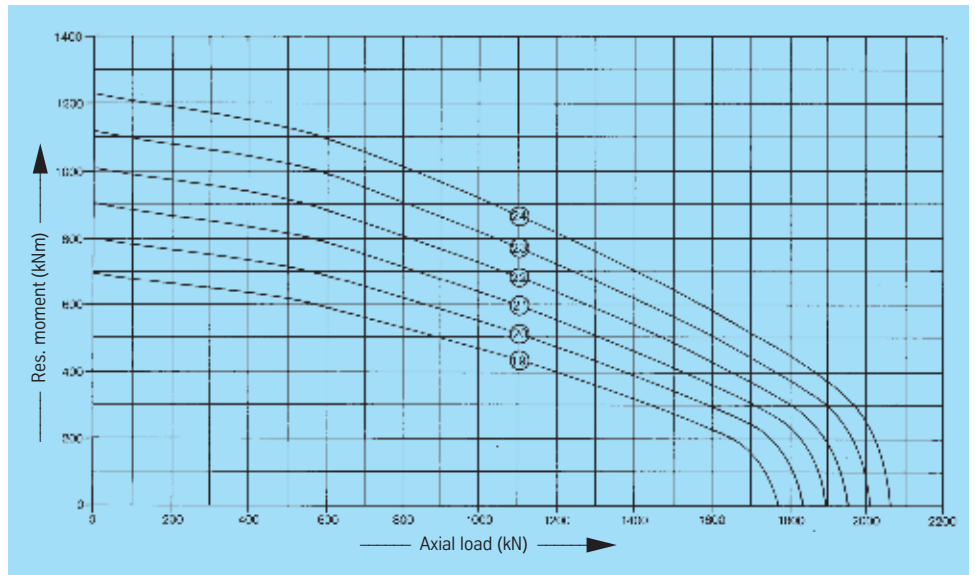
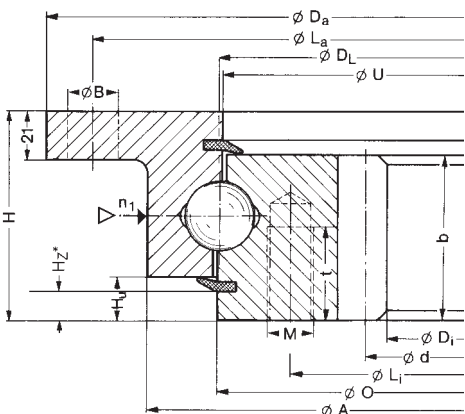



Rothe Erde
Slewing Bearings

Standard series KD 320

Double-row ball bearing slewing rings

Double-axial ball bearings

Pages 57 – 83

External gear
Internal gear

Pages 58 – 69
Pages 70 – 83

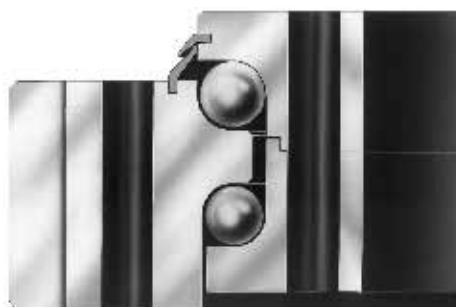

Standard series KD 320



Rothe Erde
Slewring Bearings

Bearings with external gear

Drawing No. Ball track dia. D_L [mm]	Weight [kg]	Outer diameter (O.D.) D_o [mm]	Inner diameter (I.D.) D_i [mm]	Overall height H [mm]	External bolt circle dia. L_e [mm] L_i [mm]		Number of bolt holes per hole circle n	Bolt hole diameter B [mm]	Bolt size M [mm]	Number of grease nipples per level n_1	Diameter O [mm]	Diameter U [mm]	Ring height H_1 [mm]	Ring height H_2 [mm]	Distance at bottom Outer ring/inner ring H_b [mm]	Distance at top Outer ring/inner ring H_o [mm]	Gear P.C.D. d [mm]	Module m [mm]	Number of teeth z	Addendum modification sign per DIN 3960 October, 1976 $x \cdot m$ [mm]	Addendum reduction $k \cdot m$ [mm]	Tooth width b [mm]	Permissible tangential forces, normal [kN]	Permissible tangential forces, maximum [kN]	Curves
011.20.0755.000.11.1504 011.20.0755.001.21.1504	101	862,8	679	82	800	706	24	17,5	16	2	797	771	58	78	4	24	852	6	142	+0,0	-0,6	50	15,60 24,00	31,20 48,00	①
011.20.0971.000.11.1504 011.20.0971.001.21.1504	128	1078,4	895	82	1015	922	30	17,5	16	2	1012	987	58	78	4	24	1064	8	133	+0,0	-0,8	50	20,80 32,00	41,60 64,00	②
011.20.1220.000.11.1504 011.20.1220.001.21.1504	178	1342,4	1140	82	1270	1170	48	17,5	16	3	1261	1238	58	78	4	24	1320	8	165	+4,0	-0,8	58	29,15 44,83	58,30 89,66	③
011.20.1385.000.11.1504 011.20.1385.001.21.1504	201	1502,4	1305	82	1435	1335	54	17,5	16	3	1426	1403	58	78	4	24	1480	8	185	+4,0	-0,8	58	29,15 44,83	58,30 89,66	④

Gear normalized
Gear quenched and tempered

Static limiting load curves

—— Raceway - - - Bolts

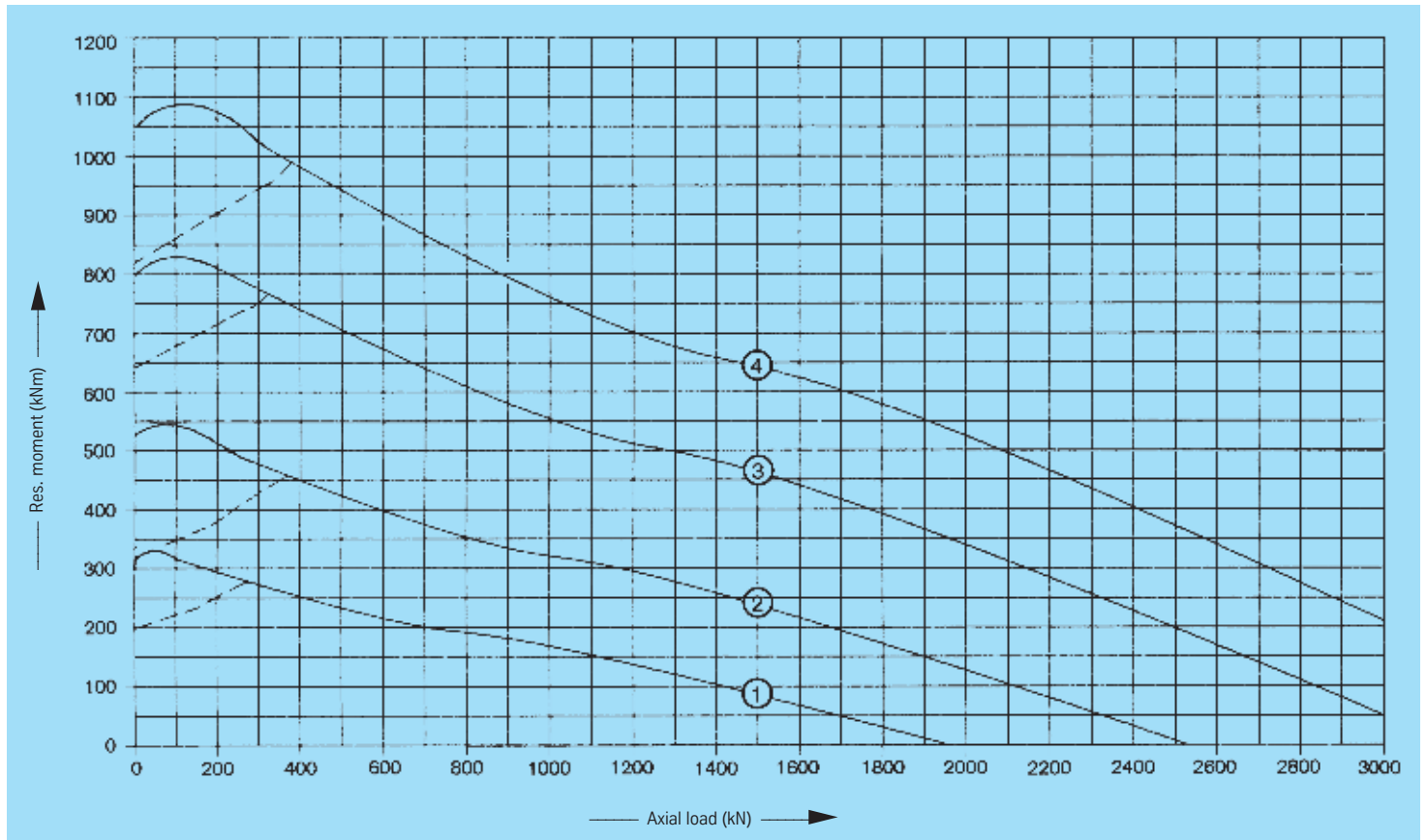

Standard series KD 320



Rothe Erde
Slewing Bearings

Thread depth t [mm]	Tooth neck dia. Z_u [mm]	Tooth neck height h_u [mm]	Curves
35	833	8	①
35	1042	8	②
35	-	-	③
35	-	-	④

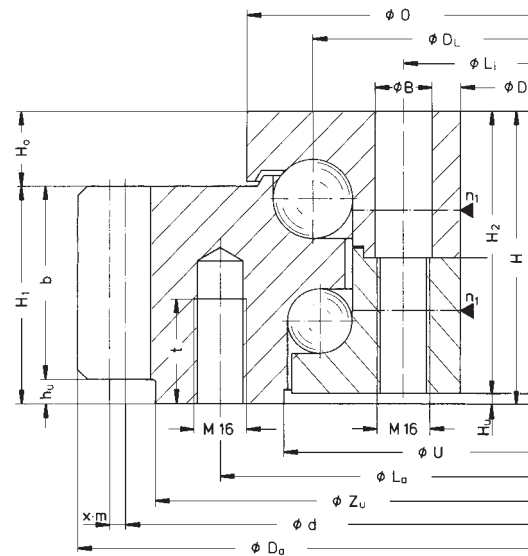

Service life curves · 30,000 revolutions

drawing position = mounting position

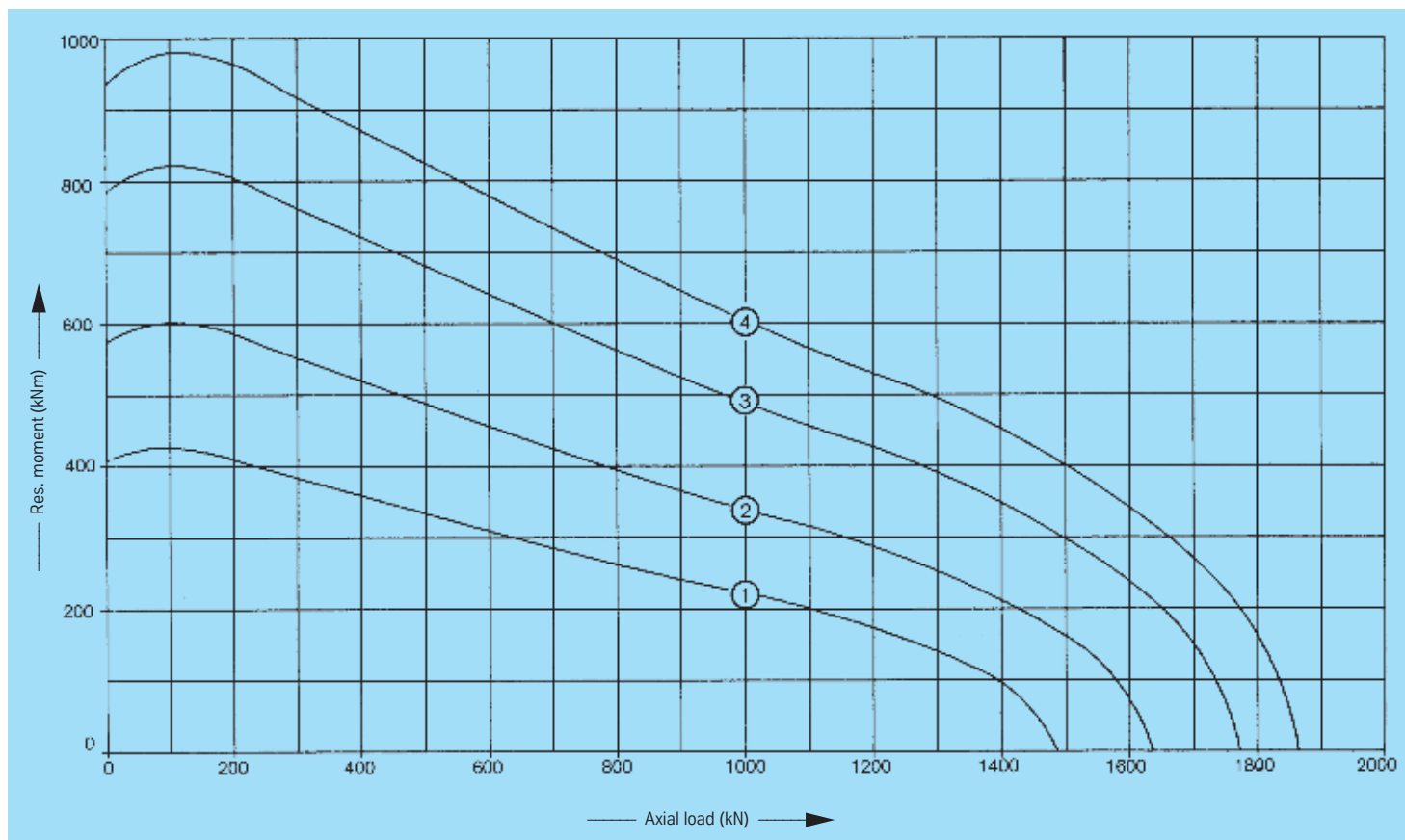

Standard series KD 320



Rothe Erde
Slewing Bearings

Bearings with external gear

Drawing No. Ball track dia. D_L [mm]	Weight [kg]	Outer diameter (O.D.) D_o [mm]	Inner diameter (I.D.) D_i [mm]	Overall height H [mm]	External bolt circle dia. L_e [mm]	Internal bolt circle dia. L_i [mm]	Number of bolt holes per hole circle n	Bolt hole diameter B [mm]	Bolt size M [mm]	Number of grease nipples per level n_1	Diameter O [mm]	Diameter U [mm]	Ring height H_1 [mm]	Ring height H_2 [mm]	Distance at bottom Outer ring/inner ring H_b [mm]	Distance at top Outer ring/inner ring H_o [mm]	Gear P.C.D. d [mm]	Module m [mm]	Number of teeth z	Addendum modification sign per DIN 3960 October, 1976 $x \cdot m$ [mm]	Addendum reduction $k \cdot m$ [mm]	Tooth width b [mm]	Permissible tangential forces, normal [kN]	Permissible tangential forces, maximum [kN]	Curves
011.25.1200.600.11.1503 011.25.1200.601.21.1503	301	1378	1100	102	1290	1135	36	22	20	3	1223	1215	76	96	6	26	1350	10	135	+5,0	-1,0	76	47,70 69,75	95,40 139,50	⑤
011.25.1461.000.11.1503 011.25.1461.001.21.1503	381	1648	1360	102	1555	1395	40	22	20	3	1484	1479	76	96	6	26	1620	10	162	+5,0	-1,0	76	47,70 69,75	95,40 139,50	⑥
011.25.1800.000.11.1503 011.25.1800.001.41.1503	488	2001,6	1700	102	1890	1735	48	22	20	4	1823	1818	76	96	6	26	1968	12	164	+6,0	-1,2	76	57,25 83,71	114,50 167,42	⑦

Gear normalized

Gear quenched and tempered

Static limiting load curves

—— Raceway - - - Bolts

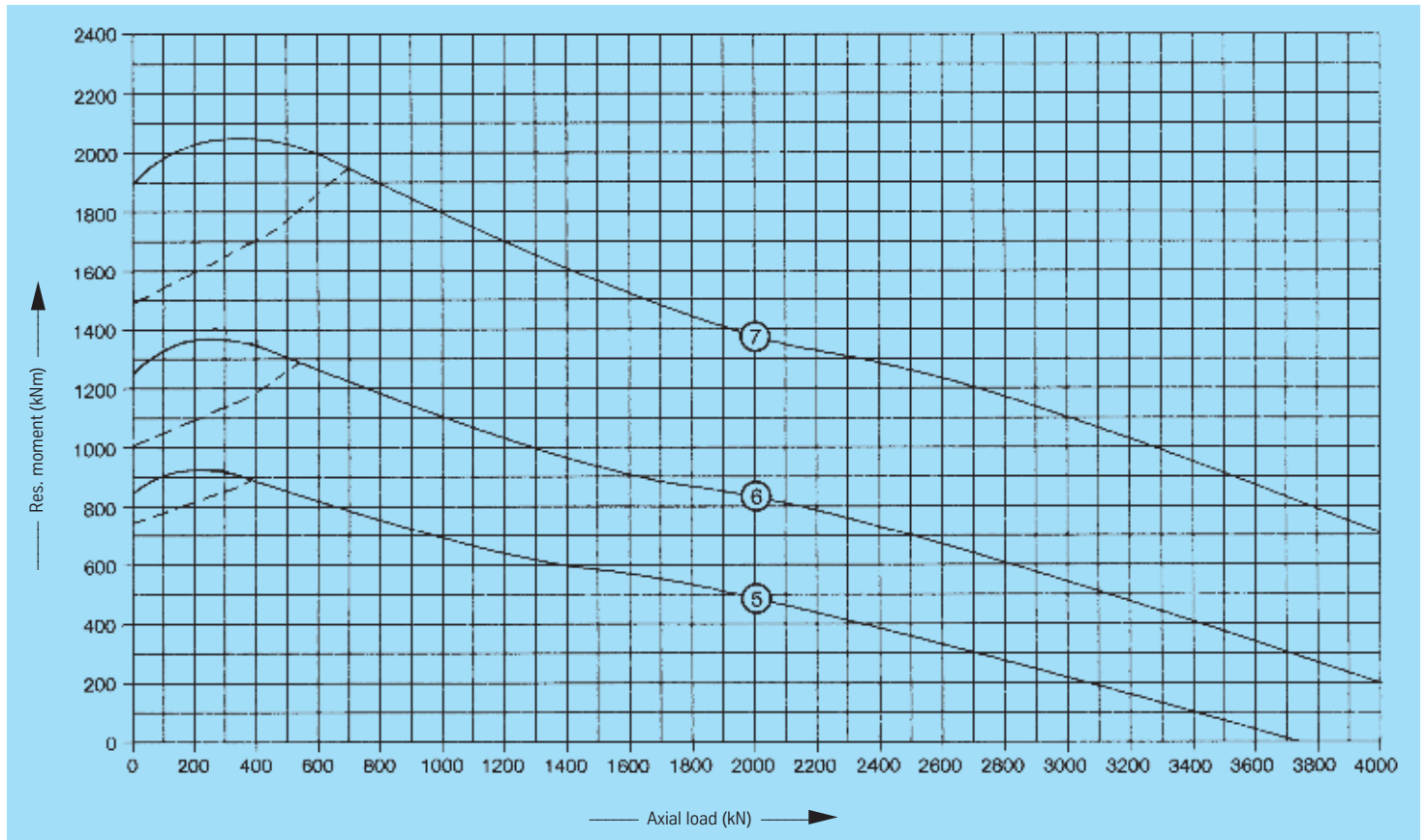

Standard series KD 320



Rothe Erde
Slewing Bearings

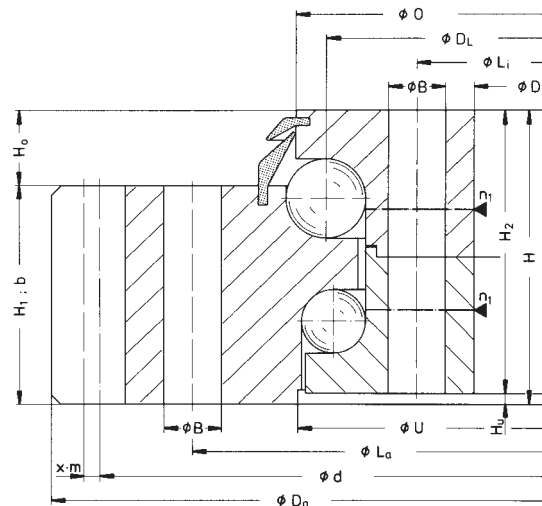

Service life curves · 30,000 revolutions

drawing position = mounting position

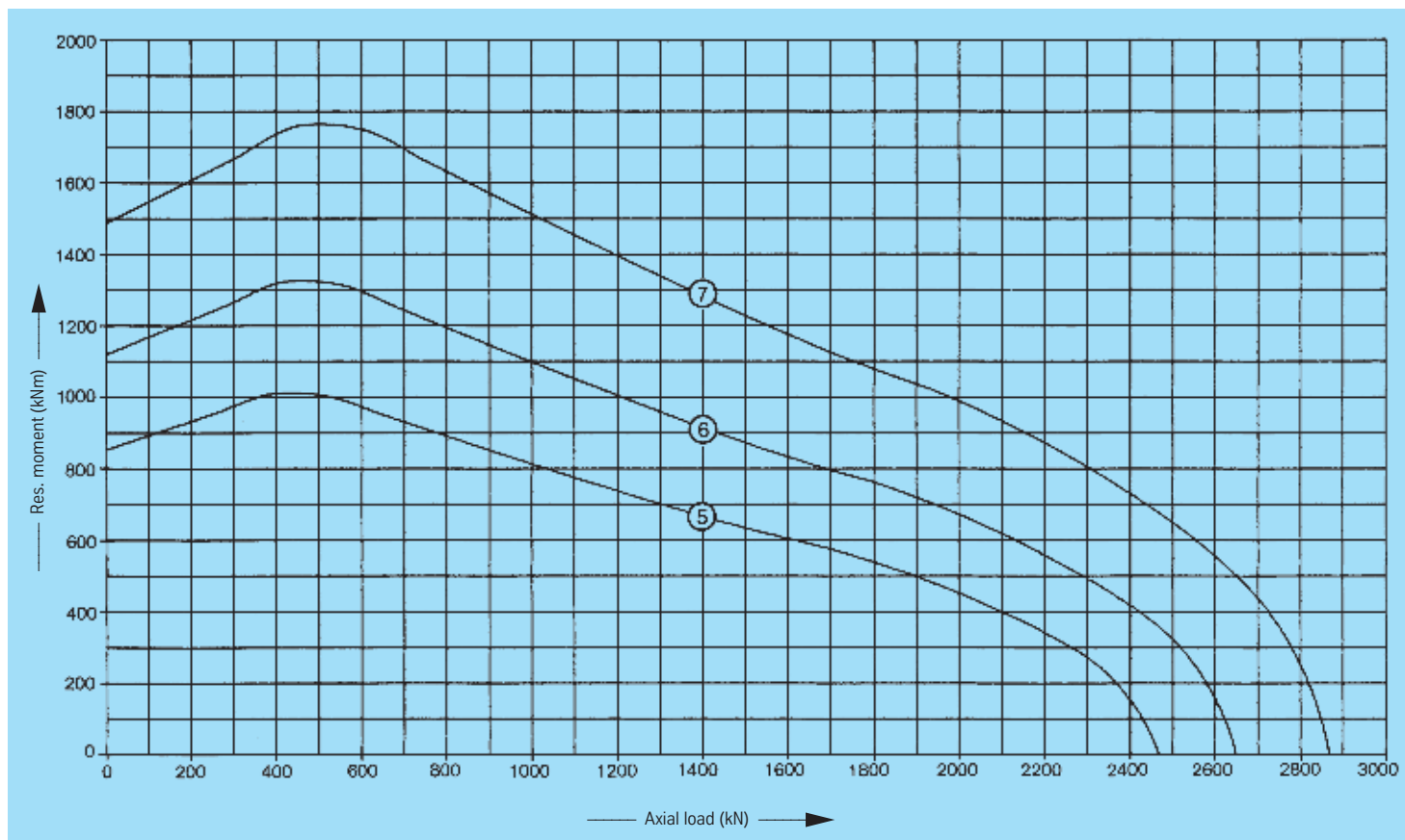

Standard series KD 320



Rothe Erde
Slew Bearings

Bearings with external gear

Drawing No. Ball track dia. D_L [mm]	Weight [kg]	Outer diameter (O.D.) D_o [mm]	Inner diameter (I.D.) D_i [mm]	Overall height H [mm]	External bolt circle dia. L_e [mm]	Internal bolt circle dia. L_i [mm]	Number of bolt holes per hole circle n	Bolt hole diameter B [mm]	Bolt size M [mm]	Number of grease nipples per level n_1	Diameter O [mm]	Diameter U [mm]	Ring height H_1 [mm]	Ring height H_2 [mm]	Distance at bottom Outer ring/inner ring H_b [mm]	Distance at top Outer ring/inner ring H_o [mm]	Gear P.C.D. d [mm]	Module m [mm]	Number of teeth z	Addendum modification sign per DIN 3960 October, 1976 $x \cdot m$ [mm]	Addendum reduction $k \cdot m$ [mm]	Tooth width b [mm]	Permissible tangential forces, normal [kN]	Permissible tangential forces, maximum [kN]	Curves
011.30.1440.190.11.1503 011.30.1440.191.41.1503	520	1653,6	1320	120	1545	1365	36	26	24	3	1469	1460	91	114	6	29	1620	12	135	+6,0	-1,2	91	68,5	137,1	⑧
011.30.1734.000.11.1503 011.30.1734.001.41.1503	636	1953,6	1615	120	1845	1660	44	26	24	3	1763	1757	91	114	6	29	1920	12	160	+6,0	-1,2	91	68,5	137,1	⑨
011.30.2031.600.11.1503 011.30.2031.601.41.1503	755	2253,6	1910	120	2140	1955	48	26	24	4	2060	2054	91	114	6	29	2220	12	185	+6,0	-1,2	91	68,5	137,1	⑩
011.30.2235.000.11.1503 011.30.2235.001.41.1503	827	2457,6	2115	120	2345	2160	52	26	24	4	2264	2258	91	114	6	29	2424	12	202	+6,0	-1,2	91	68,5	137,1	⑪

Gear normalized
Gear quenched and tempered

Static limiting load curves

—— Raceway - - - Bolts

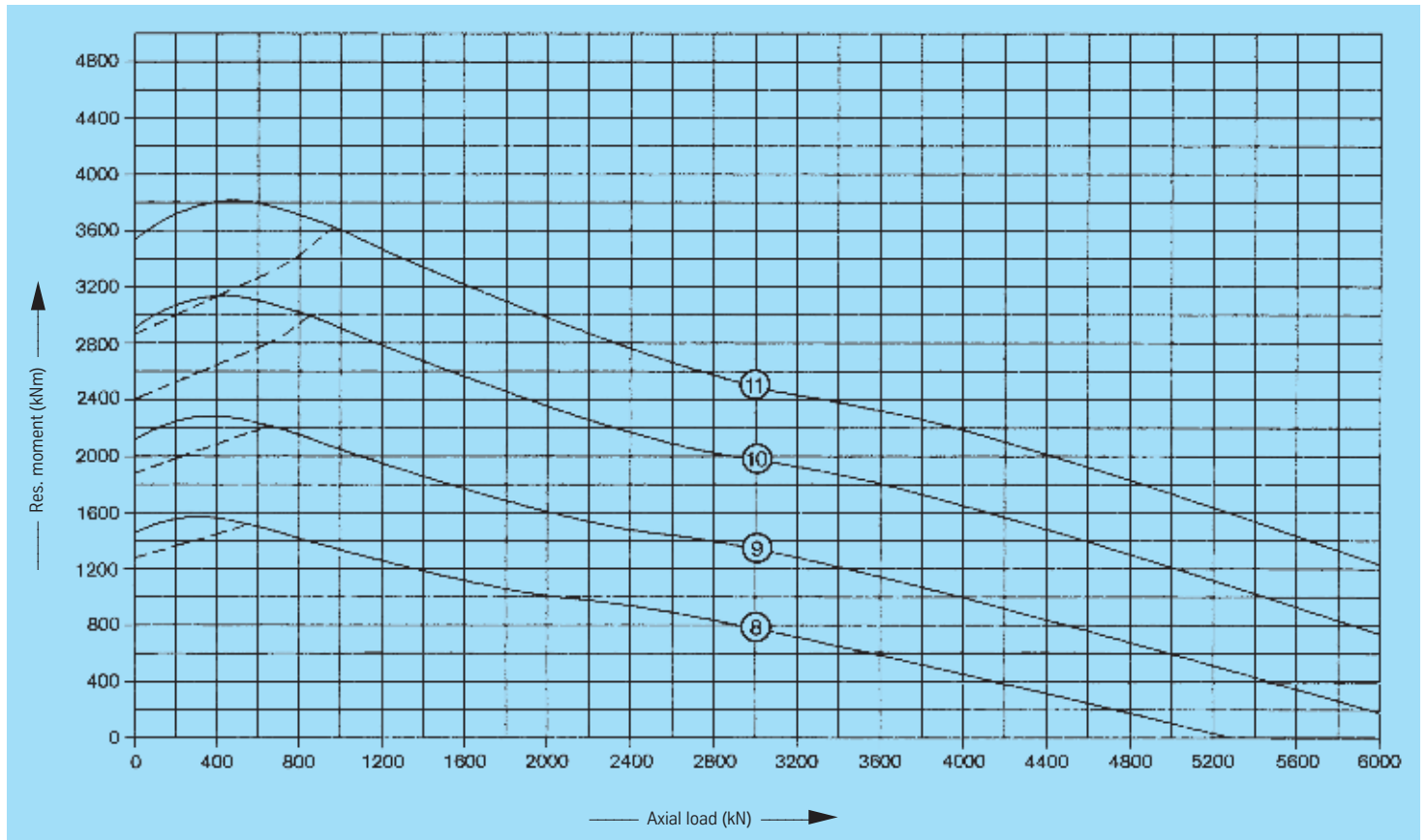

Standard series KD 320



Rothe Erde
Slewing Bearings

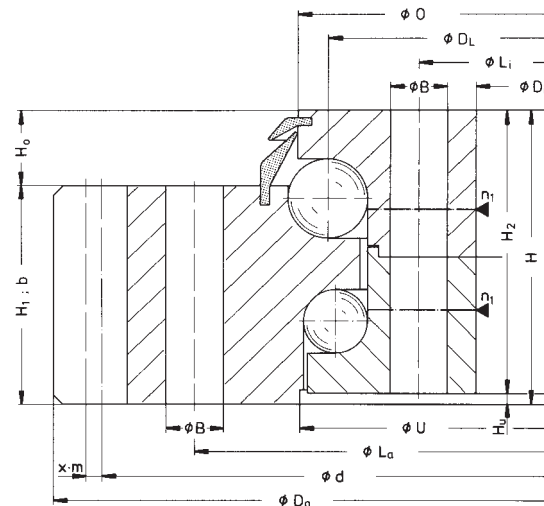

Service life curves · 30,000 revolutions

drawing position = mounting position

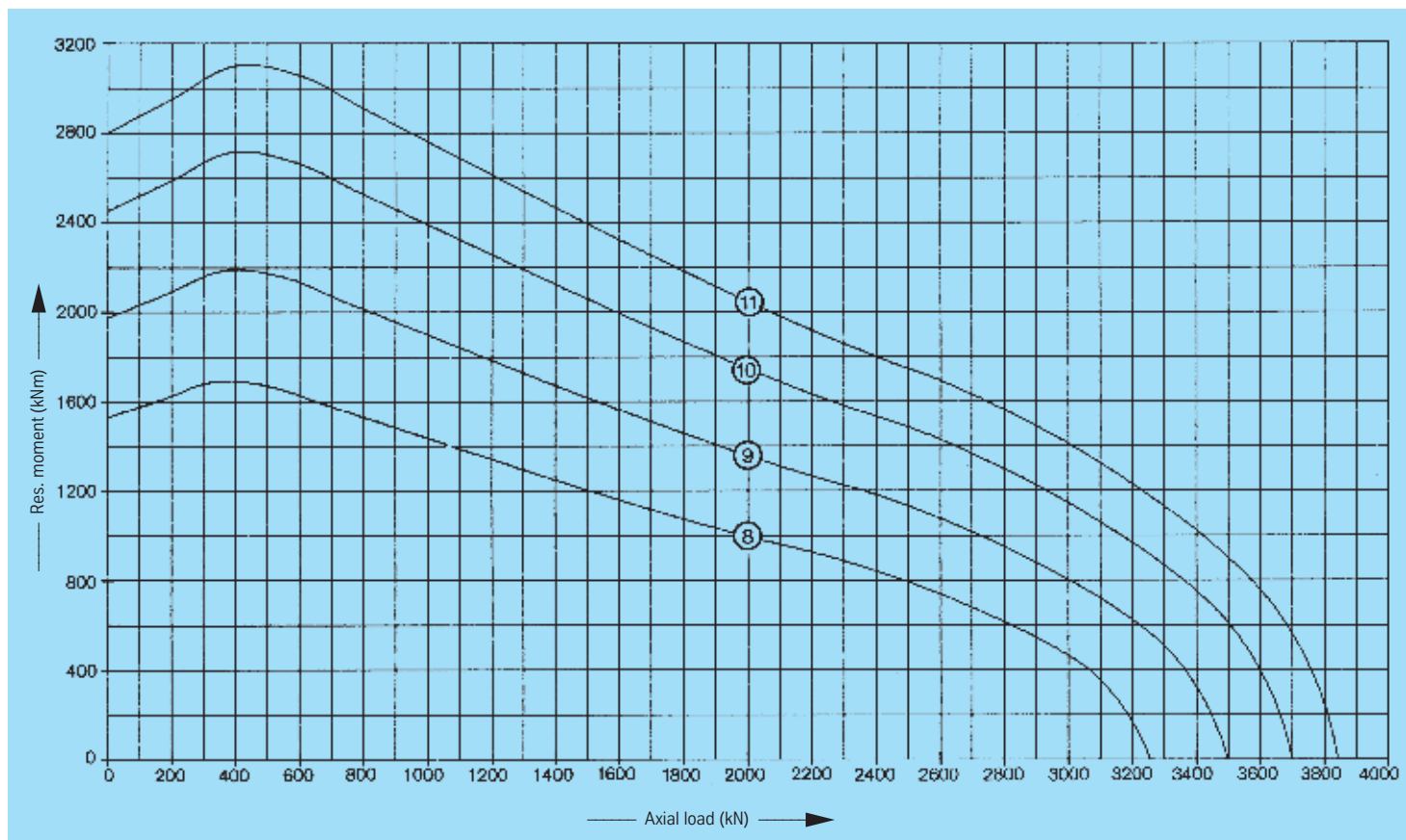

Standard series KD 320



Rothe Erde
Slew Bearings

Bearings with external gear

Drawing No. Ball track dia. D_L [mm]	Weight [kg]	Outer diameter (O.D.) D_o [mm]	Inner diameter (I.D.) D_i [mm]	Overall height H [mm]	External bolt circle dia. L_e [mm]	Internal bolt circle dia. L_i [mm]	Number of bolt holes per hole circle n	Bolt hole diameter B [mm]	Bolt size M [mm]	Number of grease nipples per level n_1	Diameter O [mm]	Diameter U [mm]	Ring height H_1 [mm]	Ring height H_2 [mm]	Distance at bottom Outer ring/inner ring H_b [mm]	Distance at top Outer ring/inner ring H_o [mm]	Gear P.C.D. d [mm]	Module m [mm]	Number of teeth z	Addendum modification sign per DIN 3960 October, 1976 $x \cdot m$ [mm]	Addendum reduction $k \cdot m$ [mm]	Tooth width b [mm]	Permissible tangential forces, normal [kN]	Permissible tangential forces, maximum [kN]	Curves
011.35.1750.700.11.1503 011.35.1750.701.41.1503	789	1985,2	1620	138	1860	1670	44	26	24	3	1784	1779	104	132	6	34	1946	14	139	+7,0	-1,4	104	91,4	182,8	(12)
011.35.2220.000.11.1503 011.35.2220.001.41.1503	1019	2461,2	2090	138	2335	2135	60	26	24	4	2254	2249	104	132	6	34	2422	14	173	+7,0	-1,4	104	91,4	182,8	(13)
011.35.2620.000.11.1503 011.35.2620.001.41.1503	1244	2876,8	2490	138	2735	2540	60	26	24	6	2654	2649	104	132	6	34	2832	16	177	+8,0	-1,6	104	104,5	209,0	(14)

Gear normalized

Gear quenched and tempered

Static limiting load curves

—— Raceway - - - Bolts

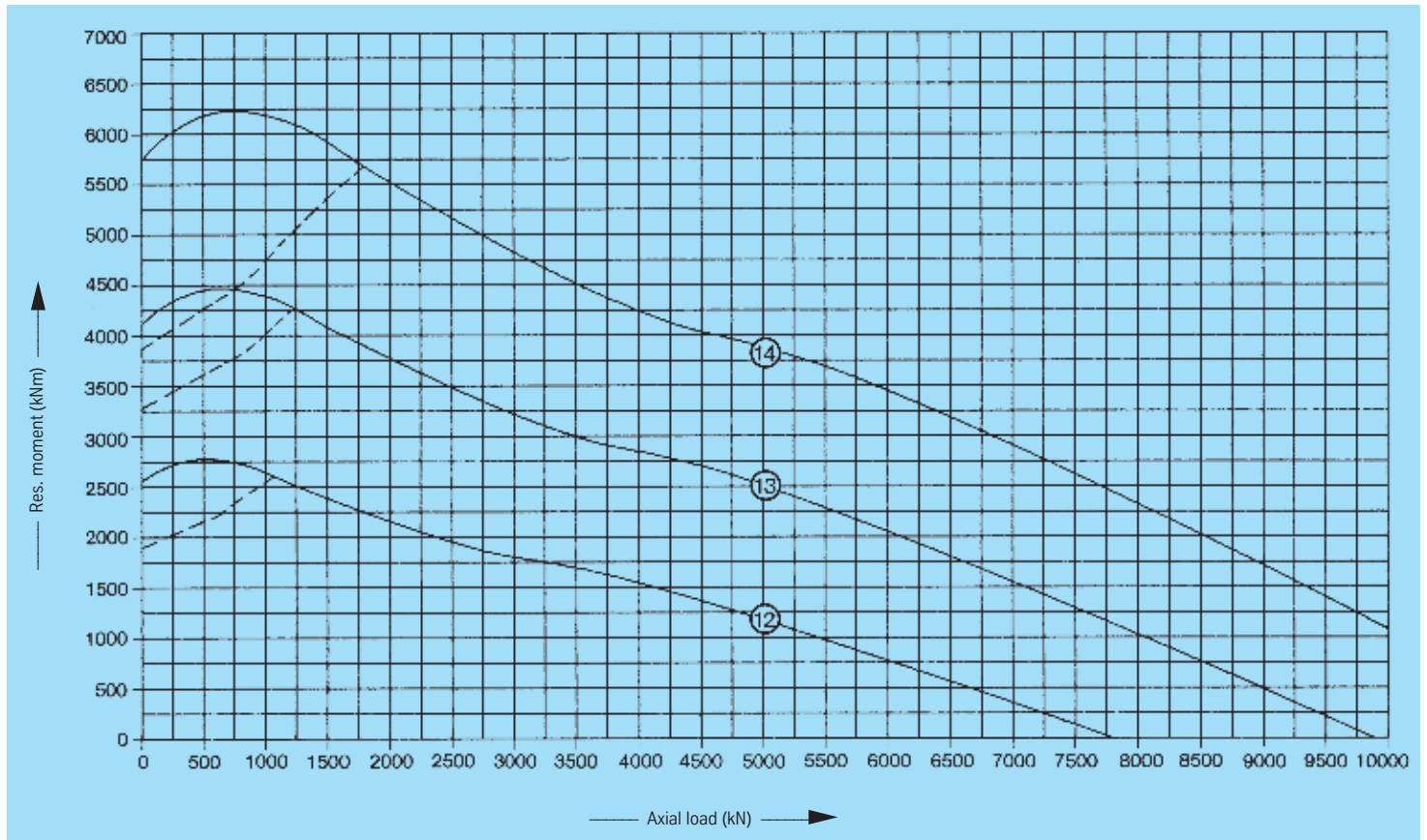

Standard series KD 320



Rothe Erde
Slewing Bearings

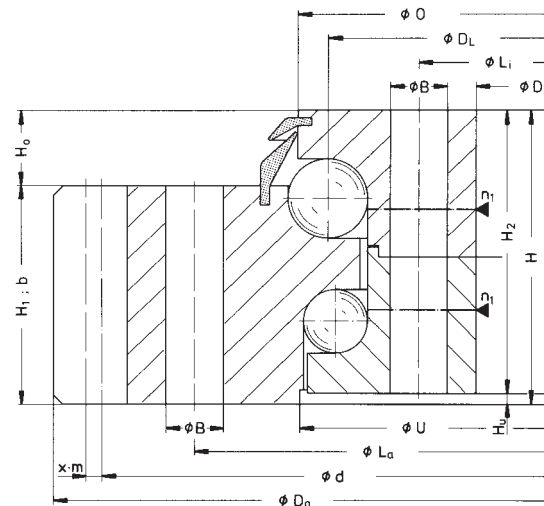

Service life curves · 30,000 revolutions

drawing position = mounting position

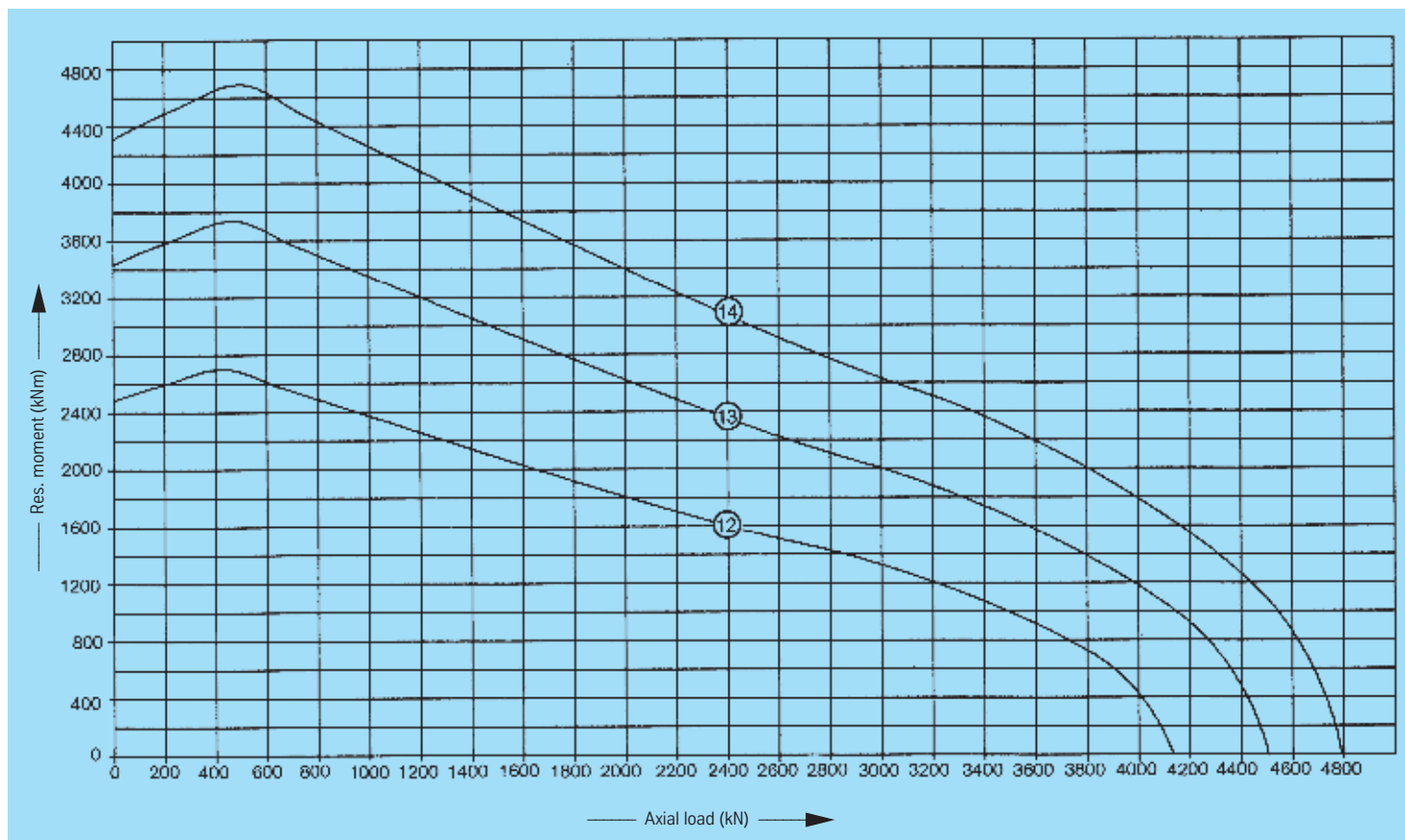

Standard series KD 320



Rothe Erde
Slew Bearings

Bearings with external gear

Drawing No. Ball track dia. D_L [mm]	Weight [kg]	Outer diameter (O.D.) D_o [mm]	Inner diameter (I.D.) D_i [mm]	Overall height H [mm]	External bolt circle dia. L_e [mm]	Internal bolt circle dia. L_i [mm]	Number of bolt holes per hole circle n	Bolt hole diameter B [mm]	Bolt size M [mm]	Number of grease nipples per level n_1	Diameter O [mm]	Diameter U [mm]	Ring height H_1 [mm]	Ring height H_2 [mm]	Distance at bottom Outer ring/inner ring H_b [mm]	Distance at top Outer ring/inner ring H_o [mm]	Gear P.C.D. d [mm]	Module m [mm]	Number of teeth z	Addendum modification sign per DIN 3960 October, 1976 $x \cdot m$ [mm]	Addendum reduction $k \cdot m$ [mm]	Tooth width b [mm]	Permissible tangential forces, normal [kN]	Permissible tangential forces, maximum [kN]	Curves
011.40.2240.000.11.1502 011.40.2240.001.41.1502	1316	2524,8	2090	156	2375	2145	48	33	30	4	2272	2275	117	150	6	39	2480	16	155	+ 8	-1,6	117	117,5 162,7	235,1 325,5	15
011.40.2619.000.11.1502 011.40.2619.001.41.1502	1615	2912,4	2465	156	2755	2520	52	33	30	6	2651	2654	117	150	6	39	2862	18	159	+ 9	-1,8	117	132,2 183,1	264,5 366,2	16
011.40.2795.000.11.1502 011.40.2795.001.41.1502	1723	3096,0	2645	156	2930	2700	54	33	30	6	2827	2830	117	150	6	39	3040	20	152	+10	-2,0	117	146,9 203,4	293,9 406,8	17
011.40.2915.000.11.1502 011.40.2915.001.41.1502	1790	3216,0	2765	156	3050	2820	60	33	30	6	2947	2950	117	150	6	39	3160	20	158	+10	-2,0	117	146,9 203,4	293,9 406,8	18
011.40.3150.000.11.1502 011.40.3150.001.41.1502	1969	3456,0	3000	156	3285	3055	60	33	30	6	3182	3185	117	150	6	39	3400	20	170	+10	-2,0	117	146,9 203,4	293,9 406,8	19

Gear normalized
Gear quenched and tempered

Static limiting load curves

—— Raceway - - - Bolts

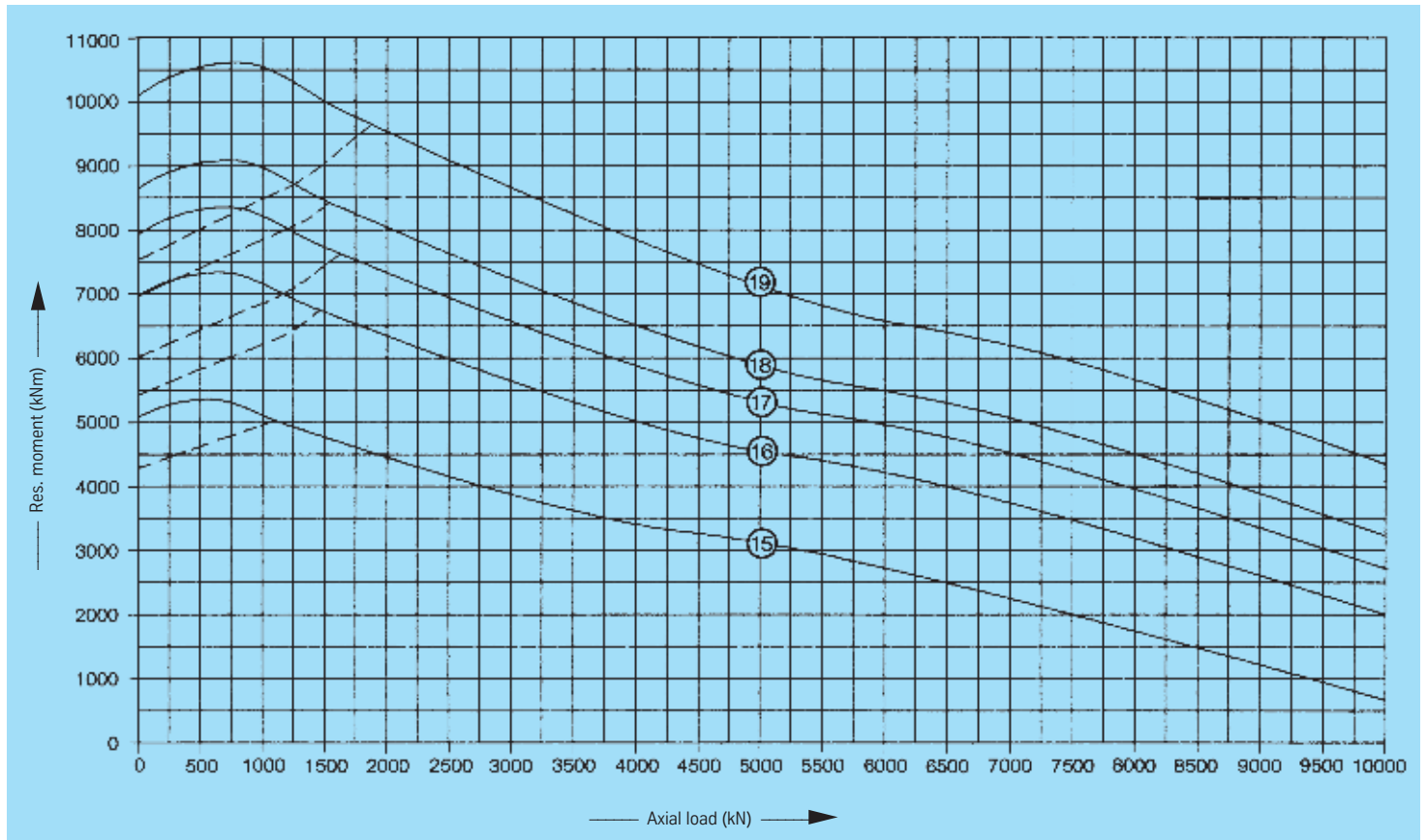

Standard series KD 320



Rothe Erde
Slewing Bearings

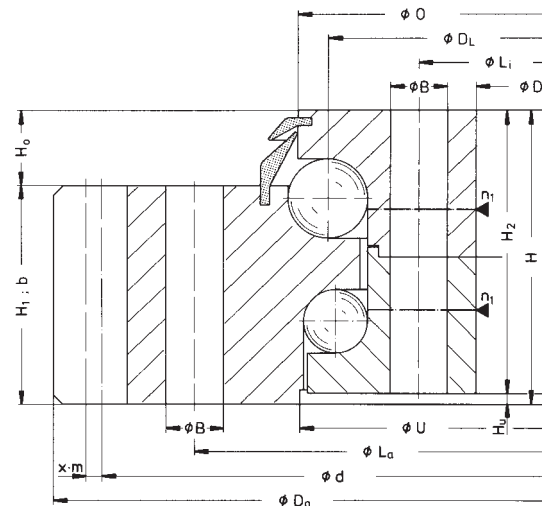

Service life curves · 30,000 revolutions

drawing position = mounting position

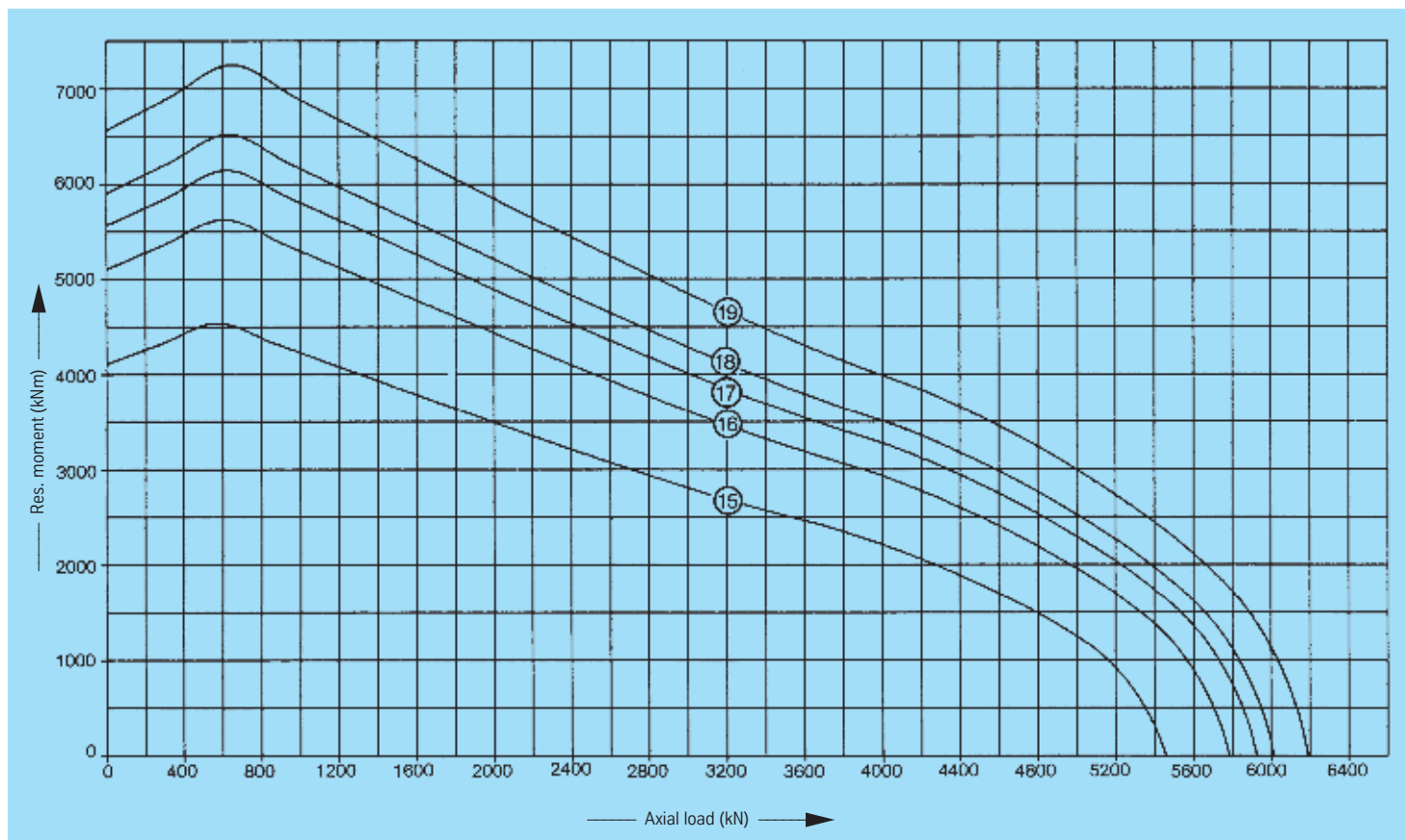

Standard series KD 320



Rothe Erde
Slewing Bearings

Bearings with external gear

Drawing No. Ball track dia. D_L [mm]	Weight [kg]	Outer diameter (O.D.) D_o [mm]	Inner diameter (I.D.) D_i [mm]	Overall height H [mm]	External bolt circle dia. L_e [mm]	Internal bolt circle dia. L_i [mm]	Number of bolt holes per hole circle n	Bolt hole diameter B [mm]	Bolt size M [mm]	Number of grease nipples per level n_1	Diameter O [mm]	Diameter U [mm]	Ring height H_1 [mm]	Ring height H_2 [mm]	Distance at bottom Outer ring/inner ring H_b [mm]	Distance at top Outer ring/inner ring H_o [mm]	Gear P.C.D. d [mm]	Module m [mm]	Number of teeth z	Addendum modification sign per DIN 3960 October, 1976 $x \cdot m$ [mm]	Addendum reduction $k \cdot m$ [mm]	Tooth width b [mm]	Permissible tangential forces, normal [kN]	Permissible tangential forces, maximum [kN]	Curves
011.50.2987.001.49.1502	2288	3290,4	2820	185	3130	2880	66	33	30	6	3025	3022	138	178	7	47	3240	18	180	+ 9	-1,8	138	216,0	432,0	20
011.50.3167.001.49.1502	2431	3470,4	3000	185	3310	3060	66	33	30	6	3205	3202	138	178	7	47	3420	18	190	+ 9	-1,8	138	216,0	432,0	21
011.50.3347.001.49.1502	2566	3650,4	3180	185	3490	3240	72	33	30	6	3385	3382	138	178	7	47	3600	18	200	+ 9	-1,8	138	216,0	432,0	22
011.50.3567.001.49.1502	2702	3866,4	3400	185	3710	3460	78	33	30	6	3605	3602	138	178	7	47	3816	18	212	+ 9	-1,8	138	216,0	432,0	23
011.50.3747.001.49.1502	2837	4046,4	3580	185	3890	3640	84	33	30	6	3785	3782	138	178	7	47	3996	18	222	+ 9	-1,8	138	216,0	432,0	24
011.50.4140.001.49.1502	3282	4456,0	3970	187	4285	4030	90	33	30	6	4178	4175	140	178	9	47	4400	20	220	+10	-2,0	140	243,4	486,9	25

Gear quenched and tempered

Static limiting load curves

—— Raceway - - - Bolts

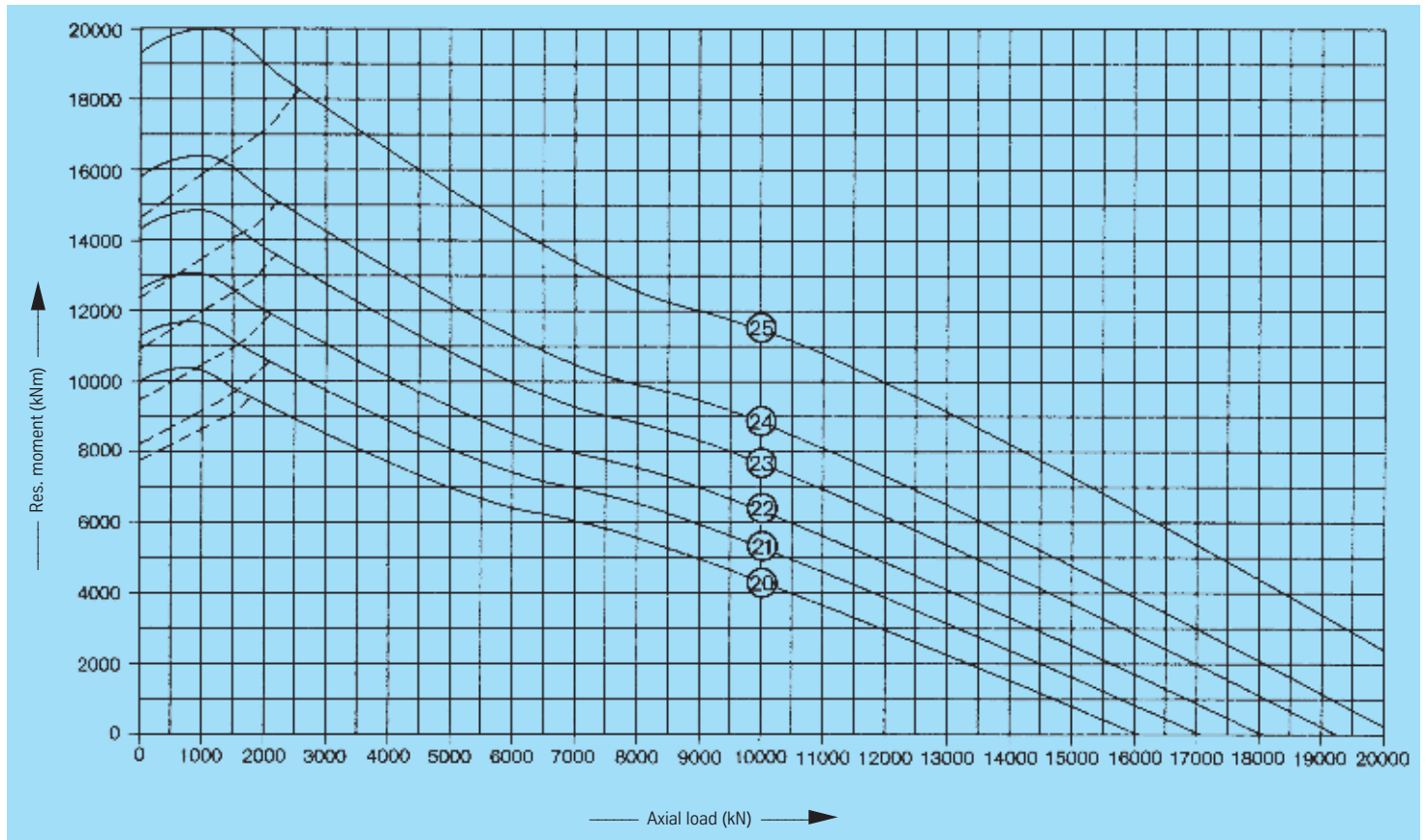

Standard series KD 320



Rothe Erde
Slewing Bearings

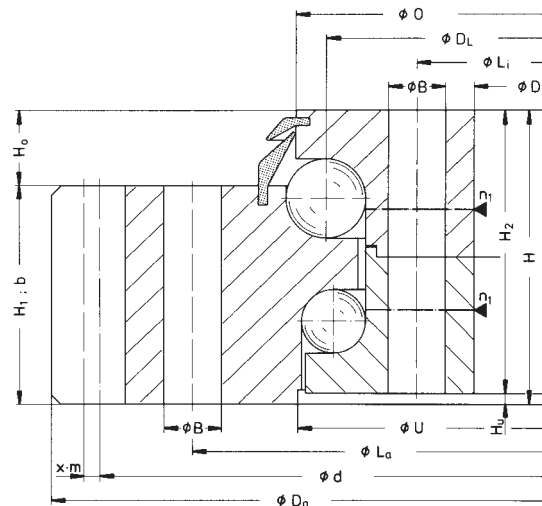

Service life curves · 30,000 revolutions

drawing position = mounting position

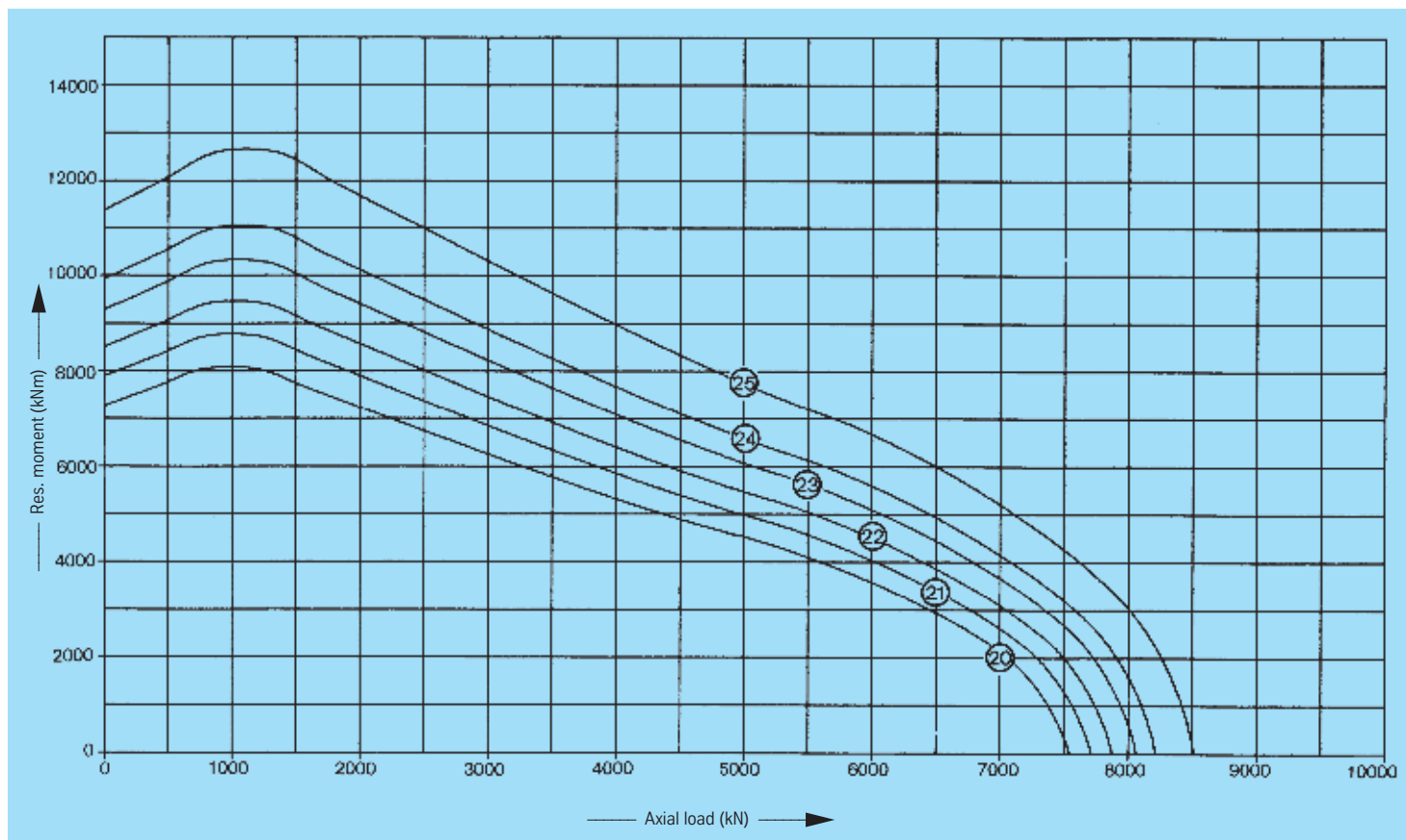

Standard series KD 320



Rothe Erde
Slewing Bearings

Bearings with internal gear

Drawing No. Ball track dia. D_t [mm]	Weight [kg]	Outer diameter (O.D.) D_o [mm]	Inner diameter (I.D.) D_i [mm]	Overall height H [mm]	External bolt circle dia. L_e [mm]	Internal bolt circle dia. L_i [mm]	Number of bolt holes per hole circle n	Bolt hole diameter B [mm]	Bolt size M [mm]	Number of grease nipples per level n_1	Diameter O [mm]	Diameter U [mm]	Ring height H_1 [mm]	Ring height H_2 [mm]	Distance at bottom Outer ring/inner ring H_b [mm]	Distance at top Outer ring/inner ring H_o [mm]	Gear P.C.D. d [mm]	Module m [mm]	Number of teeth z	Addendum modification sign per DIN 3960 October, 1976 $x \cdot m$ [mm]	Addendum reduction $k \cdot m$ [mm]	Tooth width b [mm]	Permissible tangential forces, normal [kN]	Permissible tangential forces, maximum [kN]	Curves
012.18.0748.000.11.1504 012.18.0748.002.21.1504	90	823	648	77	798	705	24	17,5	16	4	710	734	54	74	3	23	660	6	110	-0,0	-	45	15,20 23,25	30,40 46,50	②6
012.20.0895.000.11.1504 012.20.0895.001.21.1504	118	971	784	82	944	850	30	17,5	16	2	854	879	58	78	4	24	800	8	100	-0,0	-	50	22,60 34,75	45,20 69,50	②7
012.20.1085.000.11.1504 012.20.1085.001.21.1504	154	1161	960	90	1134	1040	36	17,5	16	2	1044	1069	66	78	12	24	980	10	98	-0,0	-	55	31,10 48,00	62,20 96,00	②8
012.20.1360.000.11.1504 012.20.1360.001.21.1504	213	1440	1210	82	1410	1300	54	17,5	16	3	1319	1342	58	78	4	24	1220	10	122	-5,0	-	58	36,40 56,00	72,80 112,00	②9

Gear normalized

Gear quenched and tempered

Static limiting load curves

—— Raceway - - - Bolts

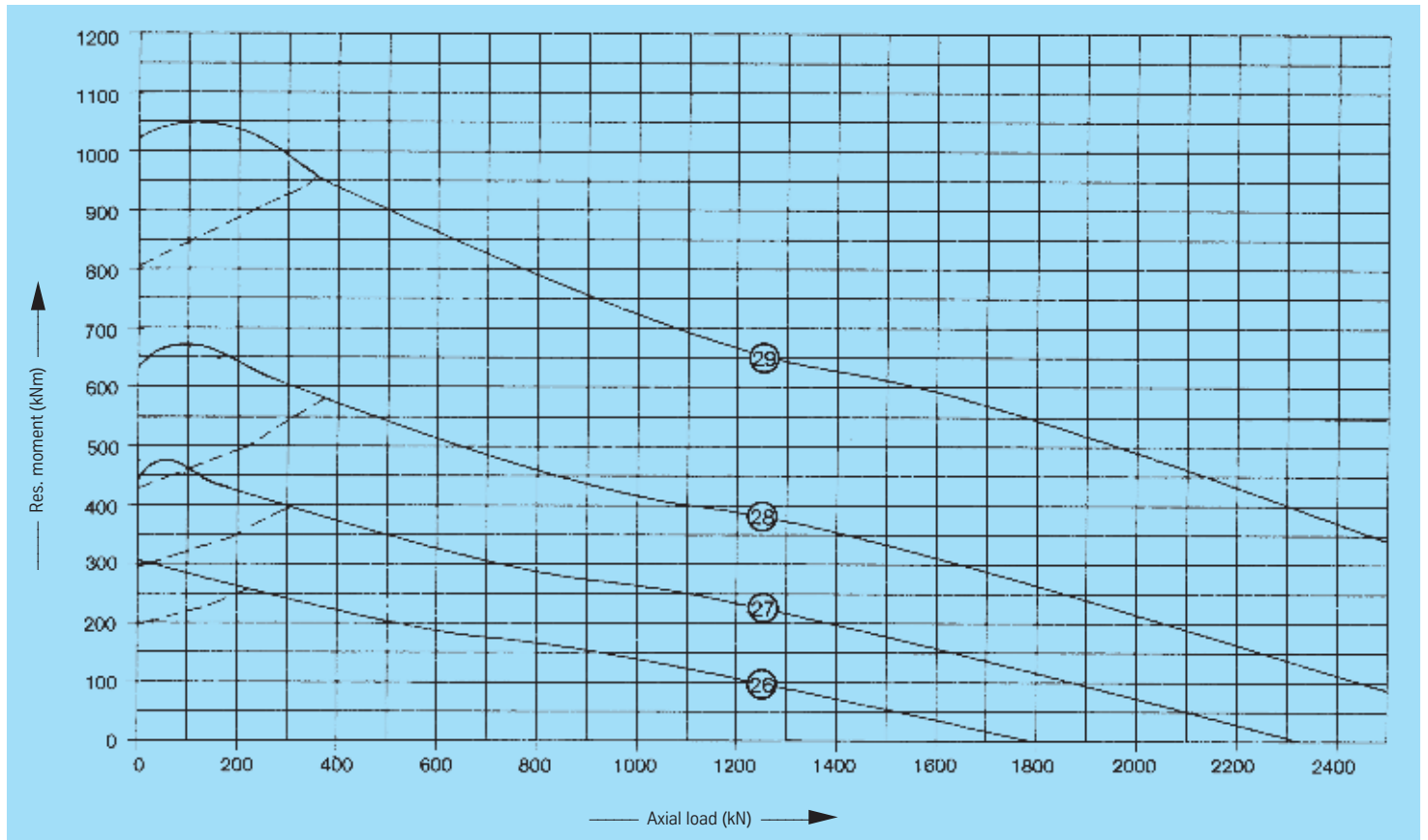

Standard series KD 320



Rothe Erde
Slewing Bearings

Thread depth t [mm]	Tooth neck dia. Z_u [mm]	Tooth neck height h_u [mm]	Curves
30	678	9	(26)
35	820	8	(27)
35	1010	11	(28)
35	-	-	(29)

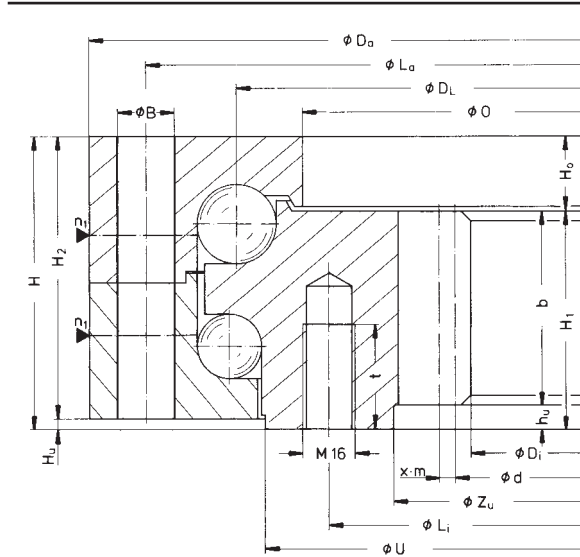

Drawing number **012.18.0748.000.11.1504**
012.18.0748.002.21.1504

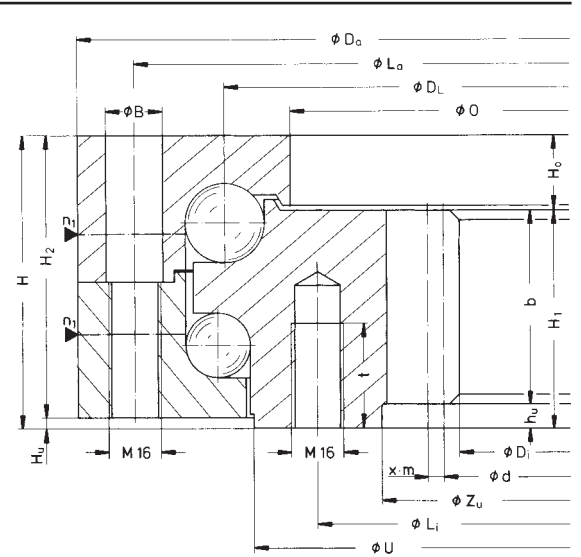

Drawing number **012.20.0895.000.11.1504**
012.20.0895.001.21.1504
012.20.1085.000.11.1504
012.20.1085.001.21.1504
012.20.1360.000.11.1504
012.20.1360.001.21.1504

Service life curves · 30,000 revolutions

drawing position = mounting position

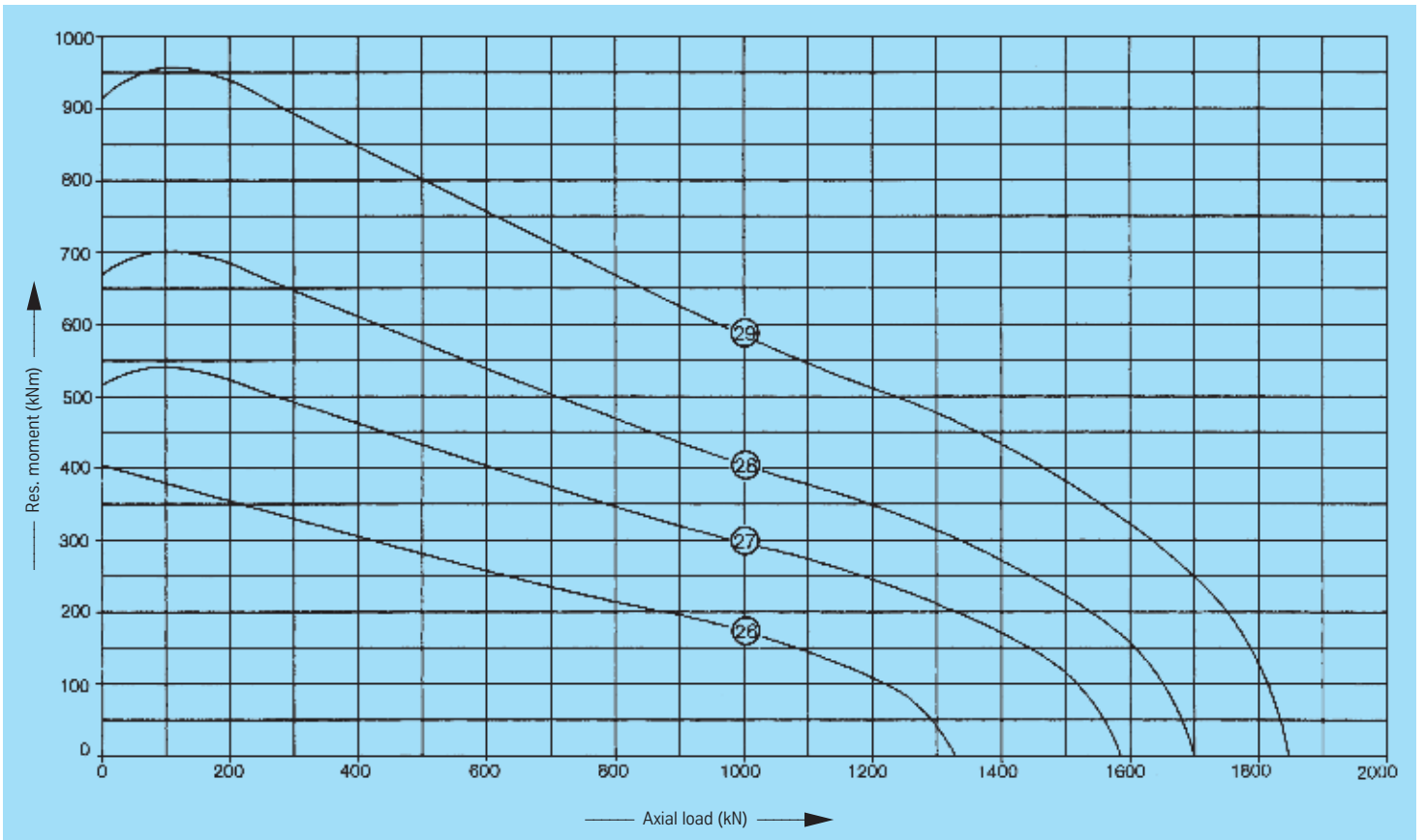

Standard series KD 320



Rothe Erde
Slewing Bearings

Bearings with internal gear

Drawing No. Ball track dia. D_L [mm]	Weight [kg]	Outer diameter (O.D.) D_o [mm]	Inner diameter (I.D.) D_i [mm]	Overall height H [mm]	External bolt circle dia. L_e [mm]	Internal bolt circle dia. L_i [mm]	Number of bolt holes per hole circle n	Bolt hole diameter B [mm]	Bolt size M [mm]	Number of grease nipples per level n_1	Diameter O [mm]	Diameter U [mm]	Ring height H_1 [mm]	Ring height H_2 [mm]	Distance at bottom Outer ring/inner ring H_b [mm]	Distance at top Outer ring/inner ring H_o [mm]	Gear P.C.D. d [mm]	Module m [mm]	Number of teeth z	Addendum modification sign per DIN 3960 October, 1976 $x \cdot m$ [mm]	Addendum reduction $k \cdot m$ [mm]	Tooth width b [mm]	Permissible tangential forces, normal [kN]	Permissible tangential forces, maximum [kN]	Curves
012.25.1360.600.11.1503 012.25.1360.601.21.1503	336	1460	1180	102	1425	1270	36	22	20	3	1337	1342	76	96	6	26	1190	10	119	-5,0	-	76	47,70 69,75	95,40 139,50	30
012.25.1600.000.11.1503 012.25.1600.001.21.1503	405	1700	1404	102	1665	1510	42	22	20	3	1577	1582	76	96	6	26	1416	12	118	-6,0	-	76	57,20 83,70	114,40 167,40	31

Gear normalized

Gear quenched and tempered

Static limiting load curves

—— Raceway

- - - Bolts

—— Bolts

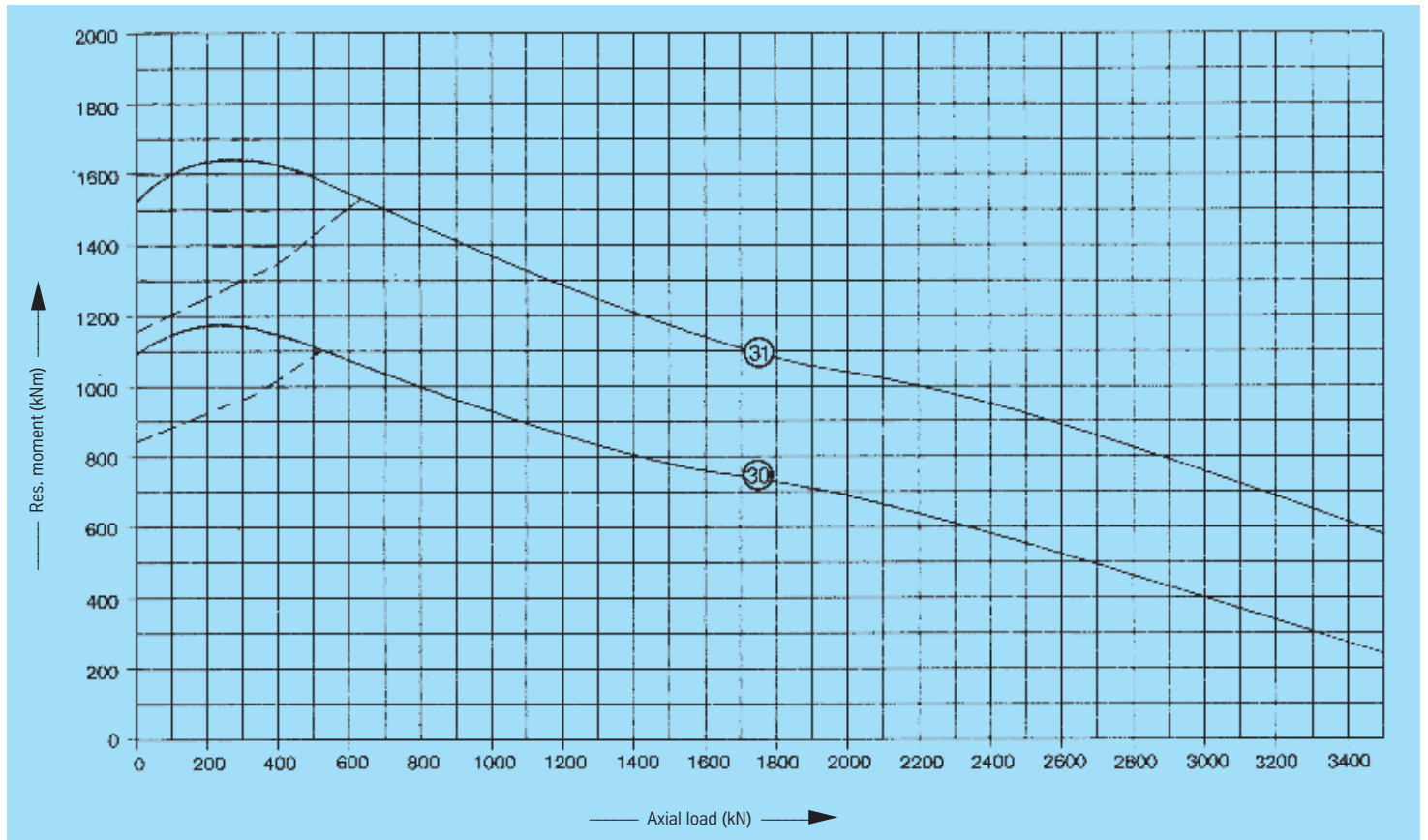

Standard series KD 320



Rothe Erde
Slewing Bearings

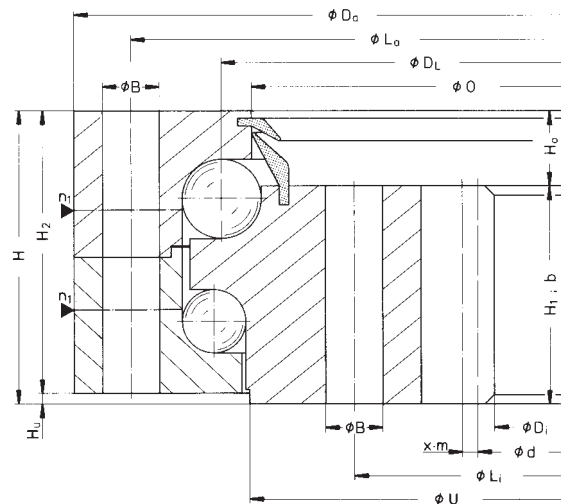

Service life curves · 30,000 revolutions

drawing position = mounting position

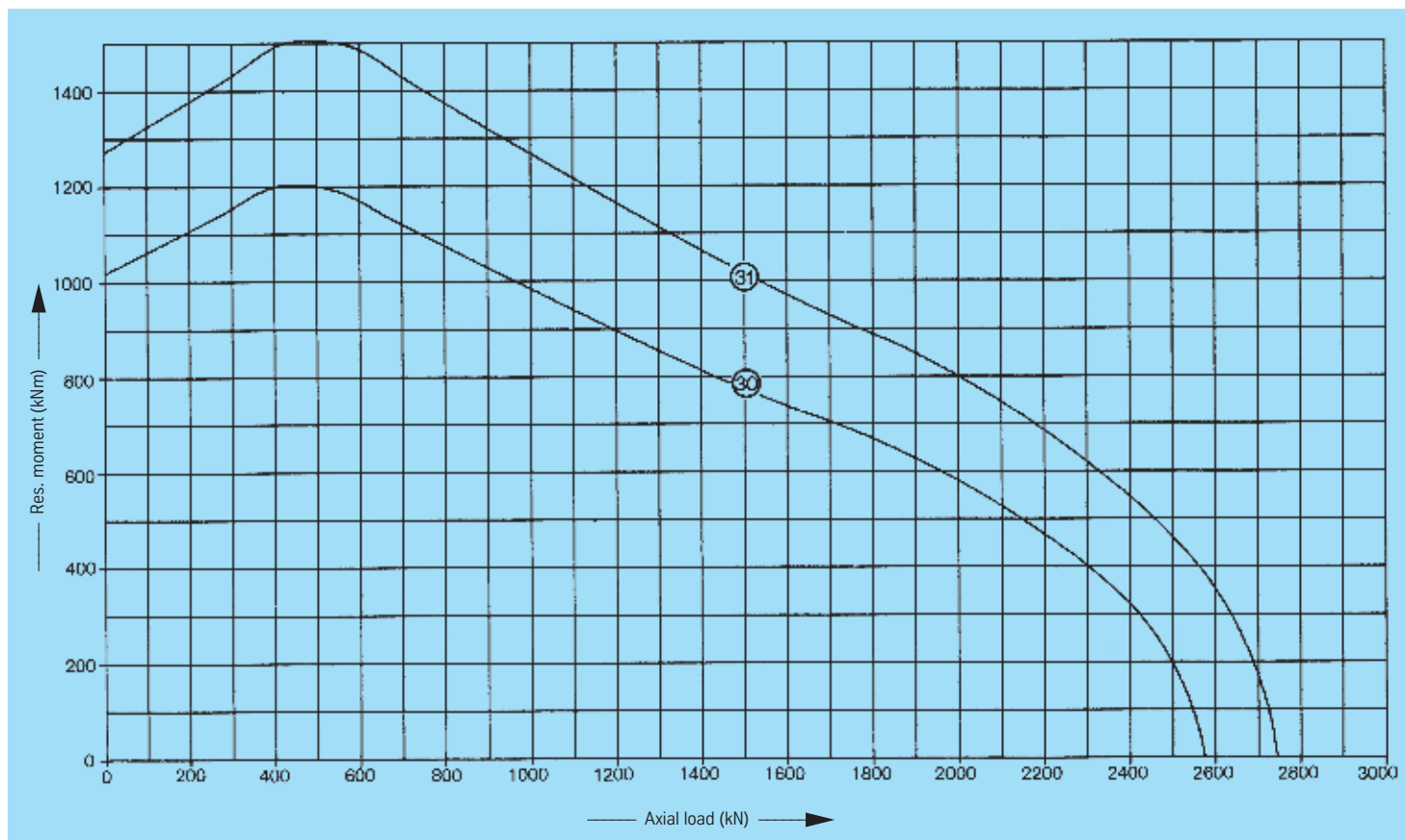

Standard series KD 320



Rothe Erde
Slewing Bearings

Bearings with internal gear

Drawing No. Ball track dia. D_t [mm]	Weight [kg]	Outer diameter (O.D.) D_o [mm]	Inner diameter (I.D.) D_i [mm]	Overall height H [mm]	External bolt circle dia. L_e [mm]	Internal bolt circle dia. L_i [mm]	Number of bolt holes per hole circle n	Bolt hole diameter B [mm]	Bolt size M [mm]	Number of grease nipples per level n_1	Diameter O [mm]	Diameter U [mm]	Ring height H_1 [mm]	Ring height H_2 [mm]	Distance at bottom Outer ring/inner ring H_b [mm]	Distance at top Outer ring/inner ring H_o [mm]	Gear P.C.D. d [mm]	Module m [mm]	Number of teeth z	Addendum modification sign per DIN 3960 October, 1976 $x \cdot m$ [mm]	Addendum reduction $k \cdot m$ [mm]	Tooth width b [mm]	Permissible tangential forces, normal [kN]	Permissible tangential forces, maximum [kN]	Curves
012.30.1381.000.11.1503 012.30.1381.001.41.1503	474	1500	1164	120	1455	1275	36	26	24	3	1352	1358	91	114	6	29	1176	12	98	-6,0	-	91	68,5 100,2	137,0 200,4	32
012.30.1630.000.11.1503 012.30.1630.001.41.1503	558	1750	1416	120	1705	1525	40	26	24	4	1602	1610	91	114	6	29	1428	12	119	-6,0	-	91	68,5 100,2	137,0 200,4	33
012.30.1800.000.11.1503 012.30.1800.001.41.1503	645	1920	1568	120	1875	1695	48	26	24	3	1771	1777	91	114	6	29	1582	14	113	-7,0	-	91	80,0 116,9	160,0 233,8	34
012.30.1995.000.11.1503 012.30.1995.001.41.1503	716	2115	1764	120	2070	1890	48	26	24	4	1966	1972	91	114	6	29	1778	14	127	-7,0	-	91	80,0 116,9	160,0 233,8	35
012.30.2330.000.11.1503 012.30.2330.001.41.1503	839	2450	2100	120	2405	2225	54	26	24	4	2301	2307	91	114	6	29	2114	14	151	-7,0	-	91	80,0 116,9	160,0 233,8	36
012.30.2538.000.11.1503 012.30.2538.001.41.1503	963	2660	2288	120	2615	2430	60	26	24	6	2509	2515	91	114	6	29	2304	16	144	-8,0	-	91	91,4 133,6	182,8 267,2	37

Gear normalized
Gear quenched and tempered

Static limiting load curves

—— Raceway - - - Bolts

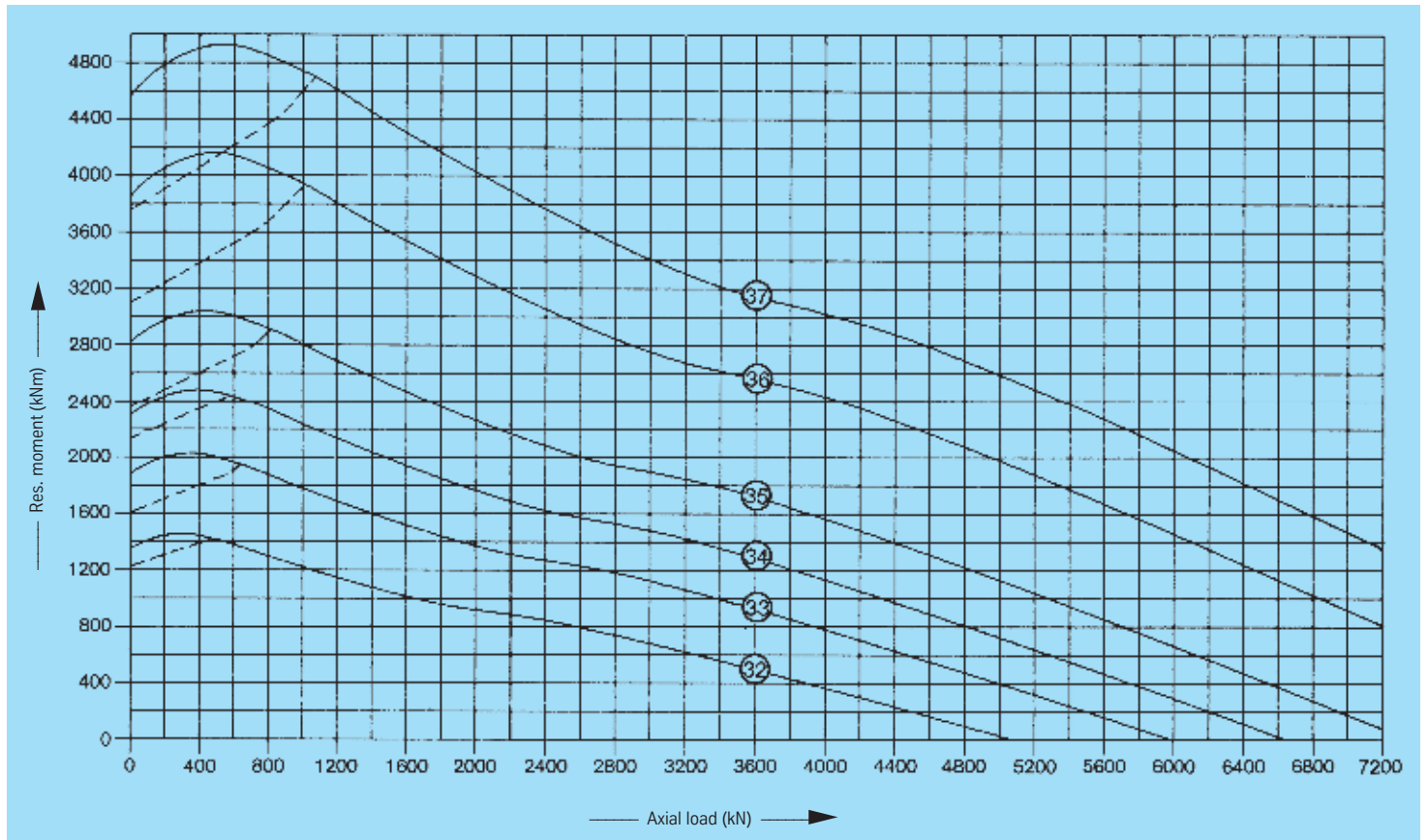

Standard series KD 320



Rothe Erde
Slewing Bearings

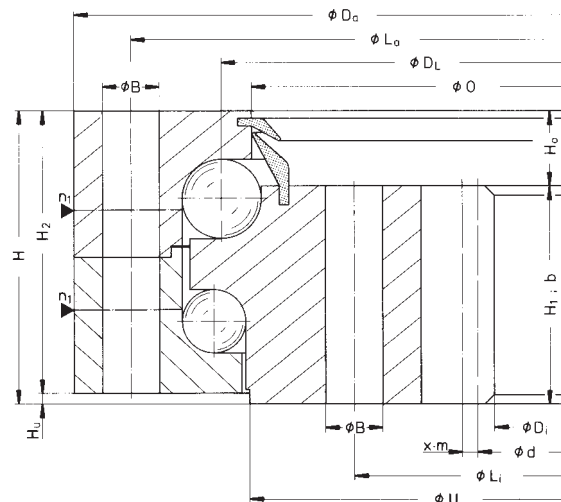

Service life curves · 30,000 revolutions

drawing position = mounting position

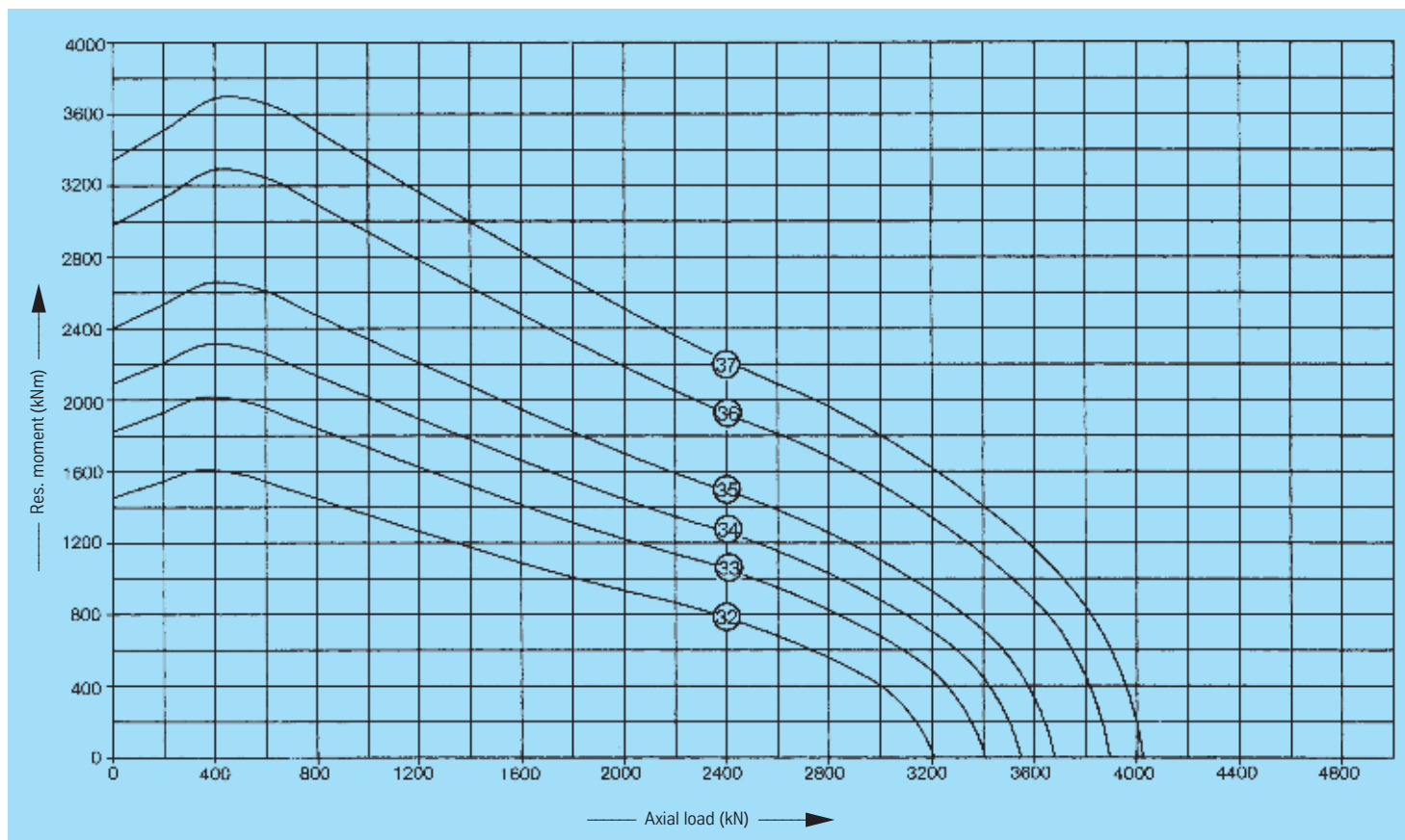

Standard series KD 320



Rothe Erde
Slewing Bearings

Bearings with internal gear

Drawing No. Ball track dia. D_L [mm]	Weight [kg]	Outer diameter (O.D.) D_o [mm]	Inner diameter (I.D.) D_i [mm]	Overall height H [mm]	External bolt circle dia. L_e [mm]	Internal bolt circle dia. L_i [mm]	Number of bolt holes per hole circle n	Bolt hole diameter B [mm]	Bolt size M [mm]	Number of grease nipples per level n_1	Diameter O [mm]	Diameter U [mm]	Ring height H_1 [mm]	Ring height H_2 [mm]	Distance at bottom Outer ring/inner ring H_b [mm]	Distance at top Outer ring/inner ring H_o [mm]	Gear P.C.D. d [mm]	Module m [mm]	Number of teeth z	Addendum modification sign per DIN 3960 October, 1976 $x \cdot m$ [mm]	Addendum reduction $k \cdot m$ [mm]	Tooth width b [mm]	Permissible tangential forces, normal [kN]	Permissible tangential forces, maximum [kN]	Curves
012.35.1960.400.11.1503 012.35.1960.401.41.1503	851	2090	1722	138	2045	1850	52	26	24	4	1926	1931	104	132	6	34	1736	14	124	-7,0	-	104	91,4 133,6	182,8 267,2	38
012.35.2500.000.11.1503 012.35.2500.001.41.1503	1112	2630	2254	138	2585	2385	66	26	24	6	2466	2471	104	132	6	34	2268	14	162	-7,0	-	104	91,4 133,6	182,8 267,2	39
012.35.2690.000.11.1503 012.35.2690.001.41.1503	1225	2820	2432	138	2775	2580	72	26	24	6	2656	2661	104	132	6	34	2448	16	153	-8,0	-	104	104,5 152,7	209,0 305,4	40

Gear normalized

Gear quenched and tempered

Static limiting load curves

—— Raceway - - - Bolts

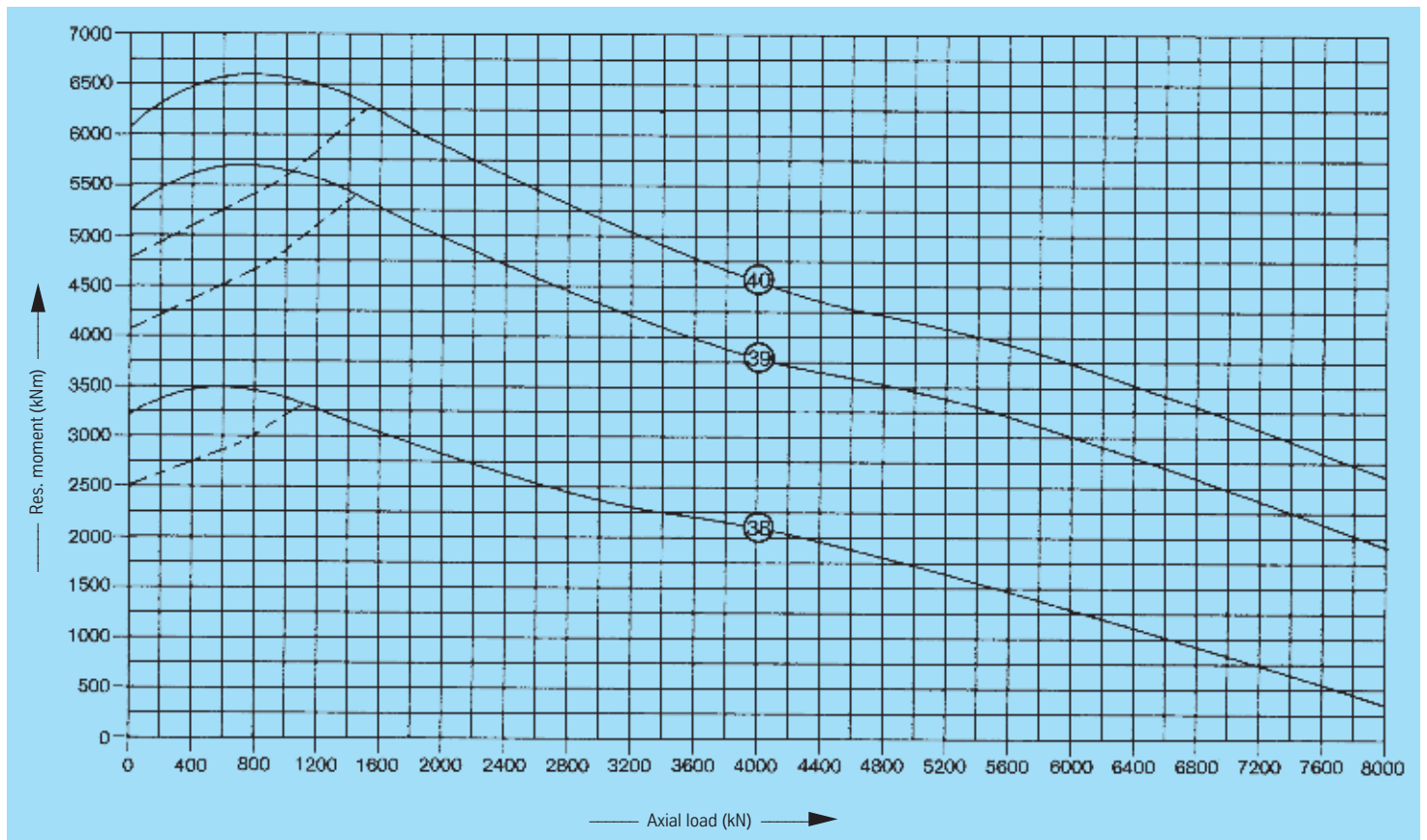

Standard series KD 320



Rothe Erde
Slewing Bearings

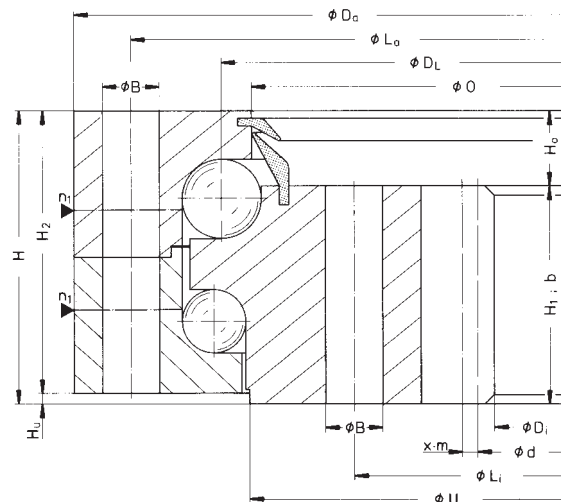

Service life curves · 30,000 revolutions

drawing position = mounting position

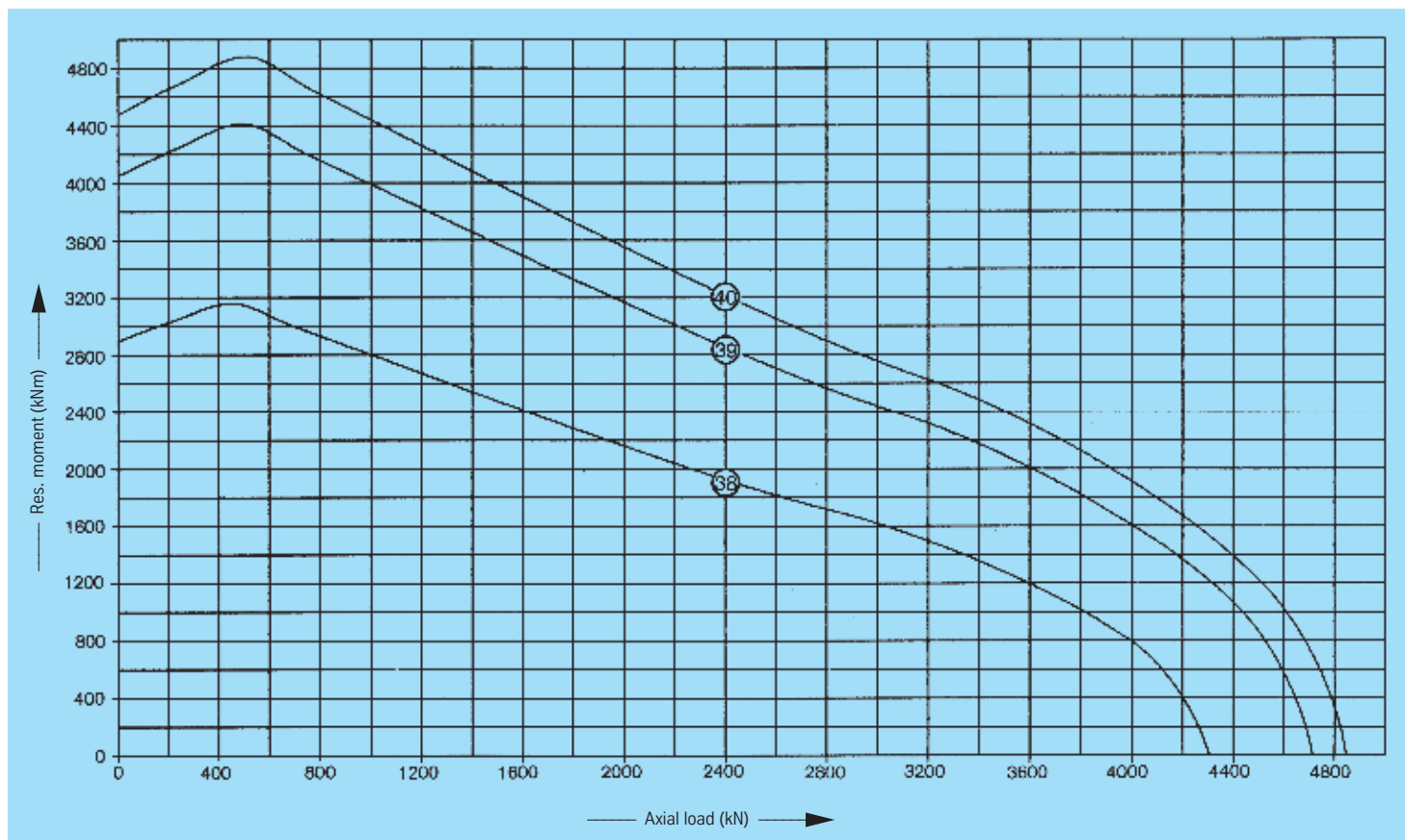

Standard series KD 320



Rothe Erde
Slew Bearings

Bearings with internal gear

Drawing No. Ball track dia. D_L [mm]	Weight [kg]	Outer diameter (O.D.) D_o [mm]	Inner diameter (I.D.) D_i [mm]	Overall height H [mm]	External bolt circle dia. L_e [mm]	Internal bolt circle dia. L_i [mm]	Number of bolt holes per hole circle n	Bolt hole diameter B [mm]	Bolt size M [mm]	Number of grease nipples per level n_1	Diameter O [mm]	Diameter U [mm]	Ring height H_1 [mm]	Ring height H_2 [mm]	Distance at bottom Outer ring/inner ring H_b [mm]	Distance at top Outer ring/inner ring H_o [mm]	Gear P.C.D. d [mm]	Module m [mm]	Number of teeth z	Addendum modification sign per DIN 3960 October, 1976 $x \cdot m$ [mm]	Addendum reduction $k \cdot m$ [mm]	Tooth width b [mm]	Permissible tangential forces, normal [kN]	Permissible tangential forces, maximum [kN]	Curves
012.40.2199.300.11.1502 012.40.2199.301.41.1502	1238	2350	1920	156	2295	2065	52	33	30	4	2168	2164	117	150	6	39	1936	16	121	-8,0	-	117	117,5 162,7	235,0 325,5	(41)
012.40.2622.400.11.1502 012.40.2622.401.41.1502	1495	2770	2336	156	2715	2485	60	33	30	6	2590	2587	117	150	6	39	2352	16	147	-8,0	-	117	117,5 162,7	235,0 325,5	(42)
012.40.2950.000.11.1502 012.40.2950.001.41.1502	1764	3100	2646	156	3045	2815	60	33	30	6	2918	2915	117	150	6	39	2664	18	148	-9,0	-	117	132,2 183,1	264,5 366,2	(43)
012.40.3300.000.11.1502 012.40.3300.001.41.1502	1935	3450	3006	156	3395	3165	66	33	30	6	3268	3265	117	150	6	39	3024	18	168	-9,0	-	117	132,2 183,1	264,5 366,2	(44)

Gear normalized
Gear quenched and tempered

Static limiting load curves

—— Raceway - - - Bolts

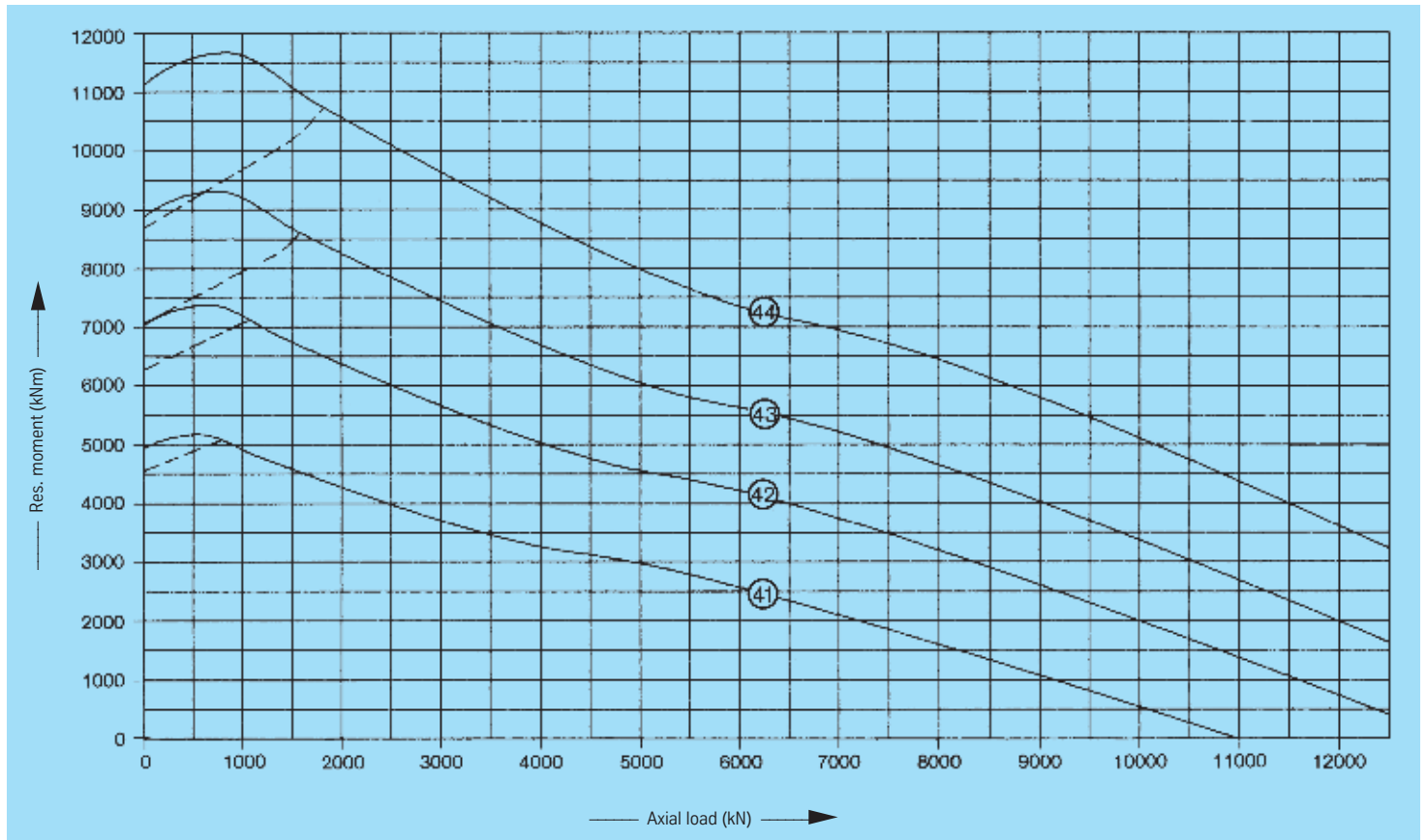

Standard series KD 320



Rothe Erde
Slewing Bearings

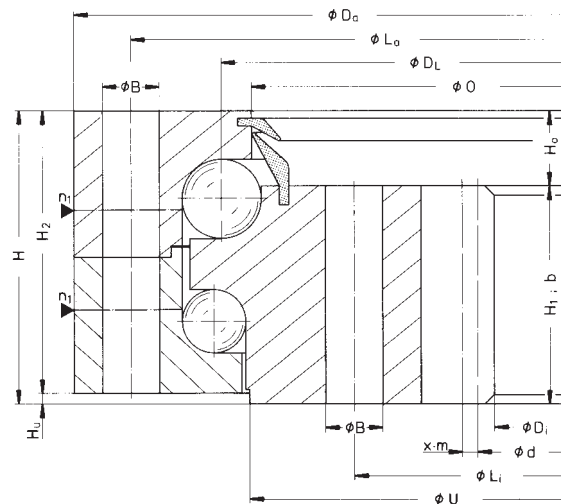

Service life curves · 30,000 revolutions

drawing position = mounting position

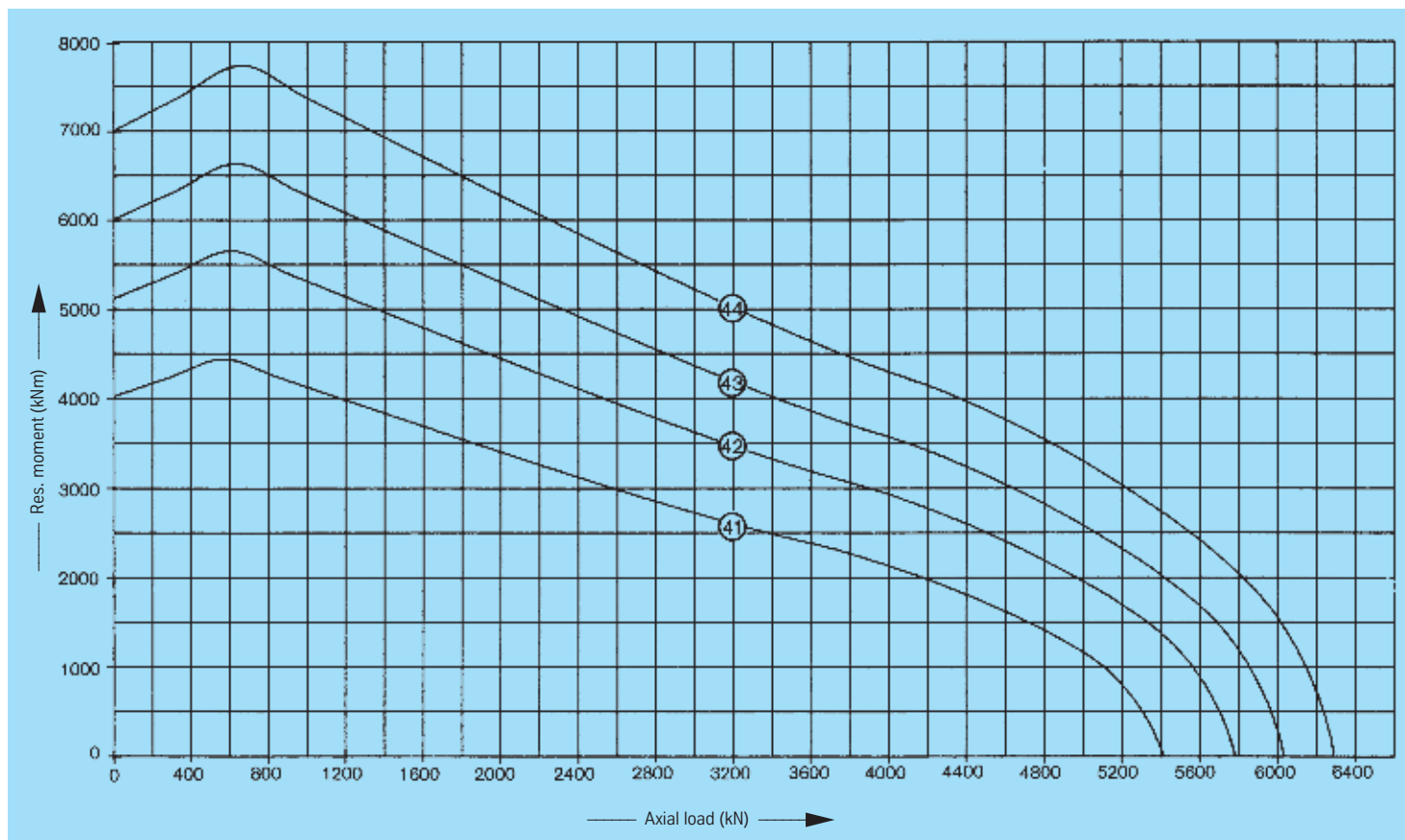

Standard series KD 320



Rothe Erde
Slew Bearings

Bearings with internal gear

Drawing No. Ball track dia. D_L [mm]	Weight [kg]	Outer diameter (O.D.) D_o [mm]	Inner diameter (I.D.) D_i [mm]	Overall height H [mm]	External bolt circle dia. L_e [mm]	Internal bolt circle dia. L_i [mm]	Number of bolt holes per hole circle n	Bolt hole diameter B [mm]	Bolt size M [mm]	Number of grease nipples per level n_1	Diameter O [mm]	Diameter U [mm]	Ring height H_1 [mm]	Ring height H_2 [mm]	Distance at bottom Outer ring/inner ring H_b [mm]	Distance at top Outer ring/inner ring H_o [mm]	Gear P.C.D. d [mm]	Module m [mm]	Number of teeth z	Addendum modification sign per DIN 3960 October, 1976 $x \cdot m$ [mm]	Addendum reduction $k \cdot m$ [mm]	Tooth width b [mm]	Permissible tangential forces, normal [kN]	Permissible tangential forces, maximum [kN]	Curves
012.45.2940.000.19.1502 012.45.2940.001.49.1502	1950	3100	2656	175	3045	2800	66	33	30	6	2903	2900	132	168	7	43	2672	16	167	- 8,0	-	132	132,6	265,2	④5
012.45.3400.100.19.1502 012.45.3400.101.49.1502	2435	3560	3080	175	3505	3260	72	33	30	6	3363	3358	132	168	7	43	3100	20	155	-10,0	-	132	165,8	331,6	④6

Gear normalized

Gear quenched and tempered

Static limiting load curves

—— Raceway - - - Bolts

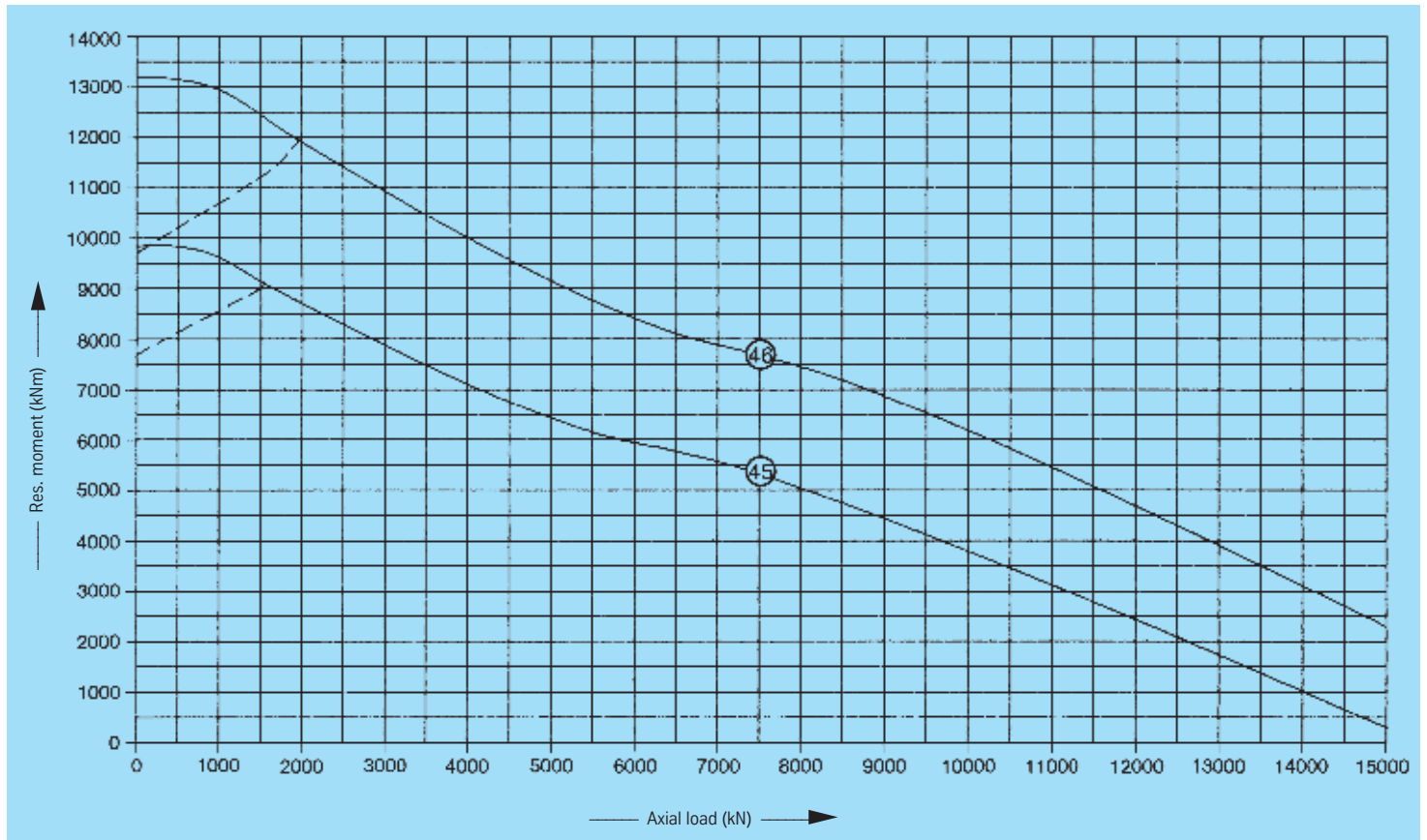

Standard series KD 320



Rothe Erde
Slewing Bearings

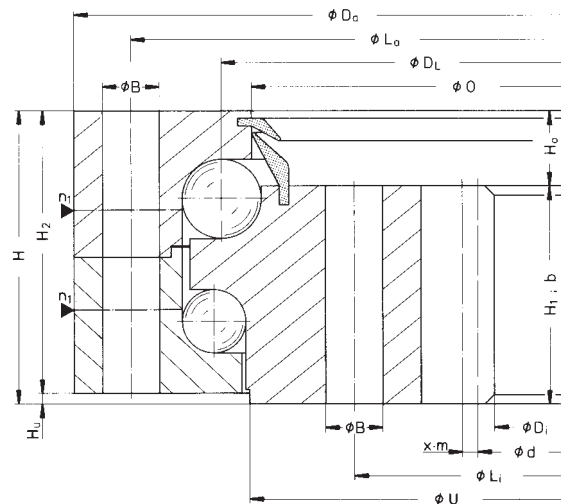

Service life curves · 30,000 revolutions

drawing position = mounting position

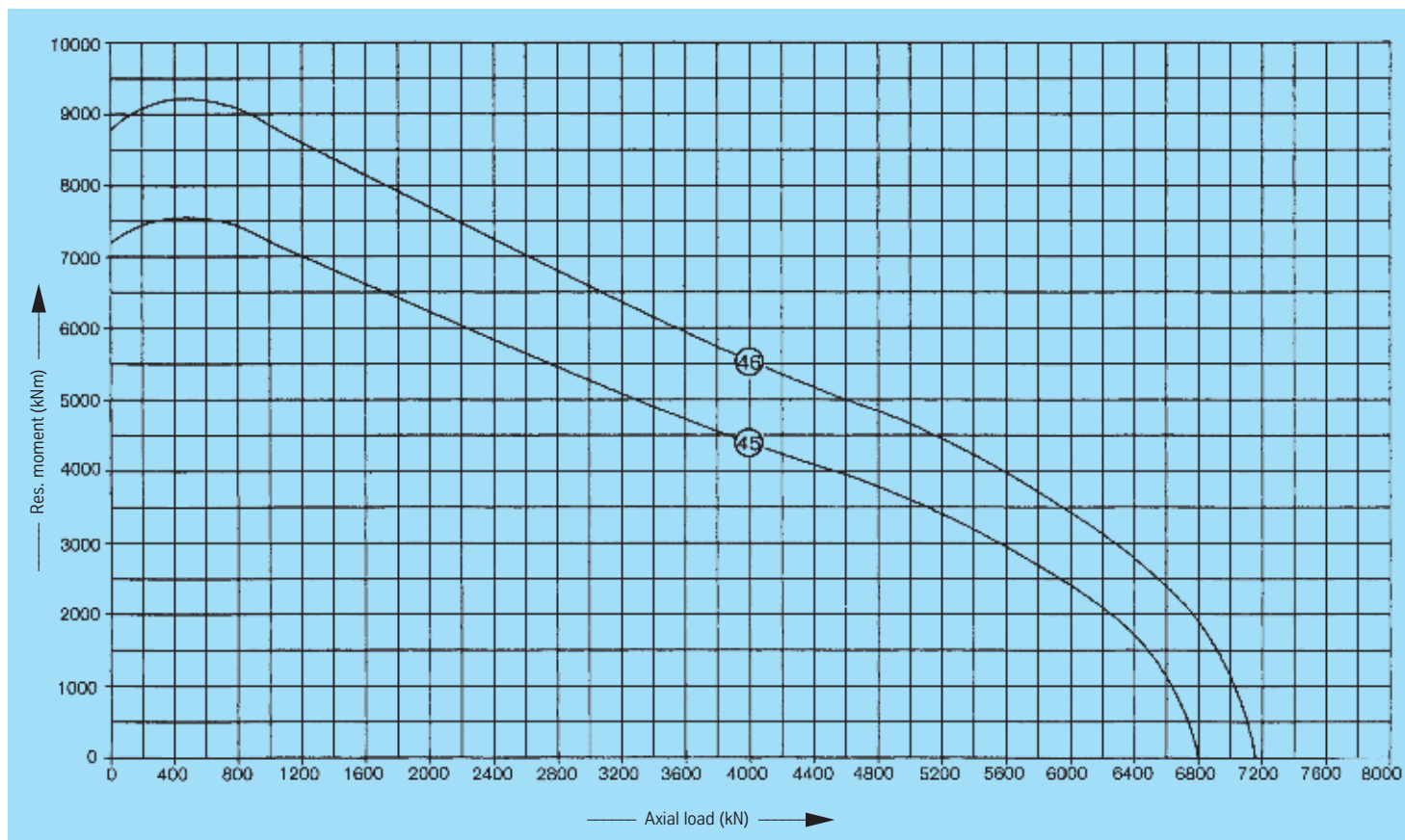

Standard series KD 320



Rothe Erde
Slewing Bearings

Bearings with internal gear

Drawing No. Ball track dia. D_L [mm]	Weight [kg]	Outer diameter (O.D.) D_o [mm]	Inner diameter (I.D.) D_i [mm]	Overall height H [mm]	External bolt circle dia. L_e [mm]	Internal bolt circle dia. L_i [mm]	Number of bolt holes per hole circle n	Bolt hole diameter B [mm]	Bolt size M [mm]	Number of grease nipples per level n_1	Diameter O [mm]	Diameter U [mm]	Ring height H_1 [mm]	Ring height H_2 [mm]	Distance at bottom Outer ring/inner ring H_b [mm]	Distance at top Outer ring/inner ring H_o [mm]	Gear P.C.D. d [mm]	Module m [mm]	Number of teeth z	Addendum modification sign per DIN 3960 October, 1976 $x \cdot m$ [mm]	Addendum reduction $k \cdot m$ [mm]	Tooth width b [mm]	Permissible tangential forces, normal [kN]	Permissible tangential forces, maximum [kN]	Curves
012.50.2559.201.49.1502	1892	2725	2250	185	2670	2410	60	33	30	6	2522	2524	138	178	7	47	2268	18	126	-9,0	-	138	216,0	432,0	47
012.50.3520.001.49.1502	2657	3685	3200	185	3630	3370	78	33	30	6	3482	3485	138	178	7	47	3220	20	161	-10,0	-	138	240,0	480,0	48
012.50.3739.001.49.1502	2823	3905	3420	185	3850	3590	84	33	30	6	3701	3704	138	178	7	47	3440	20	172	-10,0	-	138	240,0	480,0	49
012.50.3839.001.49.1502	2905	4005	3520	185	3950	3690	84	33	30	6	3801	3804	138	178	7	47	3540	20	177	-10,0	-	138	240,0	480,0	50

Gear quenched and tempered

Static limiting load curves

—— Raceway - - - Bolts

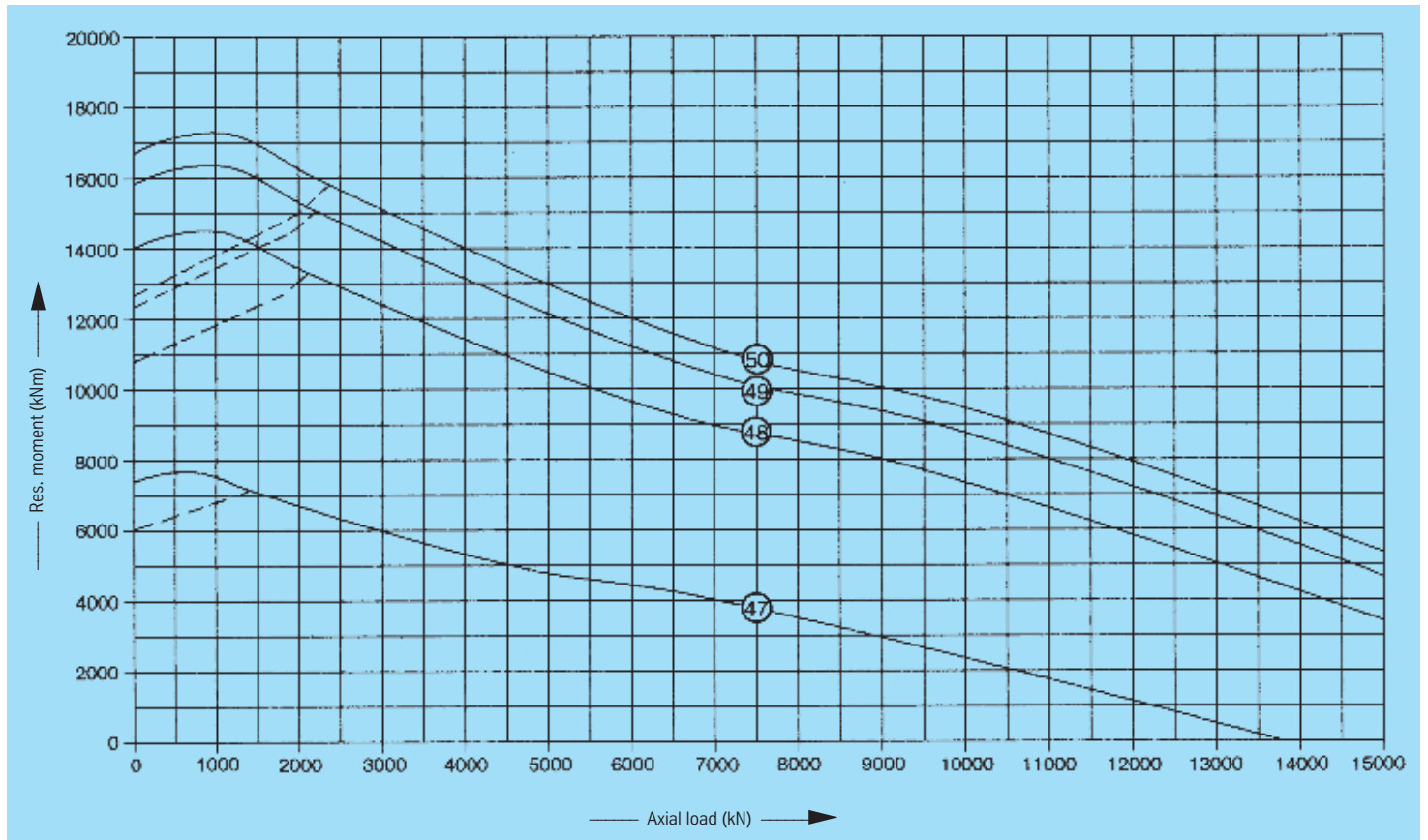

Standard series KD 320



Rothe Erde
Slewing Bearings

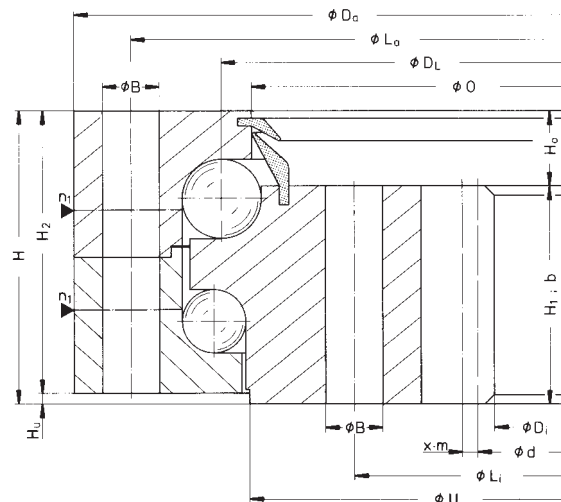

Service life curves · 30,000 revolutions

drawing position = mounting position

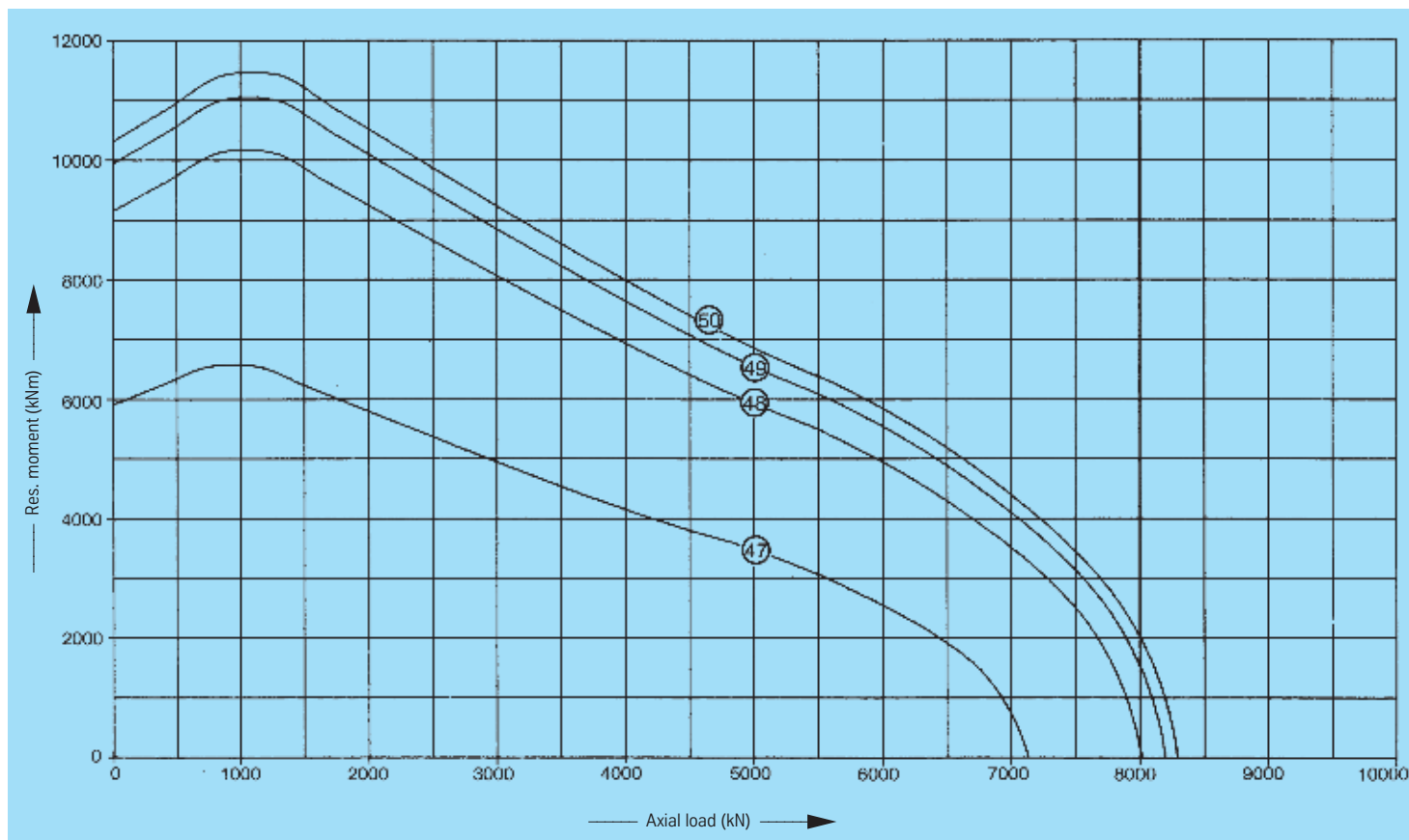



Rothe Erde
Slewing Bearings

Standard series KD 600

Single-row bearing slewing rings
Four-point contact bearings

Pages 85 – 121

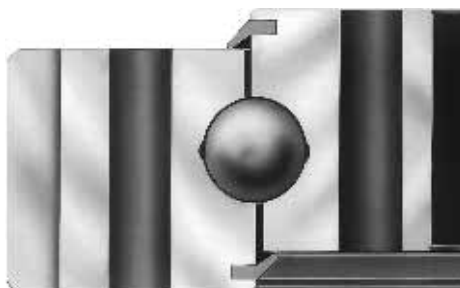
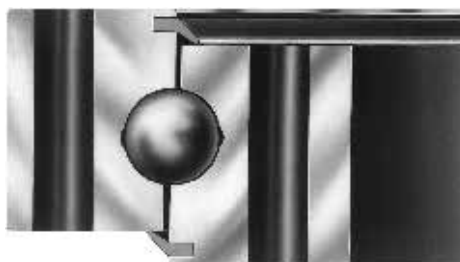

Standard series KD 600



Rothe Erde
Slewing Bearings

Bearing ungeared

Drawing No. Ball track dia. D_L [mm]	Weight [kg]	Outer diameter (O.D.) D_o [mm]	Inner diameter (I.D.) D_i [mm]	Overall height H [mm]	External bolt circle dia. L_e [mm]	Internal bolt circle dia. L_i [mm]	Number of bolt holes per hole circle n	Bolt hole diameter B [mm]	Bolt size M [mm]	Number of grease nipples per level n_1	Diameter O [mm]	Diameter U [mm]	Ring height H_1 [mm]	Ring height H_2 [mm]	Distance at bottom Outer ring/inner ring H_b [mm]	Distance at top Outer ring/inner ring H_o [mm]	Gear P.C.D. d [mm]	Module m [mm]	Number of teeth z	Addendum modification sign per DIN 3960 October, 1976 $x \cdot m$ [mm]	Addendum reduction $k \cdot m$ [mm]	Tooth width b [mm]	Permissible tangential forces, normal [kN]	Permissible tangential forces, maximum [kN]	Curves	
060.22.0370.301.11.1504	35	456	289	59	425	320	16	1,5	16	4	371	369	50	50	9	9	-	-	-	-	-	-	-	-	-	①
060.22.0505.000.11.1503	44	585	425	58	555	455	22	17,5	16	2	506	504	49	49	9	9	-	-	-	-	-	-	-	-	-	②
060.22.0575.502.11.1503	52	655	500	62	625	525	12	-	16	4	576	574	49	49	13	13	-	-	-	-	-	-	-	-	-	③
060.22.0660.001.11.1503	59	740	580	58	710	610	30	17,5	16	2	657	659	49	49	9	9	-	-	-	-	-	-	-	-	-	④

Static limiting load curves

—— Raceway - - - Bolts

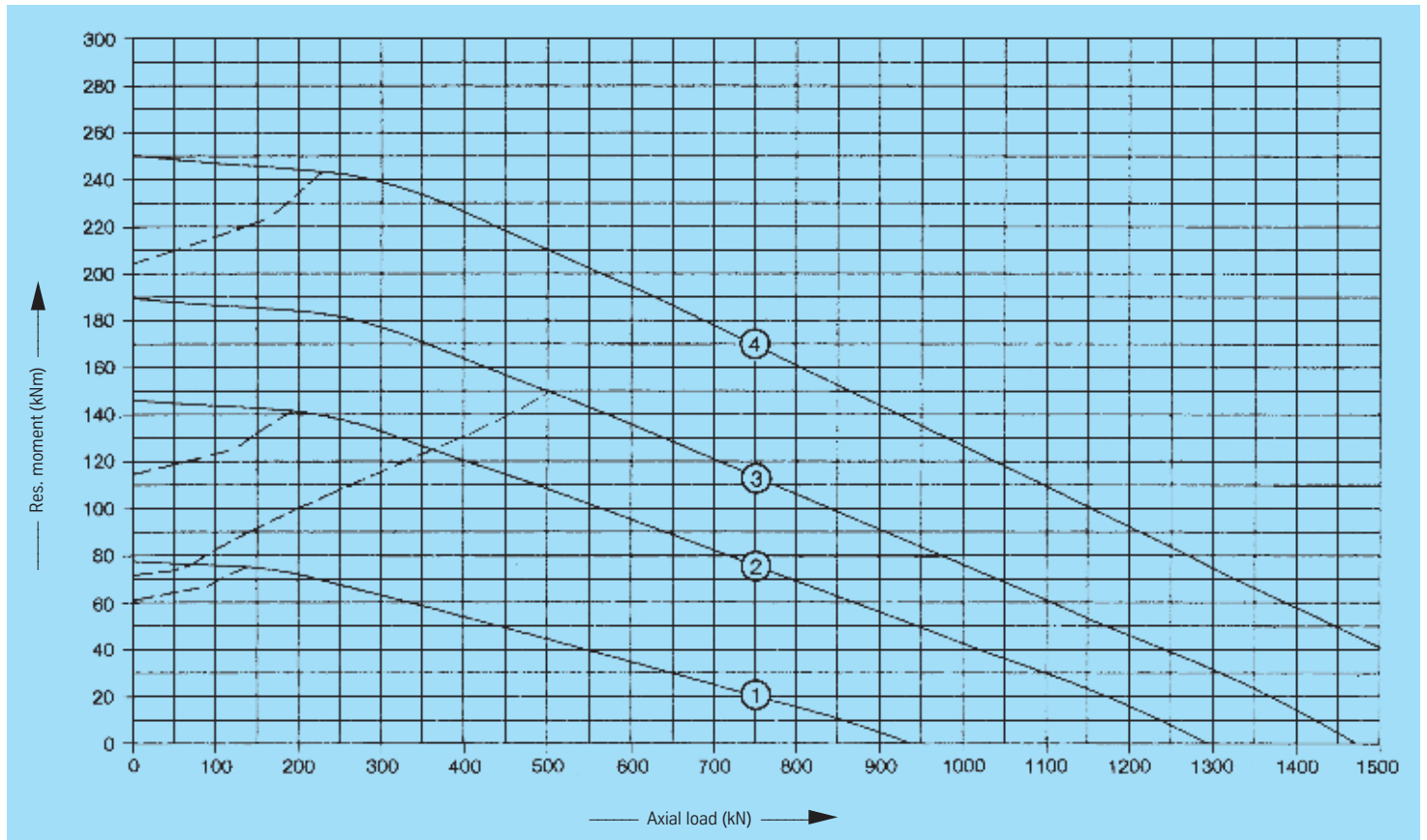

Standard series KD 600



Rothe Erde
Slewing Bearings

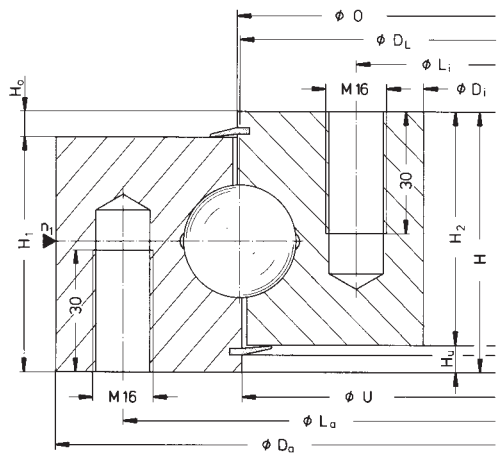

Drawing number **060.22.0575.502.11.1504**

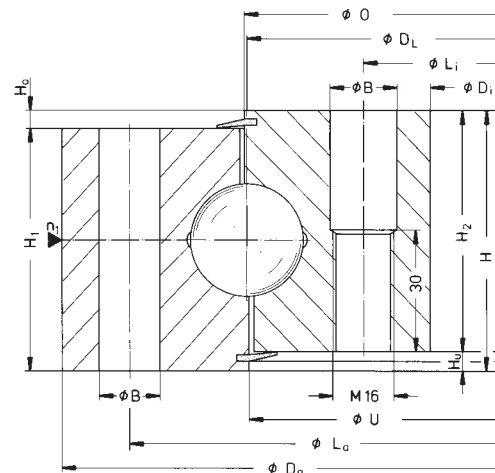

Drawing number **060.22.0370.301.11.1504**
060.22.0505.000.11.1503
060.22.0660.001.11.1503

Service life curves · 30,000 revolutions

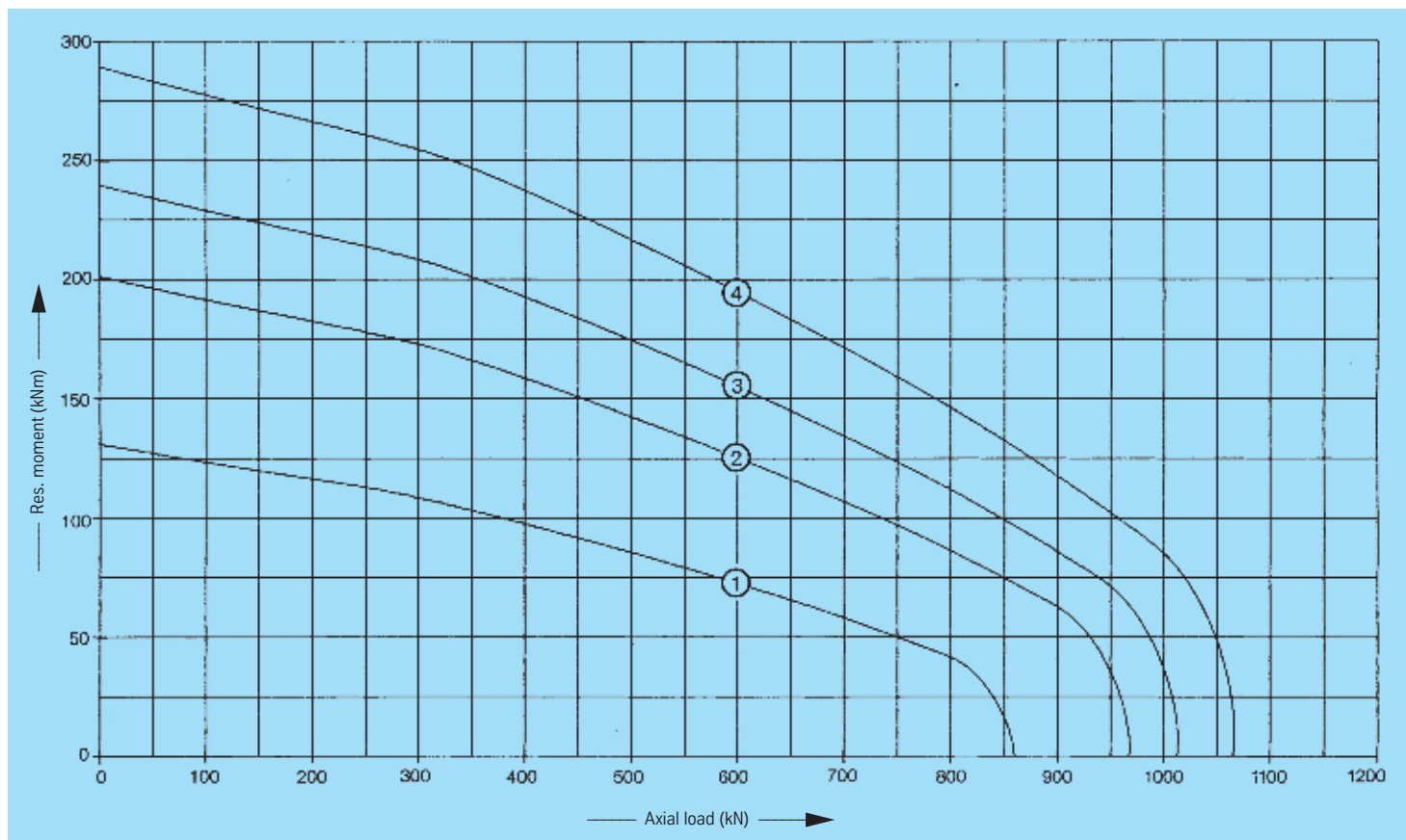

Standard series KD 600



Rothe Erde
Slewing Bearings

Bearing ungeared

Drawing No. Ball track dia. D_L [mm]	Weight [kg]	Outer diameter (O.D.) D_o [mm]	Inner diameter (I.D.) D_i [mm]	Overall height H [mm]	External bolt circle dia. L_e [mm]	Internal bolt circle dia. L_i [mm]	Number of bolt holes per hole circle n	Bolt hole diameter B [mm]	Bolt size M [mm]	Number of grease nipples per level n_1	Diameter O [mm]	Diameter U [mm]	Ring height H_1 [mm]	Ring height H_2 [mm]	Distance at bottom Outer ring/inner ring H_b [mm]	Distance at top Outer ring/inner ring H_o [mm]	Gear P.C.D. d [mm]	Module m [mm]	Number of teeth z	Addendum modification sign per DIN 3960 October, 1976 $x \cdot m$ [mm]	Addendum reduction $k \cdot m$ [mm]	Tooth width b [mm]	Permissible tangential forces, normal [kN]	Permissible tangential forces, maximum [kN]	Curves	
060.25.0475.000.11.1504	50	565	385	64	535	415	30	17,5	16	3	476	474	57	57	7	7	-	-	-	-	-	-	-	-	-	5
060.25.0555.000.11.1504	61	650	460	63	614	496	30	17,5	16	3	556	554	54	54	9	9	-	-	-	-	-	-	-	-	-	6
060.30.0550.100.11.1504	73	650	450	75	615	485	24	22	20	4	548	552	65	65	10	10	-	-	-	-	-	-	-	-	-	7
060.35.0680.000.11.1503	131	800	560	82	755	605	20	22	20	4	681	678	73	73	9	9	-	-	-	-	-	-	-	-	-	8
060.45.0805.001.11.1504	215	948	662	99	896	714	30	26	24	4	807	803	90	90	9	9	-	-	-	-	-	-	-	-	-	9

Static limiting load curves

—— Raceway - - - Bolts

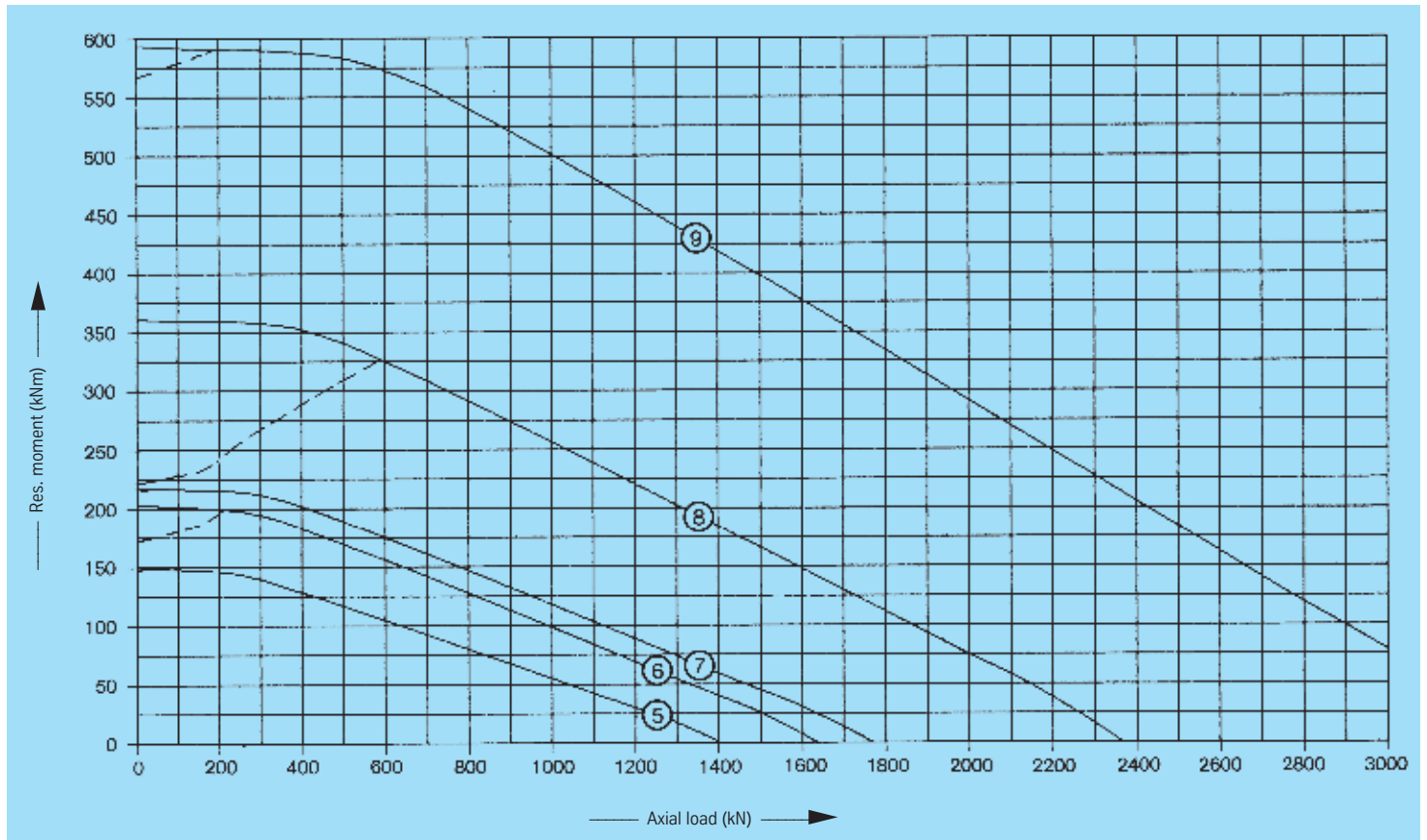

Standard series KD 600



Rothe Erde
Slewing Bearings

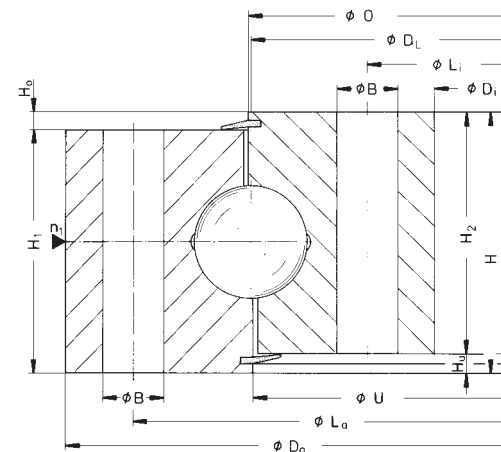

Service life curves · 30,000 revolutions

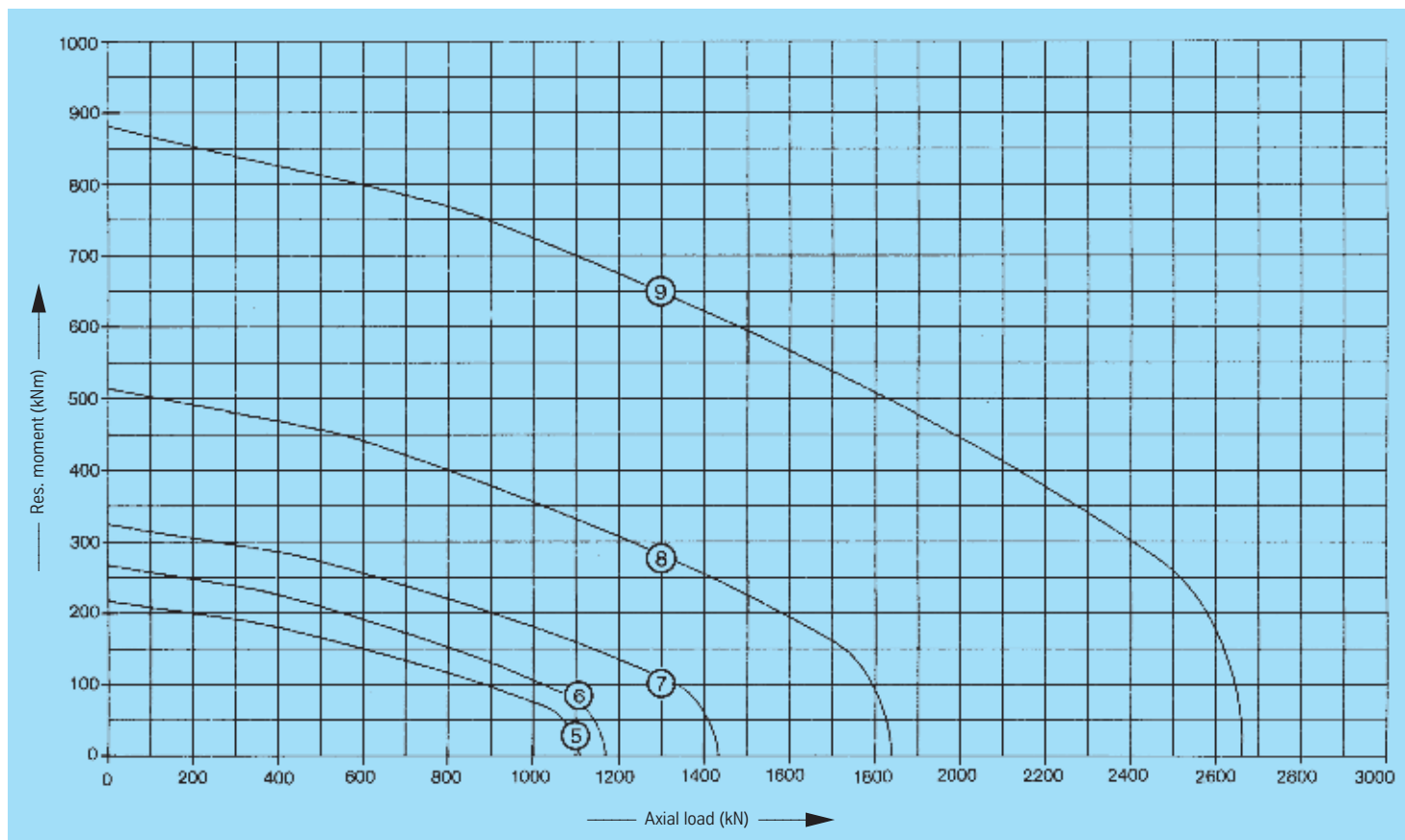

Standard series KD 600

Standard bearings type 621, standard bearing



Rothe Erde
Slewing Bearings

Bearing ungeared

Drawing No. Ball track diameter D_L [mm]	Weight Outer diameter (O.D.) D_a [mm]	Inner diameter (I.D.) D_i [mm]	Overall height H [mm]	External bolt circle diameter L_a [mm]	Internal bolt circle diameter L_i [mm]	Number of bolt holes per hole circle n *	Bolt hole diameter B [mm]	Both size M [mm]	t [mm]	Diameter O [mm]	Diameter U [mm]	Ring height H₁ [mm]	Ring height H₂ [mm]	Distance at bottom Outer ring/inner ring H_u [mm]	Distance at top Outer ring/inner ring H_o [mm]	Gear P.C.D. d [mm]	Module m [mm]	Number of teeth z	Addendum modification system DIN 3960 October, 1976 x · m [mm]	Addendum reduction k · m [mm]	Tooth width b [mm]	Permissible tangential forces, normal [kN]	Permissible tangential forces, maximum [kN]	Bearing clearances ①		Curves	
																								axial [mm]	radial [mm]		
060.20.0414.500.01.1503	29	486	342	56	460	368	24	13,5	12	-	412,5	415,5	45,5	45,5	10,5	10,5	-	-	-	-	-	-	-	-	≤ 0,28	≤ 0,24	①
060.20.0544.500.01.1503	37	616	472	56	590	498	32	13,5	12	-	542,5	545,5	45,5	45,5	10,5	10,5	-	-	-	-	-	-	-	-	≤ 0,30	≤ 0,26	②
060.20.0644.500.01.1503	44	716	572	56	690	598	36	13,5	12	-	642,5	645,5	45,5	45,5	10,5	10,5	-	-	-	-	-	-	-	-	≤ 0,30	≤ 0,26	③
060.20.0744.500.01.1503	52	816	672	56	790	698	40	13,5	12	-	742,5	745,5	45,5	45,5	10,5	10,5	-	-	-	-	-	-	-	-	≤ 0,30	≤ 0,26	④
060.20.0844.500.01.1503	60	916	772	56	890	798	40	13,5	12	-	842,5	845,5	45,5	45,5	10,5	10,5	-	-	-	-	-	-	-	-	≤ 0,30	≤ 0,26	⑤
060.20.0944.500.01.1503	67	1016	872	56	990	898	44	13,5	12	-	942,5	945,5	45,5	45,5	10,5	10,5	-	-	-	-	-	-	-	-	≤ 0,30	≤ 0,26	⑥
060.20.1094.500.01.1503	77	1166	1022	56	1140	1048	48	13,5	12	-	1092,5	1095,5	45,5	45,5	10,5	10,5	-	-	-	-	-	-	-	-	≤ 0,30	≤ 0,26	⑦

① Axial clearance = tilting clearance

Bearings with external gear

061.20.0414.500.01.1503	31	504	342	56	455	368	20/24	13,5	12	20	412,5	415,5	45,5	45,5	10,5	10,5	495	5	99	-	-0,5	45,5	11,75	23,50	≤ 0,28	≤ 0,24	①
061.20.0544.500.01.1503	43	640,8	472	56	585	498	28/32	13,5	12	20	542,5	545,5	45,5	45,5	10,5	10,5	630	6	105	-	-0,6	45,5	14,20	28,40	≤ 0,30	≤ 0,26	②
061.20.0644.500.01.1503	52	742,8	572	56	685	598	32/36	13,5	12	20	642,5	645,5	45,5	45,5	10,5	10,5	732	6	122	-	-0,6	45,5	14,20	28,40	≤ 0,30	≤ 0,26	③
061.20.0744.500.01.1503	59	838,8	672	56	785	698	36/40	13,5	12	20	742,5	745,5	45,5	45,5	10,5	10,5	828	6	138	-	-0,6	45,5	14,20	28,40	≤ 0,30	≤ 0,26	④
061.20.0844.500.01.1503	71	950,4	772	56	885	798	36/40	13,5	12	20	842,5	845,5	45,5	45,5	10,5	10,5	936	8	117	-	-0,8	45,5	18,93	37,86	≤ 0,30	≤ 0,26	⑤
061.20.0944.500.01.1503	77	1046,4	872	56	985	898	40/44	13,5	12	20	942,5	945,5	45,5	45,5	10,5	10,5	1032	8	129	-	-0,8	45,5	18,93	37,86	≤ 0,30	≤ 0,26	⑥
061.20.1094.500.01.1503	91	1198,4	1022	56	1135	1048	44/48	13,5	12	20	1092,5	1095,5	45,5	45,5	10,5	10,5	1184	8	148	-	-0,8	45,5	18,93	37,86	≤ 0,30	≤ 0,26	⑦

▲ n* = Number of bolt holes
L_j/L_i

Gear normalized

Bearings with internal gear

062.20.0414.500.01.1503	31	486	326,5	56	460	375	24	13,5	12	20	415,5	412,5	45,5	45,5	10,5	10,5	335	5	67	-	-0,75	45,5	13,54	27,08	≤ 0,28	≤ 0,24	①
062.20.0544.500.01.1503	42	616	445,2	56	590	505	32	13,5	12	20	545,5	542,5	45,5	45,5	10,5	10,5	456	6	76	-	-0,6	45,5	16,00	32,00	≤ 0,30	≤ 0,26	②
062.20.0644.500.01.1503	50	716	547,2	56	690	605	36	13,5	12	20	645,5	642,5	45,5	45,5	10,5	10,5	558	6	93	-	-0,6	45,5	15,62	31,24	≤ 0,30	≤ 0,26	③
062.20.0744.500.01.1503	58	816	649,2	56	790	705	40	13,5	12	20	745,5	742,5	45,5	45,5	10,5	10,5	660	6	110	-	-0,6	45,5	15,32	30,64	≤ 0,30	≤ 0,26	④
062.20.0844.500.01.1503	69	916	737,6	56	890	805	40	13,5	12	20	845,5	842,5	45,5	45,5	10,5	10,5	752	8	94	-	-0,8	45,5	20,80	41,60	≤ 0,30	≤ 0,26	⑤
062.20.0944.500.01.1503	76	1016	841,6	56	990	905	44	13,5	12	20	945,5	942,5	45,5	45,5	10,5	10,5	856	8	107	-	-0,8	45,5	20,49	40,98	≤ 0,30	≤ 0,26	⑥
062.20.1094.500.01.1503	91	1166	985,6	56	1140	1055	48	13,5	12	20	1095,5	1092,5	45,5	45,5	10,5	10,5	1000	8	125	-	-0,8	45,5	20,16	40,32	≤ 0,30	≤ 0,26	⑦

Standard series KD 600

Standard bearings type 621, standard bearing

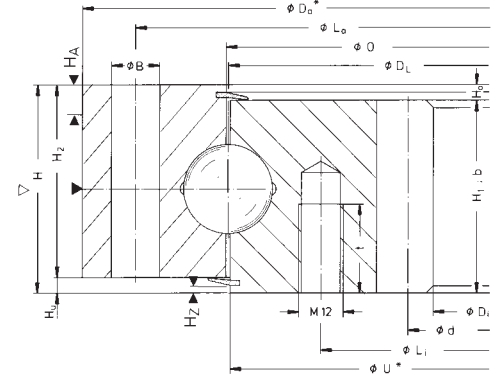
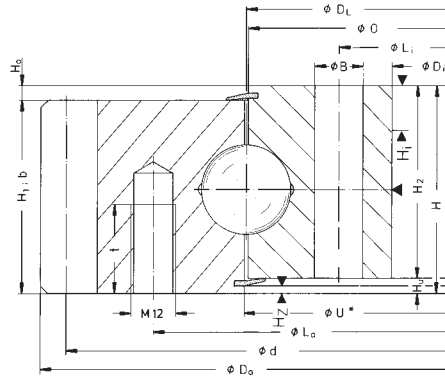
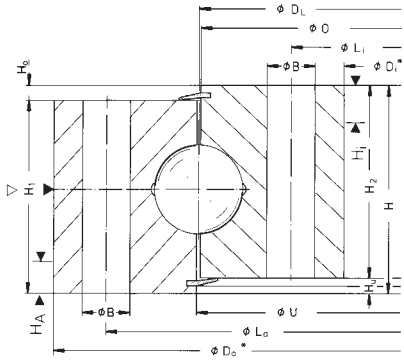

* If pilots are required on standard bearings, it is essential that is indicated at the time of ordering.
Pilots can only be provided at nominal diameters marked with an *.

Pilot tolerances:	Outside	Inside
D _i 414 544	-0.5 mm	+0.5 mm
D _i 644 844	-0.6 mm	+0.6 mm
D _i 944 1094	-0.7 mm	+0.7 mm

Pilot height $H_2 = 4.5$ mm
Pilot height $H_{A_i} = 10$ mm
Pilot height of companion structure
= $(H_2 - 1)$ or $(H_{A_i} - 1)$ respectively mm

- ▶ = 4 equispaced conical grease nipple AM 10 x 1 DIN 71412 countersunk, when they are fitted on the outer bearing diameter
- ▽ = Filler plug

Static limiting load curves

—— Raceway - - - Bolts

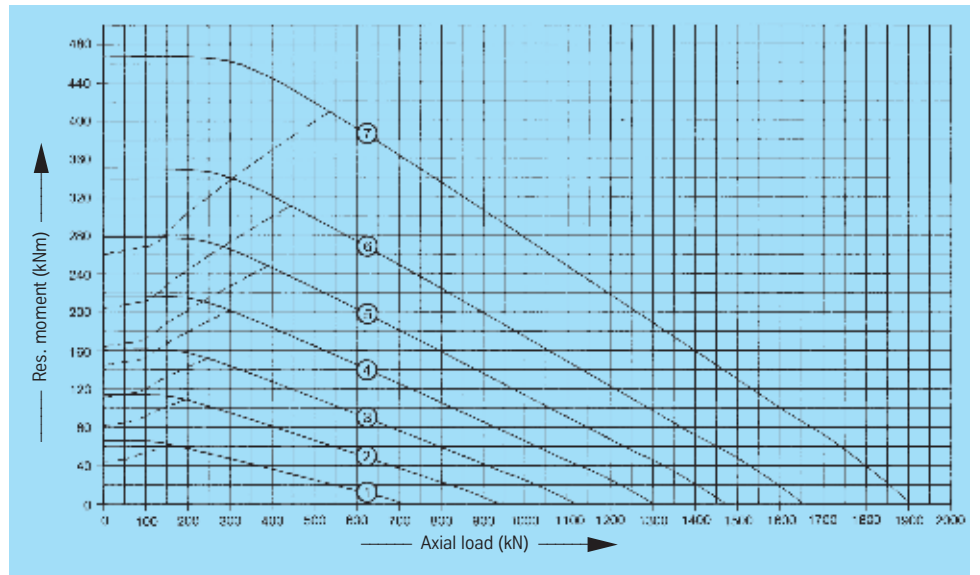

Service life curves · 30,000 revolutions

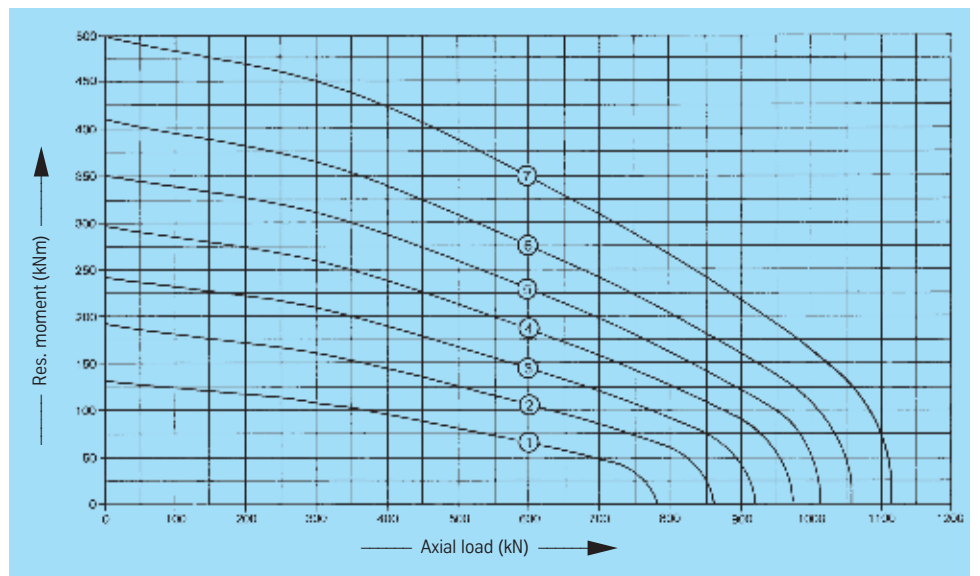

Standard series KD 600

Standard bearing type 621, Bearing with limited clearance



Rothe Erde
Slewing Bearings

Bearing ungeared

Drawing No.	Weight	Outer diameter (O.D.)*	Inner diameter (I.D.)*	Overall height	External bolt circle diameter	Internal bolt circle diameter	Number of bolt holes per hole circle	Bolt hole diameter	Bolt hole	t	O	U	H ₁	H ₂	H _u	H _o	Gear P.C.D.-	Module	Number of teeth	Addendum modification sign per DIN 3960 October 1976	Addendum reduction	Tooth width	Permissible tangential forces, normal	Permissible tangential forces, maximum	Bearing clearances ①	Curves	
D _L [mm]	[kg]	D _a [mm]	D _i [mm]	H [mm]	L _e [mm]	L _i [mm]	n	B	M	t	O	U	H ₁	H ₂	H _u	H _o	d	m	z	x	k	m	b	[kN]	[kN]	axial and radial [mm]	
060.20.0414.575.01.1403	29	484,5 -0,10	343,5 +0,09	56	460	368	24	13,5	12	-	412,5	415,5	45,5	45,5	10,5	10,5	-	-	-	-	-	-	-	-	-	≥ 0 to 0,03	①
060.20.0544.575.01.1403	37	614,5 -0,11	473,5 +0,10	56	590	498	32	13,5	12	-	542,5	545,5	45,5	45,5	10,5	10,5	-	-	-	-	-	-	-	-	-	≥ 0 to 0,03	②
060.20.0644.575.01.1403	44	714,5 -0,13	573,5 +0,11	56	690	598	36	13,5	12	-	642,5	645,5	45,5	45,5	10,5	10,5	-	-	-	-	-	-	-	-	-	≥ 0 to 0,04	③
060.20.0744.575.01.1403	52	814,5 -0,14	673,5 +0,13	56	790	698	40	13,5	12	-	742,5	745,5	45,5	45,5	10,5	10,5	-	-	-	-	-	-	-	-	-	≥ 0 to 0,04	④
060.20.0844.575.01.1403	60	914,5 -0,14	773,5 +0,13	56	890	798	40	13,5	12	-	842,5	845,5	45,5	45,5	10,5	10,5	-	-	-	-	-	-	-	-	-	≥ 0 to 0,05	⑤
060.20.0944.575.01.1403	67	1014,5 -0,17	873,5 +0,14	56	990	898	44	13,5	12	-	942,5	945,5	45,5	45,5	10,5	10,5	-	-	-	-	-	-	-	-	-	≥ 0 to 0,05	⑥
060.20.1094.575.01.1403	77	1164,5 -0,17	1023,5 +0,17	56	1140	1048	48	13,5	12	-	1092,5	1095,5	45,5	45,5	10,5	10,5	-	-	-	-	-	-	-	-	-	≥ 0 to 0,06	⑦

① Axial clearance = tilting clearance

Bearings with external gear

061.20.0414.575.01.1403	31	504	343,5 +0,09	56	455	368	20/24	13,5	12	20	412,5	417 +0,10	45,5	45,5	10,5	10,5	495	5	99	-	-0,5	45,5	11,75	23,50	≥ 0 to 0,03	①
061.20.0544.575.01.1403	43	640,8	473,5 +0,10	56	585	498	28/32	13,5	12	20	542,5	547 +0,11	45,5	45,5	10,5	10,5	630	6	105	-	-0,6	45,5	14,20	28,40	≥ 0 to 0,03	②
061.20.0644.575.01.1403	52	742,8	573,5 +0,11	56	685	598	32/36	13,5	12	20	642,5	647 +0,13	45,5	45,5	10,5	10,5	732	6	122	-	-0,6	45,5	14,20	28,40	≥ 0 to 0,04	③
061.20.0744.575.01.1403	59	838,8	673,5 +0,13	56	785	698	36/40	13,5	12	20	742,5	747 +0,13	45,5	45,5	10,5	10,5	828	6	138	-	-0,6	45,5	14,20	28,40	≥ 0 to 0,04	④
061.20.0844.575.01.1403	71	950,4	773,5 +0,13	56	885	798	36/40	13,5	12	20	842,5	847 +0,14	45,5	45,5	10,5	10,5	936	8	117	-	-0,8	45,5	18,93	37,86	≥ 0 to 0,05	⑤
061.20.0944.575.01.1403	77	1046,4	873,5 +0,14	56	985	898	40/44	13,5	12	20	942,5	947 +0,14	45,5	45,5	10,5	10,5	1032	8	129	-	-0,8	45,5	18,93	37,86	≥ 0 to 0,05	⑥
061.20.1094.575.01.1403	91	1198,4	1023,5 +0,17	56	1135	1048	44/48	13,5	12	20	1092,5	1097 +0,17	45,5	45,5	10,5	10,5	1184	8	148	-	-0,8	45,5	18,93	37,86	≥ 0 to 0,06	⑦

▲ n* = Number of bolt holes
L_e/L_i

Gear normalized

Bearings with internal gear

062.20.0414.575.01.1403	31	484,5 -0,10	326,5	56	460	375	24	13,5	12	20	415,5	411 -0,10	45,5	45,5	10,5	10,5	335	5	67	-	-0,75	45,5	13,54	27,08	≥ 0 to 0,03	①
062.20.0544.575.01.1403	42	614,5 -0,11	445,2	56	590	505	32	13,5	12	20	545,5	541 -0,11	45,5	45,5	10,5	10,5	456	6	76	-	-0,6	45,5	16,00	32,00	≥ 0 to 0,03	②
062.20.0644.575.01.1403	50	714,5 -0,13	547,2	56	690	605	36	13,5	12	20	645,5	641 -0,13	45,5	45,5	10,5	10,5	558	6	93	-	-0,6	45,5	15,62	31,24	≥ 0 to 0,04	③
062.20.0744.575.01.1403	58	814,5 -0,14	649,2	56	790	705	40	13,5	12	20	745,5	741 -0,13	45,5	45,5	10,5	10,5	660	6	110	-	-0,6	45,5	15,32	30,64	≥ 0 to 0,04	④
062.20.0844.575.01.1403	69	914,5 -0,14	737,6	56	890	805	40	13,5	12	20	845,5	841 -0,14	45,5	45,5	10,5	10,5	752	8	94	-	-0,8	45,5	20,80	41,60	≥ 0 to 0,05	⑤
062.20.0944.575.01.1403	76	1014,5 -0,17	841,6	56	990	905	44	13,5	12	20	945,5	941 -0,14	45,5	45,5	10,5	10,5	856	8	107	-	-0,8	45,5	20,49	40,98	≥ 0 to 0,05	⑥
062.20.1094.575.01.1403	91	1164,5 -0,17	985,6	56	1140	1055	48	13,5	12	20	1095,5	1091 -0,17	45,5	45,5	10,5	10,5	1000	8	125	-	-0,8	45,5	20,16	40,32	≥ 0 to 0,06	⑦

* Tolerances are valid for H, H_A, H_Z

Gear normalized

Standard series KD 600

Standard bearing type 621, Bearing with limited clearance

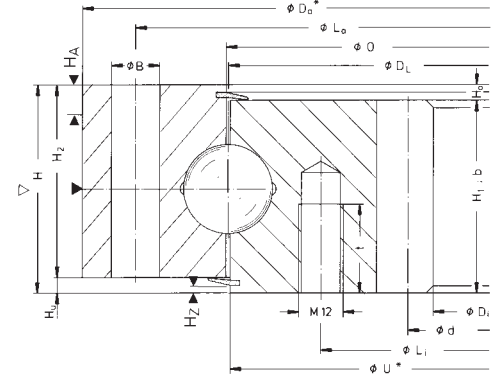
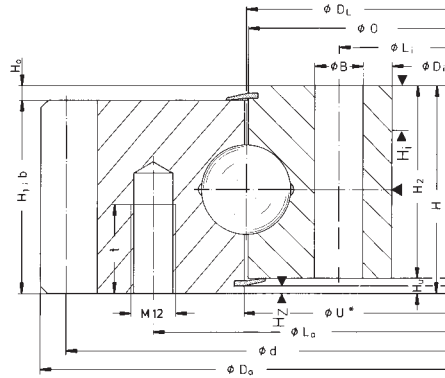
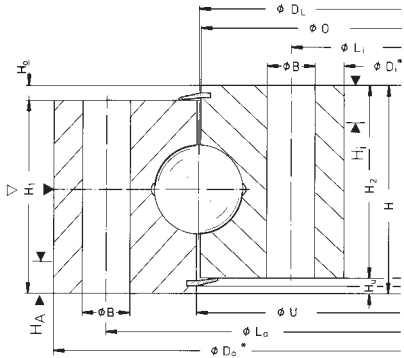

Static limiting load curves

— Raceway - - - Bolts

Pilot height $H_2 = 4.5$ mm
 Pilot height $H_{A,i} = 10$ mm
 Pilot height of companion structure
 = $(H_2 - 1)$ or $(H_{A,i} - 1)$ respectively mm

▶ = 4 equispaced conical grease nipple
 AM 10 x 1 DIN 71412
 countersunk, when they are fitted on
 the outer bearing diameter
 ▽ = Filler plug

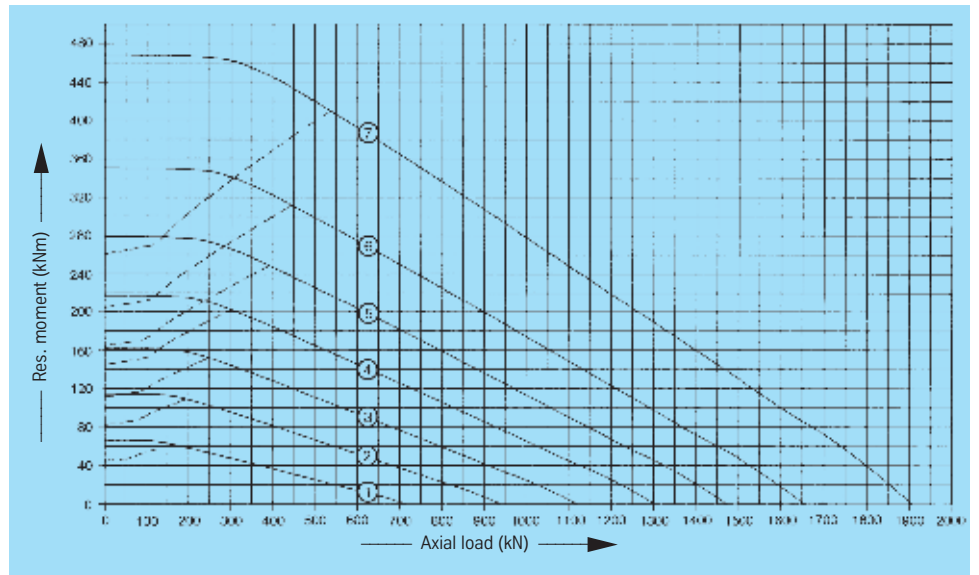

Service life curves · 30,000 revolutions

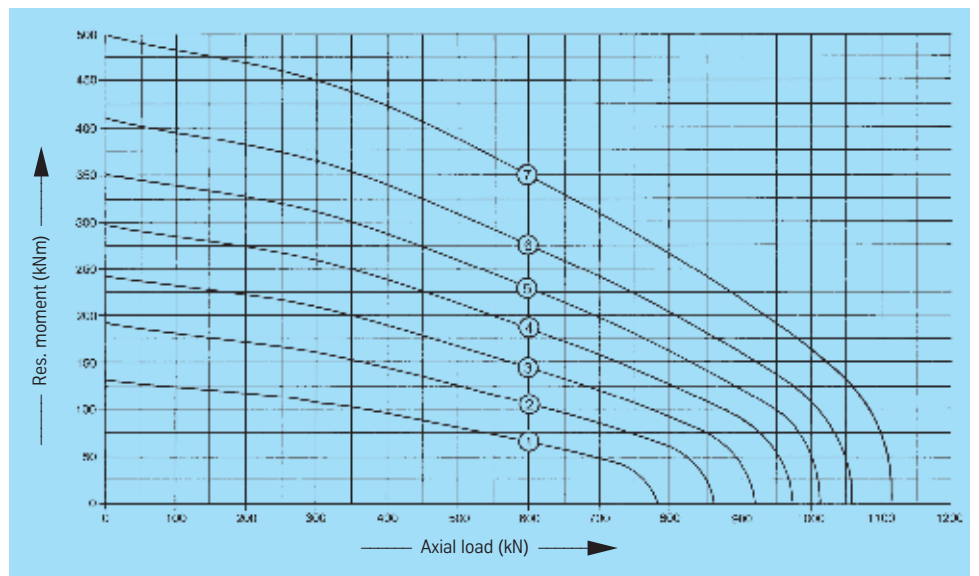

Standard series KD 600

Standard bearing type 625, standard bearing



Rothe Erde
Slewing Bearings

Bearing ungeared

Drawing No. Ball track diameter D_t [mm]	Weight Outer diameter (O.D.) D_o [mm]	Inner diameter (I.D.) D_i [mm]	Overall height H [mm]	External bolt circle diameter L_e [mm]	Internal bolt circle diameter L_i [mm]	Number of bolt holes per hole circle n *	Bolt hole diameter B [mm]	Bolt size			Number of grease nipples n_1	Diameter O [mm]	Diameter U [mm]	Ring height H_1 [mm]	Ring height H_2 [mm]	Distance at bottom Outer ring/inner ring H_u [mm]	Distance at top Outer ring/inner ring H_o [mm]	Gear P.C.D.					Permissible tangential forces, normal [kN]	Permissible tangential forces, maximum [kN]	Bearing clearances ^①		Curves		
								d [mm]	m [mm]	z [mm]								$x \cdot m$ [mm]	$k \cdot m$ [mm]	b [mm]	axial [mm]	radial [mm]							
060.25.0855.500.11.1503	100	955	755	63	915	795	28	22	20	-	4	856	854	54	54	9	9	-	-	-	-	-	-	-	-	-	≤ 0,3	≤ 0,25	①
060.25.0955.500.11.1503	113	1055	855	63	1015	895	30	22	20	-	6	956	954	54	54	9	9	-	-	-	-	-	-	-	-	≤ 0,3	≤ 0,25	②	
060.25.1055.500.11.1503	124	1155	955	63	1115	995	30	22	20	-	6	1056	1054	54	54	9	9	-	-	-	-	-	-	-	-	≤ 0,3	≤ 0,25	③	
060.25.1155.500.11.1503	139	1255	1055	63	1215	1095	36	22	20	-	6	1156	1154	54	54	9	9	-	-	-	-	-	-	-	-	≤ 0,3	≤ 0,25	④	
060.25.1255.500.11.1503	148	1355	1155	63	1315	1195	42	22	20	-	6	1256	1254	54	54	9	9	-	-	-	-	-	-	-	-	≤ 0,36	≤ 0,3	⑤	
060.25.1355.500.11.1503	161	1455	1255	63	1415	1295	42	22	20	-	6	1356	1354	54	54	9	9	-	-	-	-	-	-	-	-	≤ 0,36	≤ 0,3	⑥	
060.25.1455.500.11.1503	171	1555	1355	63	1515	1395	48	22	20	-	6	1456	1454	54	54	9	9	-	-	-	-	-	-	-	-	≤ 0,36	≤ 0,3	⑦	

① Axial clearance = tilting clearance

Bearings with external gear

061.25.0855.500.11.1503	141	997,2	755	80	916	795	28	22	20	40	4	856	854	71	54	26	9	981	9	109	-	-0,9	71	33,23	66,46	≤ 0,3	≤ 0,25	①
061.25.0955.500.11.1503	158	1096,2	855	80	1016	895	30	22	20	40	6	956	954	71	54	26	9	1080	9	120	-	-0,9	71	33,23	66,46	≤ 0,3	≤ 0,25	②
061.25.1055.500.11.1503	172	1198	955	80	1116	995	30	22	20	40	6	1056	1054	71	54	26	9	1180	10	118	-	-1,0	71	36,92	73,84	≤ 0,3	≤ 0,25	③
061.25.1155.500.11.1503	190	1298	1055	80	1216	1095	36	22	20	40	6	1156	1154	71	54	26	9	1280	10	128	-	-1,0	71	36,92	73,84	≤ 0,3	≤ 0,25	④
061.25.1255.500.11.1503	204	1398	1155	80	1316	1195	42	22	20	40	6	1256	1254	71	54	26	9	1380	10	138	-	-1,0	71	36,92	73,84	≤ 0,36	≤ 0,3	⑤
061.25.1355.500.11.1503	222	1498	1255	80	1416	1295	42	22	20	40	6	1356	1354	71	54	26	9	1480	10	148	-	-1,0	71	36,92	73,84	≤ 0,36	≤ 0,3	⑥
061.25.1455.500.11.1503	236	1598	1355	80	1516	1395	48	22	20	40	6	1456	1454	71	54	26	9	1580	10	158	-	-1,0	71	36,92	73,84	≤ 0,36	≤ 0,3	⑦

▲ n^* = Number of bolt holes
 L_e/L_i

Gear normalized

Bearings with internal gear

062.25.0855.500.11.1503	133	955	710	80	915	794	28	22	20	40	4	854	856	71	54	26	9	730	10	73	-	-	71	38,46	76,92	≤ 0,3	≤ 0,25	①
062.25.0955.500.11.1503	150	1055	810	80	1015	894	30	22	20	40	6	954	956	71	54	26	9	830	10	83	-	-	71	38,46	76,92	≤ 0,3	≤ 0,25	②
062.25.1055.500.11.1503	166	1155	910	80	1115	994	30	22	20	40	6	1054	1056	71	54	26	9	930	10	93	-	-	71	38,46	76,92	≤ 0,3	≤ 0,25	③
062.25.1155.500.11.1503	183	1255	1010	80	1215	1094	36	22	20	40	6	1154	1156	71	54	26	9	1030	10	103	-	-	71	38,46	76,92	≤ 0,3	≤ 0,25	④
062.25.1255.500.11.1503	198	1355	1110	80	1315	1194	42	22	20	40	6	1254	1256	71	54	26	9	1130	10	113	-	-	71	38,46	76,92	≤ 0,36	≤ 0,3	⑤
062.25.1355.500.11.1503	215	1455	1210	80	1415	1294	42	22	20	40	6	1354	1356	71	54	26	9	1230	10	123	-	-	71	38,46	76,92	≤ 0,36	≤ 0,3	⑥
062.25.1455.500.11.1503	229	1555	1310	80	1515	1394	48	22	20	40	6	1454	1456	71	54	26	9	1330	10	133	-	-	71	38,46	76,92	≤ 0,36	≤ 0,3	⑦

Gear normalized

Standard series KD 600

Standard bearing type 625, standard bearing



Rothe Erde
Slewing Bearings

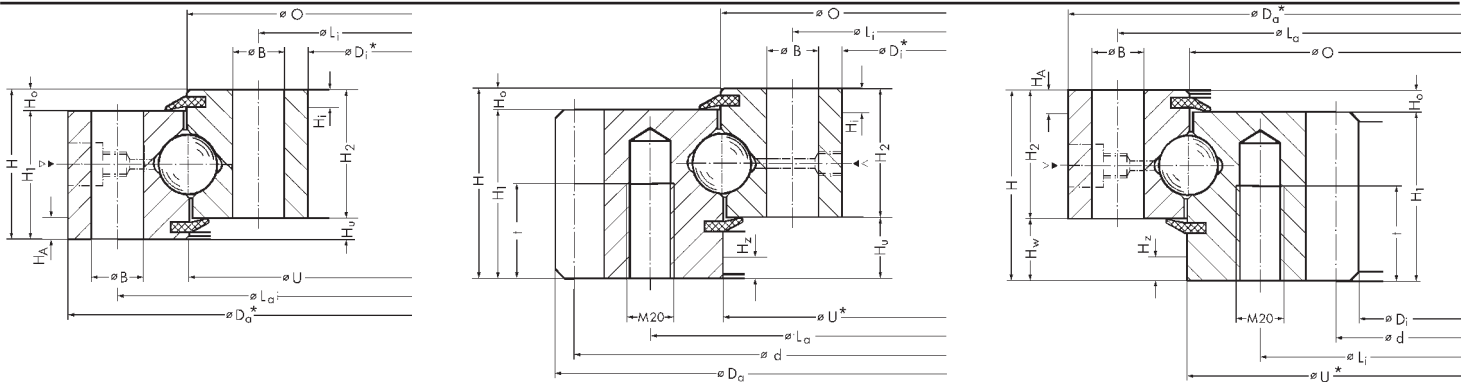

- ▶ $n_1 = 4$ equispaced conical grease nipple AM 10 x 1 DIN 71412 countersunk, when they are fitted on the outer bearing diameter
- ▷ = Filler plug

* If pilots are required on standard bearings, it is essential that is indicated at the time of ordering. Pilots can only be provided at nominal diameters marked with an *.

Pilot height
 $H_1 = 10$ mm
 $H_A = 10$ mm
 $H_2 = 10$ mm

Pilot height of companion structure
 $= H_1 - 1$ mm
 $= H_A - 1$ mm
 $= H_2 - 1$ mm

Bearing ungeared

centering	
D_a [mm]	D_i [mm]
953 -0,23	757 +0,23
1053 -0,26	857 +0,23
1153 -0,26	957 +0,23
1253 -0,31	1057 +0,26
1353 -0,31	1157 +0,26
1453 -0,31	1257 +0,26
1553 -0,31	1357 +0,26

Bearings with external gear

centering	
D_i [mm]	U [mm]
757 +0,23	855 +0,23
857 +0,23	955 +0,23
957 +0,23	1055 +0,26
1057 +0,26	1155 +0,26
1157 +0,26	1255 +0,31
1257 +0,26	1355 +0,31
1357 +0,26	1455 +0,31

Bearings with internal gear

centering	
D_a [mm]	U [mm]
953 -0,23	855 -0,23
1053 -0,26	955 -0,23
1153 -0,26	1055 -0,26
1253 -0,31	1155 -0,26
1353 -0,31	1255 -0,31
1453 -0,31	1355 -0,31
1553 -0,31	1455 -0,31

Static limiting load curves

— Raceway - - - Bolts

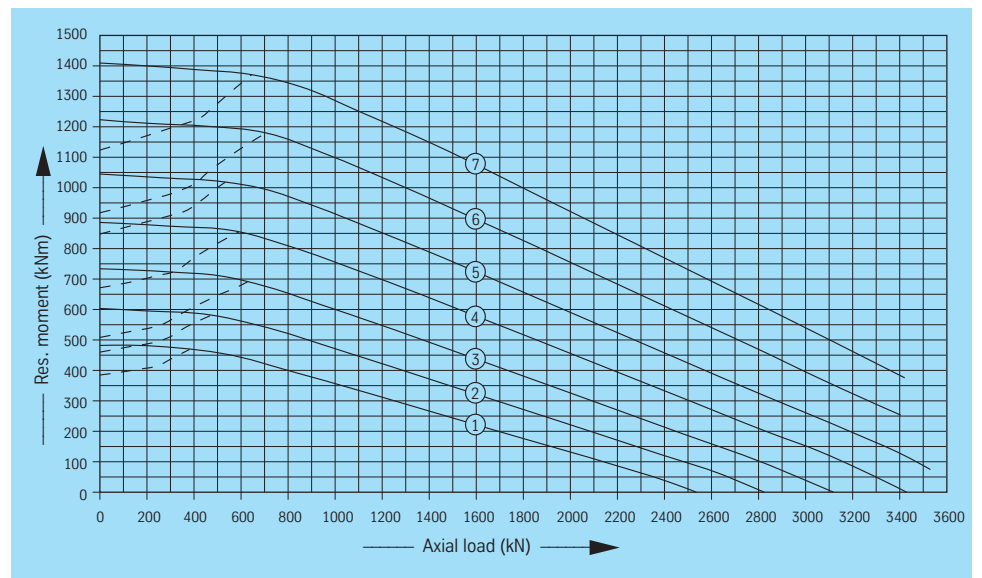

Service life curves · 30,000 revolutions

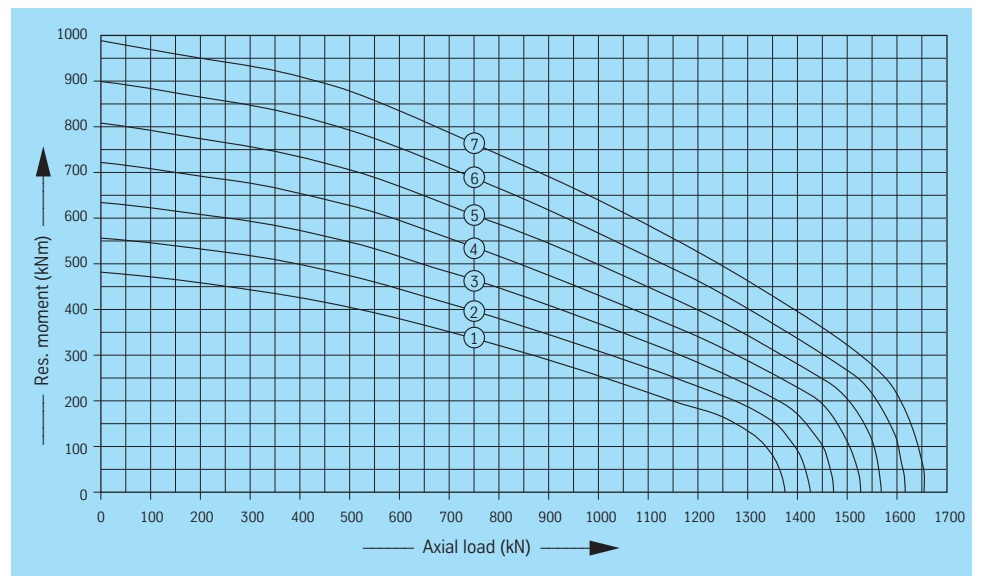

Standard series KD 600

Standard bearing type 625, Bearing with limited clearance



Rothe Erde
Slewing Bearings

Bearing ungeared

Drawing No.	Weight	Outer diameter (O.D.)*	Inner diameter (I.D.)*	Overall height	External bolt circle diameter	Internal bolt circle diameter	Number of bolt holes per hole circle	Bolt hole diameter	Bolt size	t	Number of grease nipples	Diameter	Diameter*	Ring height	Ring height	Distance at bottom Outer ring/inner ring	Distance at top Outer ring/inner ring	Gear P.C.D.	Module	Number of teeth	Addendum modification sign per DIN 3960 October 1976	Addendum reduction	Tooth width	Permissible tangential forces, normal	Permissible tangential forces, maximum	Bearing clearances ①	Curves	
D_L [mm]	[kg]	D_a [mm]	D_i [mm]	H [mm]	L_e [mm]	L_i [mm]	n *	B [mm]	M [mm]	t [mm]	n_1	O [mm]	U [mm]	H_1 [mm]	H_2 [mm]	H_u [mm]	H_o [mm]	d [mm]	m [mm]	z	x	k	m	b [mm]	[kN]	[kN]	axial and radial [mm]	
060.25.0855.575.11.1403	100	953 -0,14	757 +0,14	63	915	795	28	22	20	-	4	856	854	54	54	9	9	-	-	-	-	-	-	-	-	-	≥ 0 to 0,06	①
060.25.0955.575.11.1403	113	1053 -0,17	857 +0,14	63	1015	895	30	22	20	-	6	956	954	54	54	9	9	-	-	-	-	-	-	-	-	-	≥ 0 to 0,06	②
060.25.1055.575.11.1403	124	1153 -0,17	957 +0,14	63	1115	995	30	22	20	-	6	1056	1054	54	54	9	9	-	-	-	-	-	-	-	-	-	≥ 0 to 0,06	③
060.25.1155.575.11.1403	139	1253 -0,20	1057 +0,17	63	1215	1095	36	22	20	-	6	1156	1154	54	54	9	9	-	-	-	-	-	-	-	-	-	≥ 0 to 0,06	④
060.25.1255.575.11.1403	148	1353 -0,20	1157 +0,17	63	1315	1195	42	22	20	-	6	1256	1254	54	54	9	9	-	-	-	-	-	-	-	-	-	≥ 0 to 0,07	⑤
060.25.1355.575.11.1403	161	1453 -0,20	1257 +0,20	63	1415	1295	42	22	20	-	6	1356	1354	54	54	9	9	-	-	-	-	-	-	-	-	-	≥ 0 to 0,07	⑥
060.25.1455.575.11.1403	171	1553 -0,20	1357 +0,20	63	1515	1395	48	22	20	-	6	1456	1454	54	54	9	9	-	-	-	-	-	-	-	-	-	≥ 0 to 0,07	⑦

① Axial clearance = tilting clearance

Bearings with external gear

061.25.0855.575.11.1403	141	997,2	757 +0,14	80	916	795	28	22	20	40	4	856	855 +0,14	71	54	26	9	981	9	109	-	-0,9	71	33,23	66,46	≥ 0 to 0,06	①
061.25.0955.575.11.1403	158	1096,2	857 +0,14	80	1016	895	30	22	20	40	6	956	955 +0,14	71	54	26	9	1080	9	120	-	-0,9	71	33,23	66,46	≥ 0 to 0,06	②
061.25.1055.575.11.1403	172	1198	957 +0,14	80	1116	995	30	22	20	40	6	1056	1055 +0,17	71	54	26	9	1180	10	118	-	-1,0	71	36,92	73,84	≥ 0 to 0,06	③
061.25.1155.575.11.1403	190	1298	1057 +0,17	80	1216	1095	36	22	20	40	6	1156	1155 +0,17	71	54	26	9	1280	10	128	-	-1,0	71	36,92	73,84	≥ 0 to 0,06	④
061.25.1255.575.11.1403	204	1398	1157 +0,17	80	1316	1195	42	22	20	40	6	1256	1255 +0,20	71	54	26	9	1380	10	138	-	-1,0	71	36,92	73,84	≥ 0 to 0,07	⑤
061.25.1355.575.11.1403	222	1498	1257 +0,20	80	1416	1295	42	22	20	40	6	1356	1355 +0,20	71	54	26	9	1480	10	148	-	-1,0	71	36,92	73,84	≥ 0 to 0,07	⑥
061.25.1455.575.11.1403	236	1598	1357 +0,20	80	1516	1395	48	22	20	40	6	1456	1455 +0,20	71	54	26	9	1580	10	158	-	-1,0	71	36,92	73,84	≥ 0 to 0,07	⑦

▲ n* = Number of bolt holes
 L_e/L_i

Gear normalized

Bearings with internal gear

062.25.0855.575.11.1403	133	953 -0,14	710	80	915	794	28	22	20	40	4	854	855 -0,14	71	54	26	9	730	10	73	-	-	71	38,46	76,92	≥ 0 to 0,06	①
062.25.0955.575.11.1403	150	1053 -0,17	810	80	1015	894	30	22	20	40	6	954	955 -0,14	71	54	26	9	830	10	83	-	-	71	38,46	76,92	≥ 0 to 0,06	②
062.25.1055.575.11.1403	166	1153 -0,17	910	80	1115	994	30	22	20	40	6	1054	1055 -0,17	71	54	26	9	930	10	93	-	-	71	38,46	76,92	≥ 0 to 0,06	③
062.25.1155.575.11.1403	183	1253 -0,20	1010	80	1215	1094	36	22	20	40	6	1154	1155 -0,17	71	54	26	9	1030	10	103	-	-	71	38,46	76,92	≥ 0 to 0,06	④
062.25.1255.575.11.1403	198	1353 -0,20	1110	80	1315	1194	42	22	20	40	6	1254	1255 -0,20	71	54	26	9	1130	10	113	-	-	71	38,46	76,92	≥ 0 to 0,07	⑤
062.25.1355.575.11.1403	215	1453 -0,20	1210	80	1415	1294	42	22	20	40	6	1354	1355 -0,20	71	54	26	9	1230	10	123	-	-	71	38,46	76,92	≥ 0 to 0,07	⑥
062.25.1455.575.11.1403	229	1553 -0,20	1310	80	1515	1394	48	22	20	40	6	1454	1455 -0,20	71	54	26	9	1330	10	133	-	-	71	38,46	76,92	≥ 0 to 0,07	⑦

* Tolerances are valid for H , H_a , H_z

Gear normalized

Standard series KD 600

Standard bearing type 625, Bearing with limited clearance



Rothe Erde
Slewing Bearings

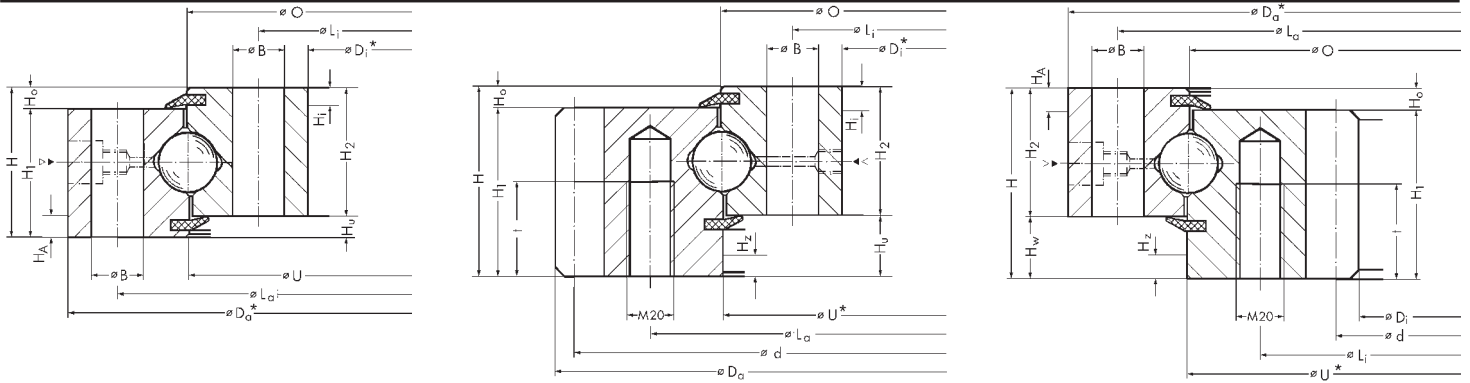

Static limiting load curves

—— Raceway - - - Bolts

Pilot height $H_1 = 10$ mm
 $H_A = 10$ mm
 $H_2 = 10$ mm

Pilot height of companion structure
= $H_1 - 1$ mm
= $H_A - 1$ mm
= $H_2 - 1$ mm

- ▶ $n_1 = 4$ equispaced conical grease nipple AM 10 x 1 DIN 71412 countersunk, when they are fitted on the outer bearing diameter
- △ = Filler plug

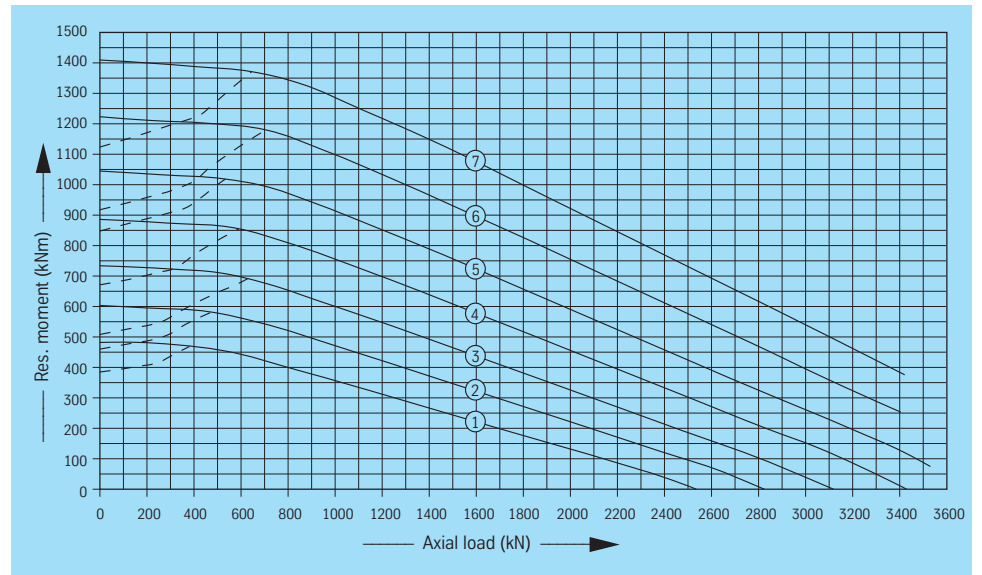

Service life curves · 30,000 revolutions

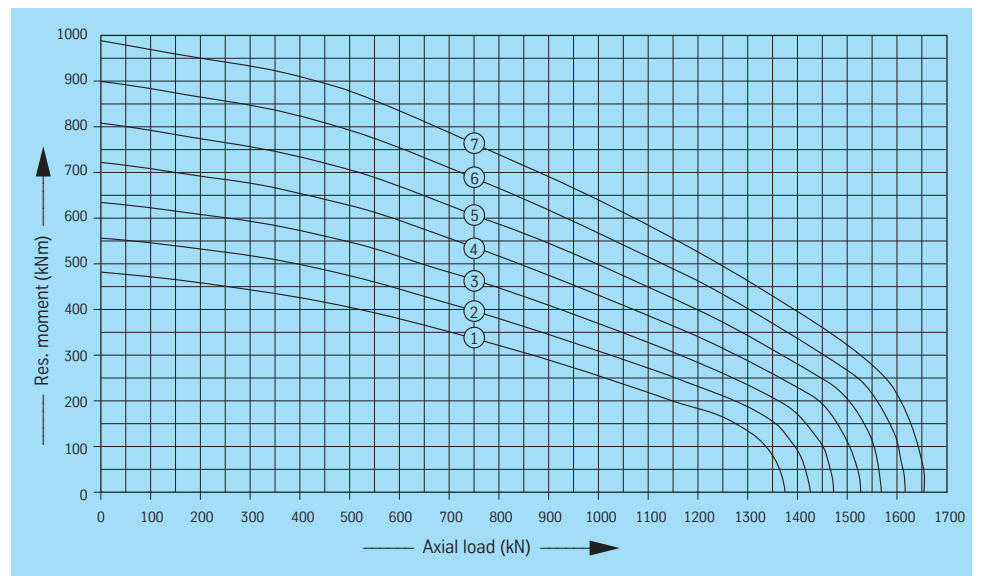

Standard series KD 600



Rothe Erde
Slew Bearings

Bearings with external gear

Drawing No. Ball track dia. D_L [mm]	Weight [kg]	Outer diameter (O.D.) D_o [mm]	Inner diameter (I.D.) D_i [mm]	Overall height H [mm]	External bolt circle dia. L_e [mm]	Internal bolt circle dia. L_i [mm]	Number of bolt holes per hole circle n	Bolt hole diameter B [mm]	Bolt size M [mm]	Number of grease nipples n_1	Diameter O [mm]	Diameter U [mm]	Ring height H_1 [mm]	Ring height H_2 [mm]	Distance at bottom Outer ring/inner ring H_b [mm]	Distance at top Outer ring/inner ring H_o [mm]	Gear P.C.D. d [mm]	Module m [mm]	Number of teeth z	Addendum modification sign per DIN 3960 October, 1976 $x \cdot m$ [mm]	Addendum reduction $k \cdot m$ [mm]	Tooth width b [mm]	Permissible tangential forces, normal [kN]	Permissible tangential forces, maximum [kN]	Curves
061.25.0764.103.11.1504 061.25.0764.106.21.1504	98	862,8	670	82	800	706	24	17,5	16	4	765	763	65	61	21	17	852	6	142	+0,0	-0,6	56	17,45 26,88	34,90 53,76	①
061.25.0980.107.11.1504 061.25.0980.108.21.1504	123	1078,4	886	79	1015	922	30	17,5	16	5	981	979	67	58	21	12	1064	8	133	+0,0	-0,8	62	25,80 39,68	51,60 79,36	②

Gear normalized

Gear quenched and tempered

Static limiting load curves

—— Raceway - - - Bolts

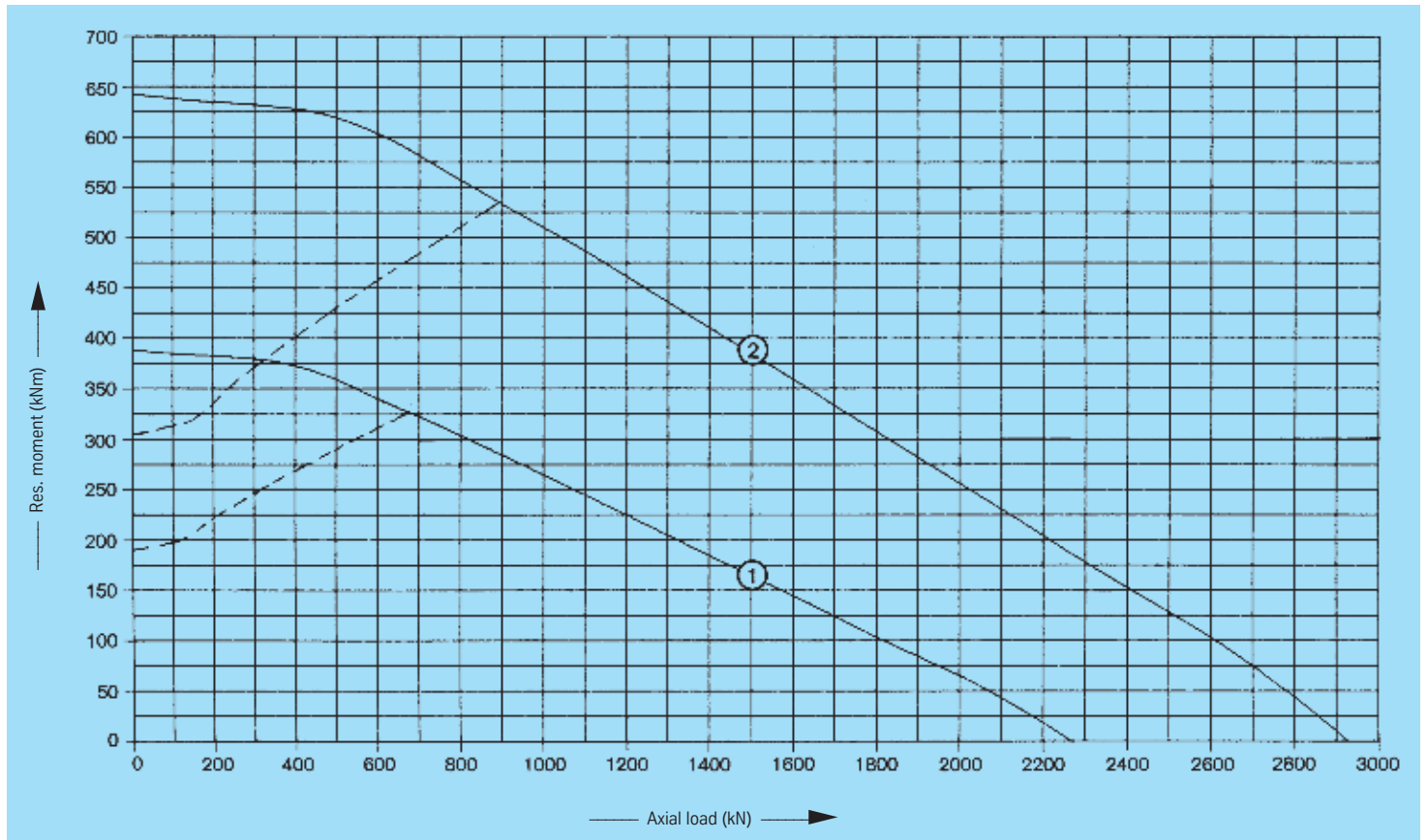

Standard series KD 600



Rothe Erde
Slewing Bearings

Thread depth t [mm]	Tooth neck dia. Z_u [mm]	Tooth neck height h_u [mm]
24	833	9
24	1042	5

Curves

①

②

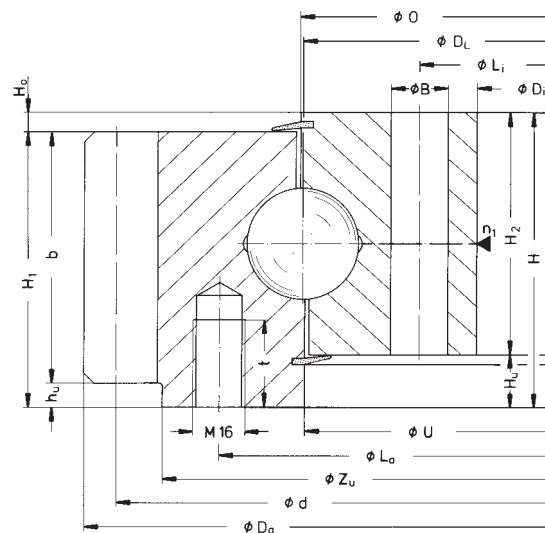

Service life curves · 30,000 revolutions

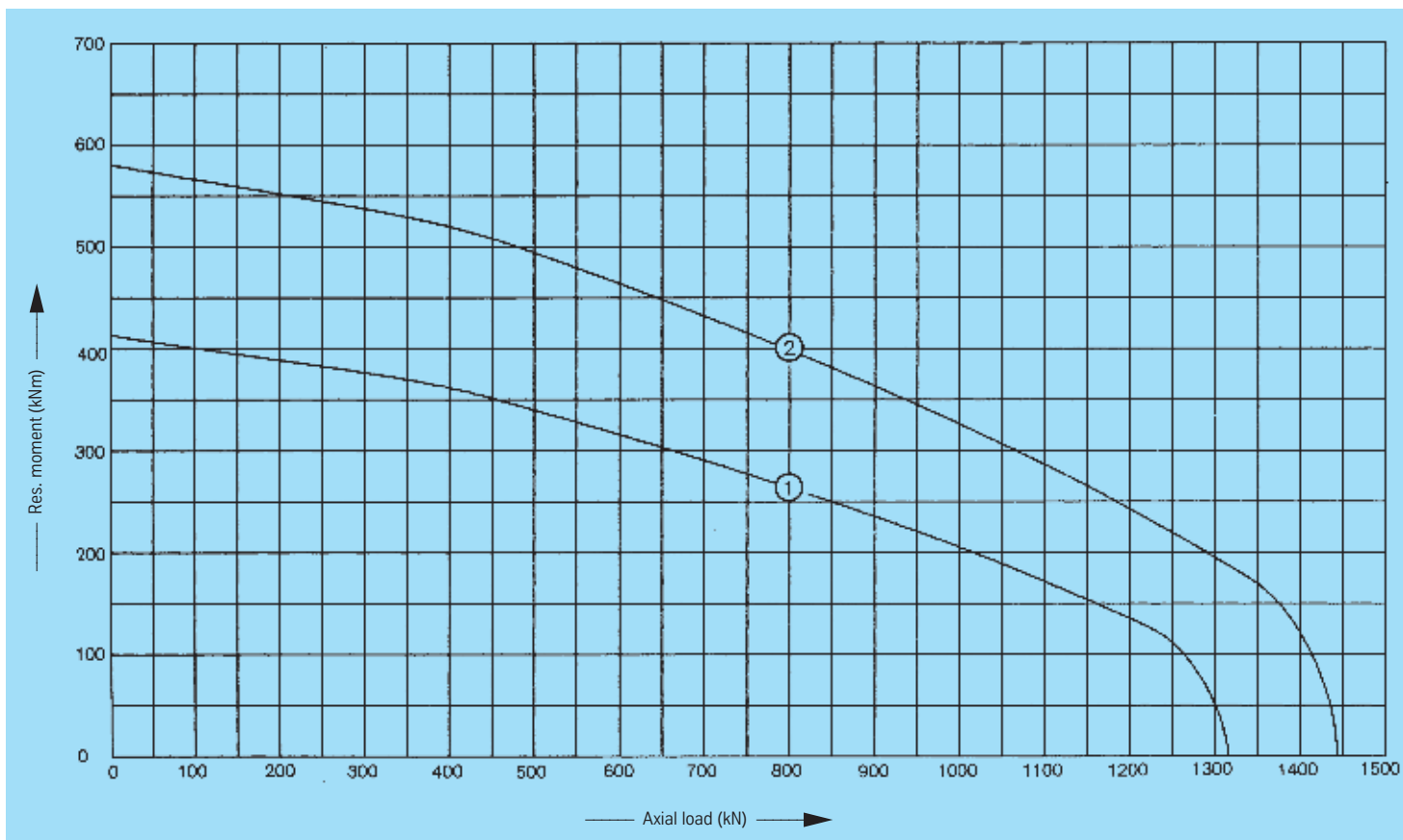

Standard series KD 600



Rothe Erde
Slew Bearings

Bearings with external gear

Drawing No. Ball track dia. D_L [mm]	Weight [kg]	Outer diameter (O.D.) D_o [mm]	Inner diameter (I.D.) D_i [mm]	Overall height H [mm]	External bolt circle dia. L_e [mm]	Internal bolt circle dia. L_i [mm]	Number of bolt holes per hole circle n	Bolt hole diameter B [mm]	Bolt size M [mm]	Number of grease nipples n_1	Diameter O [mm]	Diameter U [mm]	Ring height H_1 [mm]	Ring height H_2 [mm]	Distance at bottom Outer ring/inner ring H_b [mm]	Distance at top Outer ring/inner ring H_o [mm]	Gear P.C.D. d [mm]	Module m [mm]	Number of teeth z	Addendum modification sign per DIN 3960 October, 1976 $x \cdot m$ [mm]	Addendum reduction $k \cdot m$ [mm]	Tooth width b [mm]	Permissible tangential forces, normal [kN]	Permissible tangential forces, maximum [kN]	Curves
061.20.0400.100.11.1503 061.20.0400.101.21.1503	35	499	325	55	448	352	16	13,5	12	2	401	399	46	46	9	9	485	5	97	+2,5	-0,5	46	14,44	28,88	③
061.20.0450.100.11.1503 061.20.0450.101.21.1503	39	554	369	55	500	400	16	15,5	14	2	451	449	46	46	9	9	540	5	108	+2,5	-0,5	46	14,44	28,88	④
061.20.0560.100.11.1503 061.20.0560.101.21.1503	53	670,8	479	55	610	510	20	15,5	14	4	561	559	46	46	9	9	654	6	109	+3,0	-0,6	46	17,33	34,66	⑤
061.20.0630.100.11.1503 061.20.0630.101.21.1503	61	742,8	543	55	682	578	20	17,5	16	4	631	629	46	46	9	9	726	6	121	+3,0	-0,6	46	17,33	34,66	⑥
061.20.0710.100.11.1503 061.20.0710.101.21.1503	67	820,8	623	55	762	658	24	17,5	16	4	711	709	46	46	9	9	804	6	134	+3,0	-0,6	46	17,33	34,66	⑦

Gear normalized

Gear quenched and tempered

Static limiting load curves

—— Raceway - - - Bolts

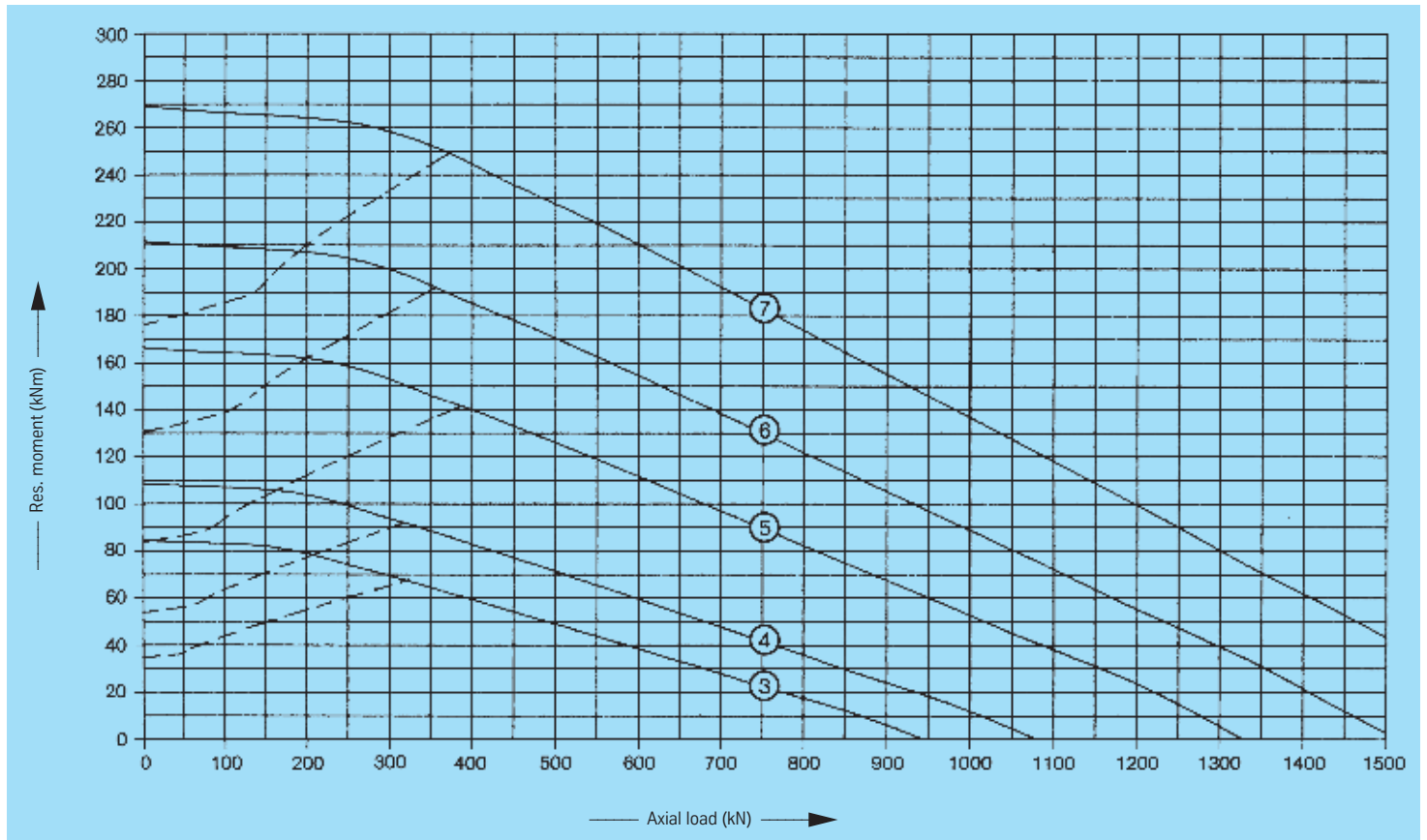

Standard series KD 600



Rothe Erde
Slewing Bearings

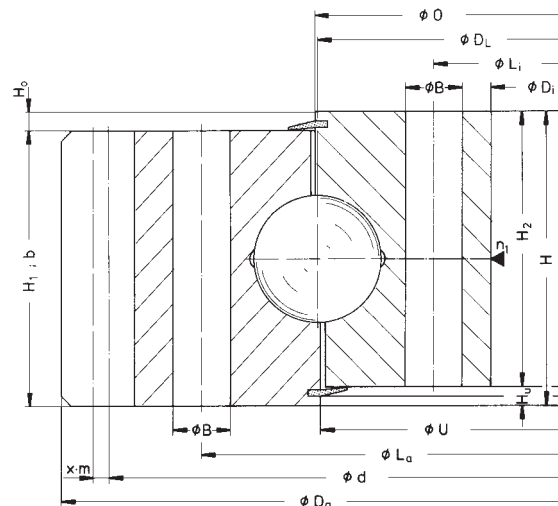

Service life curves · 30,000 revolutions

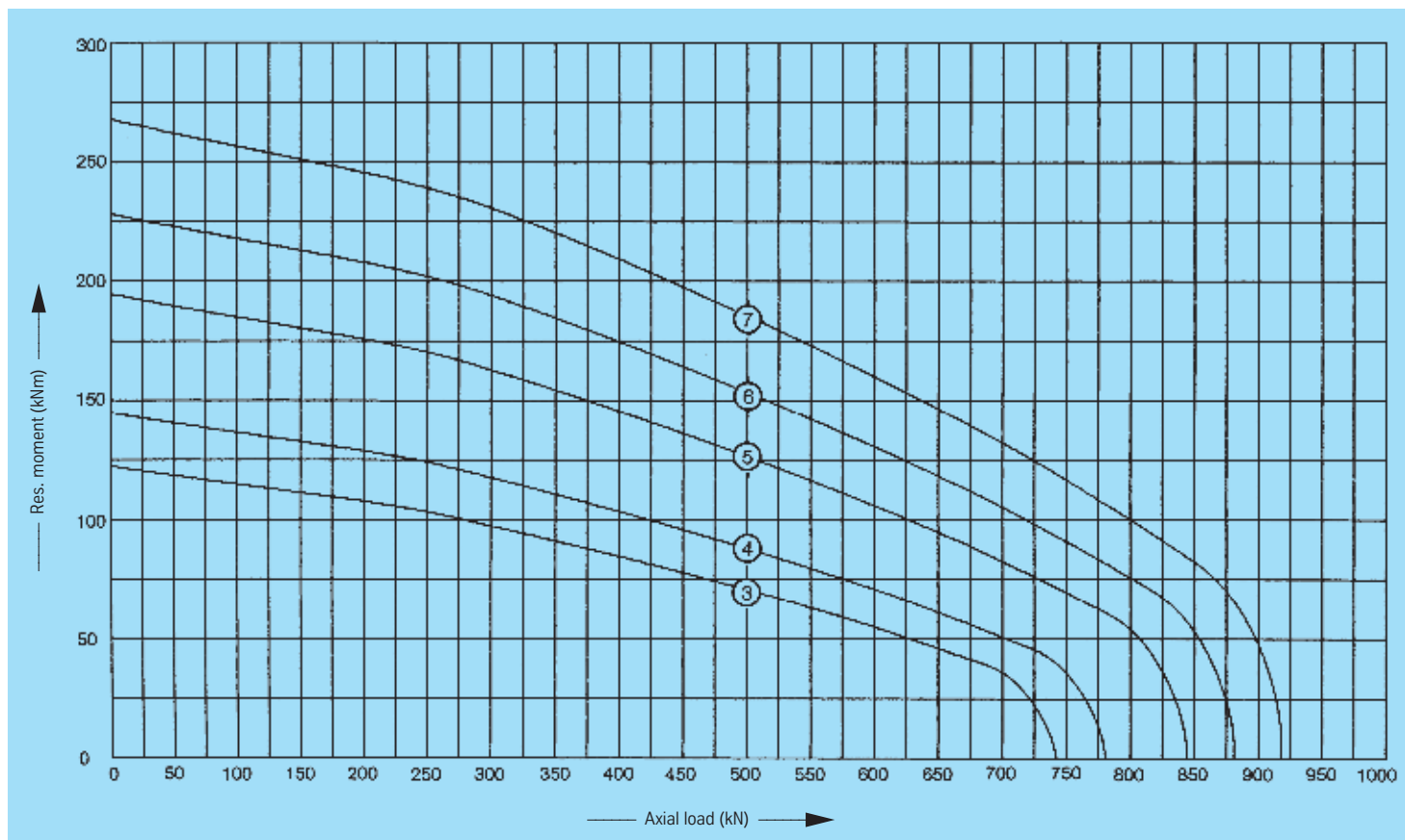

Standard series KD 600



Rothe Erde
Slew Bearings

Bearings with external gear

Drawing No. Ball track dia. D_L [mm]	Weight [kg]	Outer diameter (O.D.) D_o [mm]	Inner diameter (I.D.) D_i [mm]	Overall height H [mm]	External bolt circle dia. L_e [mm]	Internal bolt circle dia. L_i [mm]	Number of bolt holes per hole circle n	Bolt hole diameter B [mm]	Bolt size M [mm]	Number of grease nipples n_1	Diameter O [mm]	Diameter U [mm]	Ring height H_1 [mm]	Ring height H_2 [mm]	Distance at bottom Outer ring/inner ring H_b [mm]	Distance at top Outer ring/inner ring H_o [mm]	Gear P.C.D. d [mm]	Module m [mm]	Number of teeth z	Addendum modification sign per DIN 3960 October, 1976 $x \cdot m$ [mm]	Addendum reduction $k \cdot m$ [mm]	Tooth width b [mm]	Permissible tangential forces, normal [kN]	Permissible tangential forces, maximum [kN]	Curves
061.25.0764.600.11.1503 061.25.0764.601.21.1503	95	886,8	671	63	823	706	24	17,5	16	4	765	763	54	54	9	9	870	6	145	+3,0	-0,6	54	20,35 31,30	40,70 62,60	⑧
061.25.0980.890.11.1503 061.25.0980.891.21.1503	124	1110,4	887	63	1039	922	30	17,5	16	5	981	979	54	54	9	9	1088	8	136	+4,0	-0,8	54	27,13 41,74	54,26 83,48	⑨
061.25.1120.000.11.1504 061.25.1120.001.21.1504	182	1278	1013	79	1183	1057	30	22	20	5	1121	1119	70	54	25	9	1250	10	125	+5,0	-1,0	70	43,95 67,63	87,90 135,26	⑩
061.25.1250.100.11.1504 061.25.1250.101.21.1504	221	1408	1143	79	1313	1187	36	22	20	6	1251	1249	70	54	25	9	1380	10	138	+5,0	-1,0	70	43,95 67,63	87,90 135,26	⑪

Gear normalized
Gear quenched and tempered

Static limiting load curves

—— Raceway - - - Bolts

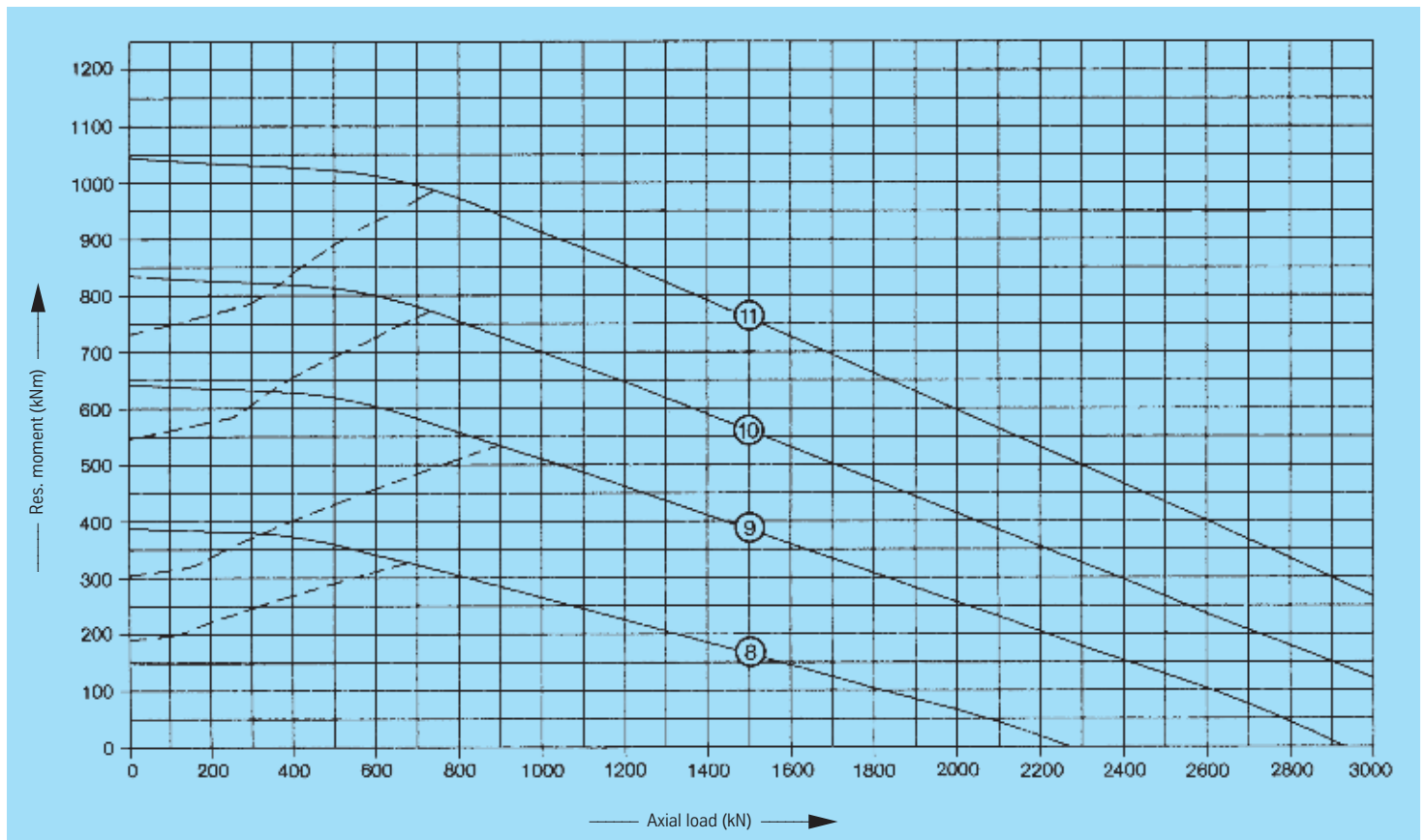

Standard series KD 600



Rothe Erde
Slewing Bearings

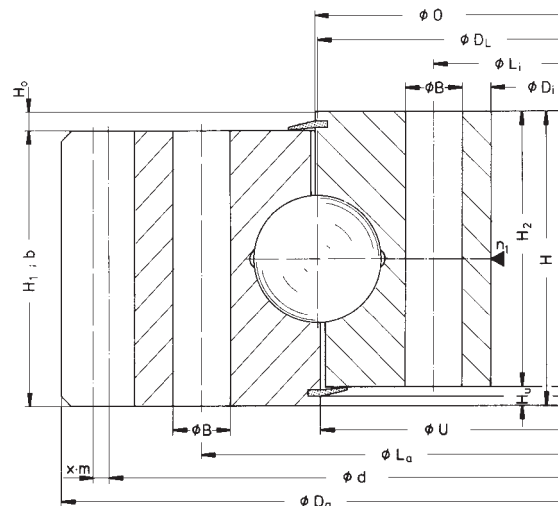

Service life curves · 30,000 revolutions

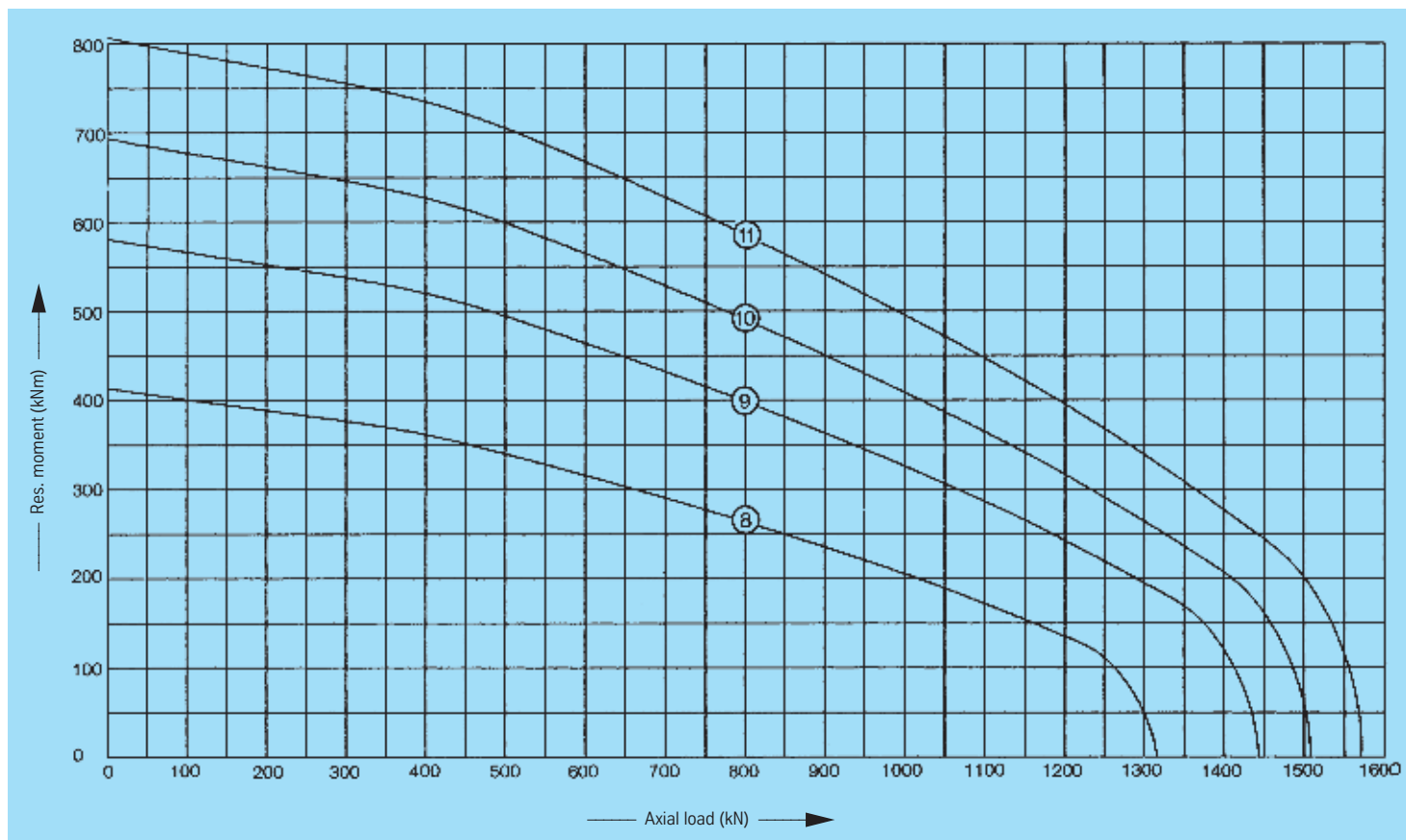

Standard series KD 600



Rothe Erde
Slew Bearings

Bearings with external gear

Drawing No. Ball track dia. D_t [mm]	Weight [kg]	Outer diameter (O.D.) D_o [mm]	Inner diameter (I.D.) D_i [mm]	Overall height H [mm]	External bolt circle dia. L_e [mm]	Internal bolt circle dia. L_i [mm]	Number of bolt holes per hole circle n	Bolt hole diameter B [mm]	Bolt size M [mm]	Number of grease nipples n_1	Diameter O [mm]	Diameter U [mm]	Ring height H_1 [mm]	Ring height H_2 [mm]	Distance at bottom Outer ring/inner ring H_b [mm]	Distance at top Outer ring/inner ring H_o [mm]	Gear P.C.D. d [mm]	Module m [mm]	Number of teeth z	Addendum modification sign per DIN 3960 October, 1976 $x \cdot m$ [mm]	Addendum reduction $k \cdot m$ [mm]	Tooth width b [mm]	Permissible tangential forces, normal [kN]	Permissible tangential forces, maximum [kN]	Curves
061.30.1180.000.11.1504 061.30.1180.001.21.1504	227	1338	1068	79	1248	1112	36	22	20	6	1181	1178	70	63	16	9	1310	10	131	+5,0	-1,0	70	43,95 64,25	87,90 128,50	12
061.30.1320.000.11.1504 061.30.1320.001.21.1504	298	1497,6	1208	89	1388	1252	42	22	20	6	1321	1318	80	63	26	9	1464	12	122	+6,0	-1,2	80	60,30 88,10	120,60 176,20	13
061.30.1500.200.11.1504 061.30.1500.201.21.1523	338	1677,6	1388	89	1568	1432	48	22	20	6	1501	1498	80	63	26	9	1644	12	137	+6,0	-1,2	80	60,30 88,10	120,60 176,20	14

Gear normalized

Gear quenched and tempered

Static limiting load curves

—— Raceway - - - Bolts

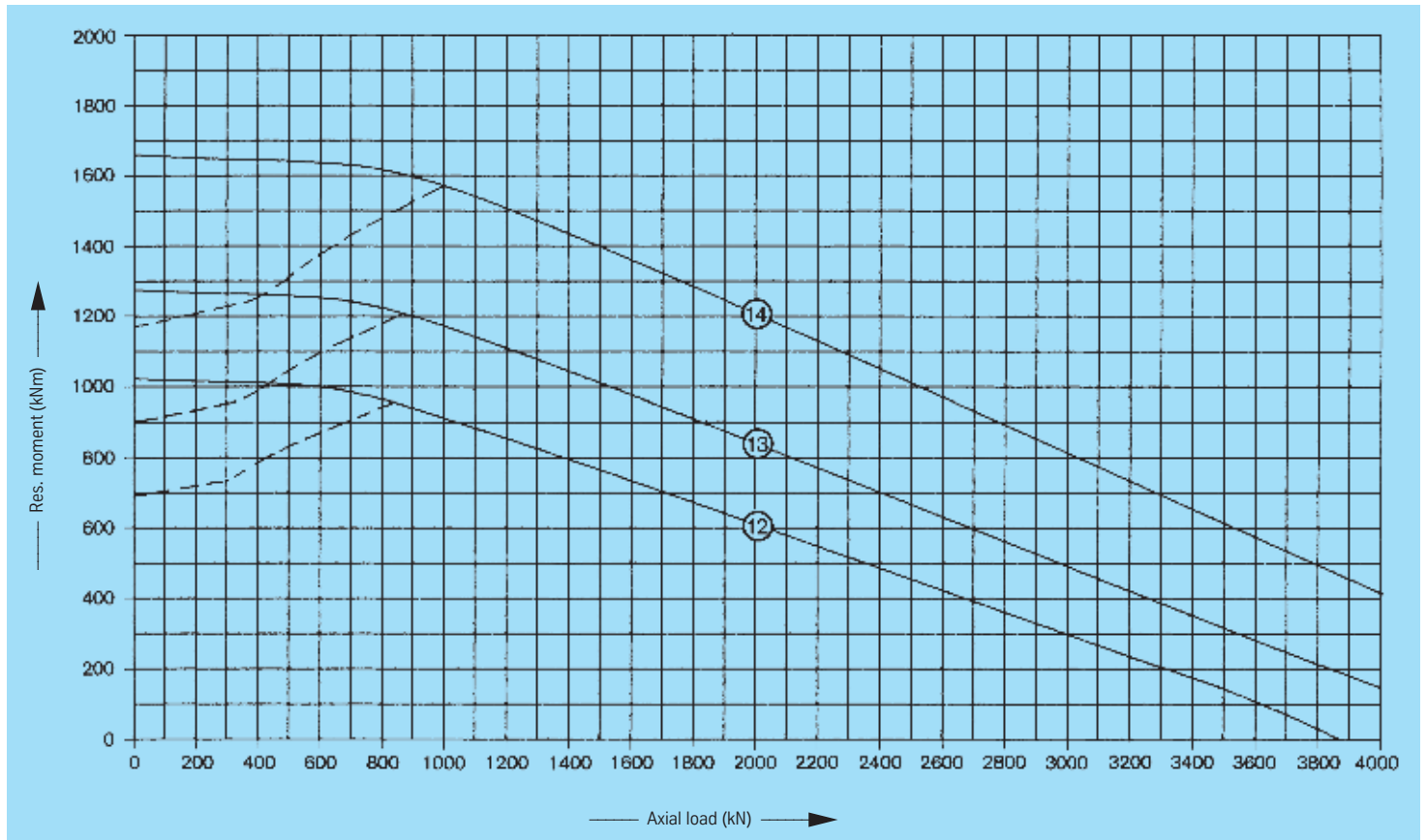

Standard series KD 600



Rothe Erde
Slewing Bearings

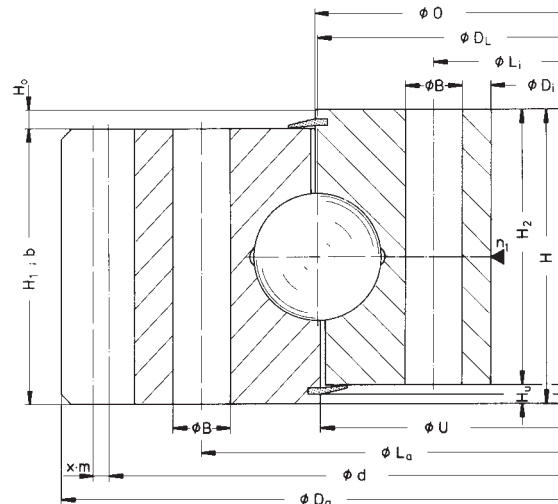

Service life curves · 30,000 revolutions

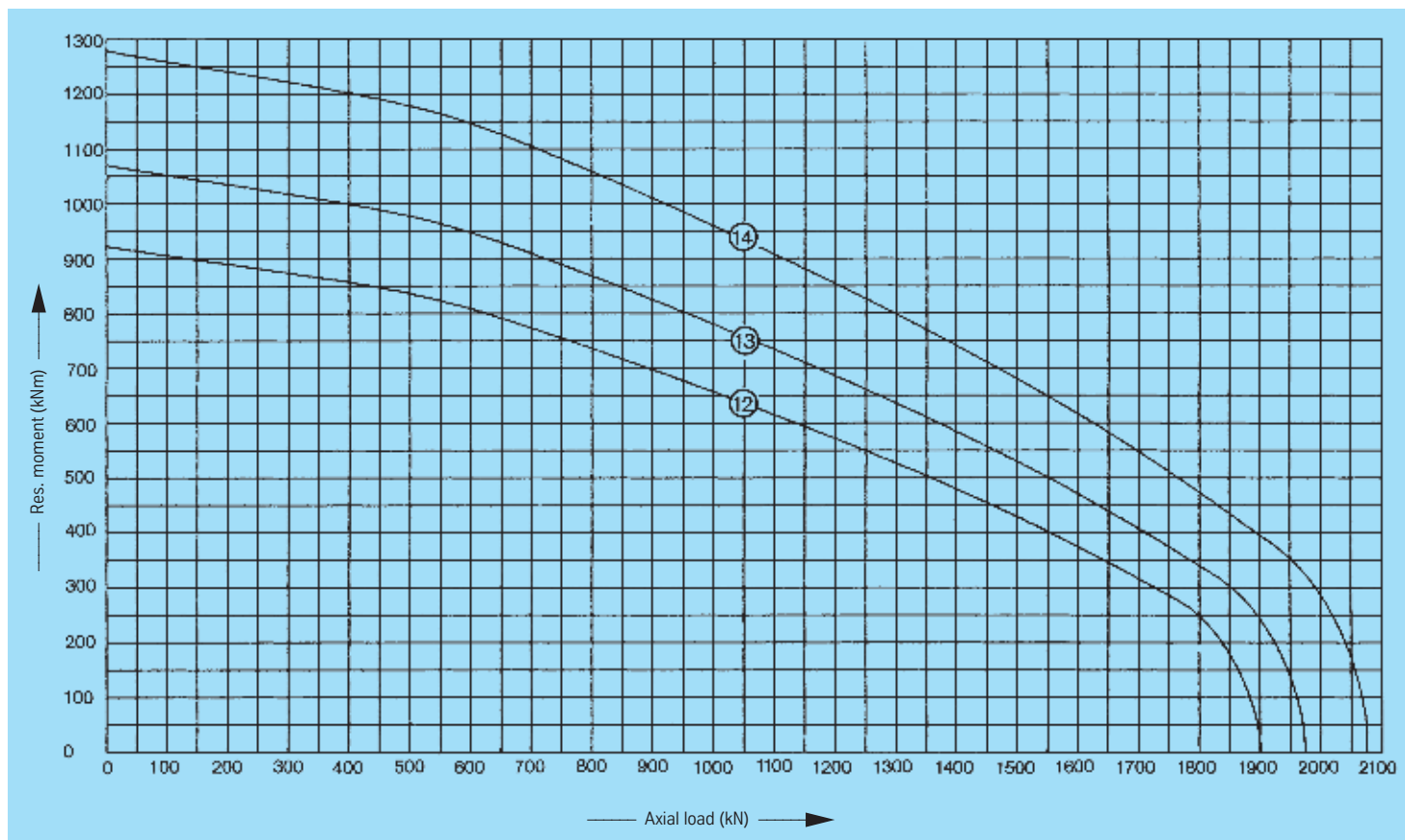

Standard series KD 600



Rothe Erde
Slew Bearings

Bearings with external gear

Drawing No. Ball track dia. D_L [mm]	Weight [kg]	Outer diameter (O.D.) D_o [mm]	Inner diameter (I.D.) D_i [mm]	Overall height H [mm]	External bolt circle dia. L_e [mm]	Internal bolt circle dia. L_i [mm]	Number of bolt holes per hole circle n	Bolt hole diameter B [mm]	Bolt size M [mm]	Number of grease nipples n_1	Diameter O [mm]	Diameter U [mm]	Ring height H_1 [mm]	Ring height H_2 [mm]	Distance at bottom Outer ring/inner ring H_b [mm]	Distance at top Outer ring/inner ring H_o [mm]	Gear P.C.D. d [mm]	Module m [mm]	Number of teeth z	Addendum modification sign per DIN 3960 October, 1976 $x \cdot m$ [mm]	Addendum reduction $k \cdot m$ [mm]	Tooth width b [mm]	Permissible tangential forces, normal [kN]	Permissible tangential forces, maximum [kN]	Curves
061.40.1400.000.19.1504 061.40.1400.001.29.1504	404	1593,6	1266	94	1482	1318	36	26	24	6	1401	1398	85	81	13	9	1560	12	130	+6,0	-1,2	85	64,05	128,1	15
061.40.1600.008.19.1503 061.40.1600.009.29.1503	479	1803,2	1466	94	1682	1518	40	26	24	8	1601	1598	85	81	13	9	1764	14	126	+7,0	-1,4	85	74,7	149,4	16
061.40.1800.013.19.1503 061.40.1800.014.29.1503	531	1999,2	1666	94	1882	1718	44	26	24	11	1801	1798	85	81	13	9	1960	14	140	+7,0	-1,4	85	74,7	149,4	17

Gear normalized

Gear quenched and tempered

Static limiting load curves

—— Raceway

- - - Bolts

—— Bolts

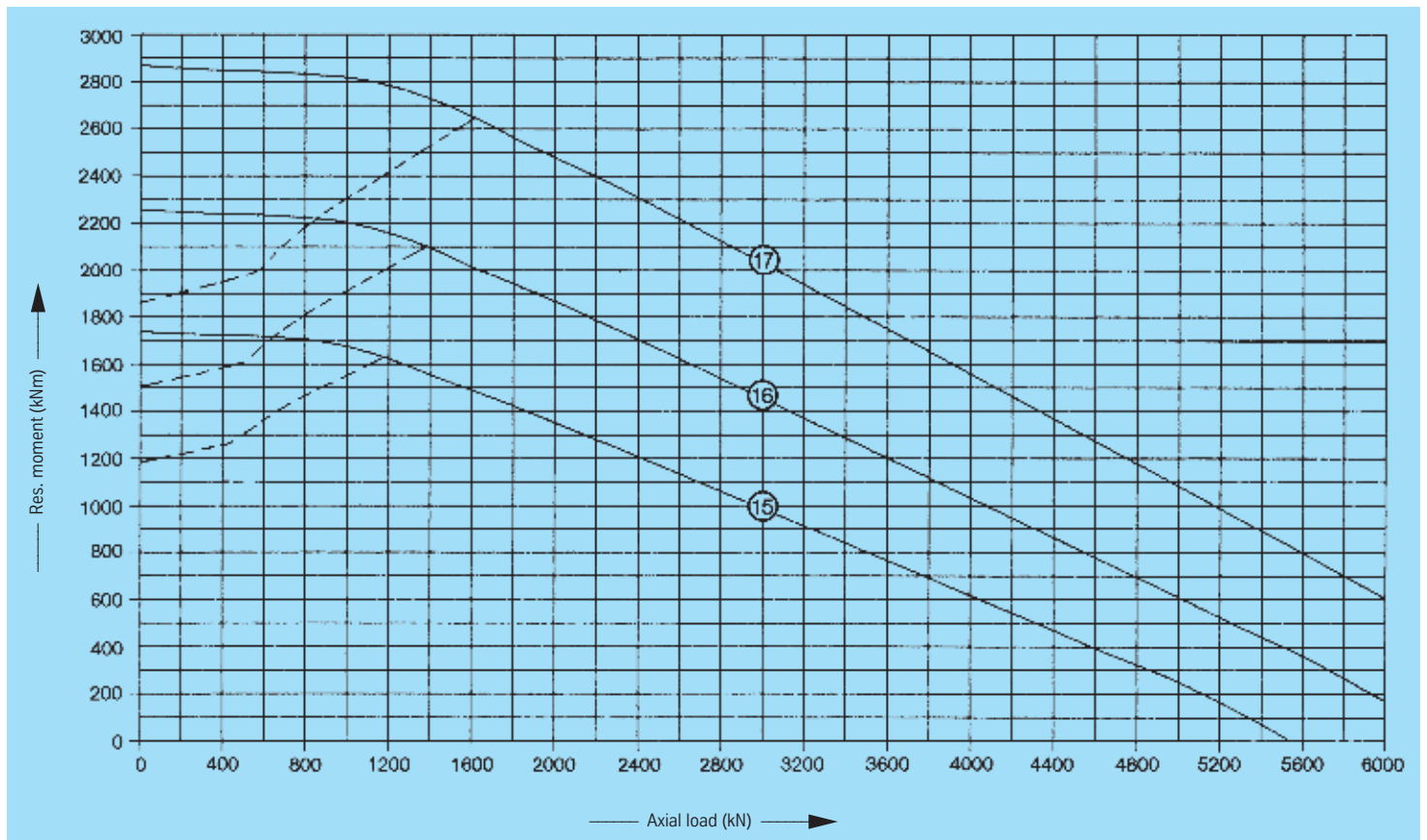

Standard series KD 600



Rothe Erde
Slewing Bearings

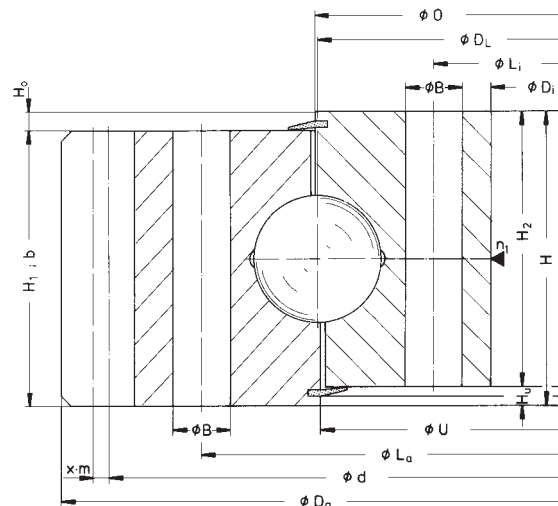

Service life curves · 30,000 revolutions

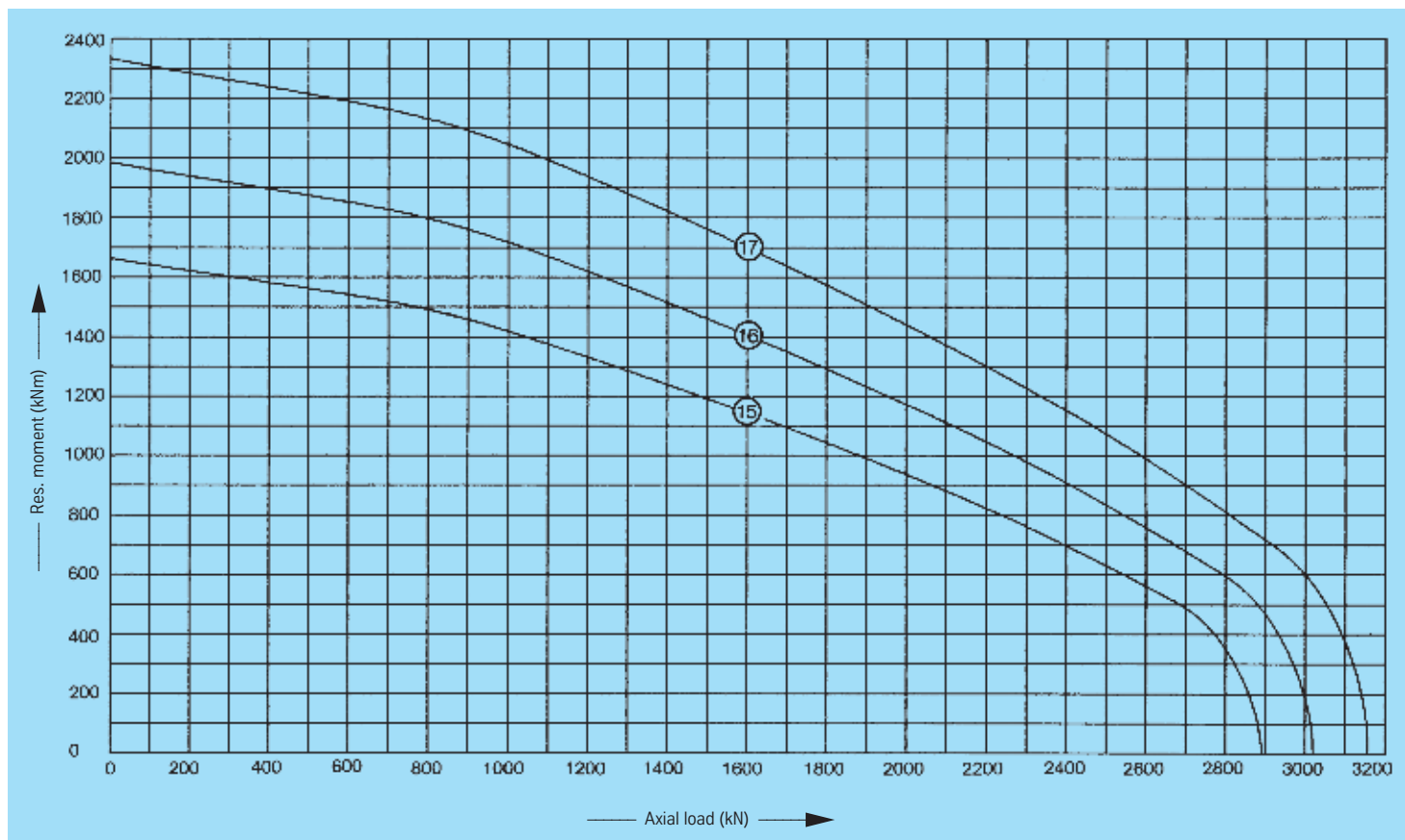

Standard series KD 600



Rothe Erde
Slewing Bearings

Bearings with external gear

Drawing No. Ball track dia. D_L [mm]	Weight [kg]	Outer diameter (O.D.) D_o [mm]	Inner diameter (I.D.) D_i [mm]	Overall height H [mm]	External bolt circle dia. L_e [mm]	Internal bolt circle dia. L_i [mm]	Number of bolt holes per hole circle n	Bolt hole diameter B [mm]	Bolt size M [mm]	Number of grease nipples n_1	Diameter O [mm]	Diameter U [mm]	Ring height H_1 [mm]	Ring height H_2 [mm]	Distance at bottom Outer ring/inner ring H_b [mm]	Distance at top Outer ring/inner ring H_o [mm]	Gear P.C.D. d [mm]	Module m [mm]	Number of teeth z	Addendum modification sign per DIN 3960 October, 1976 $x \cdot m$ [mm]	Addendum reduction $k \cdot m$ [mm]	Tooth width b [mm]	Permissible tangential forces, normal [kN]	Permissible tangential forces, maximum [kN]	Curves
061.50.1900.001.49.1504	820	2139,2	1729	109	2005	1795	36	33	30	9	1902	1898	100	99	10	9	2100	14	150	+7,0	-1,4	100	128,5	257,0	18
061.50.2130.001.49.1504	931	2380,8	1959	109	2235	2025	48	33	30	8	2132	2128	100	99	10	9	2336	16	146	+8,0	-1,6	100	146,8	293,6	19
061.50.2355.001.49.1504	1024	2604,8	2184	109	2460	2250	54	33	30	9	2357	2353	100	99	10	9	2560	16	160	+8,0	-1,6	100	146,8	293,6	20
061.50.2645.001.49.1504	1142	2892,8	2474	109	2750	2540	60	33	30	12	2647	2643	100	99	10	9	2848	16	178	+8,0	-1,6	100	146,8	293,6	21

Bearing rings quenched and tempered

Static limiting load curves

—— Raceway - - - Bolts

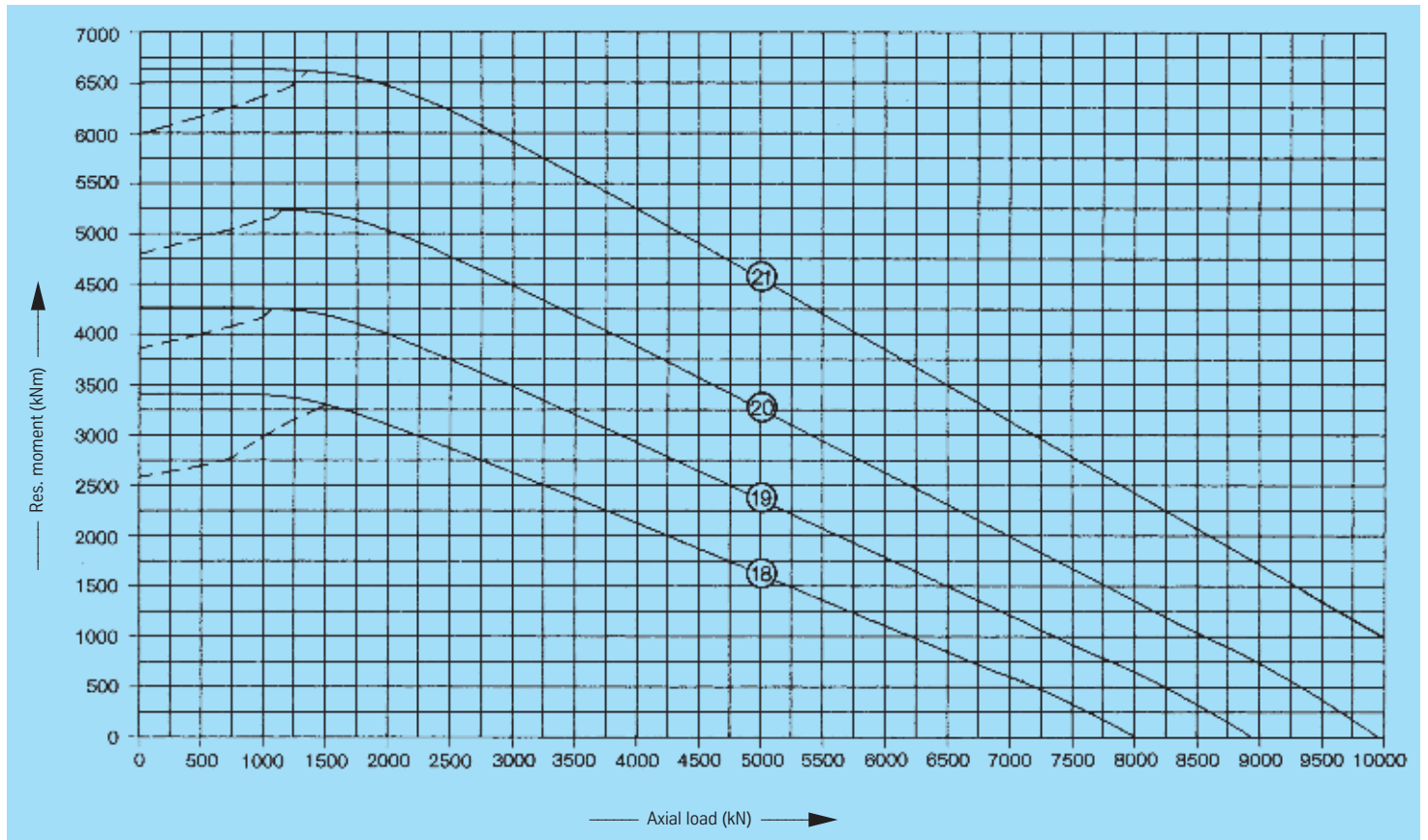

Standard series KD 600



Rothe Erde
Slewing Bearings

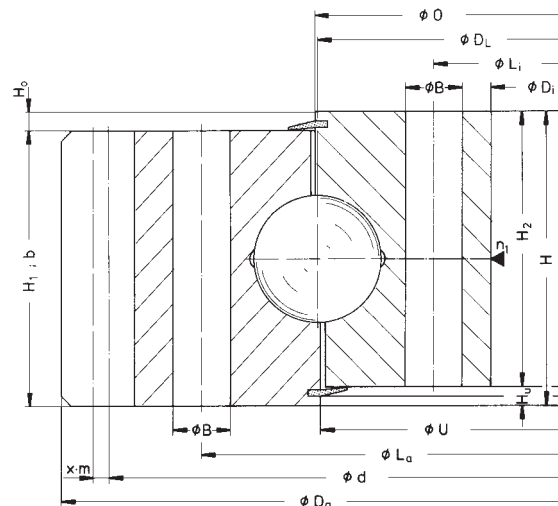

Service life curves · 30,000 revolutions

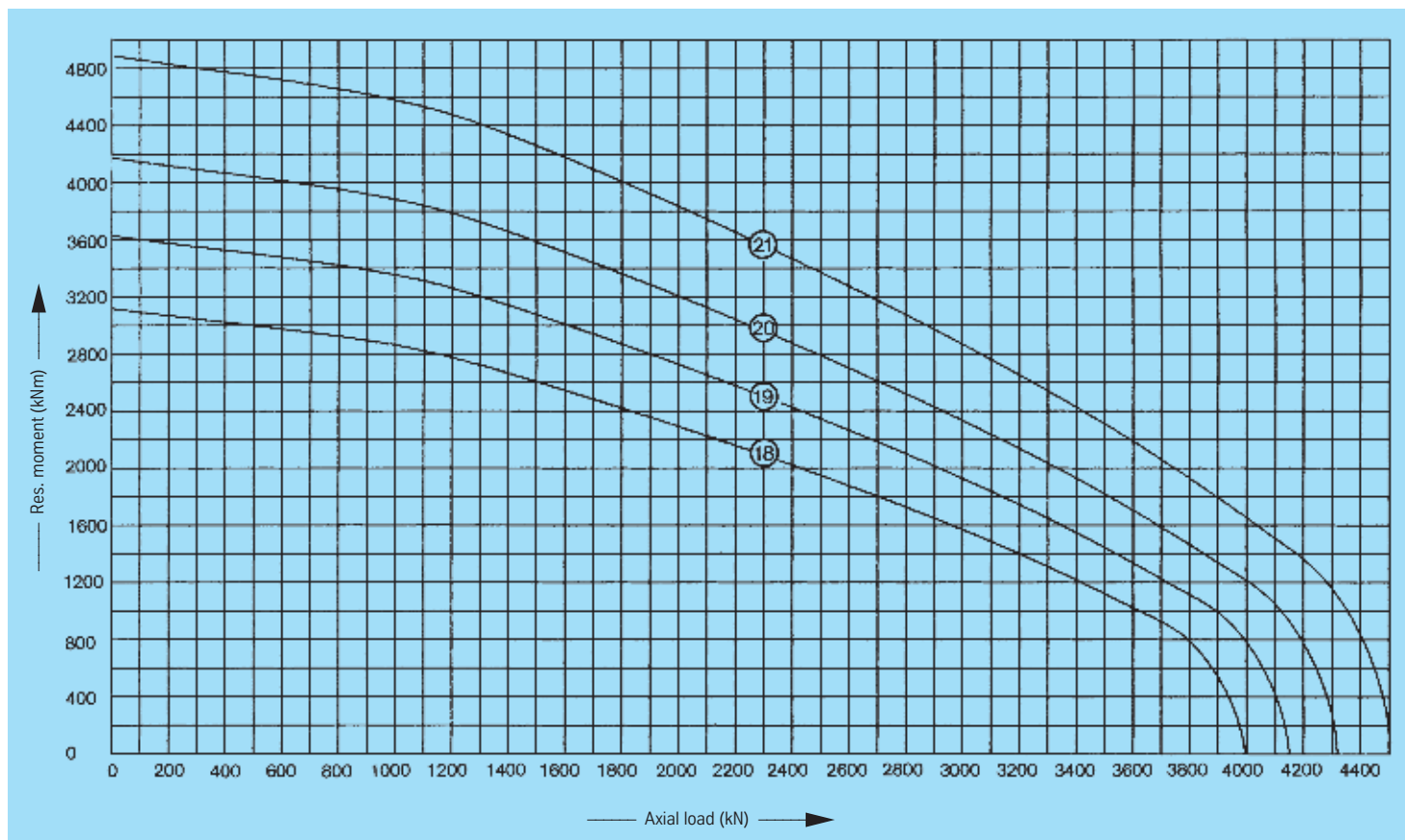

Standard series KD 600



Rothe Erde
Slewing Bearings

Bearings with internal gear

Drawing No. Ball track dia. D_1 [mm]	Weight [kg]	Outer diameter (O.D.) D_o [mm]	Inner diameter (I.D.) D_i [mm]	Overall height H [mm]	External bolt circle dia. L_e [mm]	Internal bolt circle dia. L_i [mm]	Number of bolt holes per hole circle n	Bolt hole diameter B [mm]	Bolt size M [mm]	Number of grease nipples n_1	Diameter O [mm]	Diameter U [mm]	Ring height H_1 [mm]	Ring height H_2 [mm]	Distance at bottom Outer ring/inner ring H_b [mm]	Distance at top Outer ring/inner ring H_o [mm]	Gear P.C.D. d [mm]	Module m [mm]	Number of teeth z	Addendum modification sign per DIN 3960 October, 1976 $x \cdot m$ [mm]	Addendum reduction $k \cdot m$ [mm]	Tooth width b [mm]	Permissible tangential forces, normal [kN]	Permissible tangential forces, maximum [kN]	Curves
062.25.0886.106.11.1504 062.25.0886.109.21.1504	109	980	784	77	944	850	36	17,5	16	6	885	887	67	56	21	10	800	8	100	-0	-	62	28,00 43,13	56,00 86,26	22
062.25.1077.308.11.1504 062.25.1077.304.21.1504	148	1170	960	84	1134	1040	36	17,5	16	6	1076	1078	66	64	20	18	980	10	98	-0	-	61	34,60 53,15	69,20 106,3	23

Gear normalized

Gear quenched and tempered

Static limiting load curves

—— Raceway - - - Bolts

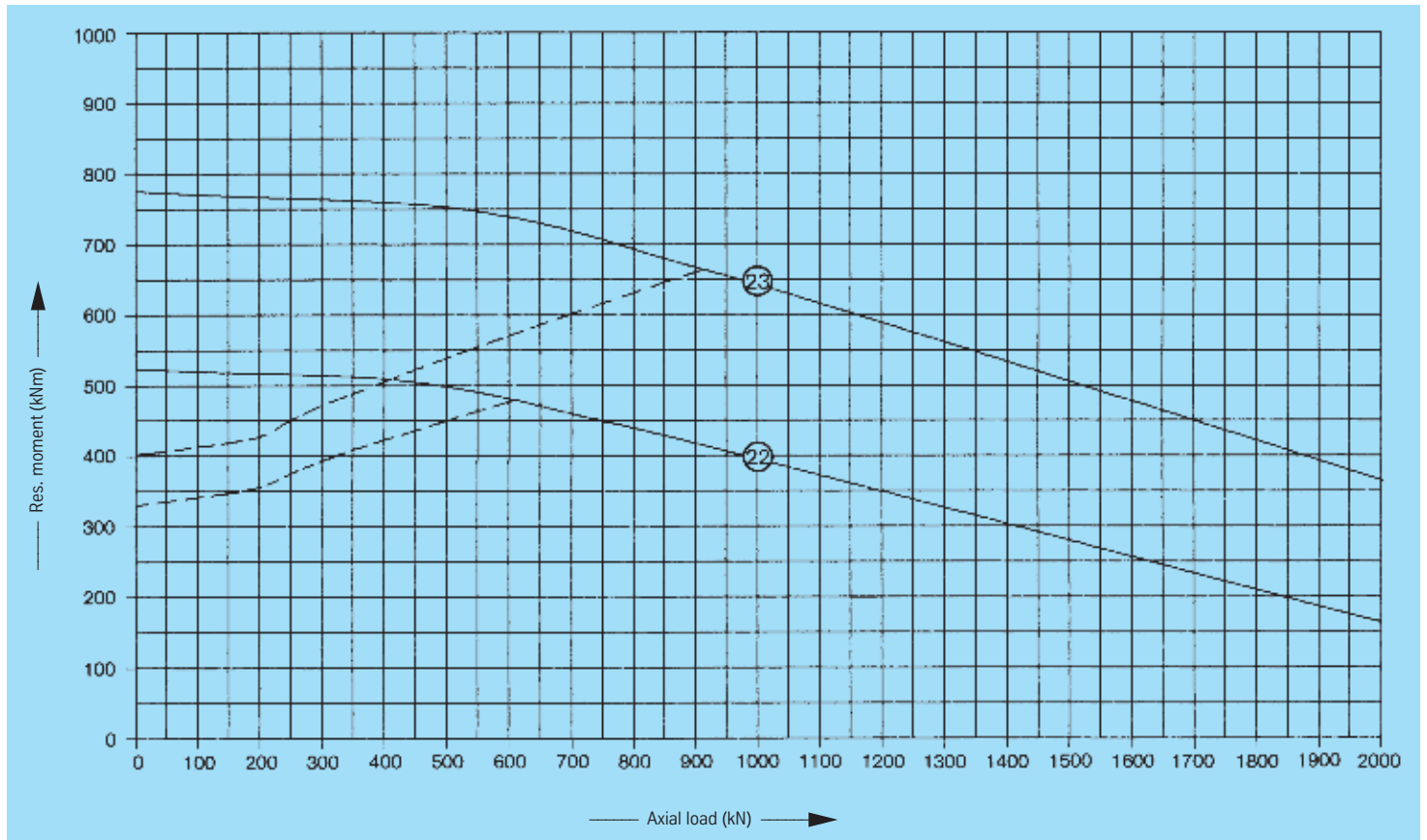

Standard series KD 600



Rothe Erde
Slewing Bearings

Thread depth t [mm]	Tooth neck dia. Z_u [mm]	Tooth neck height h_u [mm]
24	820	5
24	1010	5

Curves

22

23

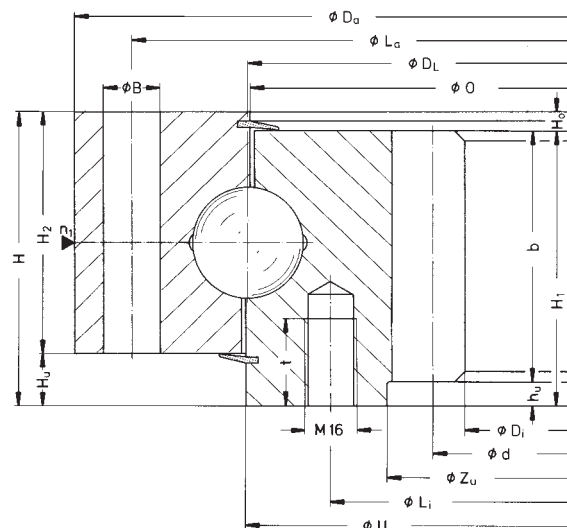

Service life curves · 30,000 revolutions

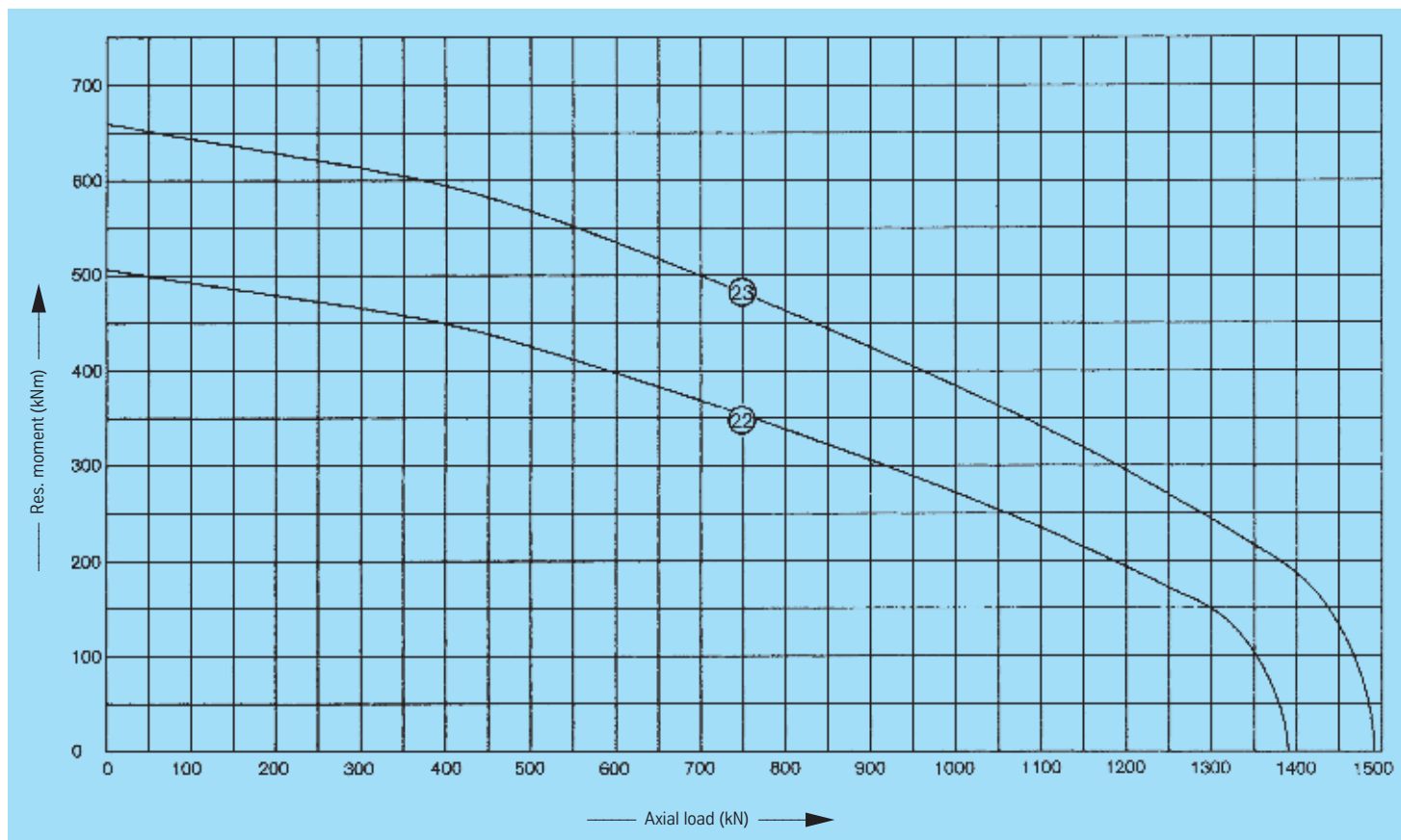

Standard series KD 600



Rothe Erde
Slew Bearings

Bearings with internal gear

Drawing No. Ball track dia. D_L [mm]	Weight [kg]	Outer diameter (O.D.) D_o [mm]	Inner diameter (I.D.) D_i [mm]	Overall height H [mm]	External bolt circle dia. L_e [mm]	Internal bolt circle dia. L_i [mm]	Number of bolt holes per hole circle n	Bolt hole diameter B [mm]	Bolt size M [mm]	Number of grease nipples n_1	Diameter O [mm]	Diameter U [mm]	Ring height H_1 [mm]	Ring height H_2 [mm]	Distance at bottom Outer ring/inner ring H_b [mm]	Distance at top Outer ring/inner ring H_o [mm]	Gear P.C.D. d [mm]	Module m [mm]	Number of teeth z	Addendum modification sign per DIN 3960 October, 1976 $x \cdot m$ [mm]	Addendum reduction $k \cdot m$ [mm]	Tooth width b [mm]	Permissible tangential forces, normal [kN]	Permissible tangential forces, maximum [kN]	Curves
062.20.0400.000.11.1503 062.20.0400.001.21.1503	33	475	300	55	448	352	16	13,5	12	2	399	401	46	46	9	9	305	5	61	-2,5	-	46	14,44	28,88	24
062.20.0450.000.11.1503 062.20.0450.001.21.1503	38	531	345	55	500	400	16	15,5	14	2	449	451	46	46	9	9	350	5	70	-2,5	-	46	14,44	28,88	25
062.20.0560.000.11.1503 062.20.0560.001.21.1503	51	641	450	55	610	510	20	15,5	14	4	559	561	46	46	9	9	456	6	76	-3,0	-	46	17,33	34,66	26
062.20.0630.000.11.1503 062.20.0630.001.21.1503	59	717	516	55	682	578	20	17,5	16	4	629	631	46	46	9	9	522	6	87	-3,0	-	46	17,33	34,66	27
062.20.0710.000.11.1503 062.20.0710.001.21.1503	68	797	594	55	762	658	24	17,5	16	4	709	711	46	46	9	9	600	6	100	-3,0	-	46	17,33	34,66	28

Gear normalized
Gear quenched and tempered

Static limiting load curves

—— Raceway - - - Bolts

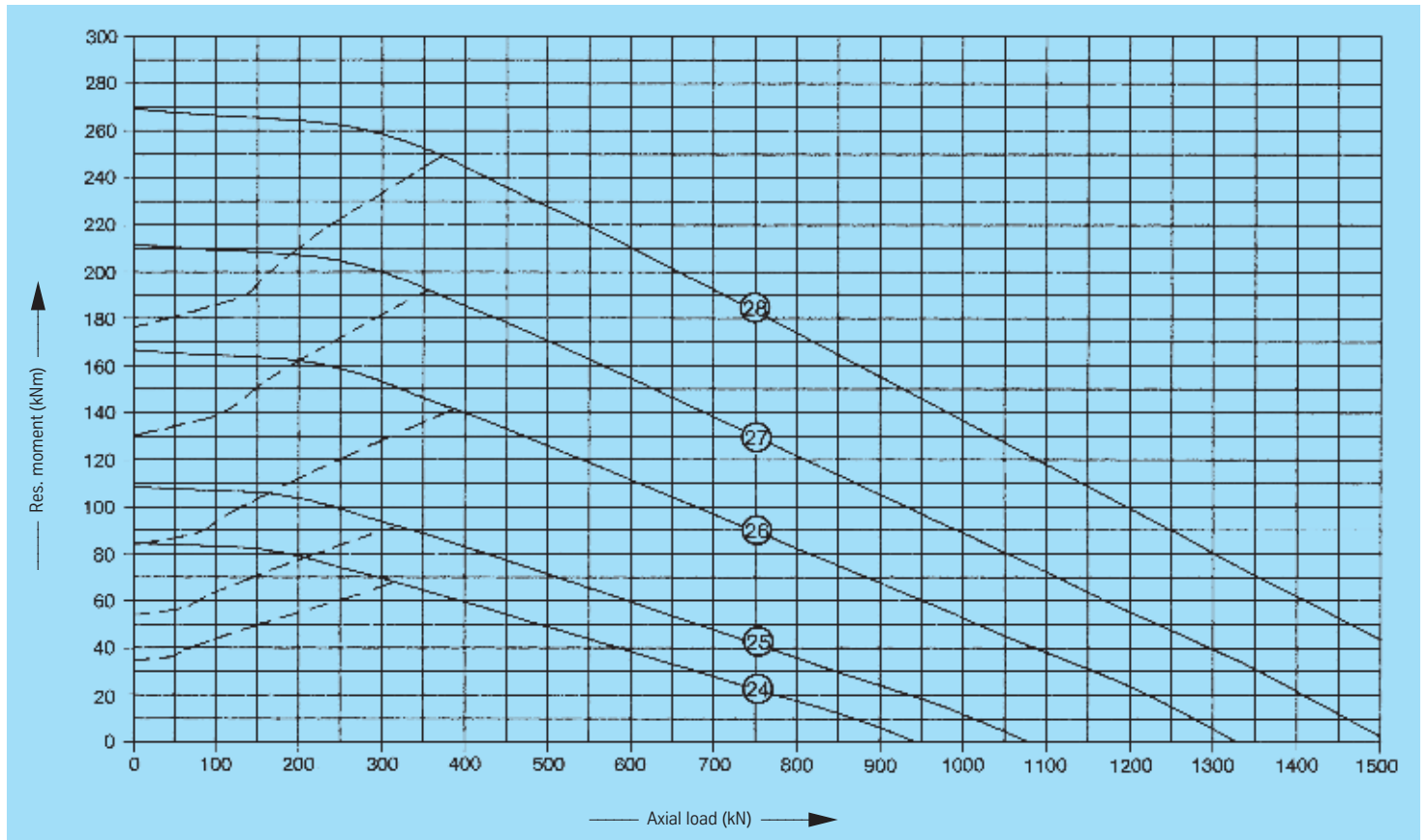

Standard series KD 600



Rothe Erde
Slewing Bearings

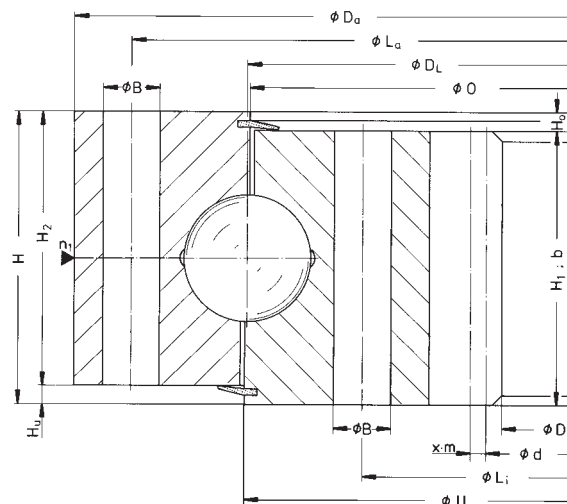

Service life curves · 30,000 revolutions

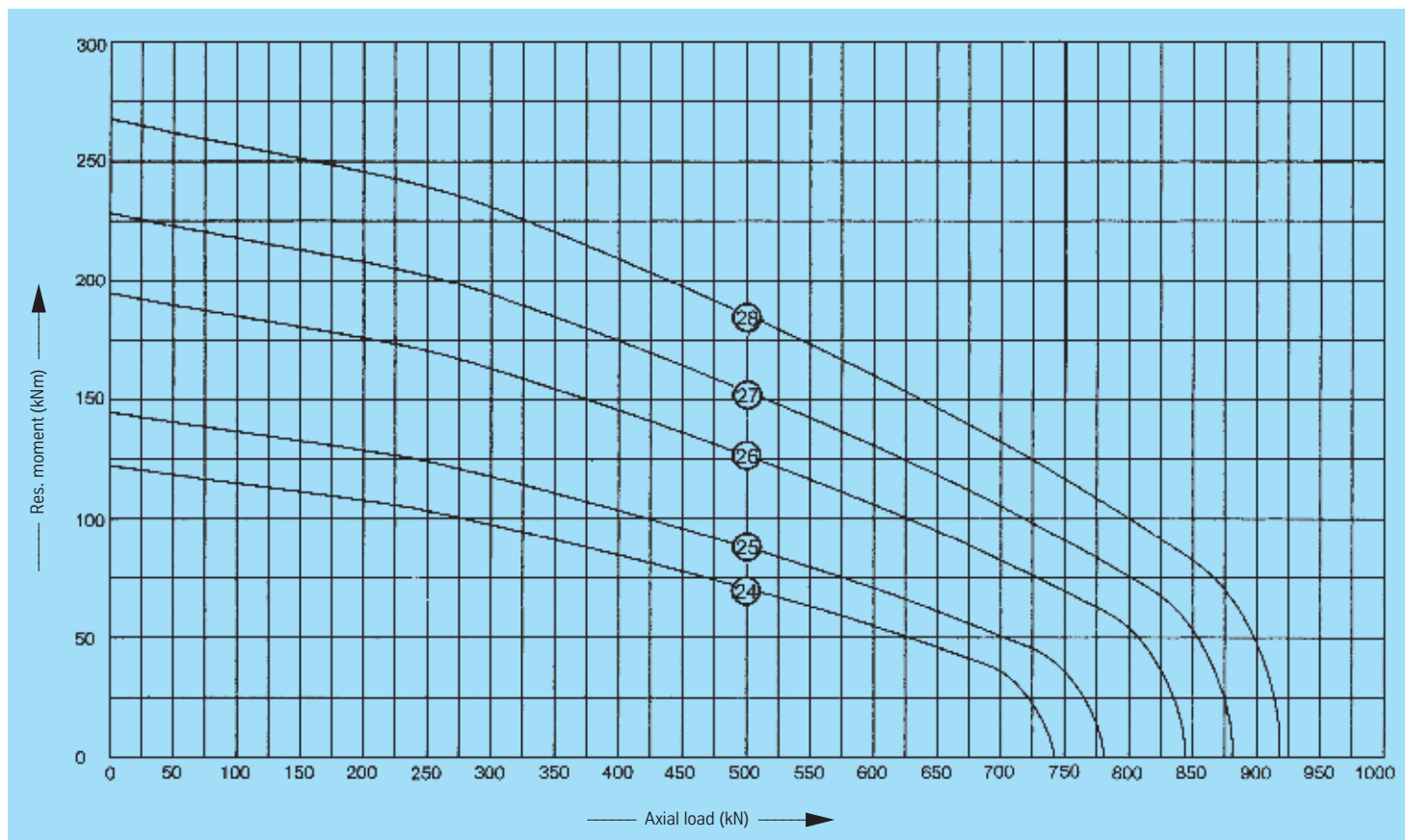

Standard series KD 600



Rothe Erde
Slewing Bearings

Bearings with internal gear

Drawing No. Ball track dia. D_L [mm]	Weight [kg]	Outer diameter (O.D.) D_o [mm]	Inner diameter (I.D.) D_i [mm]	Overall height H [mm]	External bolt circle dia. L_e [mm]	Internal bolt circle dia. L_i [mm]	Number of bolt holes per hole circle n	Bolt hole diameter B [mm]	Bolt size M [mm]	Number of grease nipples n_1	Diameter O [mm]	Diameter U [mm]	Ring height H_1 [mm]	Ring height H_2 [mm]	Distance at bottom Outer ring/inner ring H_b [mm]	Distance at top Outer ring/inner ring H_o [mm]	Gear P.C.D. d [mm]	Module m [mm]	Number of teeth z	Addendum modification sign per DIN 3960 October, 1976 $x \cdot m$ [mm]	Addendum reduction $k \cdot m$ [mm]	Tooth width b [mm]	Permissible tangential forces, normal [kN]	Permissible tangential forces, maximum [kN]	Curves
062.25.0886.800.11.1504 062.25.0886.801.21.1504	111	980	752	63	944	827	36	17,5	16	4	885	887	54	54	9	9	760	8	95	-4,0	-	54	27,13 41,74	54,26 83,48	29
062.25.1077.890.11.1503 062.25.1077.891.21.1503	140	1169	930	63	1134	1017	36	17,5	16	6	1076	1078	54	54	9	9	940	10	94	-5,0	-	54	33,91 52,17	67,82 104,34	30
062.25.1180.000.11.1504 062.25.1180.001.21.1504	185	1287	1020	69	1243	1117	36	22	20	6	1179	1181	60	54	15	9	1030	10	103	-5,0	-	60	37,65 57,97	75,30 115,94	31

Gear normalized

Gear quenched and tempered

Static limiting load curves

—— Raceway - - - Bolts

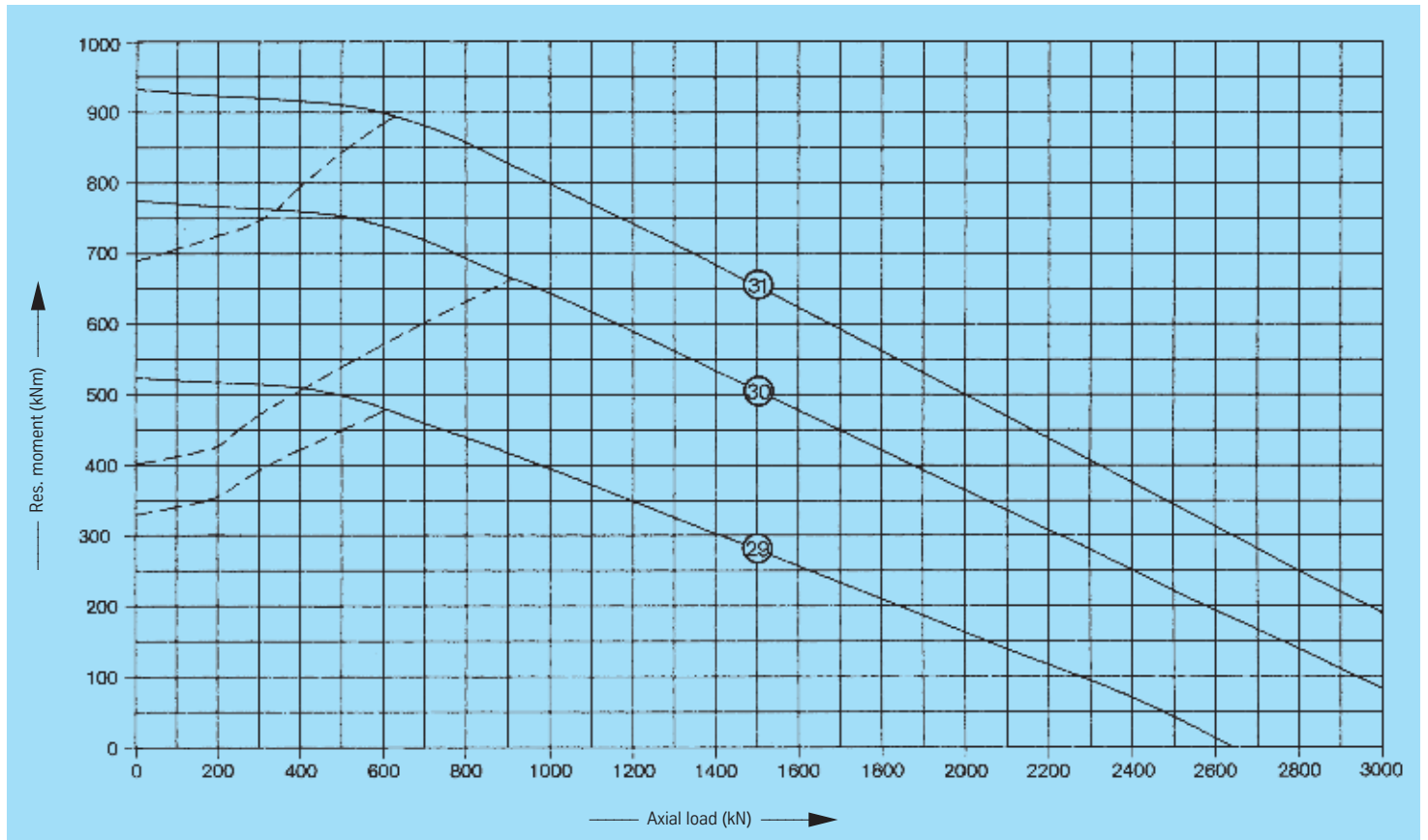

Standard series KD 600



Rothe Erde
Slewing Bearings

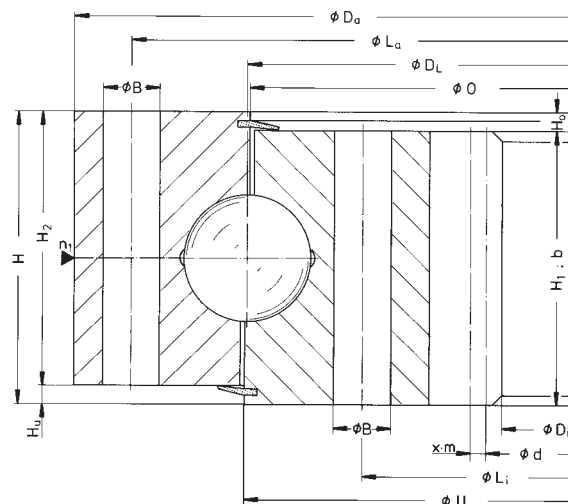

Service life curves · 30,000 revolutions

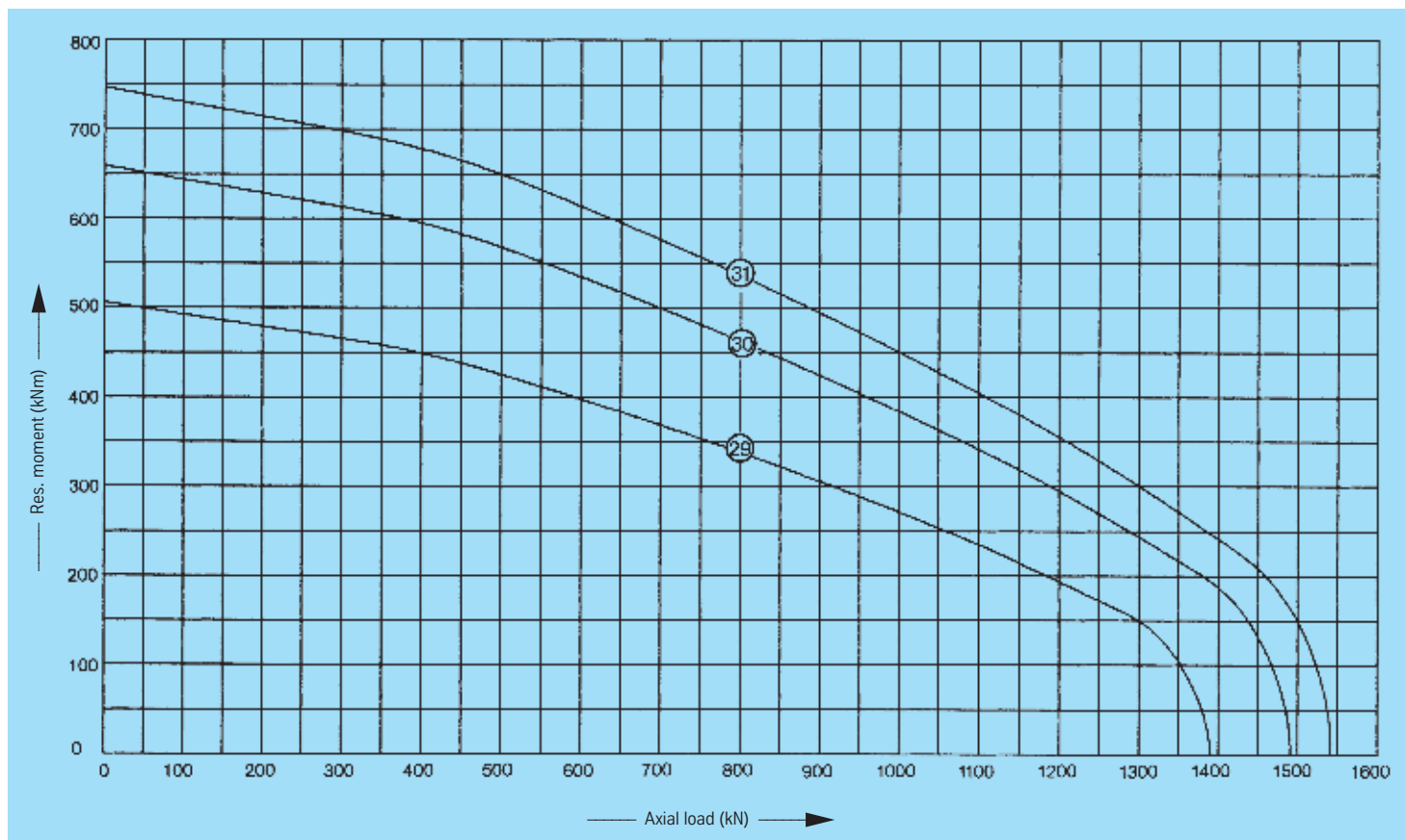

Standard series KD 600



Rothe Erde
Slewing Bearings

Bearings with internal gear

Drawing No. Ball track dia. D_L [mm]	Weight [kg]	Outer diameter (O.D.) D_o [mm]	Inner diameter (I.D.) D_i [mm]	Overall height H [mm]	External bolt circle dia. L_e [mm]	Internal bolt circle dia. L_i [mm]	Number of bolt holes per hole circle n	Bolt hole diameter B [mm]	Bolt size M [mm]	Number of grease nipples n_1	Diameter O [mm]	Diameter U [mm]	Ring height H_1 [mm]	Ring height H_2 [mm]	Distance at bottom Outer ring/inner ring H_b [mm]	Distance at top Outer ring/inner ring H_o [mm]	Gear P.C.D. d [mm]	Module m [mm]	Number of teeth z	Addendum modification sign per DIN 3960 October, 1976 $x \cdot m$ [mm]	Addendum reduction $k \cdot m$ [mm]	Tooth width b [mm]	Permissible tangential forces, normal [kN]	Permissible tangential forces, maximum [kN]	Curves
062.30.1120.000.11.1504 062.30.1120.001.21.1504	206	1232	960	79	1188	1052	36	22	20	6	1118	1121	70	63	16	9	970	10	97	-5,0	-	70	43,95 67,63	87,90 135,26	32
062.30.1250.000.11.1504 062.30.1250.001.21.1504	231	1362	1090	79	1318	1182	40	22	20	8	1248	1251	70	63	16	9	1100	10	110	-5,0	-	70	43,95 67,63	87,90 135,26	33
062.30.1400.000.11.1504 062.30.1400.001.21.1504	296	1512	1224	89	1468	1332	44	22	20	11	1398	1401	80	63	26	9	1236	12	103	-6,0	-	80	60,30 88,10	120,60 176,20	34
062.30.1600.000.11.1504 062.30.1600.001.21.1504	334	1712	1428	89	1668	1532	48	22	20	8	1598	1601	80	63	26	9	1440	12	120	-6,0	-	80	60,30 88,10	120,60 176,20	35

Gear normalized
Gear quenched and tempered

Static limiting load curves

—— Raceway - - - Bolts

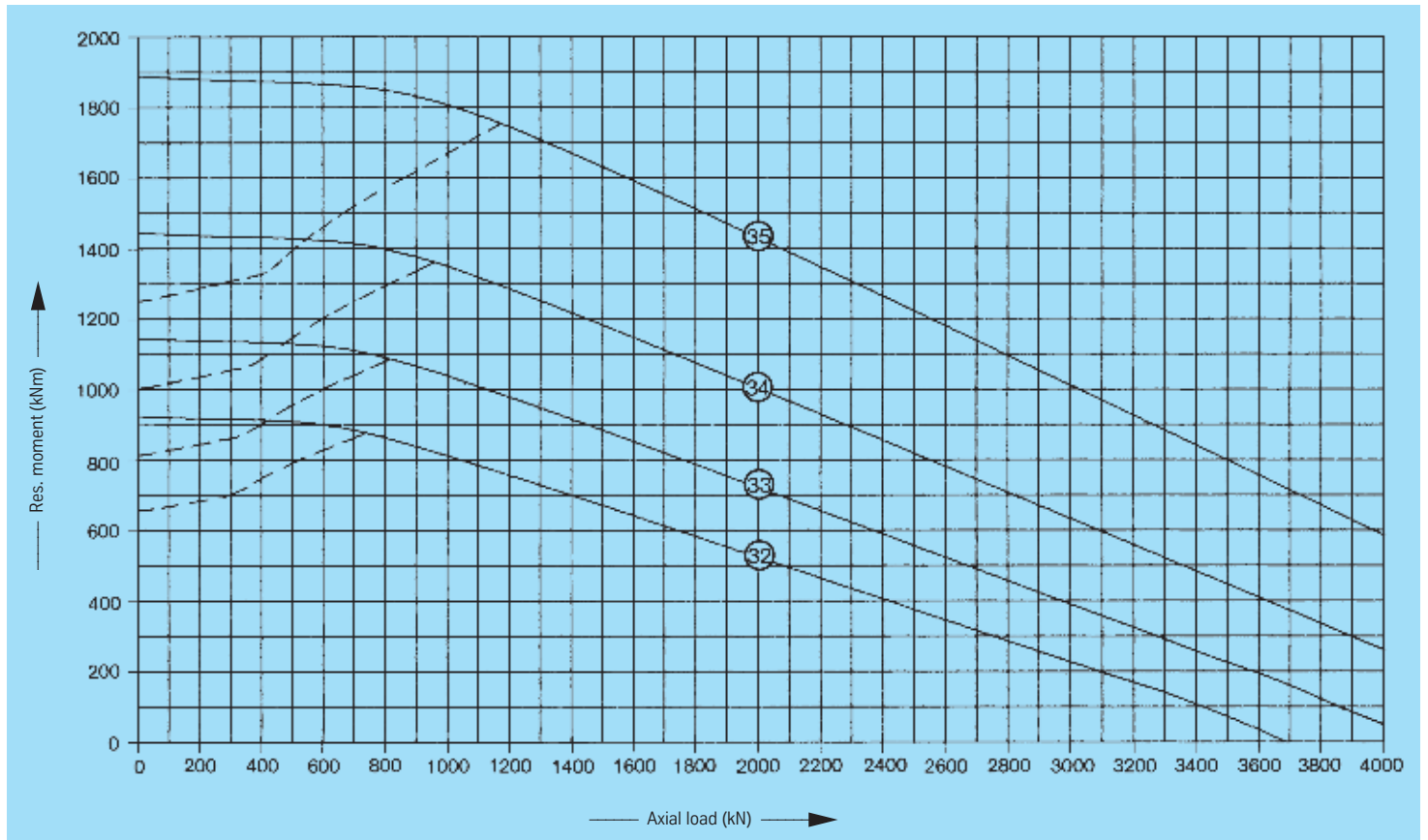

Standard series KD 600



Rothe Erde
Slewing Bearings

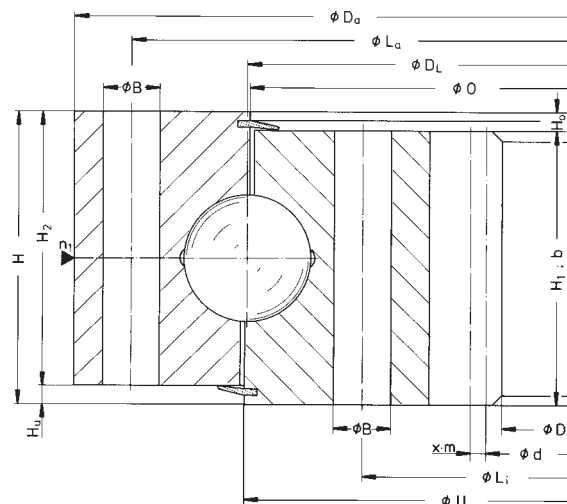

Service life curves · 30,000 revolutions

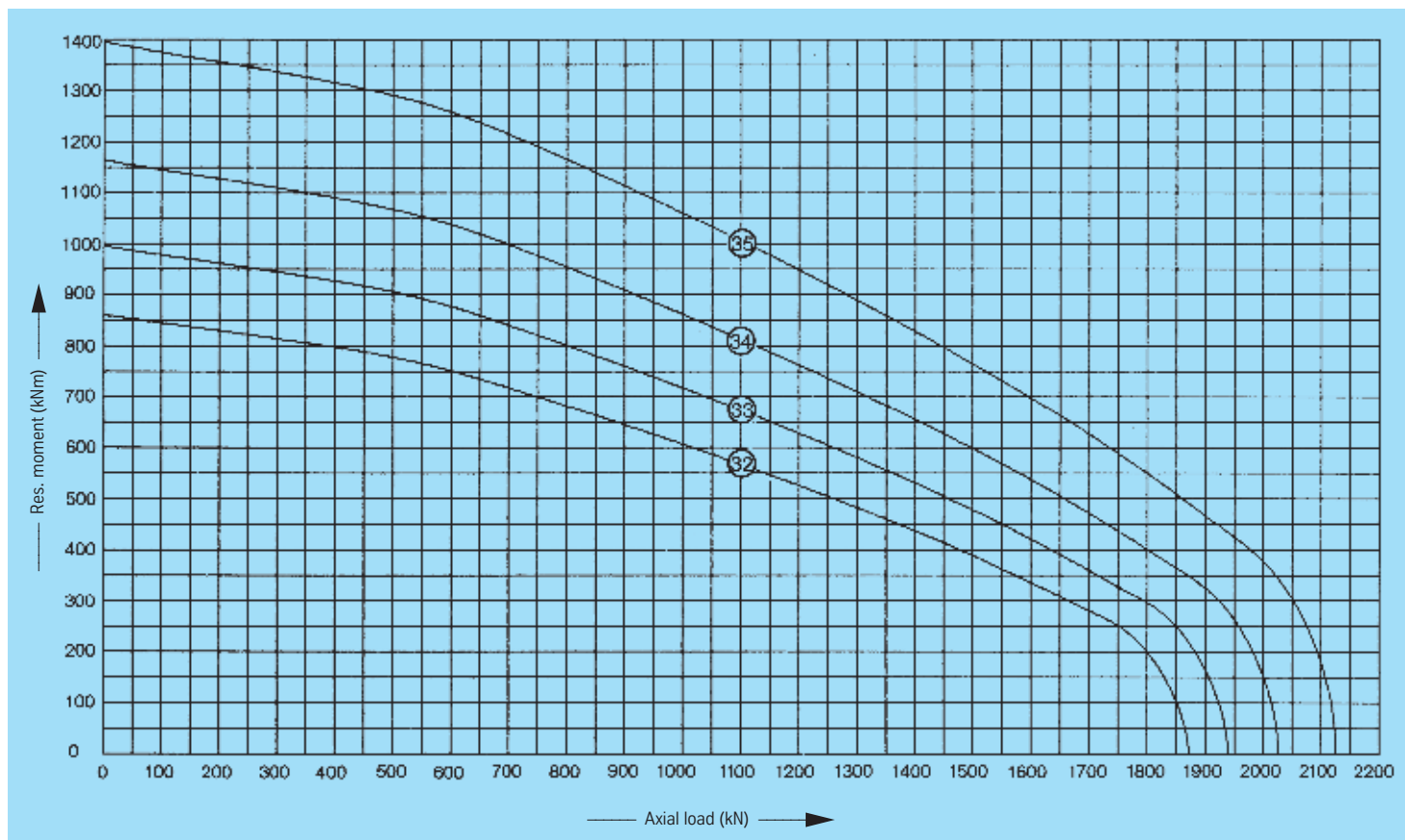

Standard series KD 600



Rothe Erde
Slew Bearings

Bearings with internal gear

Drawing No. Ball track dia. D_L [mm]	Weight [kg]	Outer diameter (O.D.) D_o [mm]	Inner diameter (I.D.) D_i [mm]	Overall height H [mm]	External bolt circle dia. L_e [mm]	Internal bolt circle dia. L_i [mm]	Number of bolt holes per hole circle n	Bolt hole diameter B [mm]	Bolt size M [mm]	Number of grease nipples n_1	Diameter O [mm]	Diameter U [mm]	Ring height H_1 [mm]	Ring height H_2 [mm]	Distance at bottom Outer ring/inner ring H_b [mm]	Distance at top Outer ring/inner ring H_o [mm]	Gear P.C.D. d [mm]	Module m [mm]	Number of teeth z	Addendum modification sign per DIN 3960 October, 1976 $x \cdot m$ [mm]	Addendum reduction $k \cdot m$ [mm]	Tooth width b [mm]	Permissible tangential forces, normal [kN]	Permissible tangential forces, maximum [kN]	Curves
062.40.1500.000.19.1504 062.40.1500.001.29.1504	410	1634	1308	94	1582	1418	40	26	24	8	1498	1501	85	81	13	9	1320	12	110	-6,0	-	85	64,0	128,1	36
062.40.1700.007.19.1503 062.40.1700.008.29.1503	475	1834	1498	94	1782	1618	44	26	24	11	1698	1701	85	81	13	9	1512	14	108	-7,0	-	85	74,7	149,4	37

Gear normalized

Gear quenched and tempered

Static limiting load curves

—— Raceway - - - Bolts

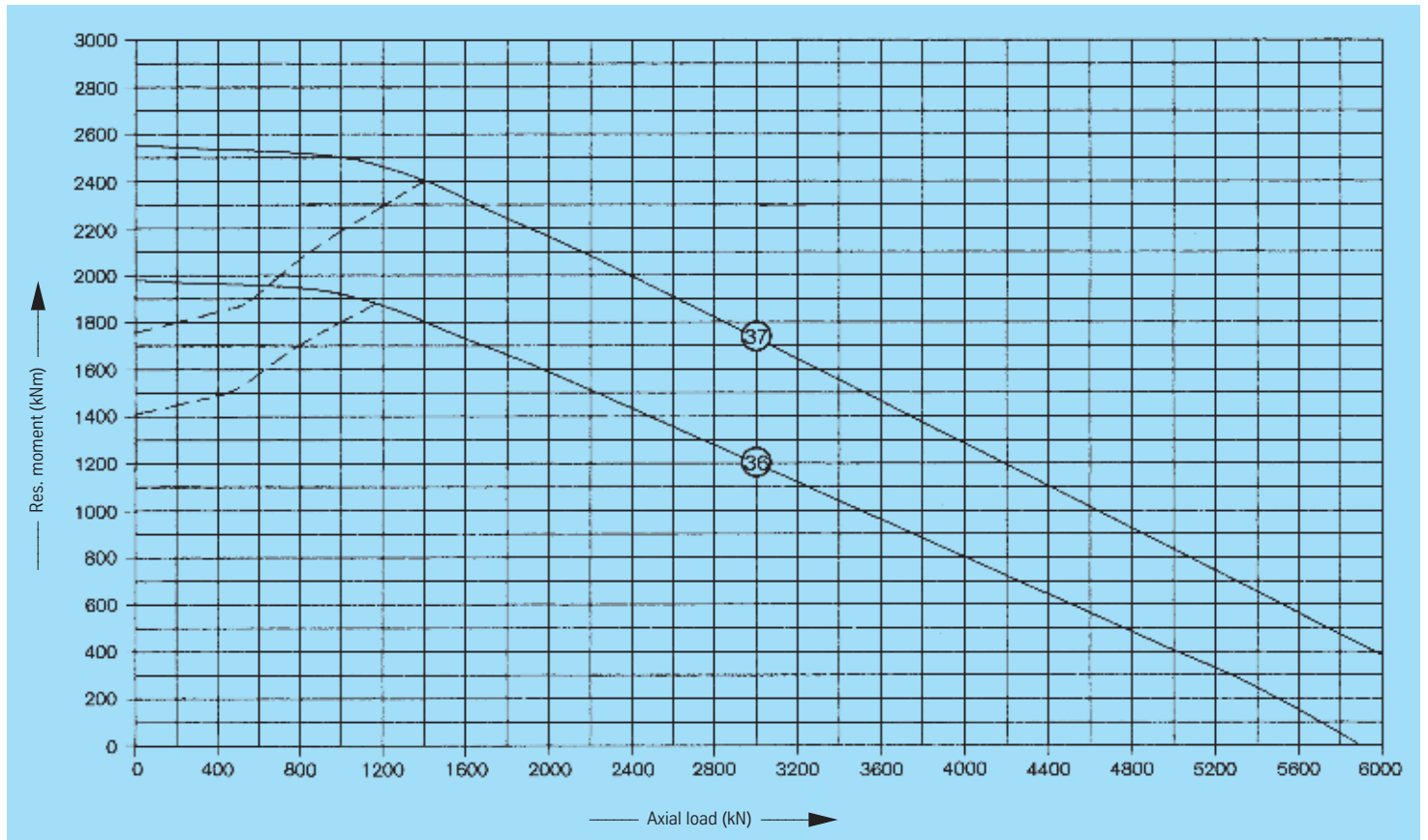

Standard series KD 600



Rothe Erde
Slewing Bearings

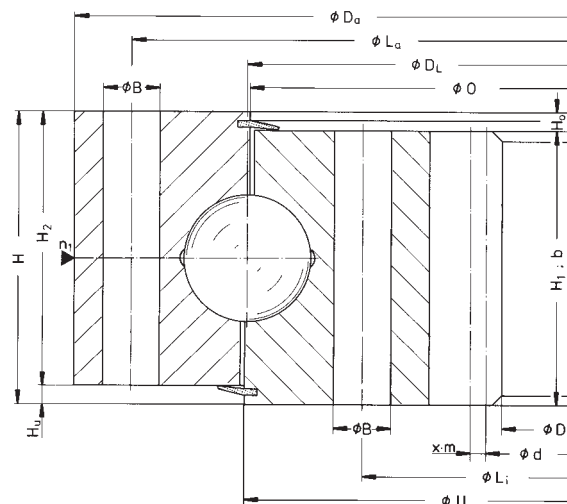

Service life curves · 30,000 revolutions

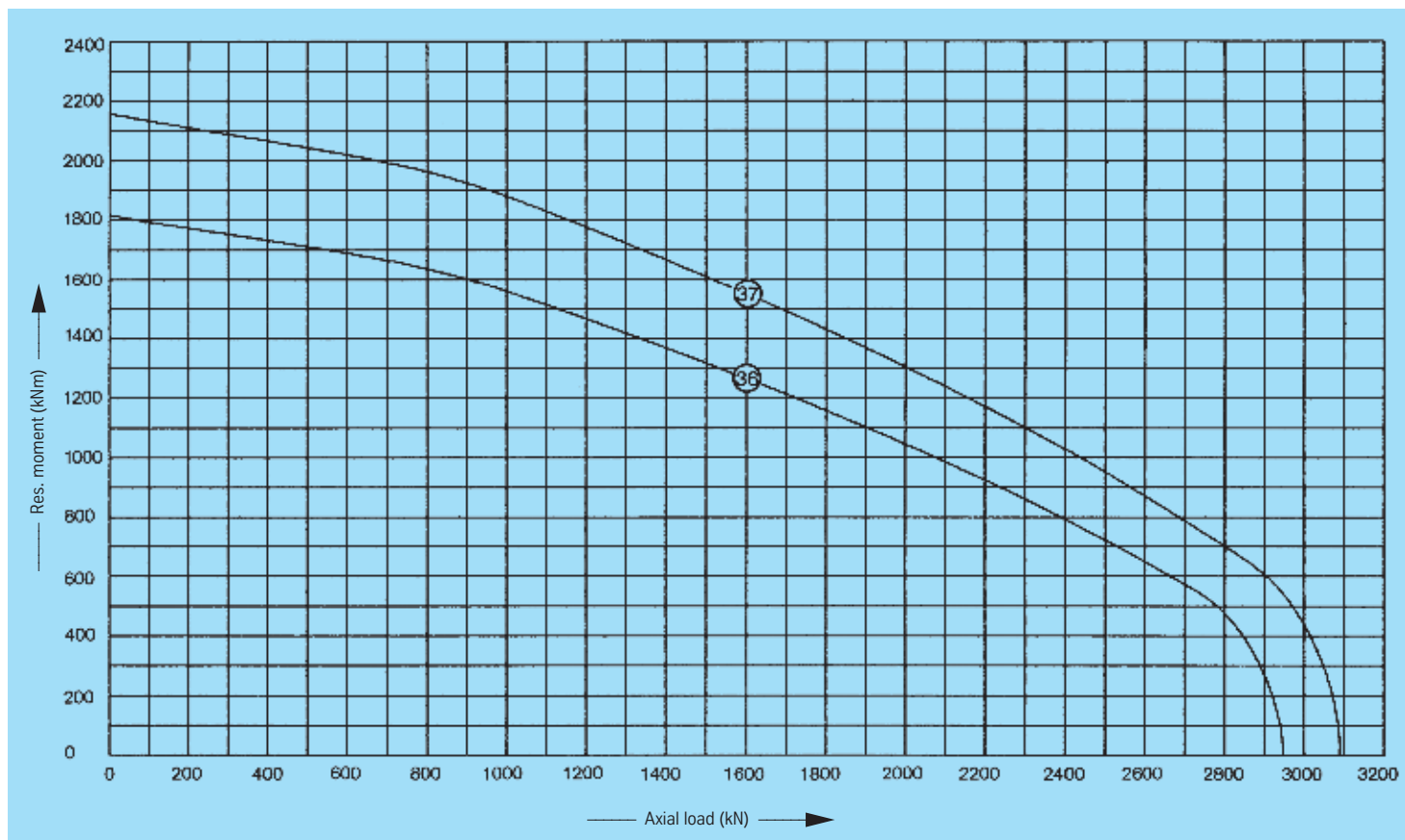

Standard series KD 600



Rothe Erde
Slew Bearings

Bearings with internal gear

Drawing No. Ball track dia. D_L [mm]	Weight [kg]	Outer diameter (O.D.) D_o [mm]	Inner diameter (I.D.) D_i [mm]	Overall height H [mm]	External bolt circle dia. L_e [mm]	Internal bolt circle dia. L_i [mm]	Number of bolt holes per hole circle n	Bolt hole diameter B [mm]	Bolt size M [mm]	Number of grease nipples n_1	Diameter O [mm]	Diameter U [mm]	Ring height H_1 [mm]	Ring height H_2 [mm]	Distance at bottom Outer ring/inner ring H_b [mm]	Distance at top Outer ring/inner ring H_o [mm]	Gear P.C.D. d [mm]	Module m [mm]	Number of teeth z	Addendum modification sign per DIN 3960 October, 1976 $x \cdot m$ [mm]	Addendum reduction $k \cdot m$ [mm]	Tooth width b [mm]	Permissible tangential forces, normal [kN]	Permissible tangential forces, maximum [kN]	Curves
062.50.1800.001.49.1504	762	1971	1554	109	1905	1695	36	33	30	9	1798	1802	100	99	10	9	1568	14	112	-7,0	-	100	128,5	257,0	38
062.50.2000.001.49.1504	843	2171	1764	109	2105	1895	40	33	30	8	1998	2002	100	99	10	9	1778	14	127	-7,0	-	100	128,5	257,0	39
062.50.2240.001.49.1504	961	2411	1984	109	2345	2135	48	33	30	8	2238	2242	100	99	10	9	2000	16	125	-8,0	-	100	146,8	293,6	40
062.50.2490.001.49.1504	1053	2661	2240	109	2595	2385	54	33	30	9	2488	2492	100	99	10	9	2256	16	141	-8,0	-	100	146,8	293,6	41
062.50.2800.001.49.1504	1205	2971	2544	109	2905	2695	60	33	30	12	2798	2802	100	99	10	9	2560	16	160	-8,0	-	100	146,8	293,6	42

Bearing rings quenched and tempered

Static limiting load curves

—— Raceway - - - Bolts

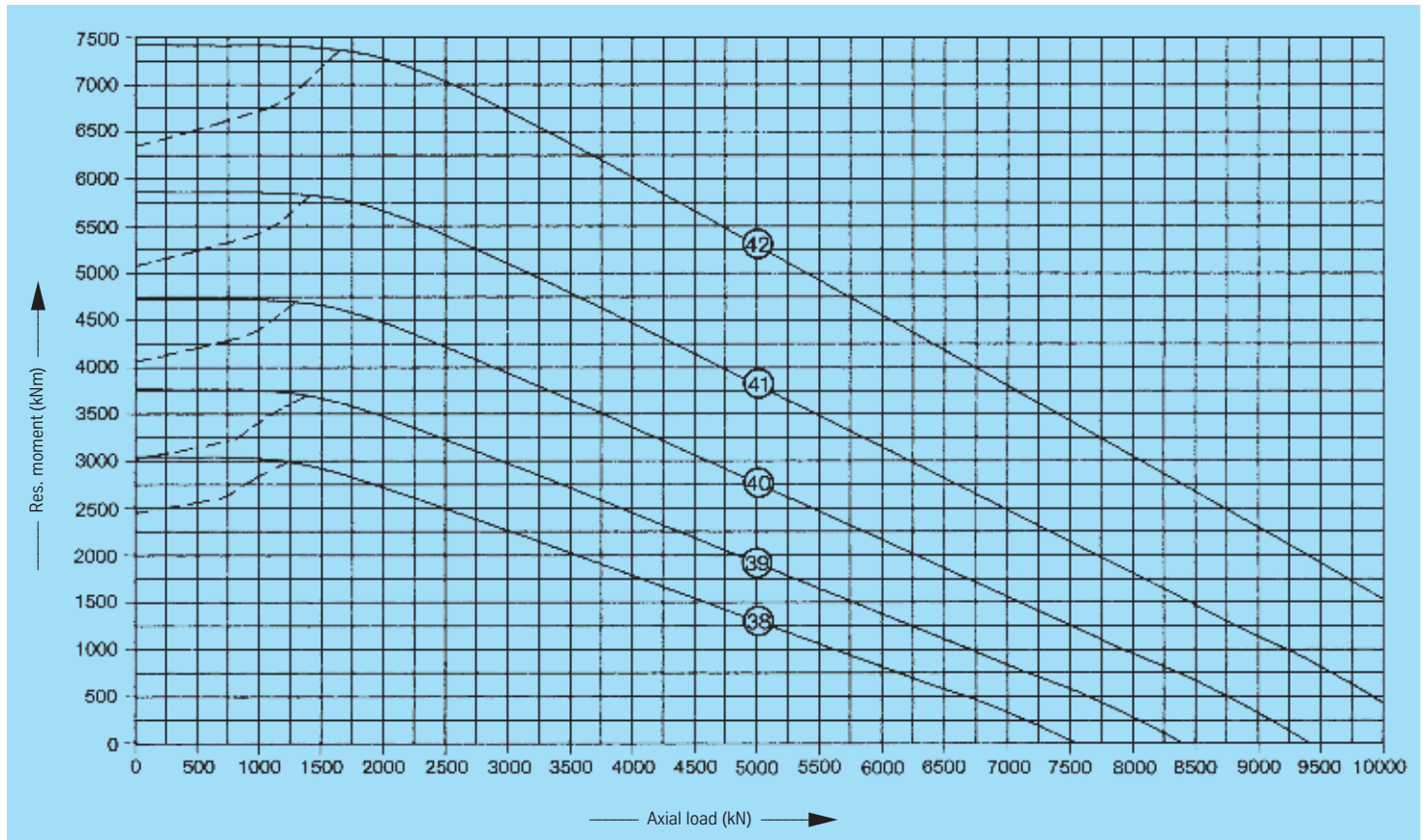

Standard series KD 600



Rothe Erde
Slewing Bearings

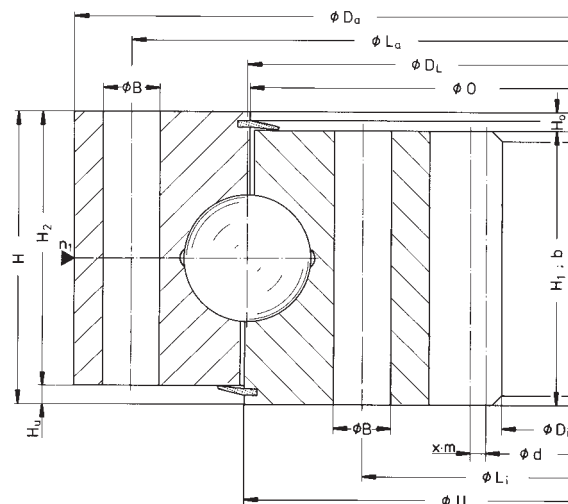

Service life curves · 30,000 revolutions

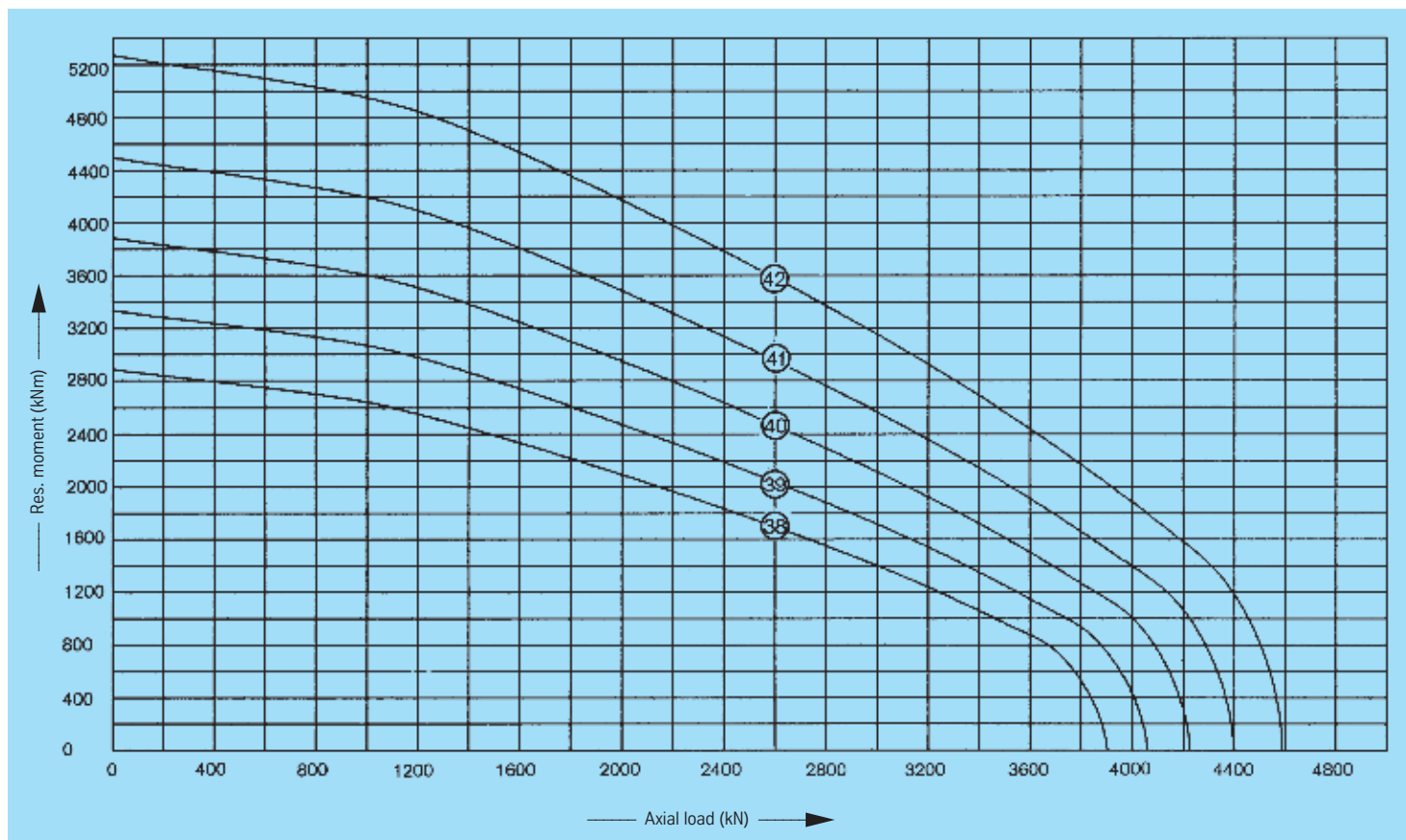



Standard series RD 700

Double-row slewing rings
Roller/ball combination bearings

Pages 123 – 133

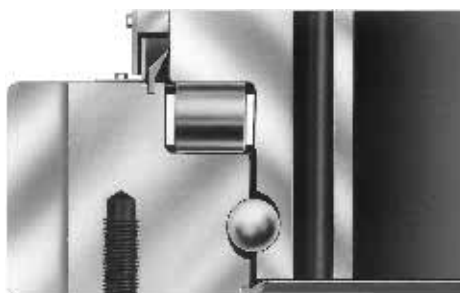

The bearing type shown on pages 124 – 133 is destined for applications with small eccentricities at relatively high axial loads, which call for a long service life even with continuous oscillating motions, and where the structural design requires a large bearing diameter. For this bearing type, the eccentricity

$$e = \frac{2 \cdot M_k \cdot 1000}{F_a \cdot D_L}$$

should not exceed 1.2 under operating loads. If in extreme static cases “e” is found to be higher than 2, verification by us will be necessary.

The entire load capacity ranges, which lie under the static load limiting curve and the operating load curve, are covered by the use of grade 10.9 bolts.

Standard series RD 700



Bearings with external gear

Drawing No. Roller track dia. D_L [mm]	Weight [kg]	Outer diameter (O.D.) D_o [mm]	Inner diameter (I.D.) D_i [mm]	Overall height H [mm]	External bolt circle dia. L_e [mm]	Internal bolt circle dia. L_i [mm]	Number of bolt holes per hole circle n	Bolt hole diameter B [mm]	Bolt size M [mm]	Number of grease nipples per level n_1	Diameter O [mm]	Diameter U [mm]	Ring height H_1 [mm]	Ring height H_2 [mm]	Distance at bottom Outer ring/inner ring H_u [mm]	Distance at top Outer ring/inner ring H_o [mm]	Gear P.C.D. d [mm]	Module m [mm]	Number of teeth z	Addendum modification sign per DIN 3960 October, 1976 $x \cdot m$ [mm]	Addendum reduction $k \cdot m$ [mm]	Tooth width b [mm]	Permissible tangential forces, normal [kN]	Permissible tangential forces, maximum [kN]	Curves
121.32.3550.990.41.1502	2028	3772,8	3358	159	3638	3418	76	30	27	10	3597	3509	109	143	16	50	3712	16	232	+16	-1,6	109	160	320	①
121.32.3750.990.41.1502	2186	3980,8	3558	159	3846	3618	80	30	27	10	3797	3709	109	143	16	50	3936	16	246	+ 8	-1,6	109	160	320	②
121.32.4000.990.41.1502	2278	4220,8	3808	159	4086	3868	84	30	27	12	4047	3959	109	143	16	50	4176	16	261	+ 8	-1,6	109	160	320	③
121.32.4250.990.41.1502	2455	4476,8	4058	159	4342	4118	90	30	27	12	4297	4209	109	143	16	50	4416	16	276	+16	-1,6	109	160	320	④

Bearing rings quenched and tempered

Static limiting load curves

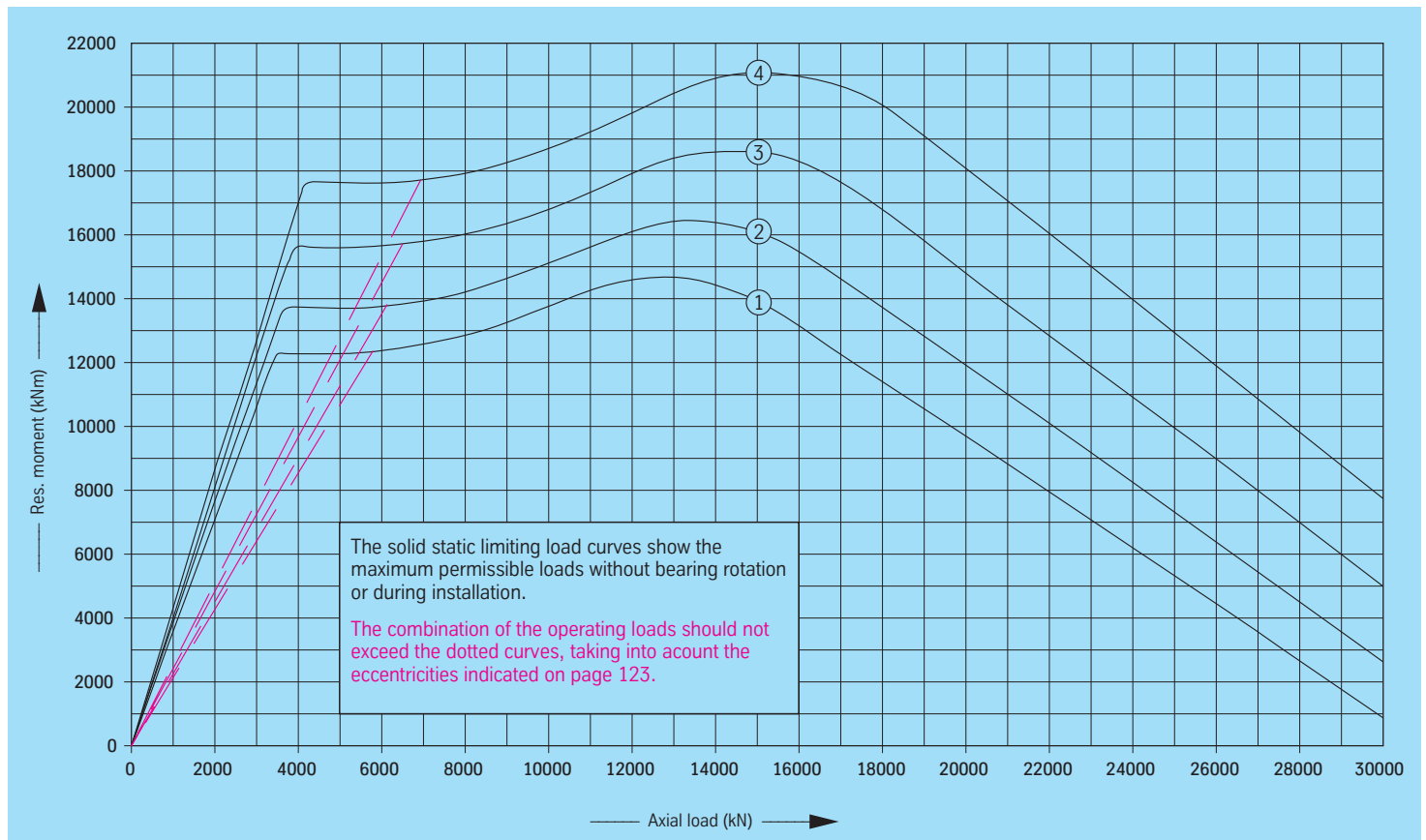

Standard series RD 700



Rothe Erde
Slewing Bearings

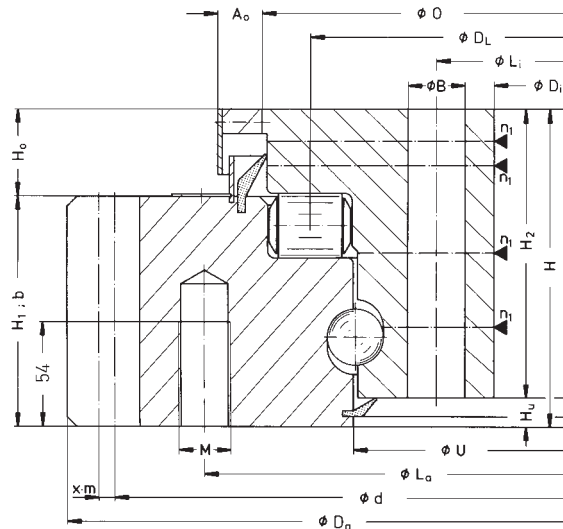

Service life curves · 30,000 revolutions

drawing position = mounting position

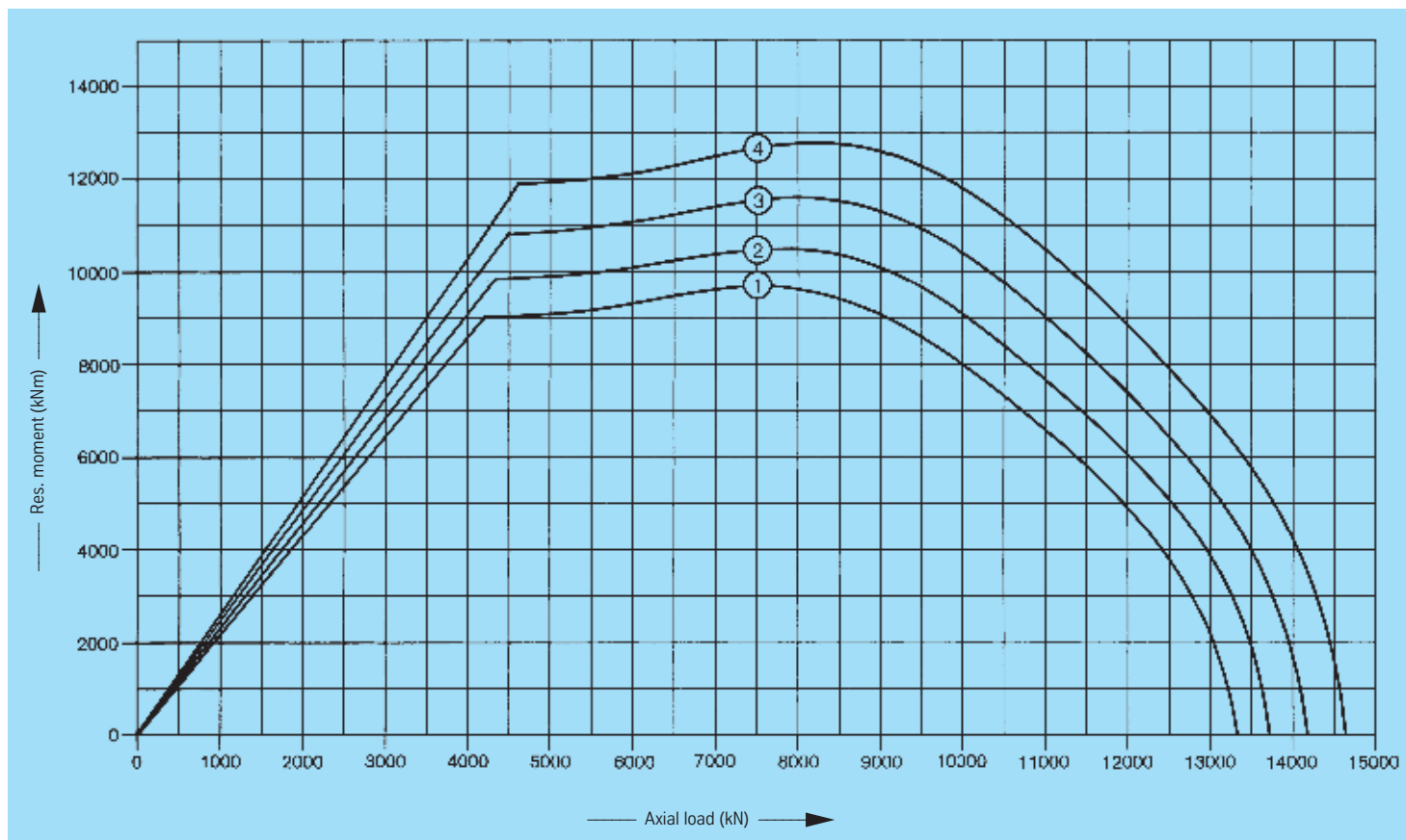

Standard series RD 700



Bearings with external gear

Drawing No. Roller track dia. D_L [mm]	Weight [kg]	Outer diameter (O.D.) D_o [mm]	Inner diameter (I.D.) D_i [mm]	Overall height H [mm]	External bolt circle dia. L_e [mm]	Internal bolt circle dia. L_i [mm]	Number of bolt holes per hole circle n	Bolt hole diameter B [mm]	Bolt size M [mm]	Number of grease nipples per level n_1	Diameter O [mm]	Diameter U [mm]	Ring height H_1 [mm]	Ring height H_2 [mm]	Distance at bottom Outer ring/inner ring H_u [mm]	Distance at top Outer ring/inner ring H_o [mm]	Gear P.C.D. d [mm]	Module m [mm]	Number of teeth z	Addendum modification sign per DIN 3960 October, 1976 $x \cdot m$ [mm]	Addendum reduction $k \cdot m$ [mm]	Tooth width b [mm]	Permissible tangential forces, normal [kN]	Permissible tangential forces, maximum [kN]	Curves
121.36.4000.990.41.1502	2792	4244,4	3792	175	4095	3858	76	33	30	12	4051	3955	125	159	16	50	4176	18	232	+18	-1,8	125	195,6	391,2	5
121.36.4250.990.41.1502	2981	4496,4	4042	175	4347	4108	80	33	30	12	4301	4205	125	159	16	50	4446	18	247	+9	-1,8	125	195,6	391,2	6
121.36.4500.990.41.1502	3173	4748,4	4292	175	4599	4358	84	33	30	14	4551	4455	125	159	16	50	4698	18	261	+9	-1,8	125	195,6	391,2	7
121.36.4750.990.41.1502	3363	5000,4	4542	175	4851	4608	90	33	30	14	4801	4705	125	159	16	50	4950	18	275	+9	-1,8	125	195,6	391,2	8

Bearing rings quenched and tempered

Static limiting load curves

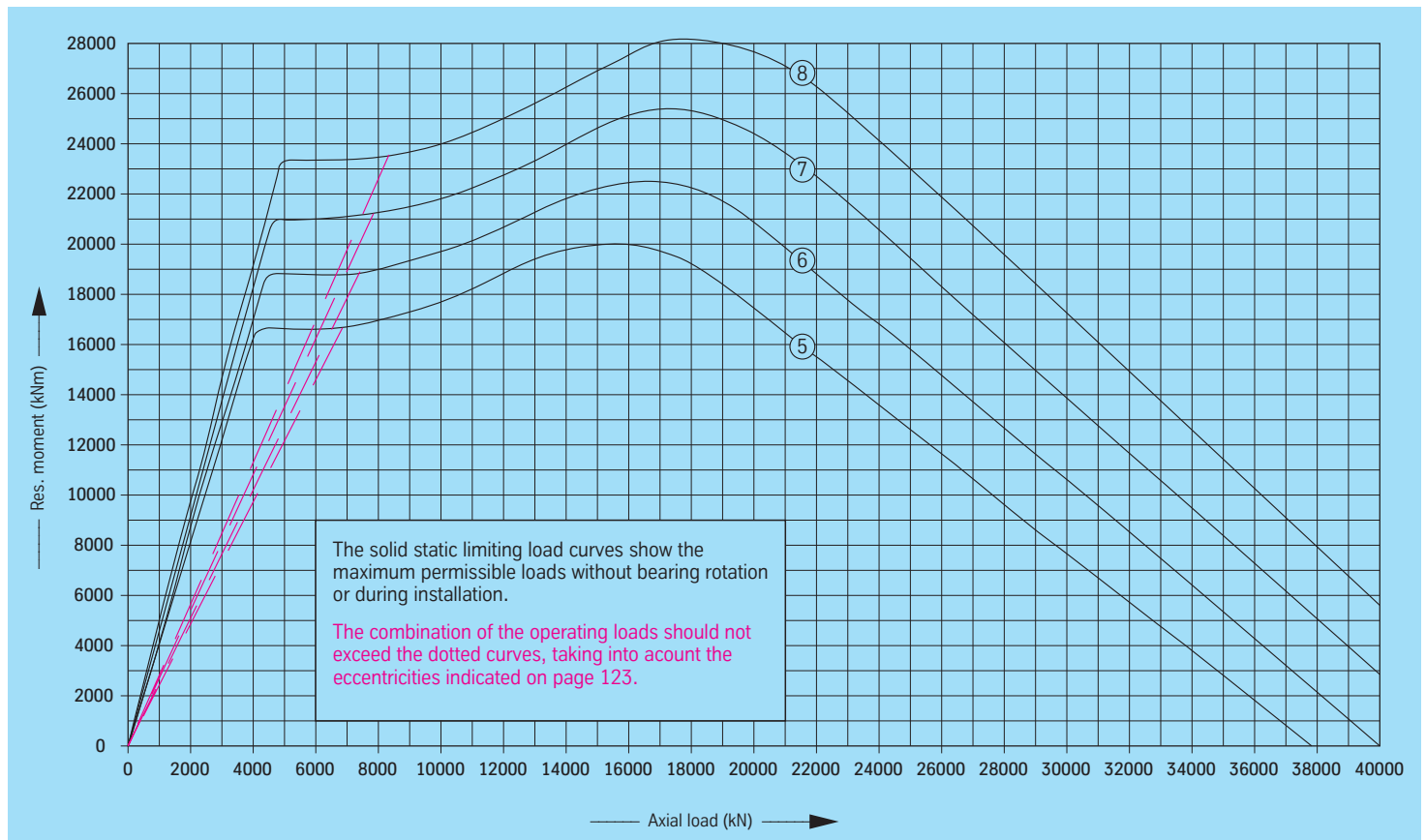

Standard series RD 700



Rothe Erde
Slewing Bearings

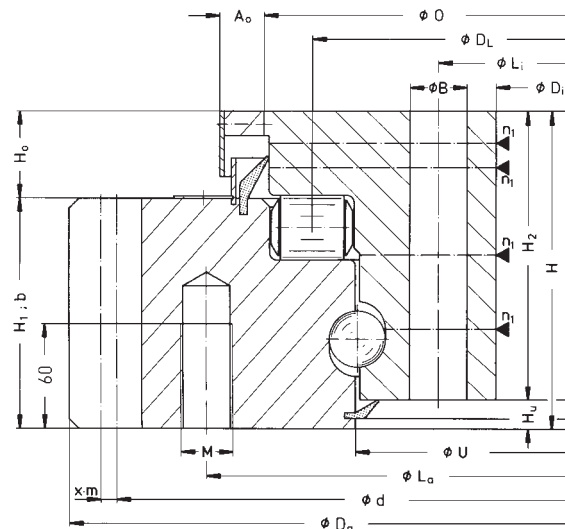

Service life curves · 30,000 revolutions

drawing position = mounting position

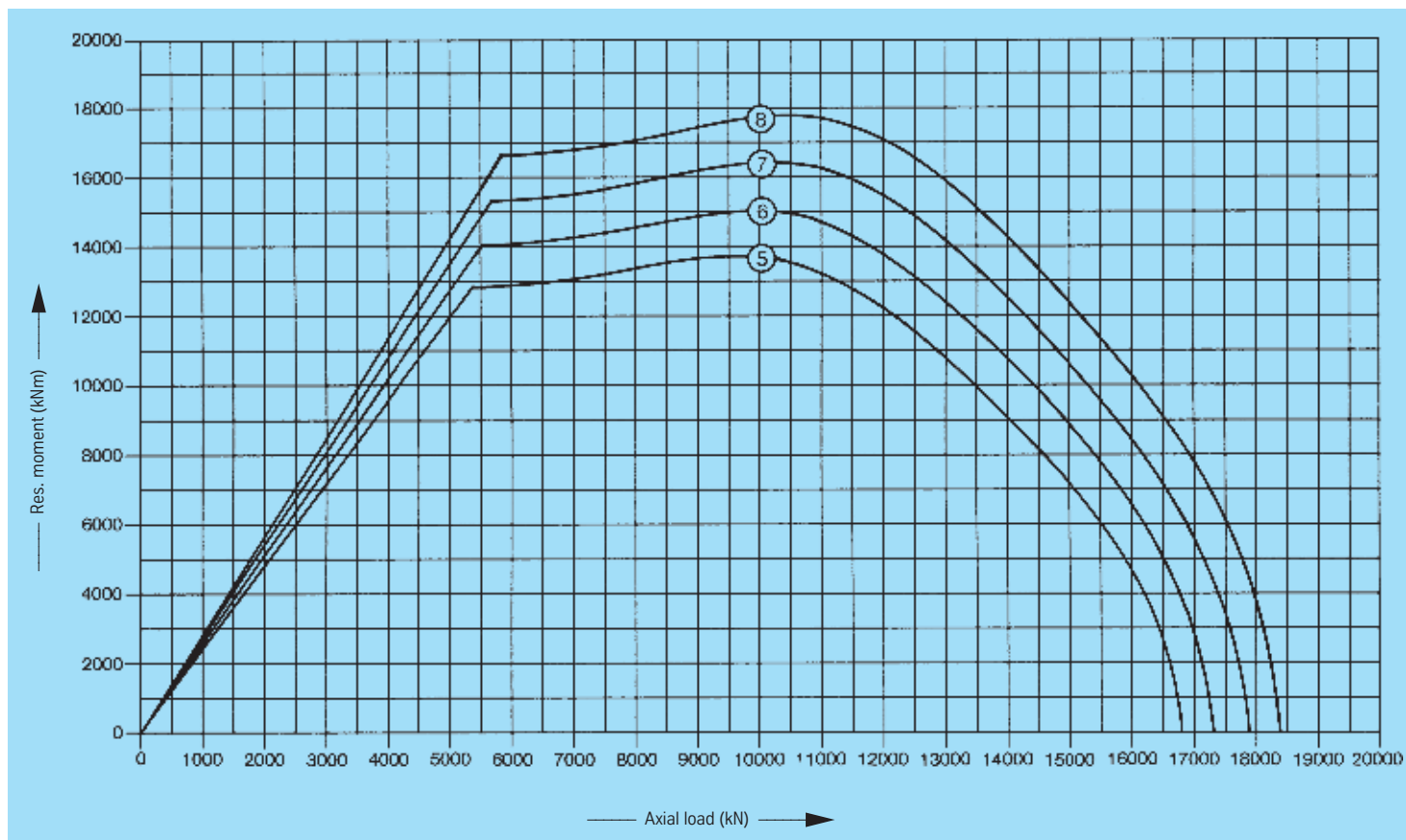

Standard series RD 700



Rothe Erde
Slewing Bearings

Bearings with external gear

Drawing No. Roller track dia. D_L [mm]	Weight [kg]	Outer diameter (O.D.) D_o [mm]	Inner diameter (I.D.) D_i [mm]	Overall height H [mm]	External bolt circle dia. L_e [mm]	Internal bolt circle dia. L_i [mm]	Number of bolt holes per hole circle n	Bolt hole diameter B [mm]	Bolt size M [mm]	Number of grease nipples per level n_1	Diameter O [mm]	Diameter U [mm]	Ring height H_1 [mm]	Ring height H_2 [mm]	Distance at bottom Outer ring/inner ring H_u [mm]	Distance at top Outer ring/inner ring H_o [mm]	Gear P.C.D. d [mm]	Module m [mm]	Number of teeth z	Addendum modification sign per DIN 3960 October, 1976 $x \cdot m$ [mm]	Addendum reduction $k \cdot m$ [mm]	Tooth width b [mm]	Permissible tangential forces, normal [kN]	Permissible tangential forces, maximum [kN]	Curves
121.40.4500.990.41.1502	3673	4776	4276	183	4612	4348	72	36	33	14	4556	4450	133	167	16	50	4720	20	236	+10	-2,0	133	231,3	462,6	9
121.40.4750.990.41.1502	3796	5016	4526	183	4852	4598	76	36	33	14	4806	4700	133	167	16	50	4960	20	248	+10	-2,0	133	231,3	462,6	10
121.40.5000.990.41.1502	4082	5276	4776	183	5112	4848	80	36	33	16	5056	4950	133	167	16	50	5220	20	261	+10	-2,0	133	231,3	462,6	11
121.40.5300.990.41.1502	4329	5576	5076	183	5412	5148	84	36	33	16	5356	5250	133	167	16	50	5520	20	276	+10	-2,0	133	231,3	462,6	12

Bearing rings quenched and tempered

Static limiting load curves

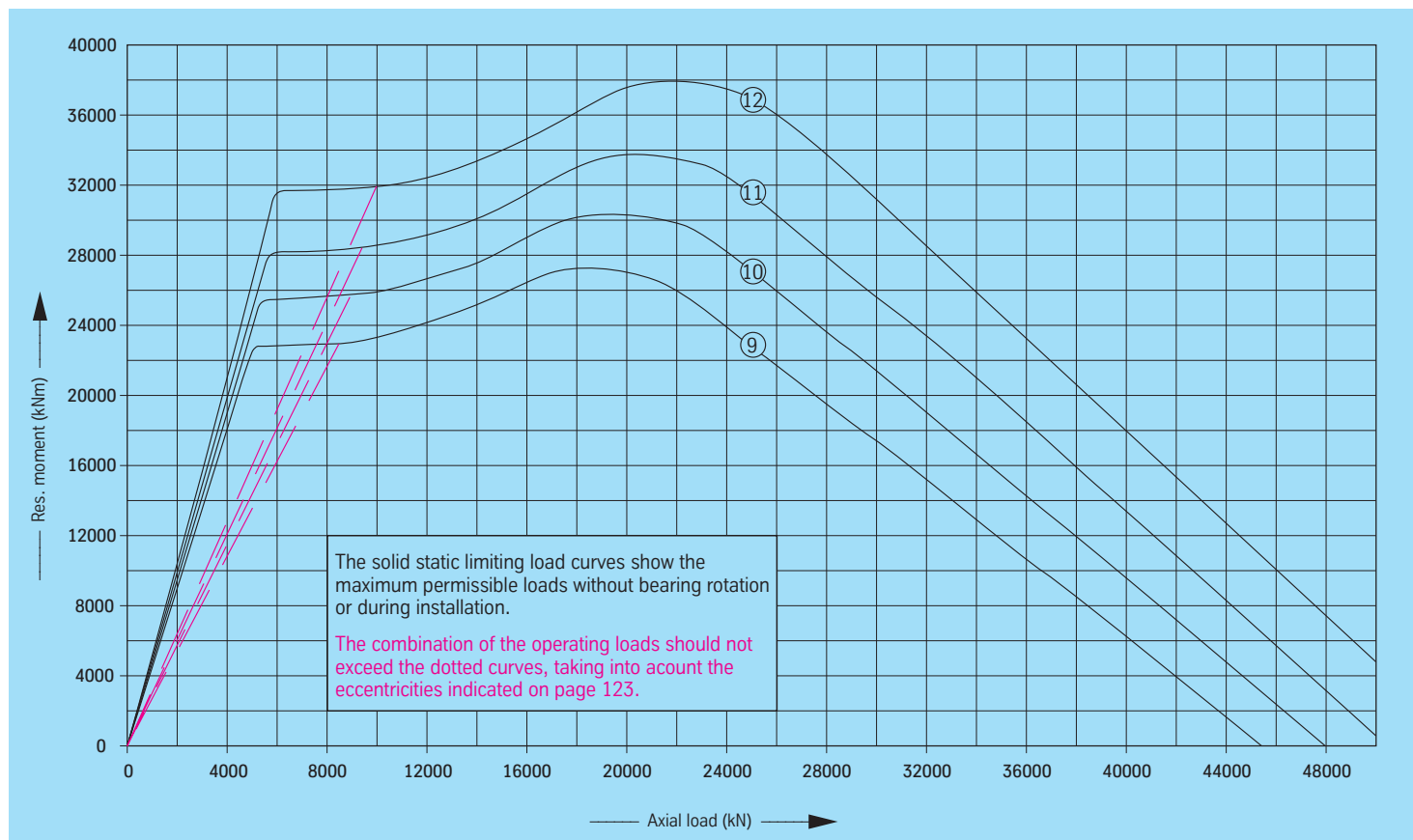

Standard series RD 700



Rothe Erde
Slewing Bearings

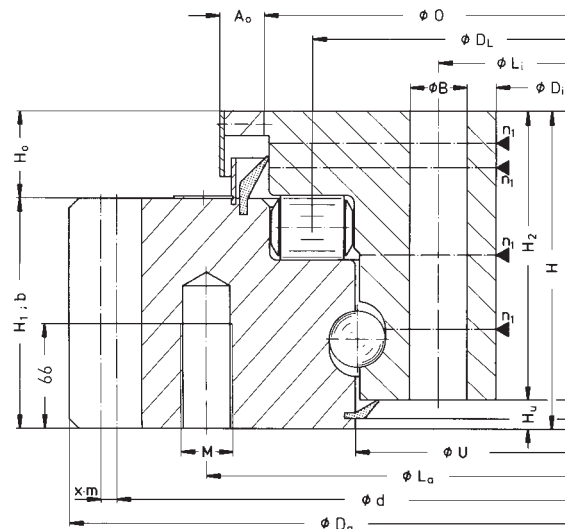

Service life curves · 30,000 revolutions

drawing position = mounting position

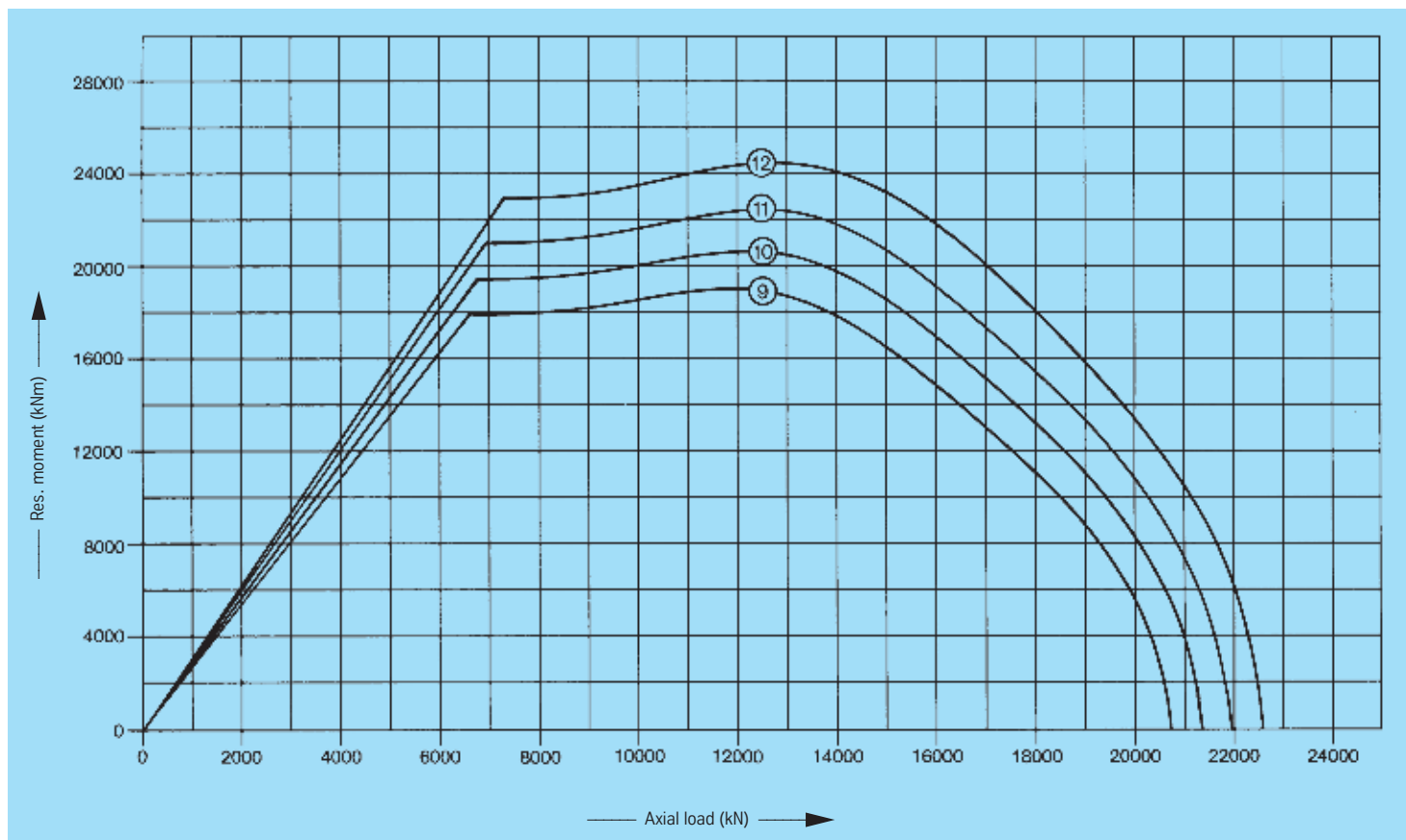

Standard series RD 700



Bearings with external gear

Drawing No. Roller track dia. D_L [mm]	Weight [kg]	Outer diameter (O.D.) D_o [mm]	Inner diameter (I.D.) D_i [mm]	Overall height H [mm]	External bolt circle dia. L_e [mm]	Internal bolt circle dia. L_i [mm]	Number of bolt holes per hole circle n	Bolt hole diameter B [mm]	Bolt size M [mm]	Number of grease nipples per level n_1	Diameter O [mm]	Diameter U [mm]	Ring height H_1 [mm]	Ring height H_2 [mm]	Distance at bottom Outer ring/inner ring H_u [mm]	Distance at top Outer ring/inner ring H_o [mm]	Gear P.C.D. d [mm]	Module m [mm]	Number of teeth z	Addendum modification sign per DIN 3960 October, 1976 $x \cdot m$ [mm]	Addendum reduction $k \cdot m$ [mm]	Tooth width b [mm]	Permissible tangential forces, normal [kN]	Permissible tangential forces, maximum [kN]	Curves
121.45.5000.990.41.1502	5201	5297,6	4747	203	5117	4825	76	39	36	16	5063	4945	153	187	16	50	5236	22	238	+11	-2,2	153	292,6	585,2	13
121.45.5300.990.41.1502	5602	5605,6	5047	203	5425	5125	80	39	36	16	5363	5245	153	187	16	50	5544	22	252	+11	-2,2	153	292,6	585,2	14
121.45.5600.990.41.1502	5764	5891,6	5347	203	5711	5425	84	39	36	18	5663	5545	153	187	16	50	5830	22	265	+11	-2,2	153	292,6	585,2	15
121.45.6000.990.41.1502	6129	6287,6	5747	203	6107	5825	90	39	36	18	6063	5945	153	187	16	50	6204	22	282	+22	-2,2	153	292,6	585,2	16

Bearing rings quenched and tempered

Static limiting load curves

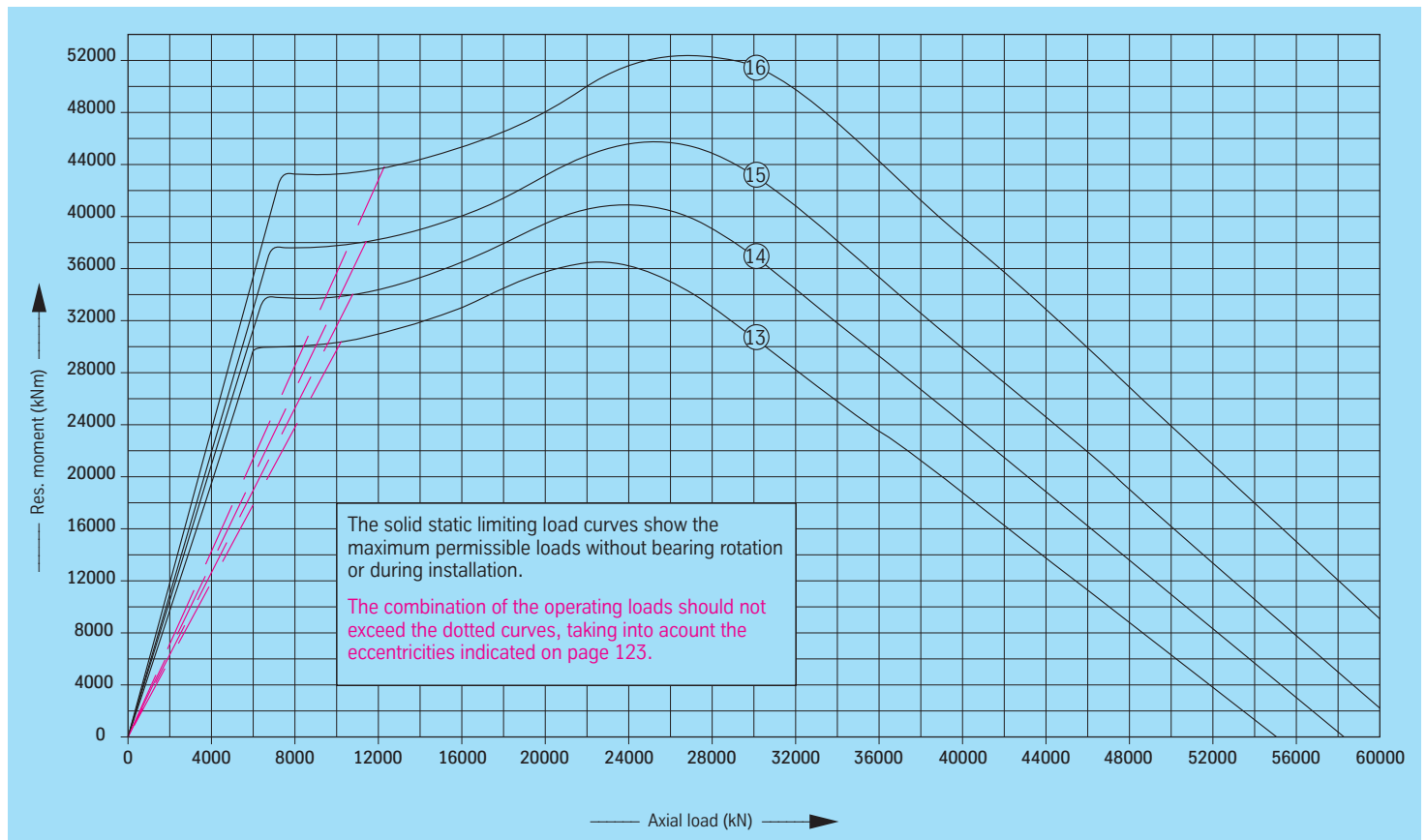

Standard series RD 700



Rothe Erde
Slewing Bearings

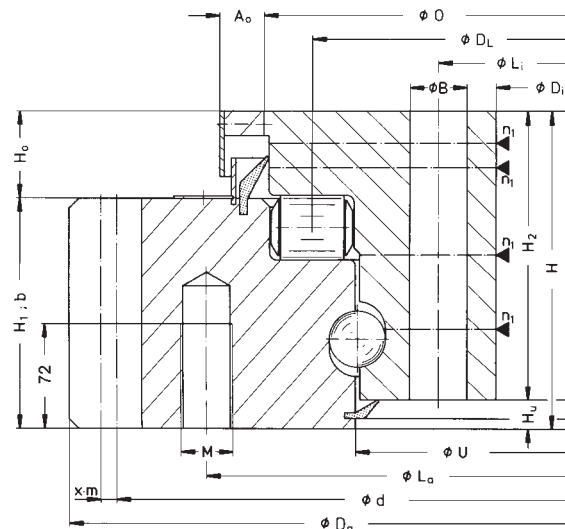

Service life curves · 30,000 revolutions

drawing position = mounting position

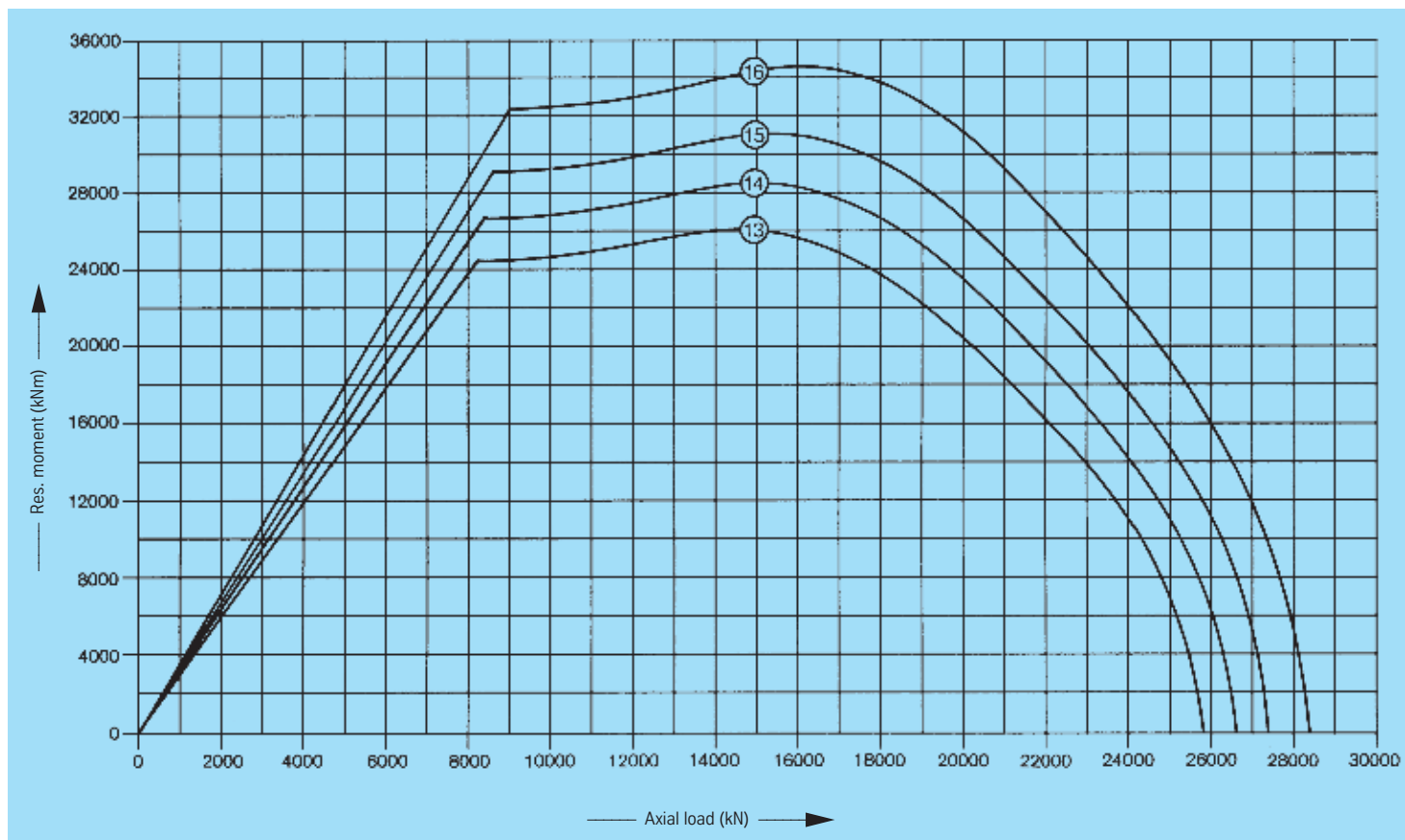

Standard series RD 700



Bearings with external gear

Drawing No. Roller track dia. D_L [mm]	Weight [kg]	Outer diameter (O.D.) D_a [mm]	Inner diameter (I.D.) D_i [mm]	Overall height H [mm]	External bolt circle dia. L_e [mm]	Internal bolt circle dia. L_i [mm]	Number of bolt holes per hole circle n	Bolt hole diameter B [mm]	Bolt size M [mm]	Number of grease nipples per level n_1	Diameter O [mm]	Diameter U [mm]	Ring height H_1 [mm]	Ring height H_2 [mm]	Distance at bottom Outer ring/inner ring H_u [mm]	Distance at top Outer ring/inner ring H_o [mm]	Gear P.C.D. d [mm]	Module m [mm]	Number of teeth z	Addendum modification sign per DIN 3960 October, 1976 $x \cdot m$ [mm]	Addendum reduction $k \cdot m$ [mm]	Tooth width b [mm]	Permissible tangential forces, normal [kN]	Permissible tangential forces, maximum [kN]	Curves
121.50.5600.990.41.1502	6397	5923,2	5342	221	5730	5420	90	39	36	18	5668	5540	156	205	16	65	5856	24	244	+12	-2,4	156	325,5	651,0	17
121.50.6000.990.41.1502	6663	6307,2	5742	221	6114	5820	96	39	36	18	6068	5940	156	205	16	65	6240	24	260	+12	-2,4	156	325,5	651,0	18
121.50.6700.990.41.1502	7708	7027,2	6442	221	6834	6520	108	39	36	20	6768	6640	156	205	16	65	6960	24	290	+12	-2,4	156	325,5	651,0	19

Bearing rings quenched and tempered

Static limiting load curves

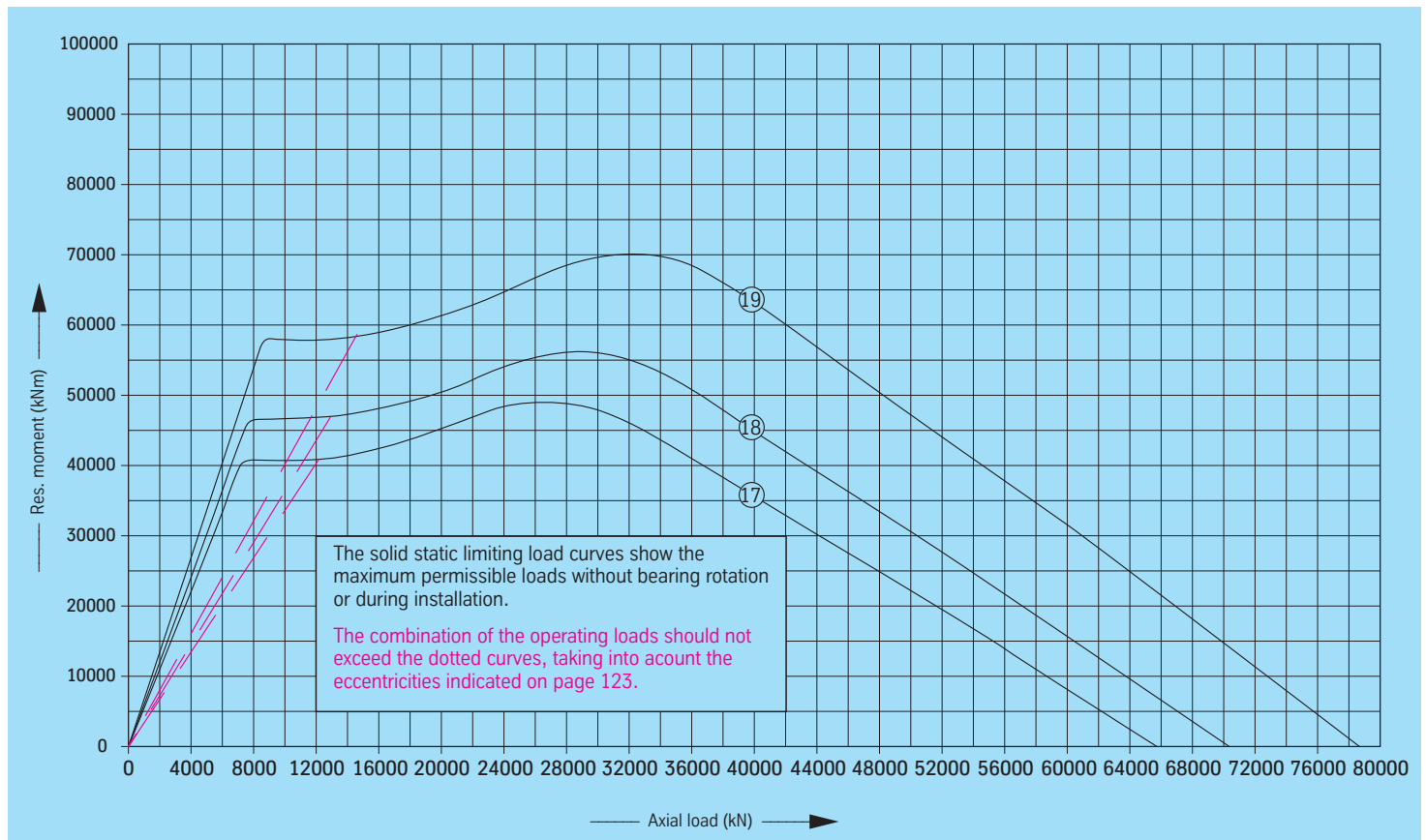

Standard series RD 700



Rothe Erde
Slewing Bearings

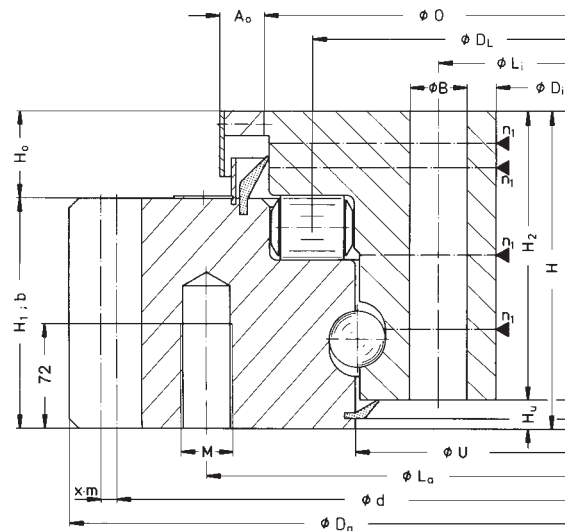

Service life curves · 30,000 revolutions

drawing position = mounting position

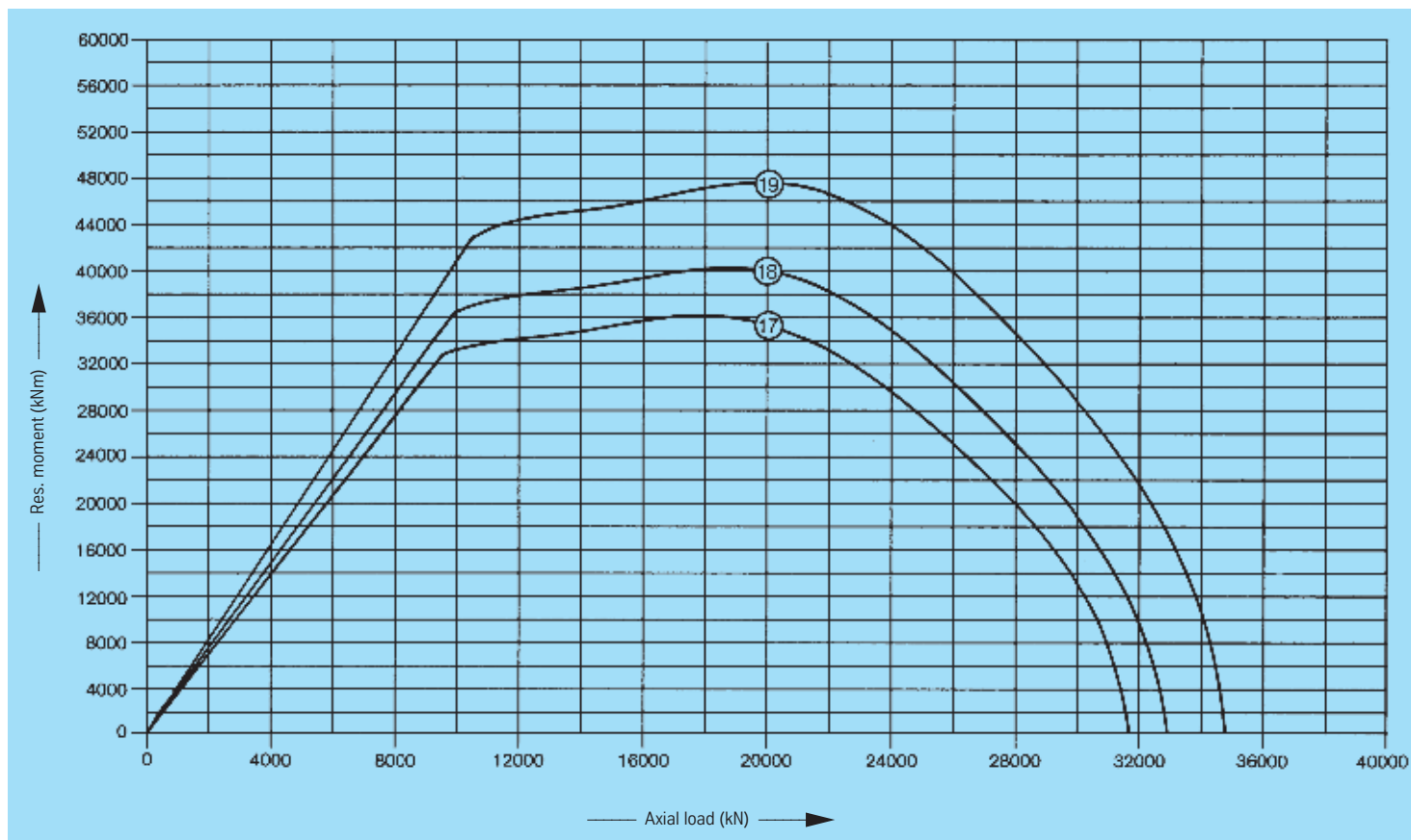



Rothe Erde
Slewing Bearings

Standard series RD 800

Single-row roller bearing slewing rings

Cross-roller bearings

Pages 135 – 153



Standard series RD 800



Rothe Erde
Slewing Bearings

Bearings with external gear

Drawing No. Roller track dia. D_k [mm]	Weight [kg]	Outer diameter (O.D.) D_o [mm]	Inner diameter (I.D.) D_i [mm]	Overall height H [mm]	External bolt circle dia. L_e [mm]	Internal bolt circle dia. L_i [mm]	Number of bolt holes per hole circle n	Bolt hole diameter B [mm]	Bolt size M [mm]	Number of grease nipples n_1	Diameter O [mm]	Diameter U [mm]	Ring height H_1 [mm]	Ring height H_2 [mm]	Distance at bottom Outer ring/inner ring H_b [mm]	Distance at top Outer ring/inner ring H_o [mm]	Gear P.C.D. d [mm]	Module m [mm]	Number of teeth z	Addendum modification sign per DIN 3960 October, 1976 $x \cdot m$ [mm]	Addendum reduction $k \cdot m$ [mm]	Tooth width b [mm]	Permissible tangential forces, normal [kN]	Permissible tangential forces, maximum [kN]	Curves
161.16.0400.890.11.1503 161.16.0400.891.21.1503	33	495,2	325	55	448	352	16	13,5	12	2	398	402	46	46	9	9	484	4	121	+2,0	-0,4	46	11,5 17,7	23,0 35,5	①
161.16.0450.890.11.1503 161.16.0450.891.21.1503	41	554	369	55	500	400	16	15,5	14	2	448	452	46	46	9	9	540	5	108	+2,5	-0,5	46	14,4 22,2	28,8 44,4	②
161.16.0560.890.11.1503 161.16.0560.891.21.1503	50	664	479	55	610	510	20	15,5	14	4	558	562	46	46	9	9	650	5	130	+2,5	-0,5	46	14,4 22,2	28,8 44,4	③
161.16.0630.890.11.1503 161.16.0630.891.21.1503	61	742,8	543	55	682	578	20	17,5	16	4	628	632	46	46	9	9	726	6	121	+3,0	-0,6	46	17,3 26,6	34,6 53,2	④

Bearings with internal gear

162.16.0400.890.11.1503 162.16.0400.891.21.1503	31	475	304	55	448	352	16	13,5	12	2	402	398	46	46	9	9	308	4	77	-2,0	-	46	11,5 17,7	23,0 35,5	①
162.16.0450.890.11.1503 162.16.0450.891.21.1503	40	531	345	55	500	400	16	15,5	14	2	452	448	46	46	9	9	350	5	70	-2,5	-	46	14,4 22,2	28,8 44,4	②
162.16.0560.890.11.1503 162.16.0560.891.21.1503	49	641	455	55	610	510	20	15,5	14	4	562	558	46	46	9	9	460	5	92	-2,5	-	46	14,4 22,2	28,8 44,4	③
162.16.0630.890.11.1503 162.16.0630.891.21.1503	59	717	516	55	682	578	20	17,5	16	4	632	628	46	46	9	9	522	6	87	-3,0	-	46	17,3 26,6	34,6 53,2	④

Gear normalized

Gear quenched and tempered

Static limiting load curves

—— Raceway - - - Bolts

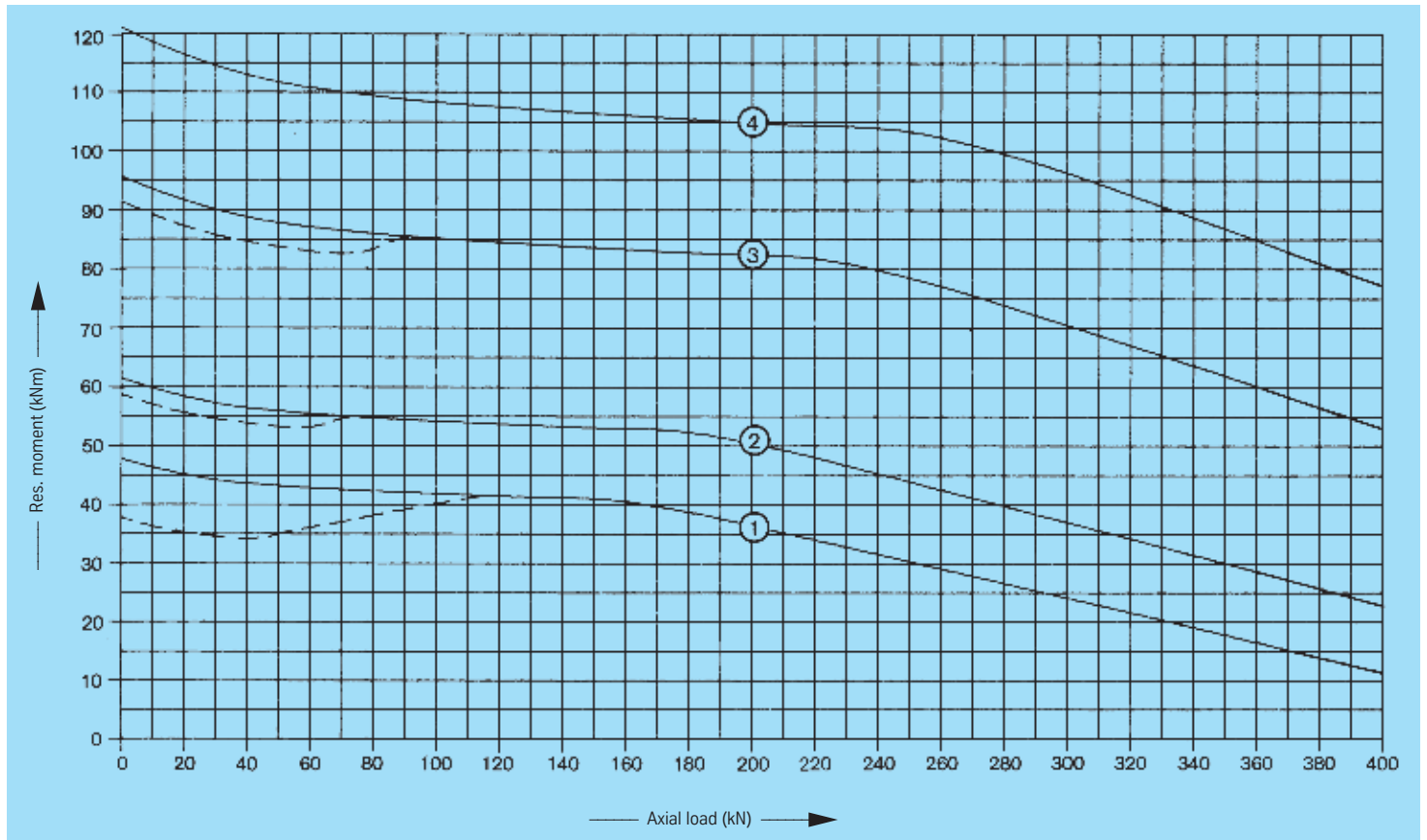

Standard series RD 800



Rothe Erde
Slewing Bearings

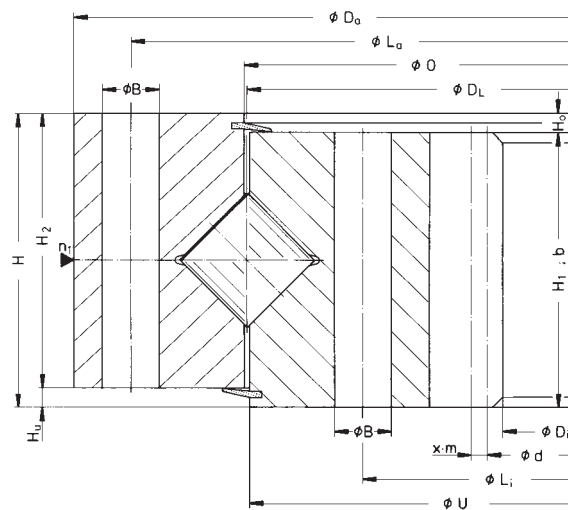
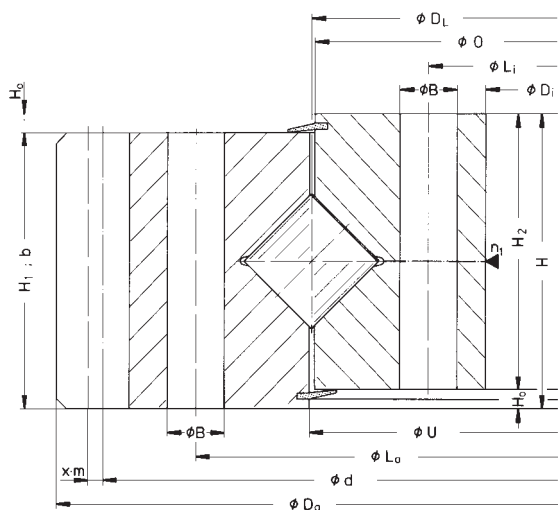

Service life curves · 30,000 revolutions

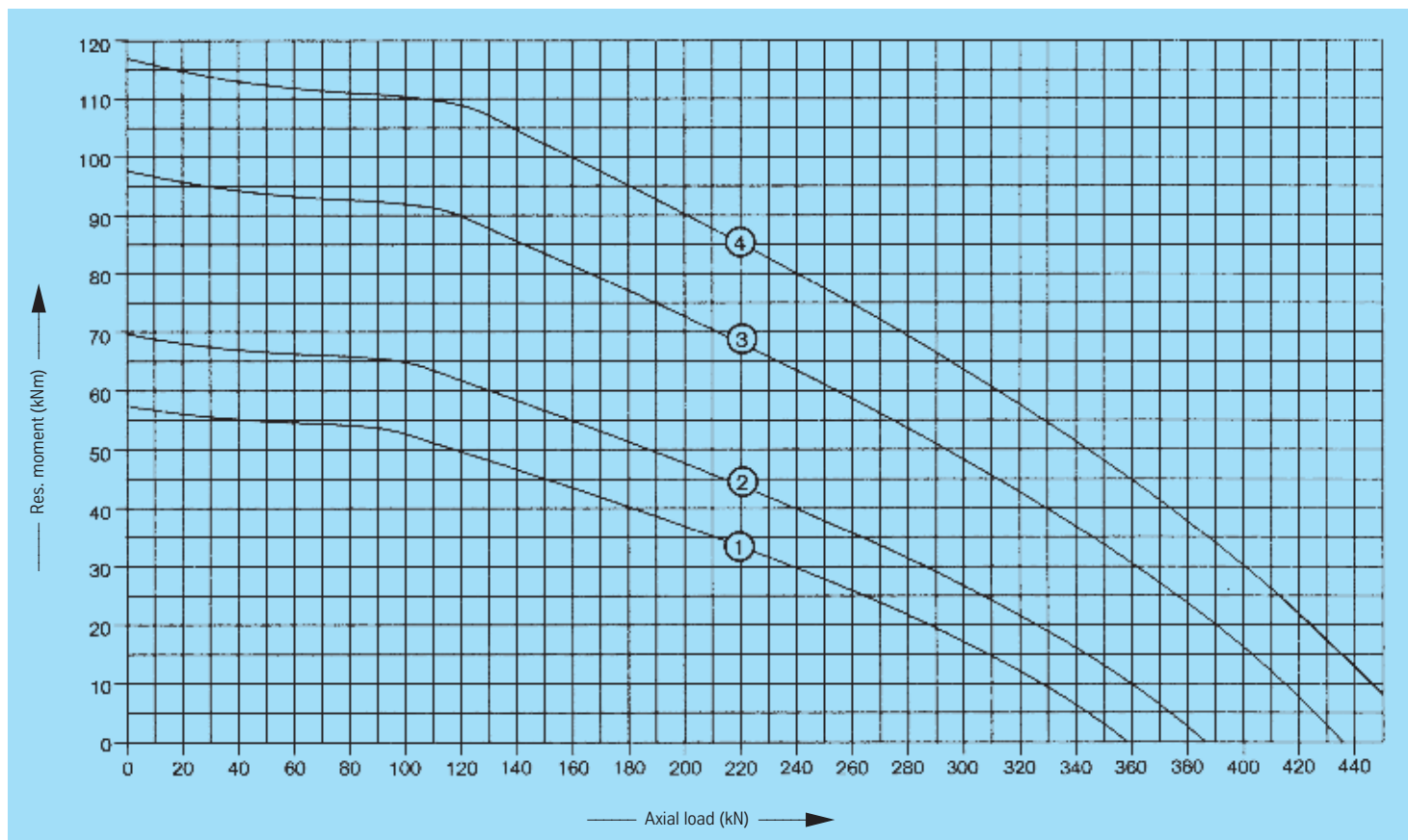

Standard series RD 800



Rothe Erde
Slewing Bearings

Bearings with external gear

Drawing No. Roller track dia. D_t [mm]	Weight [kg]	Outer diameter (O.D.) D_o [mm]	Inner diameter (I.D.) D_i [mm]	Overall height H [mm]	External bolt circle dia. L_e [mm]	Internal bolt circle dia. L_i [mm]	Number of bolt holes per hole circle n	Bolt hole diameter B [mm]	Bolt size M [mm]	Number of grease nipples n_1	Diameter O [mm]	Diameter U [mm]	Ring height H_1 [mm]	Ring height H_2 [mm]	Distance at bottom Outer ring/inner ring H_b [mm]	Distance at top Outer ring/inner ring H_o [mm]	Gear P.C.D. d [mm]	Module m [mm]	Number of teeth z	Addendum modification sign per DIN 3960 October, 1976 $x \cdot m$ [mm]	Addendum reduction $k \cdot m$ [mm]	Tooth width b [mm]	Permissible tangential forces, normal [kN]	Permissible tangential forces, maximum [kN]	Curves
161.20.0450.890.11.1503 161.20.0450.891.21.1503	49	562,8	364	62	505	395	16	15,5	14	2	448	452	53	53	9	9	546	6	91	+3,0	-0,6	53	19,9	39,8	5
161.20.0560.890.11.1503 161.20.0560.891.21.1503	62	676,8	474	62	615	505	20	15,5	14	4	558	562	53	53	9	9	660	6	110	+3,0	-0,6	53	19,9	39,8	6
161.20.0630.890.11.1503 161.20.0630.891.21.1503	76	758,4	538	62	687	573	20	17,5	16	4	628	632	53	53	9	9	736	8	92	+4,0	-0,8	53	26,6	53,2	7
161.20.0710.890.11.1503 161.20.0710.891.21.1503	85	838,4	618	62	767	653	24	17,5	16	4	708	712	53	53	9	9	816	8	102	+4,0	-0,8	53	26,6	53,2	8

Bearings with internal gear

162.20.0450.890.11.1503 162.20.0450.891.21.1503	48	536	336	62	505	395	16	15,5	14	2	452	448	53	53	9	9	342	6	57	-3,0	-	53	19,9	39,8	5
162.20.0560.890.11.1503 162.20.0560.891.21.1503	60	646	444	62	615	505	20	15,5	14	4	562	558	53	53	9	9	450	6	75	-3,0	-	53	19,9	39,8	6
162.20.0630.890.11.1503 162.20.0630.891.21.1503	75	722	496	62	687	573	20	17,5	16	4	632	628	53	53	9	9	504	8	63	-4,0	-	53	26,6	53,2	7
162.20.0710.890.11.1503 162.20.0710.891.21.1503	84	802	576	62	767	653	24	17,5	16	4	712	708	53	53	9	9	584	8	73	-4,0	-	53	26,6	53,2	8

Gear normalized

Gear quenched and tempered

Static limiting load curves

—— Raceway - - - Bolts

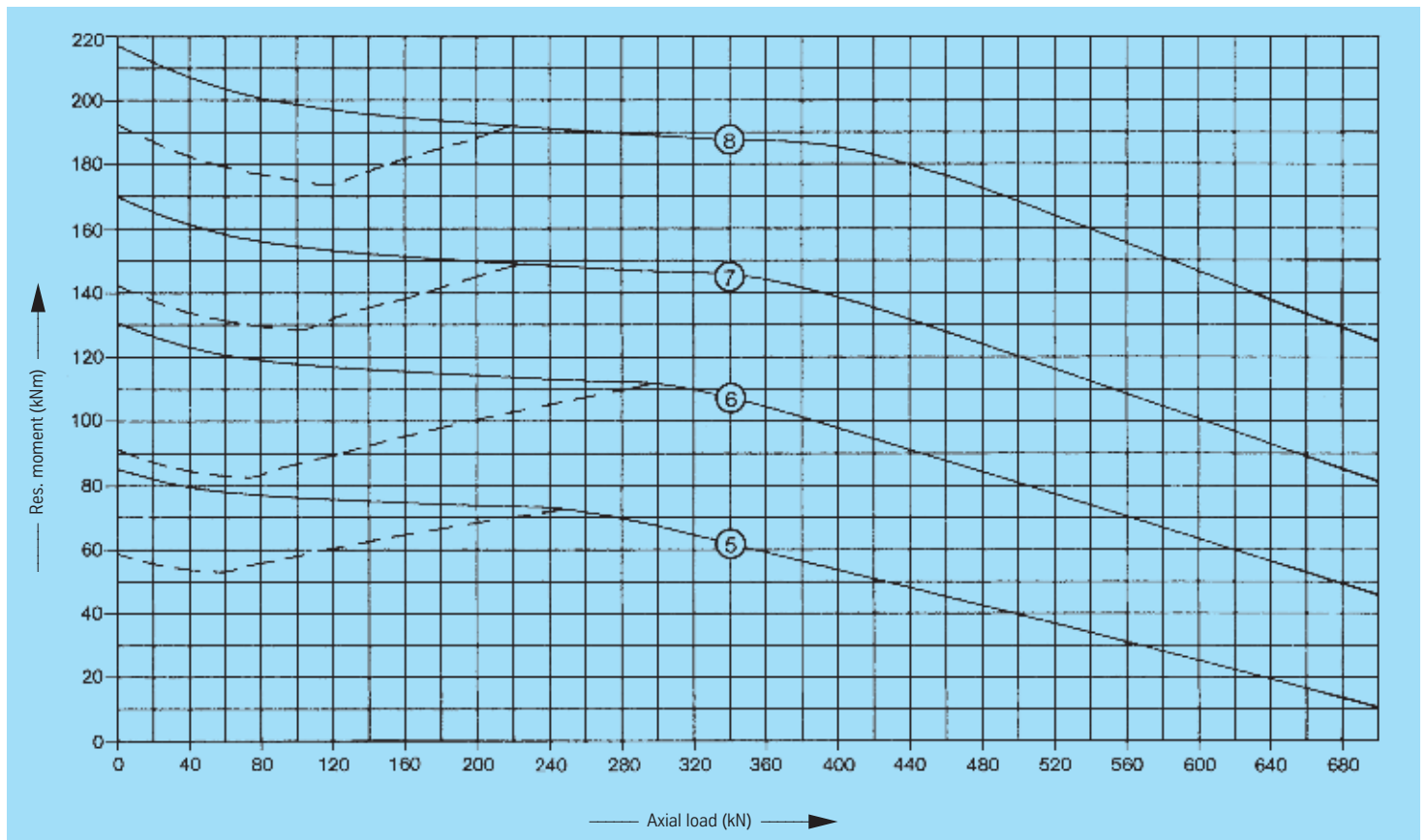

Standard series RD 800



Rothe Erde
Slewing Bearings

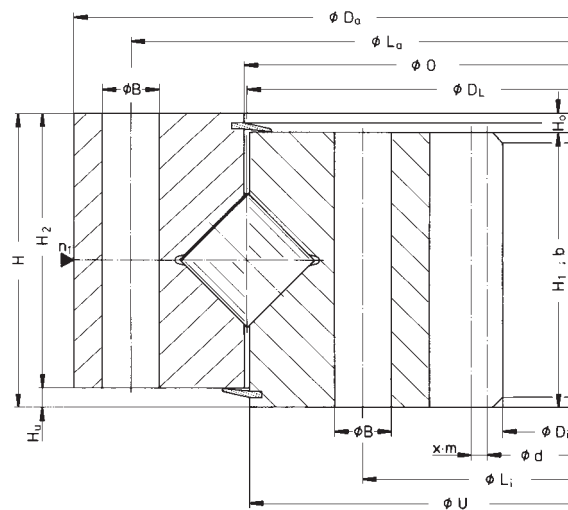
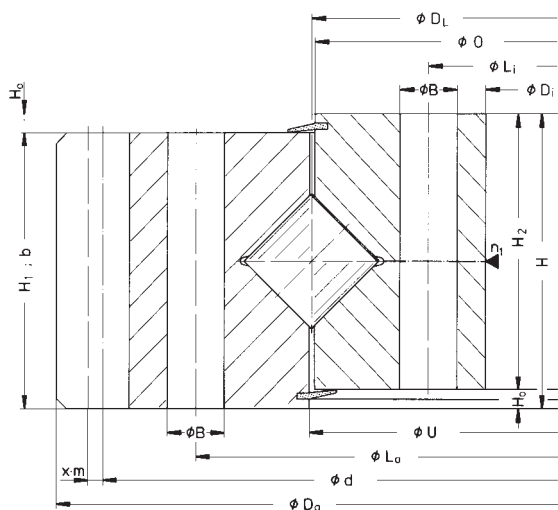

Service life curves · 30,000 revolutions

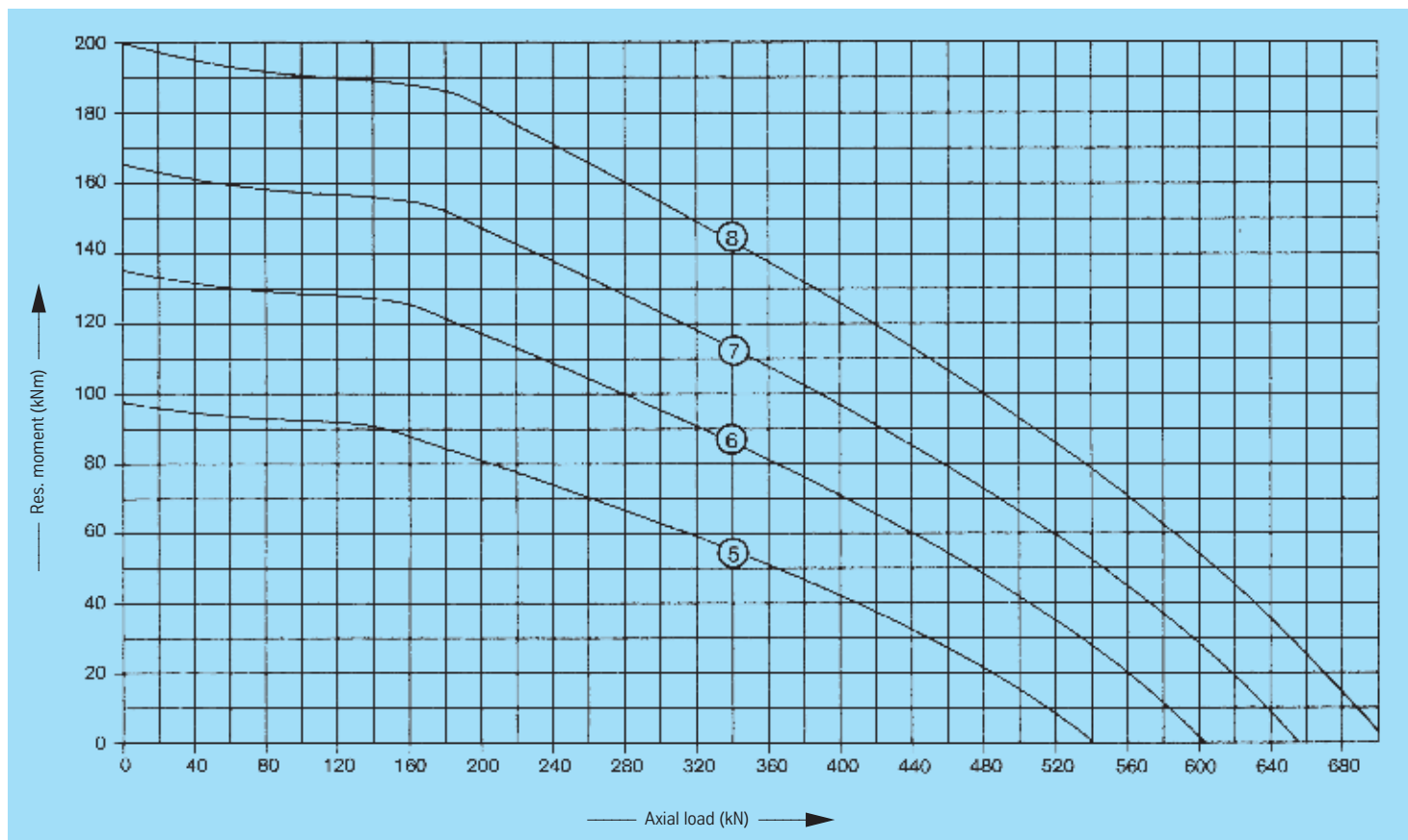

Standard series RD 800



Rothe Erde
Slewing Bearings

Bearings with external gear

Drawing No. Roller track dia. D_1 [mm]	Weight [kg]	Outer diameter (O.D.) D_o [mm]	Inner diameter (I.D.) D_i [mm]	Overall height H [mm]	External bolt circle dia. L_e [mm]	Internal bolt circle dia. L_i [mm]	Number of bolt holes per hole circle n	Bolt hole diameter B [mm]	Bolt size M [mm]	Number of grease nipples n_1	Diameter O [mm]	Diameter U [mm]	Ring height H_1 [mm]	Ring height H_2 [mm]	Distance at bottom Outer ring/inner ring H_b [mm]	Distance at top Outer ring/inner ring H_o [mm]	Gear P.C.D. d [mm]	Module m [mm]	Number of teeth z	Addendum modification sign per DIN 3960 October, 1976 $x \cdot m$ [mm]	Addendum reduction $k \cdot m$ [mm]	Tooth width b [mm]	Permissible tangential forces, normal [kN]	Permissible tangential forces, maximum [kN]	Curves
161.25.0764.890.11.1503 161.25.0764.891.21.1503	116	892,8	662	73	830	698	24	17,5	16	4	762	766	64	64	9	9	876	6	146	+3,0	-0,6	64	24,1 37,1	48,2 74,2	9
161.25.0886.890.11.1503 161.25.0886.891.21.1503	144	1030,4	784	73	952	820	30	17,5	16	5	884	888	64	64	9	9	1008	8	126	+4,0	-0,8	64	32,1 49,4	64,2 98,8	10
161.25.0980.890.11.1503 161.25.0980.891.21.1503	155	1118,4	878	73	1046	914	30	17,5	16	5	978	982	64	64	9	9	1096	8	137	+4,0	-0,8	64	32,1 49,4	64,2 98,8	11
161.25.1077.890.11.1503 161.25.1077.891.21.1503	178	1228	975	73	1143	1011	36	17,5	16	6	1075	1079	64	64	9	9	1200	10	120	+5,0	-1,0	64	40,1 61,8	80,2 123,6	12

Bearings with internal gear

162.25.0764.890.11.1503 162.25.0764.891.21.1503	113	866	636	73	830	698	24	17,5	16	4	766	762	64	64	9	9	642	6	107	-3,0	-	64	24,1 37,1	48,2 74,2	9
162.25.0886.890.11.1503 162.25.0886.891.21.1503	138	988	744	73	952	820	30	17,5	16	5	888	884	64	64	9	9	752	8	94	-4,0	-	64	32,1 49,4	64,2 98,8	10
162.25.0980.890.11.1503 162.25.0980.891.21.1503	152	1082	840	73	1046	914	30	17,5	16	5	982	978	64	64	9	9	848	8	106	-4,0	-	64	32,1 49,4	64,2 98,8	11
162.25.1077.890.11.1503 162.25.1077.891.21.1503	177	1179	920	73	1143	1011	36	17,5	16	6	1079	1075	64	64	9	9	930	10	93	-5,0	-	64	40,1 61,8	80,2 123,6	12

Gear normalized

Gear quenched and tempered

Static limiting load curves

—— Raceway - - - Bolts

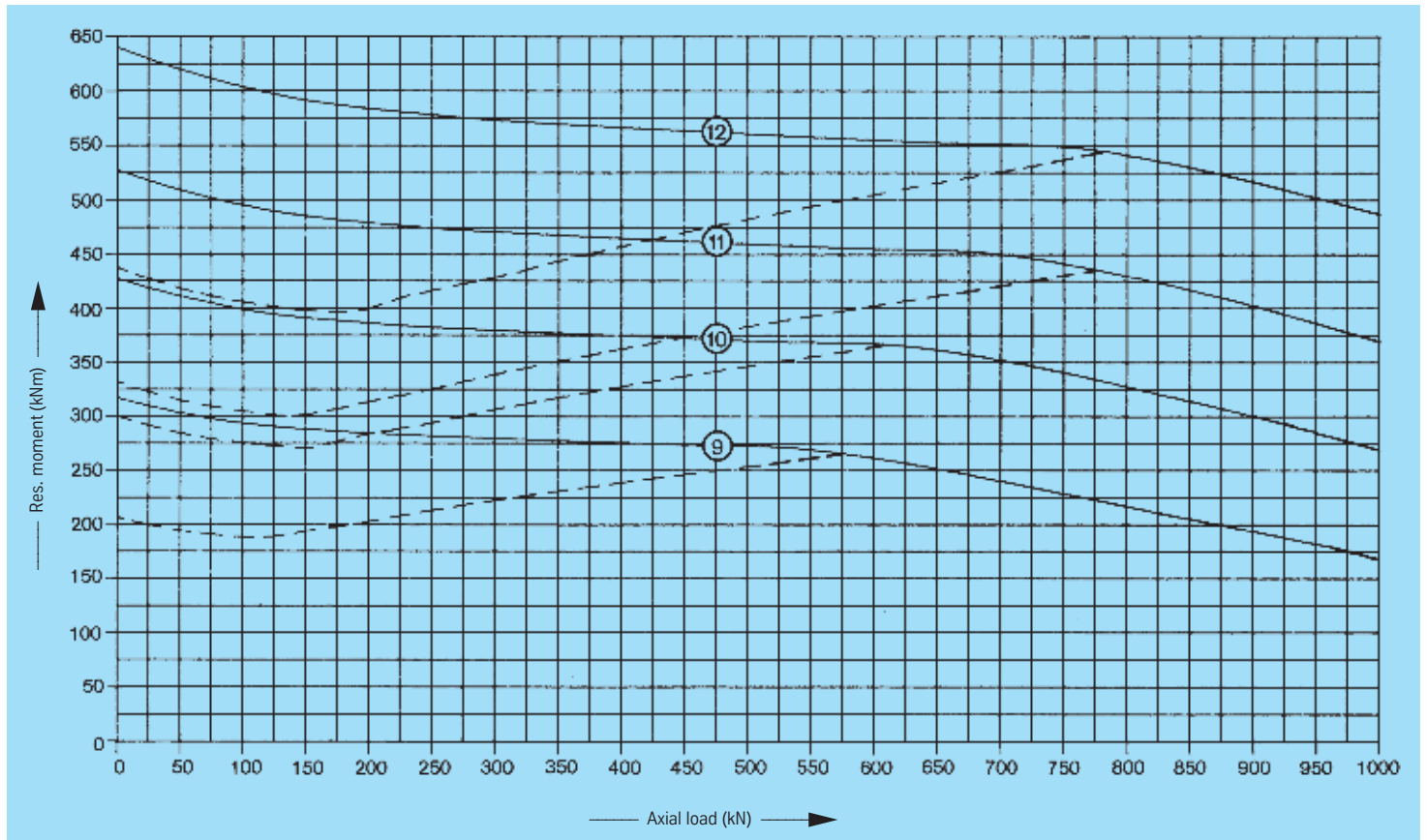

Standard series RD 800



Rothe Erde
Slewing Bearings

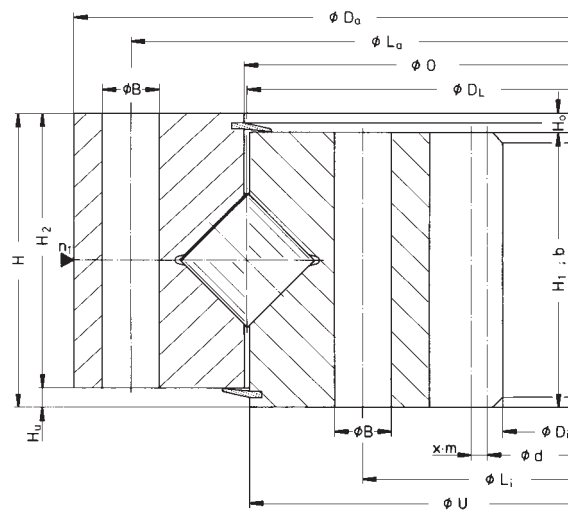
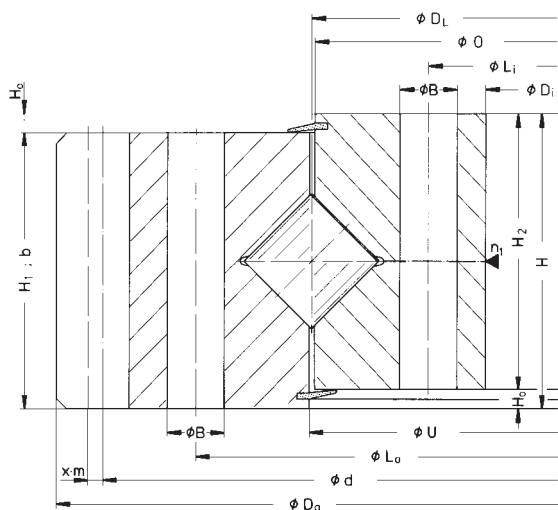

Service life curves · 30,000 revolutions

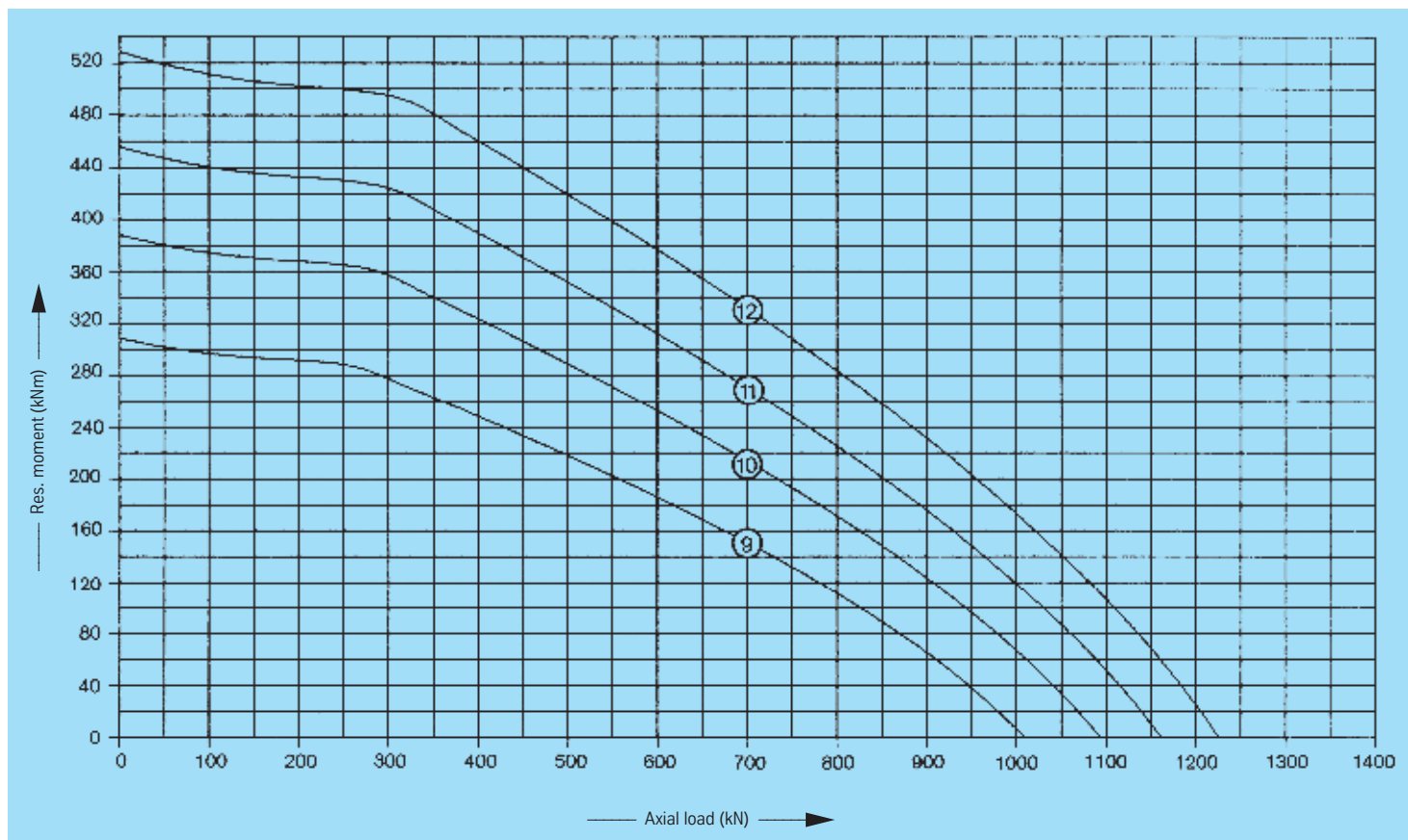

Standard series RD 800



Rothe Erde
Slewing Bearings

Bearings with external gear

Drawing No. Roller track dia. D_t [mm]	Weight [kg]	Outer diameter (O.D.) D_o [mm]	Inner diameter (I.D.) D_i [mm]	Overall height H [mm]	External bolt circle dia. L_e [mm]	Internal bolt circle dia. L_i [mm]	Number of bolt holes per hole circle n	Bolt hole diameter B [mm]	Bolt size M [mm]	Number of grease nipples n_1	Diameter O [mm]	Diameter U [mm]	Ring height H_1 [mm]	Ring height H_2 [mm]	Distance at bottom Outer ring/inner ring H_b [mm]	Distance at top Outer ring/inner ring H_o [mm]	Gear P.C.D. d [mm]	Module m [mm]	Number of teeth z	Addendum modification sign per DIN 3960 October, 1976 $x \cdot m$ [mm]	Addendum reduction $k \cdot m$ [mm]	Tooth width b [mm]	Permissible tangential forces, normal [kN]	Permissible tangential forces, maximum [kN]	Curves
161.25.1120.890.11.1503 161.25.1120.891.21.1503	195	1278	1008	73	1188	1052	36	22	20	6	1118	1122	64	64	9	9	1250	10	125	+5,0	-1,0	64	40,1 61,8	80,2 123,6	13
161.25.1180.890.11.1503 161.25.1180.891.21.1503	206	1338	1068	73	1248	1112	36	22	20	6	1178	1182	64	64	9	9	1310	10	131	+5,0	-1,0	64	40,1 61,8	80,2 123,6	14
161.25.1250.890.11.1503 161.25.1250.891.21.1503	216	1408	1138	73	1318	1182	40	22	20	8	1248	1252	64	64	9	9	1380	10	138	+5,0	-1,0	64	40,1 61,8	80,2 123,6	15
161.25.1320.890.11.1503 161.25.1320.891.21.1503	247	1497,6	1208	73	1388	1252	42	22	20	6	1318	1322	64	64	9	9	1464	12	122	+6,0	-1,2	64	48,2 74,2	96,4 148,4	16

Bearings with internal gear

162.25.1120.890.11.1503 162.25.1120.891.21.1503	192	1232	960	73	1188	1052	36	22	20	6	1122	1118	64	64	9	9	970	10	97	-5,0	-	64	40,1 61,8	80,2 123,6	13
162.25.1180.890.11.1503 162.25.1180.891.21.1503	202	1292	1020	73	1248	1112	36	22	20	6	1182	1178	64	64	9	9	1030	10	103	-5,0	-	64	40,1 61,8	80,2 123,6	14
162.25.1250.890.11.1503 162.25.1250.891.21.1503	213	1362	1090	73	1318	1182	40	22	20	8	1252	1248	64	64	9	9	1100	10	110	-5,0	-	64	40,1 61,8	80,2 123,6	15
162.25.1320.890.11.1503 162.25.1320.891.21.1503	240	1432	1140	73	1388	1252	40	22	20	6	1322	1318	64	64	9	9	1152	12	96	-6,0	-	64	48,2 74,2	96,4 148,4	16

Gear normalized

Gear quenched and tempered

Static limiting load curves

—— Raceway - - - Bolts

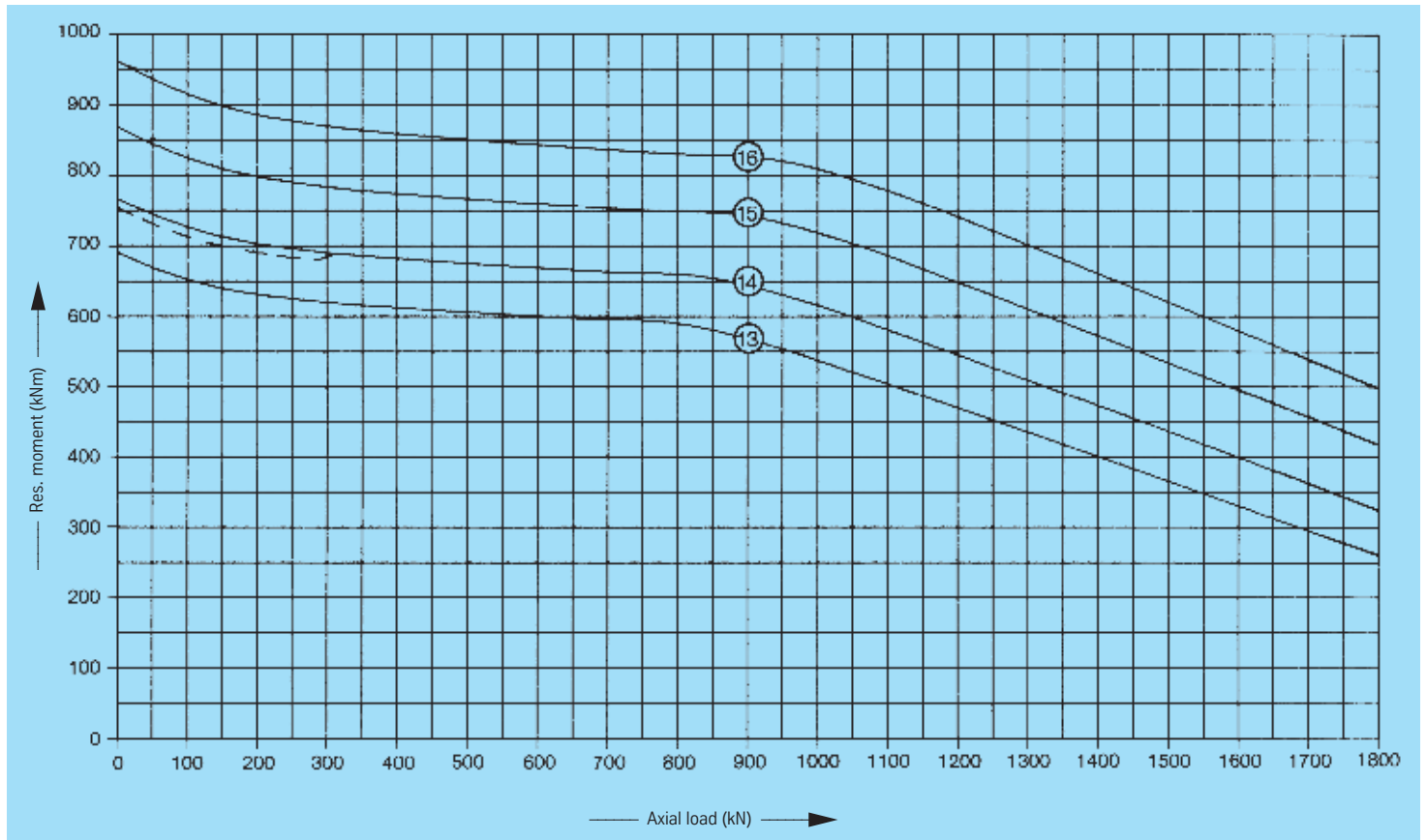

Standard series RD 800



Rothe Erde
Slewing Bearings

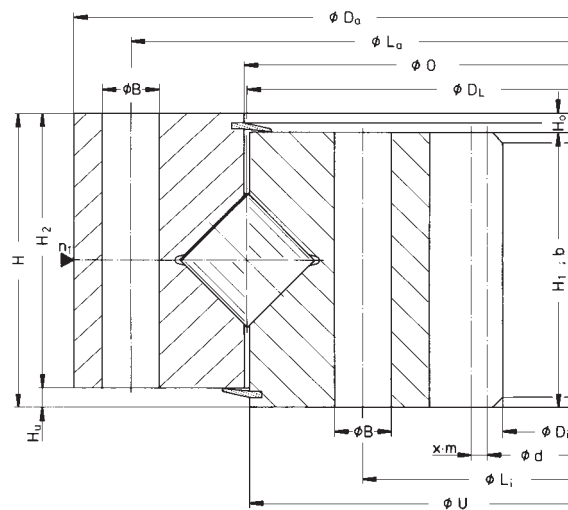
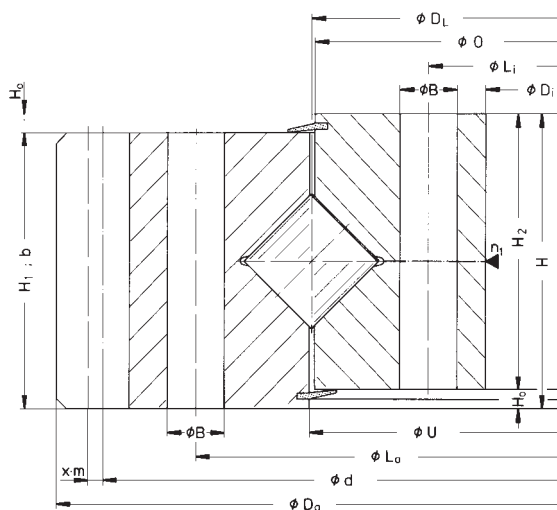

Service life curves · 30,000 revolutions

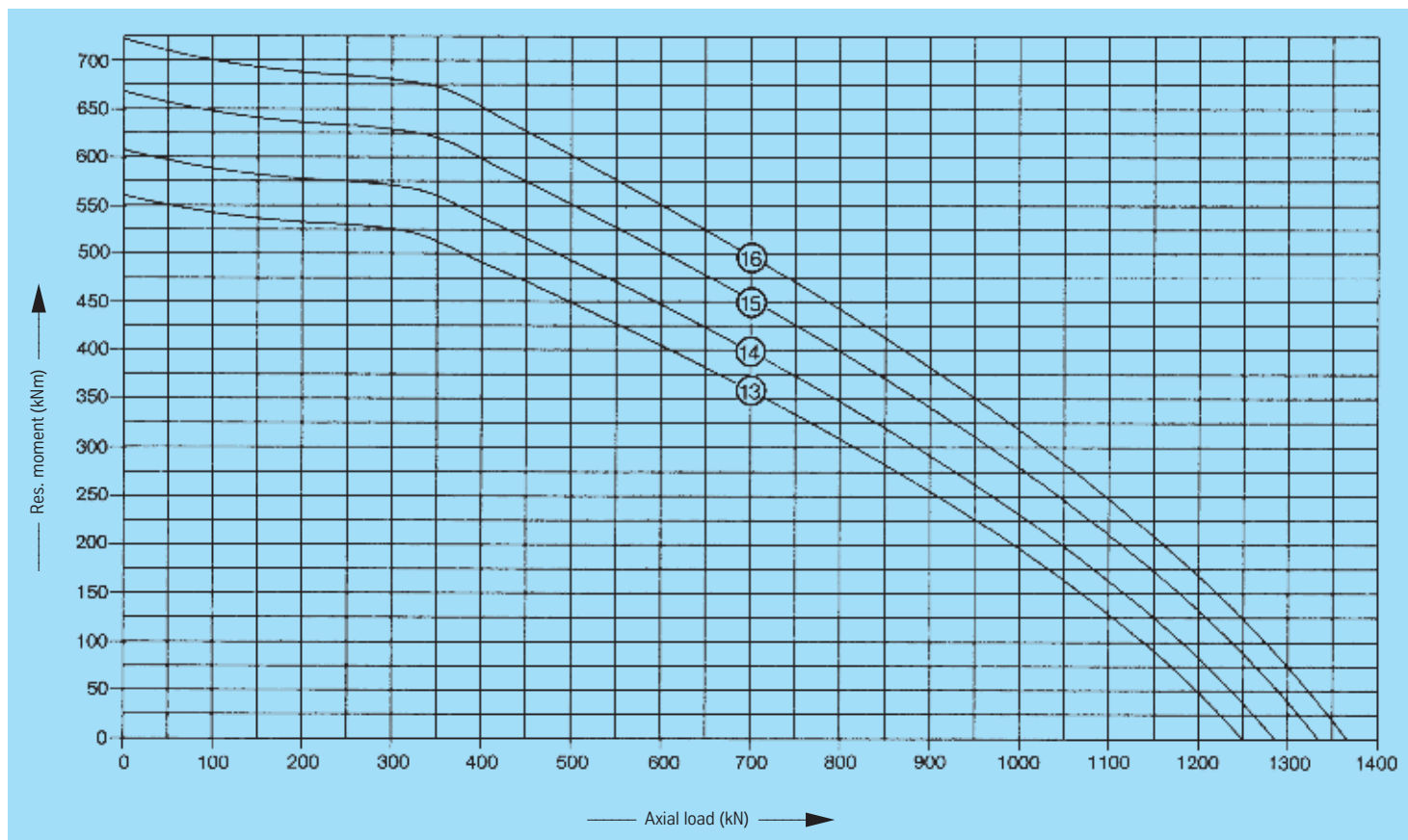

Standard series RD 800



Rothe Erde
Slewing Bearings

Bearings with external gear

Drawing No. Roller track dia. D_1 [mm]	Weight [kg]	Outer diameter (O.D.) D_o [mm]	Inner diameter (I.D.) D_i [mm]	Overall height H [mm]	External bolt circle dia. L_e [mm]	Internal bolt circle dia. L_i [mm]	Number of bolt holes per hole circle n	Bolt hole diameter B [mm]	Bolt size M [mm]	Number of grease nipples n_1	Diameter O [mm]	Diameter U [mm]	Ring height H_1 [mm]	Ring height H_2 [mm]	Distance at bottom Outer ring/inner ring H_b [mm]	Distance at top Outer ring/inner ring H_o [mm]	Gear P.C.D. d [mm]	Module m [mm]	Number of teeth z	Addendum modification sign per DIN 3960 October, 1976 $x \cdot m$ [mm]	Addendum reduction $k \cdot m$ [mm]	Tooth width b [mm]	Permissible tangential forces, normal [kN]	Permissible tangential forces, maximum [kN]	Curves
161.28.1400.890.11.1503 161.28.1400.891.21.1503	332	1593,6	1266	80	1482	1318	36	26	24	6	1398	1402	71	71	9	9	1560	12	130	+6,0	-1,2	71	53,5 107,0 78,2 156,4	17	
161.28.1500.890.11.1503 161.28.1500.891.21.1503	349	1689,6	1366	80	1582	1418	40	26	24	8	1498	1502	71	71	9	9	1656	12	138	+6,0	-1,2	71	53,5 107,0 78,2 156,4	18	
161.28.1600.890.11.1503 161.28.1600.891.21.1503	388	1803,2	1466	80	1682	1518	40	26	24	8	1598	1602	71	71	9	9	1764	14	126	+7,0	-1,4	71	62,4 124,8 91,2 182,4	19	
161.28.1700.890.11.1503 161.28.1700.891.21.1503	431	1915,2	1566	80	1782	1618	44	26	24	11	1698	1702	71	71	9	9	1876	14	134	+7,0	-1,4	71	62,4 124,8 91,2 182,4	20	

Bearings with internal gear

162.28.1400.890.11.1503 162.28.1400.891.21.1503	330	1534	1200	80	1482	1318	36	26	24	6	1402	1398	71	71	9	9	1212	12	101	-6,0	-	71	53,5 107,0 78,2 156,4	17
162.28.1500.890.11.1503 162.28.1500.891.21.1503	343	1634	1308	80	1582	1418	40	26	24	8	1502	1498	71	71	9	9	1320	12	110	-6,0	-	71	53,5 107,0 78,2 156,4	18
162.28.1600.890.11.1503 162.28.1600.891.21.1503	391	1734	1386	80	1682	1518	40	26	24	8	1602	1598	71	71	9	9	1400	14	100	-7,0	-	71	62,4 124,8 91,2 182,4	19
162.28.1700.890.11.1503 162.28.1700.891.21.1503	398	1834	1498	80	1782	1618	44	26	24	10	1702	1698	71	71	9	9	1512	14	108	-7,0	-	71	62,4 124,8 91,2 182,4	20

Gear normalized
Gear quenched and tempered

Static limiting load curves

—— Raceway - - - Bolts

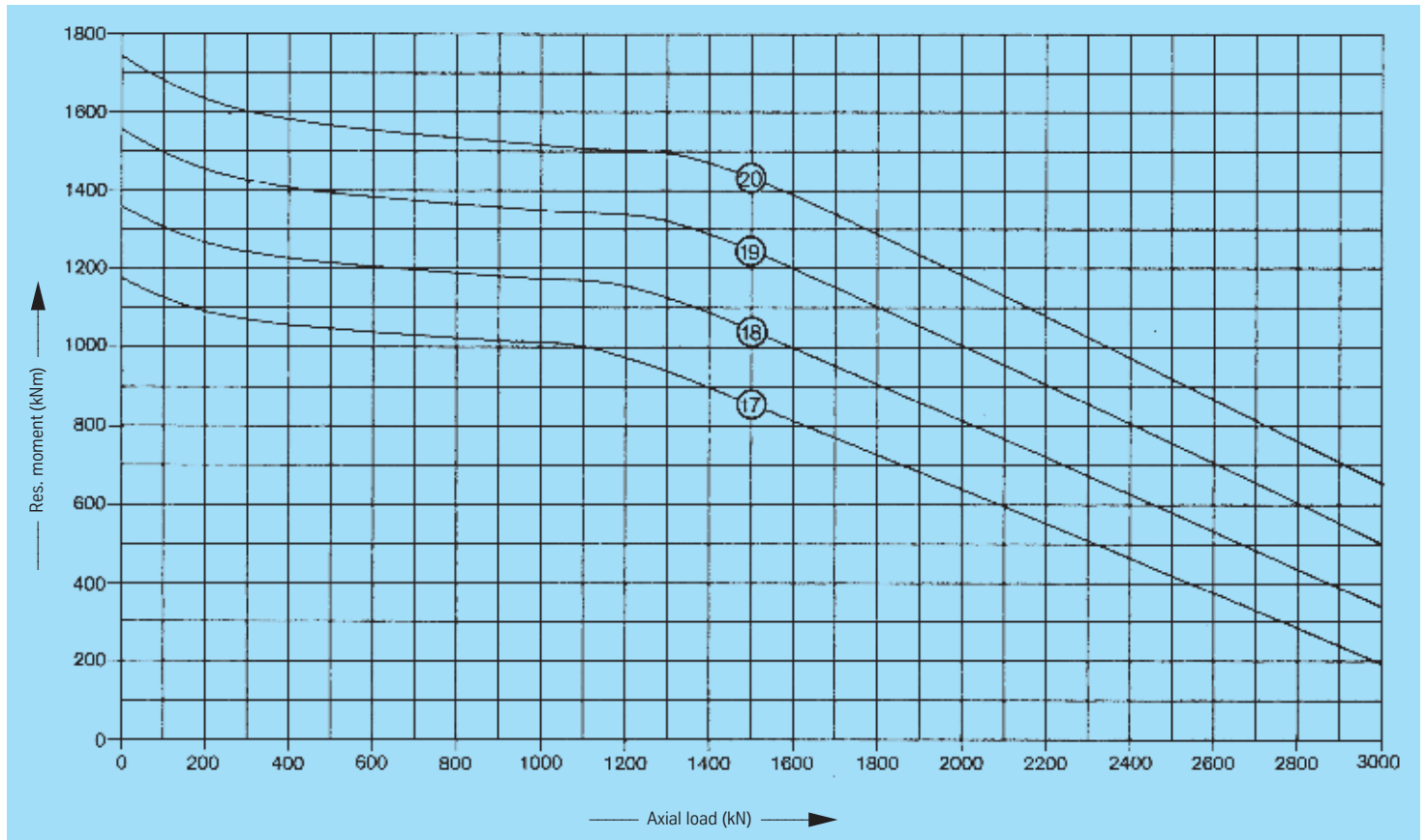

Standard series RD 800



Rothe Erde
Slewing Bearings

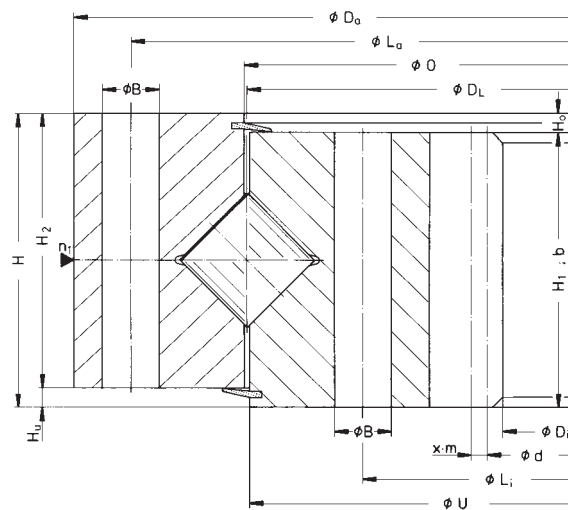
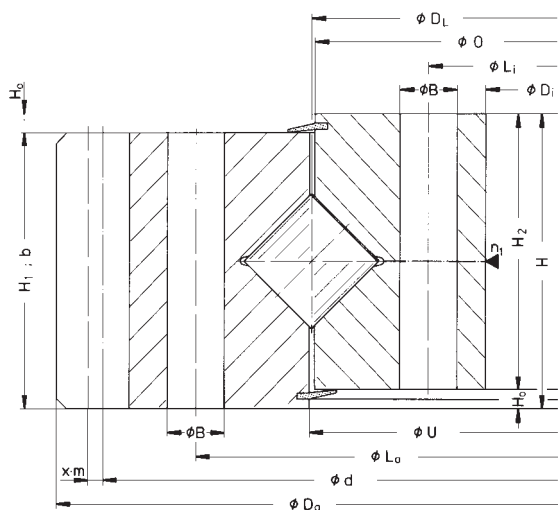

Service life curves · 30,000 revolutions

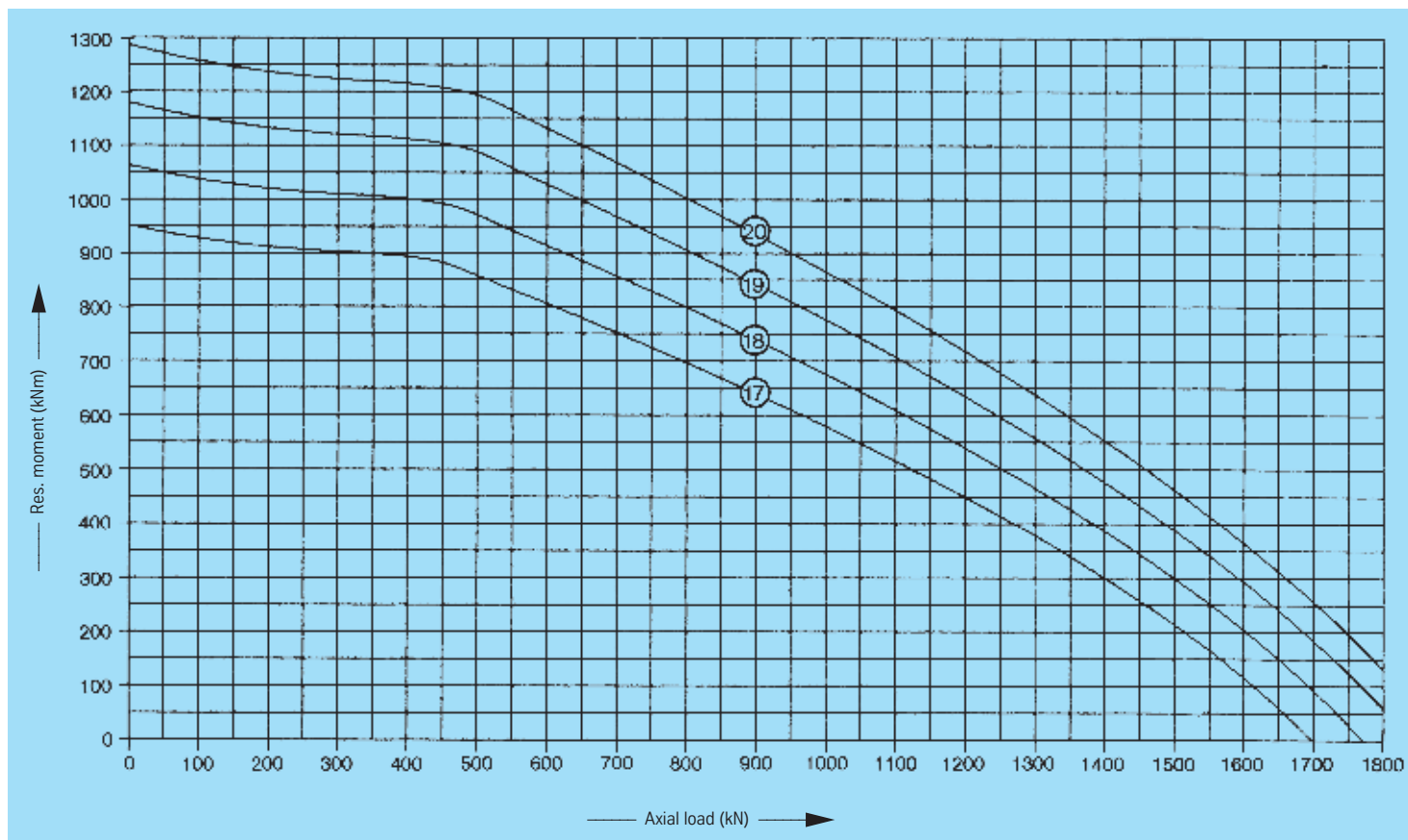

Standard series RD 800



Rothe Erde
Slew Bearings

Bearings with external gear

Drawing No. Roller track dia. D_k [mm]	Weight [kg]	Outer diameter (O.D.) D_o [mm]	Inner diameter (I.D.) D_i [mm]	Overall height H [mm]	External bolt circle dia. L_e [mm]	Internal bolt circle dia. L_i [mm]	Number of bolt holes per hole circle n	Bolt hole diameter B [mm]	Bolt size M [mm]	Number of grease nipples n_1	Diameter O [mm]	Diameter U [mm]	Ring height H_1 [mm]	Ring height H_2 [mm]	Distance at bottom Outer ring/inner ring H_b [mm]	Distance at top Outer ring/inner ring H_o [mm]	Gear P.C.D. d [mm]	Module m [mm]	Number of teeth z	Addendum modification sign per DIN 3960 October, 1976 $x \cdot m$ [mm]	Addendum reduction $k \cdot m$ [mm]	Tooth width b [mm]	Permissible tangential forces, normal [kN]	Permissible tangential forces, maximum [kN]	Curves
161.36.1700.890.11.1503 161.36.1700.891.41.1503	653	1943,2	1529	100	1805	1595	32	33	30	8	1698	1702	90	90	10	10	1904	14	136	+7,0	-1,4	90	79,1 158,2 115,6 231,2	21	
161.36.1800.890.11.1503 161.36.1800.891.41.1503	685	2041,2	1629	100	1905	1695	36	33	30	9	1798	1802	90	90	10	10	2002	14	145	+7,0	-1,4	90	79,1 158,2 115,6 231,2	22	
161.36.1900.890.11.1503 161.36.1900.891.41.1503	721	2139,2	1729	100	2005	1795	36	33	30	9	1898	1902	90	90	10	10	2100	14	150	+7,0	-1,4	90	79,1 158,2 115,6 231,2	23	
161.36.2000.890.11.1503 161.36.2000.891.41.1503	749	2237,2	1829	100	2105	1895	40	33	30	8	1998	2002	90	90	10	10	2198	14	157	+7,0	-1,4	90	79,1 158,2 115,6 231,2	24	

Bearings with internal gear

162.36.1700.890.11.1503 162.36.1700.891.41.1503	636	1871	1456	100	1805	1595	32	33	30	8	1702	1698	90	90	10	10	1470	14	105	-7,0	-	90	79,1 158,2 115,6 231,2	21
162.36.1800.890.11.1503 162.36.1800.891.41.1503	675	1971	1554	100	1905	1695	36	33	30	9	1802	1798	90	90	10	10	1568	14	112	-7,0	-	90	79,1 158,2 115,6 231,2	22
162.36.1900.890.11.1503 162.36.1900.891.41.1503	720	2071	1652	100	2005	1795	36	33	30	9	1902	1898	90	90	10	10	1666	14	119	-7,0	-	90	79,1 158,2 115,6 231,2	23
162.36.2000.890.11.1503 162.36.2000.891.41.1503	731	2171	1764	100	2105	1895	40	33	30	8	2002	1998	90	90	10	10	1778	14	127	-7,0	-	90	79,1 158,2 115,6 231,2	24

Gear normalized

Gear quenched and tempered

Static limiting load curves

—— Raceway - - - Bolts

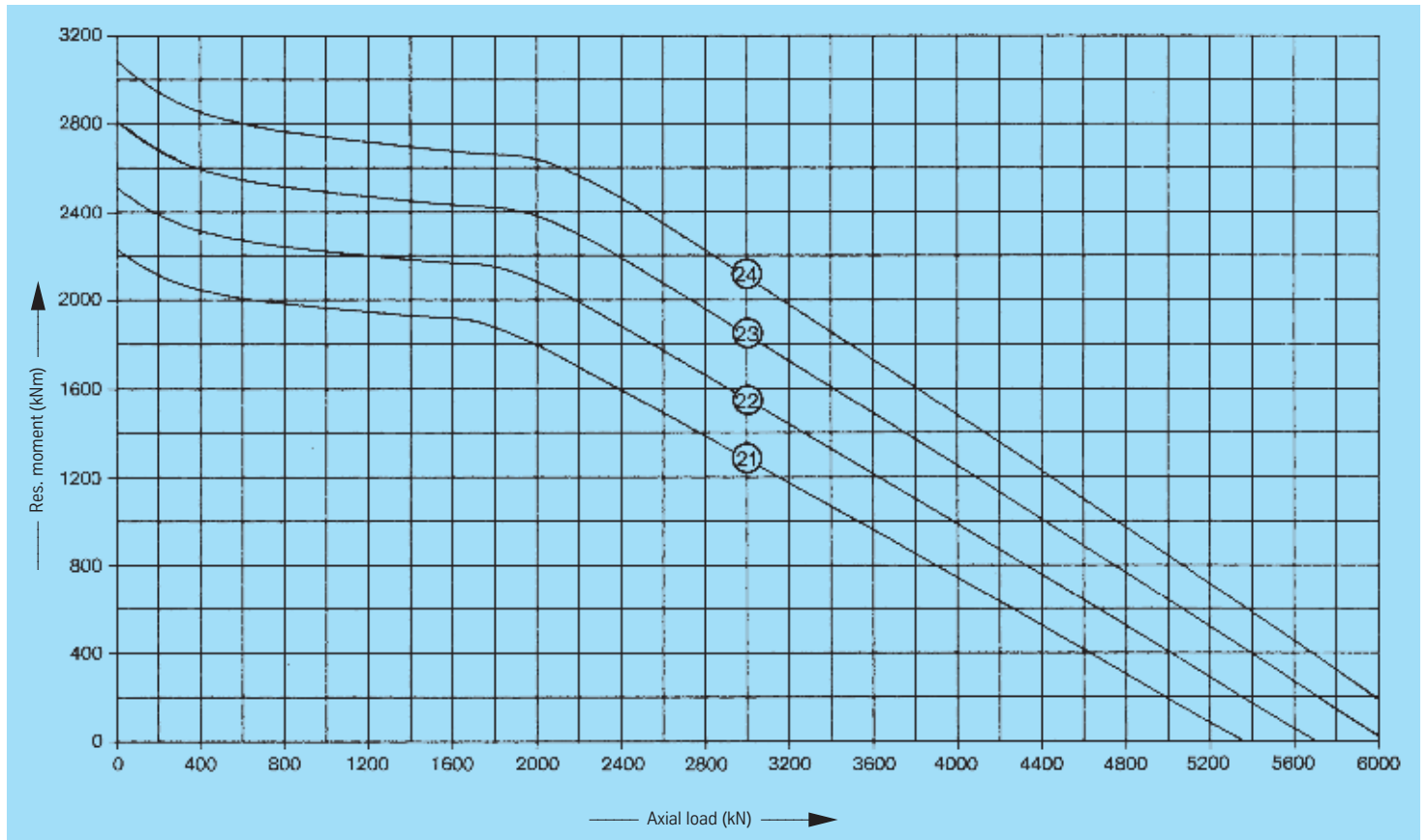

Standard series RD 800



Rothe Erde
Slewing Bearings

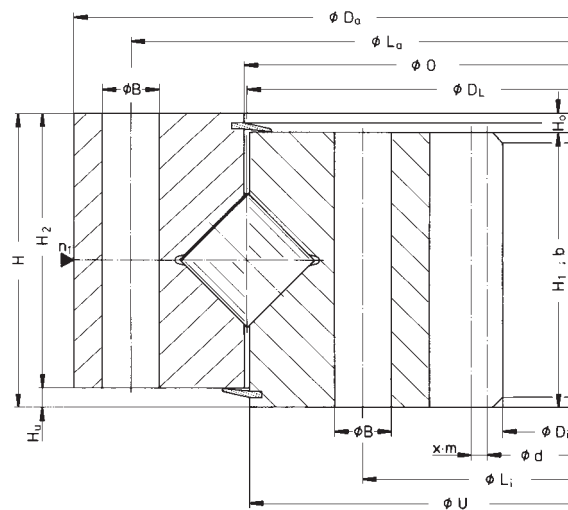
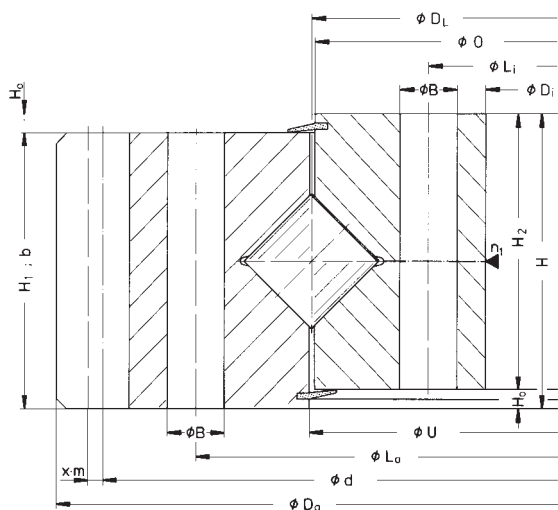

Service life curves · 30,000 revolutions

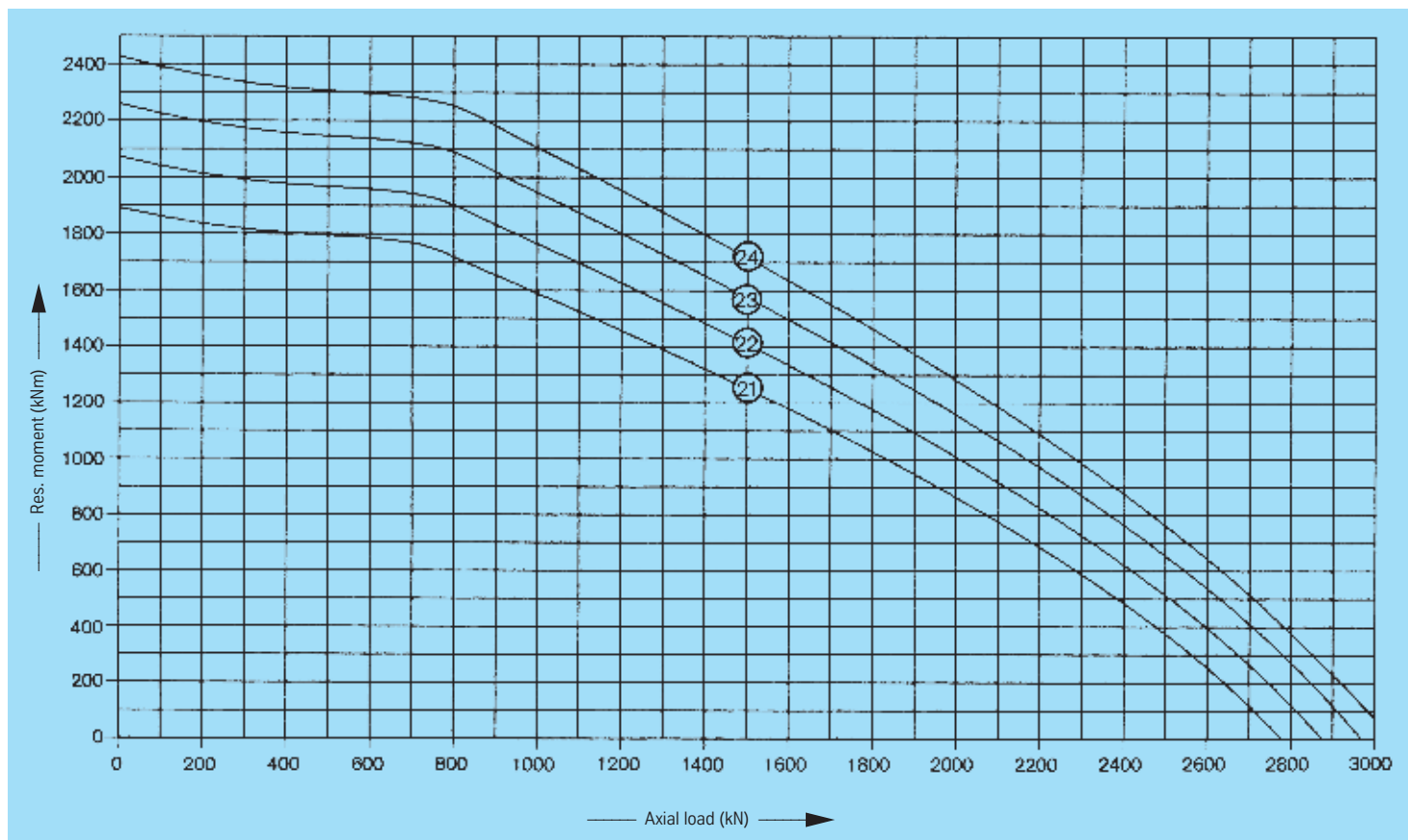

Standard series RD 800



Rothe Erde
Slew Bearings

Bearings with external gear

Drawing No. Roller track dia. D_1 [mm]	Weight [kg]	Outer diameter (O.D.) D_o [mm]	Inner diameter (I.D.) D_i [mm]	Overall height H [mm]	External bolt circle dia. L_e [mm]	Internal bolt circle dia. L_i [mm]	Number of bolt holes per hole circle n	Bolt hole diameter B [mm]	Bolt size M [mm]	Number of grease nipples n_1	Diameter O [mm]	Diameter U [mm]	Ring height H_1 [mm]	Ring height H_2 [mm]	Distance at bottom Outer ring/inner ring H_b [mm]	Distance at top Outer ring/inner ring H_o [mm]	Gear P.C.D. d [mm]	Module m [mm]	Number of teeth z	Addendum modification sign per DIN 3960 October, 1976 $x \cdot m$ [mm]	Addendum reduction $k \cdot m$ [mm]	Tooth width b [mm]	Permissible tangential forces, normal [kN]	Permissible tangential forces, maximum [kN]	Curves
161.40.2000.890.11.1503 161.40.2000.891.41.1503	848	2252,8	1824	108	2110	1890	42	33	30	7	1997	2003	98	98	10	10	2208	16	138	+8,0	-1,6	98	98,4 143,9	196,8 287,8	25
161.40.2128.890.11.1503 161.40.2128.891.41.1503	896	2380,8	1952	108	2238	2018	48	33	30	8	2125	2131	98	98	10	10	2336	16	146	+8,0	-1,6	98	98,4 143,9	196,8 287,8	26
161.40.2240.890.11.1503 161.40.2240.891.41.1503	946	2492,8	2064	108	2350	2130	48	33	30	8	2237	2243	98	98	10	10	2448	16	153	+8,0	-1,6	98	98,4 143,9	196,8 287,8	27
161.40.2368.890.11.1503 161.40.2368.891.41.1503	993	2620,8	2192	108	2478	2258	56	33	30	9	2365	2371	98	98	10	10	2576	16	161	+8,0	-1,6	98	98,4 143,9	196,8 287,8	28

Bearings with internal gear

162.40.2000.890.11.1503 162.40.2000.891.41.1503	832	2176	1744	108	2110	1890	42	33	30	7	2003	1997	98	98	10	10	1760	16	110	-8,0	-	98	98,4 143,9	196,8 287,8	25
162.40.2128.890.11.1503 162.40.2128.891.41.1503	882	2304	1872	108	2238	2018	48	33	30	8	2113	2125	98	98	10	10	1888	16	118	-8,0	-	98	98,4 143,9	196,8 287,8	26
162.40.2240.890.11.1503 162.40.2240.891.41.1503	932	2416	1984	108	2350	2130	48	33	30	8	2243	2237	98	98	10	10	2000	16	125	-8,0	-	98	98,4 143,9	196,8 287,8	27
162.40.2368.890.11.1503 162.40.2368.891.41.1503	980	2544	2112	108	2478	2258	56	33	30	9	2371	2365	98	98	10	10	2128	16	133	-8,0	-	98	98,4 143,9	196,8 287,8	28

Gear normalized

Gear quenched and tempered

Static limiting load curves

—— Raceway - - - Bolts

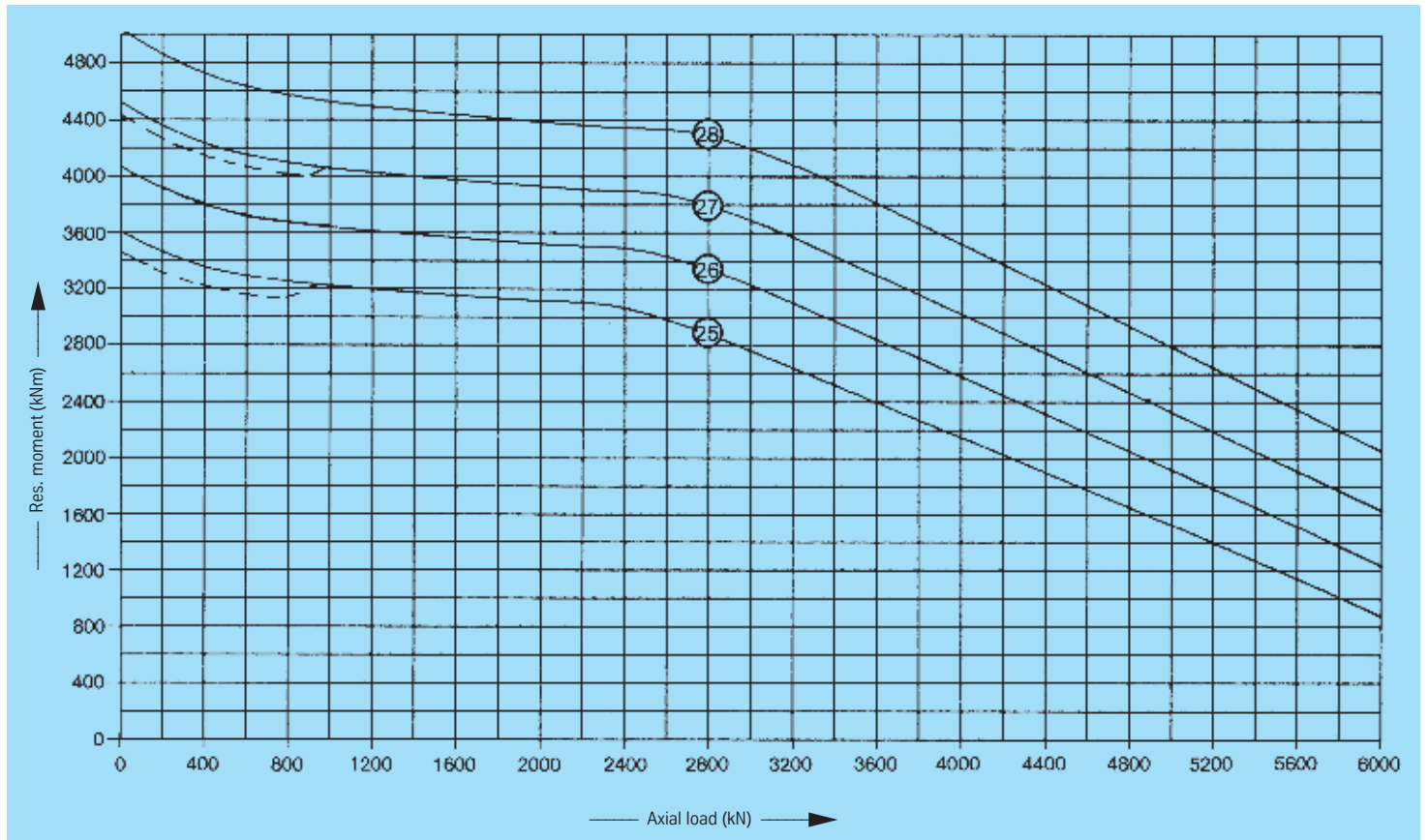

Standard series RD 800



Rothe Erde
Slewing Bearings

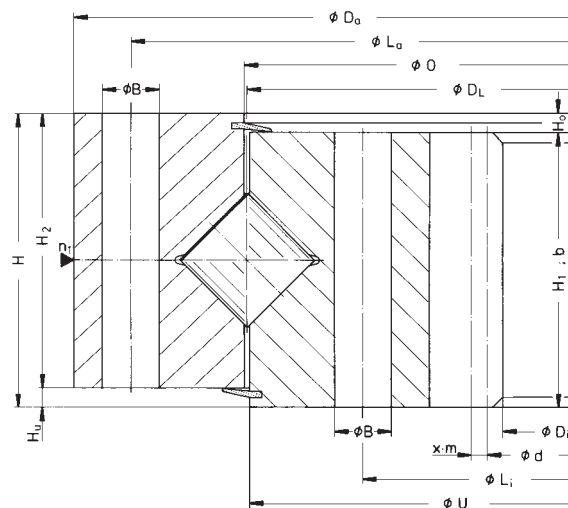
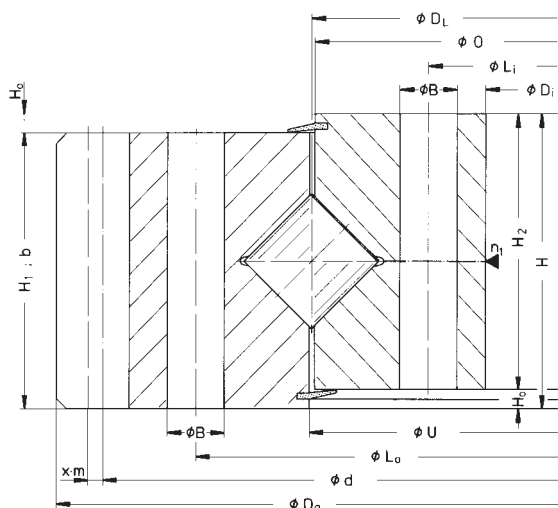

Service life curves · 30,000 revolutions

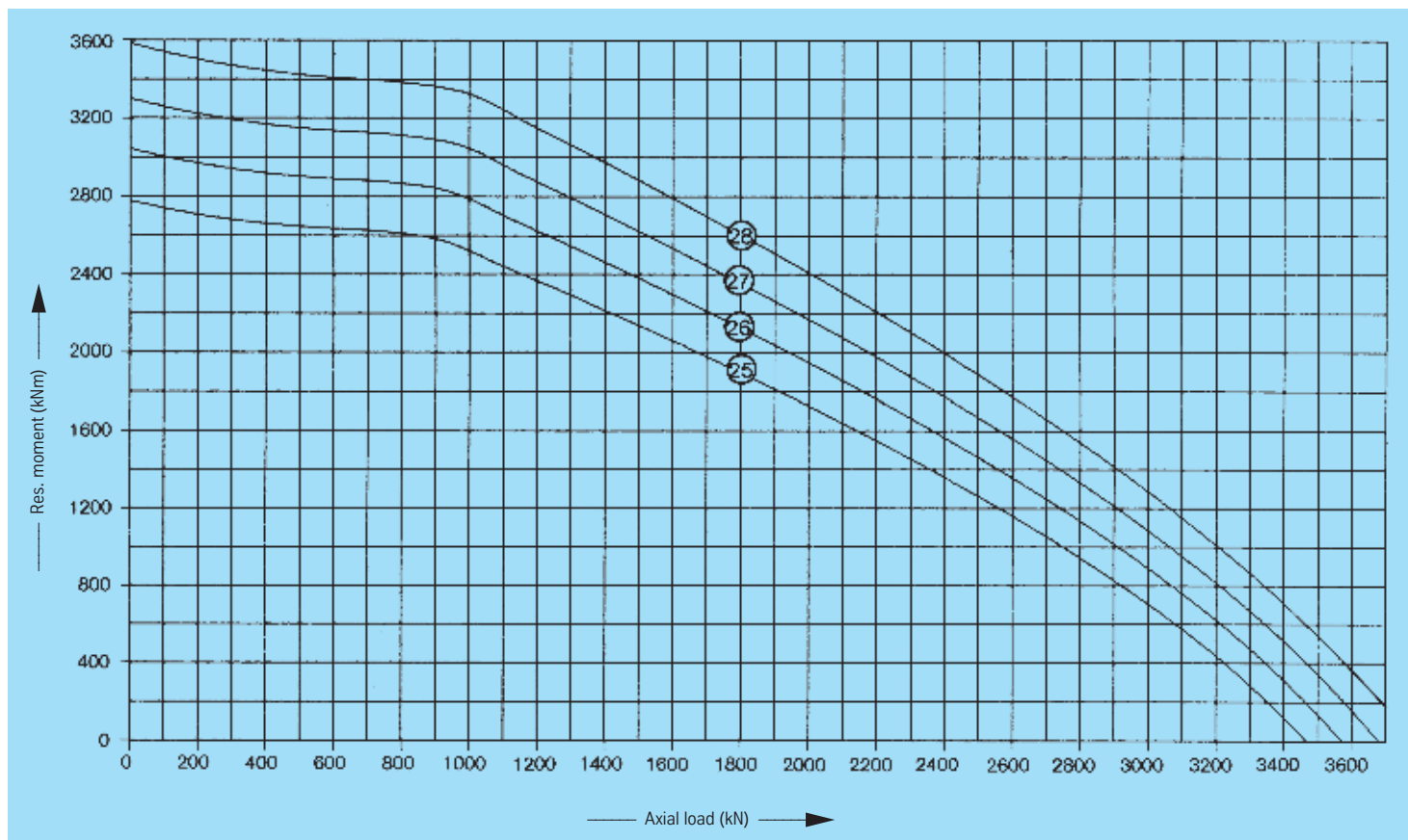

Standard series RD 800



Rothe Erde
Slew Bearings

Bearings with external gear

Drawing No. Roller track dia. D_1 [mm]	Weight [kg]	Outer diameter (O.D.)			Inner diameter (I.D.)			Overall height		External bolt circle dia.		Internal bolt circle dia.		Number of bolt holes per hole circle n	Bolt hole diameter		Bolt size M	Number of grease nipples n_1	Diameter		Ring height H_1	Ring height H_2	Distance at bottom Outer ring/inner ring H_b	Distance at top Outer ring/inner ring H_o	Gear P.C.D.		Module m	Number of teeth z	Addendum modification sign per DIN 3960 October, 1976 $x \cdot m$	Addendum reduction $k \cdot m$	Tooth width b	Permissible tangential forces, normal [kN]	Permissible tangential forces, maximum [kN]	Curves
		D_o [mm]	D_i [mm]	H [mm]	L_e [mm]	L_i [mm]	B [mm]	M [mm]	O [mm]	U [mm]	d [mm]	m [mm]																						
161.45.2240.890.11.1503 161.45.2240.891.41.1503	1122	2516,4	2057	119	2357	2123	48	33	30	8	2237	2243	109	109	10	10	2466	18	137	+9,0	-1,8	109	123,2	246,4	180,0	360,0	29							
161.45.2366.890.11.1503 161.45.2366.891.41.1503	1182	2642,4	2183	119	2483	2249	52	33	30	9	2363	2369	109	109	10	10	2592	18	144	+9,0	-1,8	109	123,2	246,4	180,0	360,0	30							
161.45.2510.890.11.1503 161.45.2510.891.41.1503	1258	2786,4	2327	119	2627	2393	56	33	30	10	2507	2513	109	109	10	10	2736	18	152	+9,0	-1,8	109	123,2	246,4	180,0	360,0	31							
161.45.2654.890.11.1503 161.45.2654.891.41.1503	1329	2930,4	2471	119	2771	2537	60	33	30	10	2651	2657	109	109	10	10	2880	18	160	+9,0	-1,8	109	123,2	246,4	180,0	360,0	32							

Bearings with internal gear

162.45.2240.890.11.1503 162.45.2240.891.41.1503	1100	2423	1962	119	2357	2123	48	33	30	8	2243	2237	109	109	10	10	1980	18	110	-9,0	-	109	123,2	246,4	180,0	360,0	29
162.45.2366.890.11.1503 162.45.2366.891.41.1503	1160	2549	2088	119	2483	2249	52	33	30	9	2369	2363	109	109	10	10	2106	18	117	-9,0	-	109	123,2	246,4	180,0	360,0	30
162.45.2510.890.11.1503 162.45.2510.891.41.1503	1231	2693	2232	119	2627	2393	56	33	30	10	2513	2507	109	109	10	10	2250	18	125	-9,0	-	109	123,2	246,4	180,0	360,0	31
162.45.2654.890.11.1503 162.45.2654.891.41.1503	1302	2837	2376	119	2771	2537	60	33	30	10	2657	2651	109	109	10	10	2394	18	133	-9,0	-	109	123,2	246,4	180,0	360,0	32

Gear normalized

Gear quenched and tempered

Static limiting load curves

—— Raceway - - - Bolts

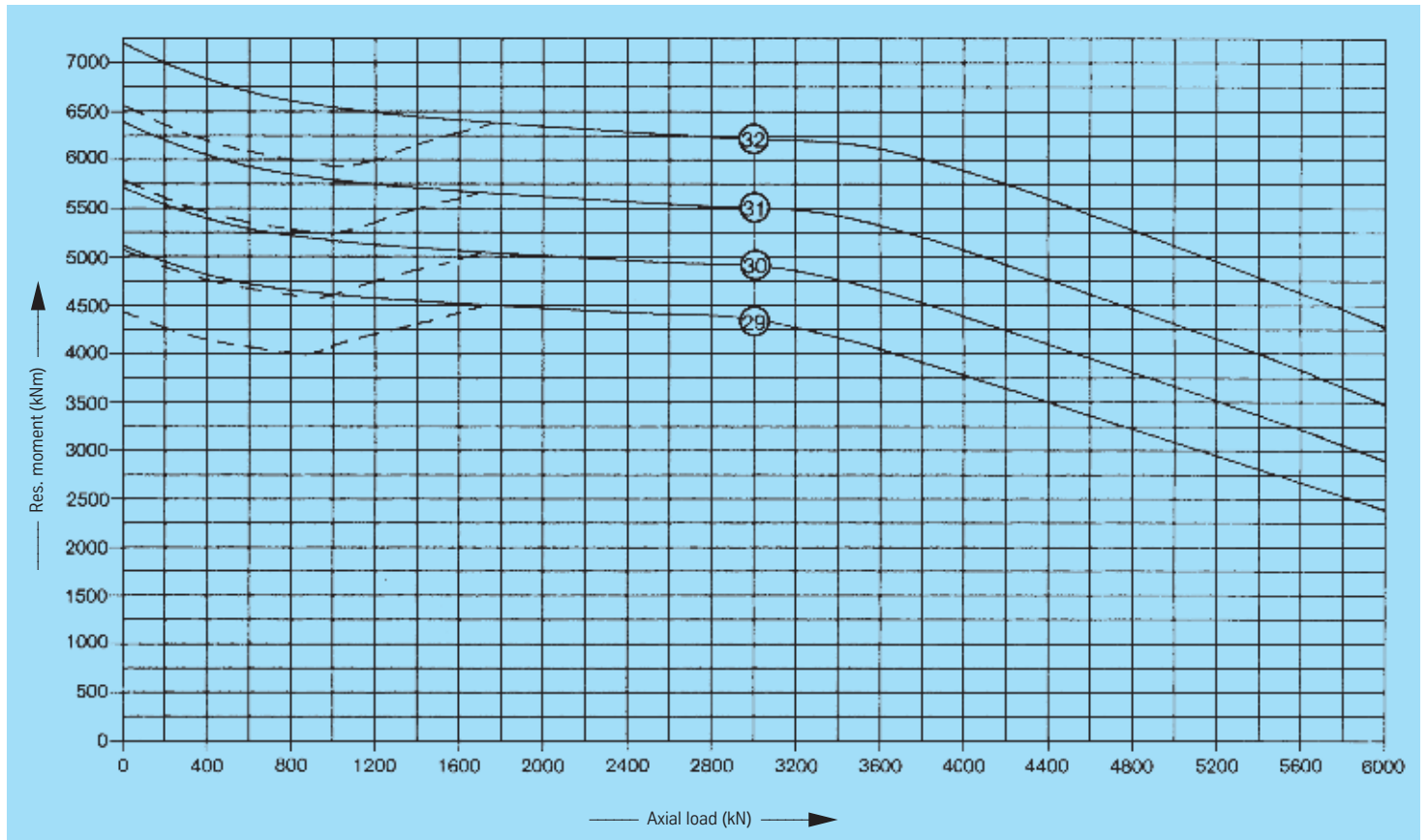

Standard series RD 800



Rothe Erde
Slewing Bearings

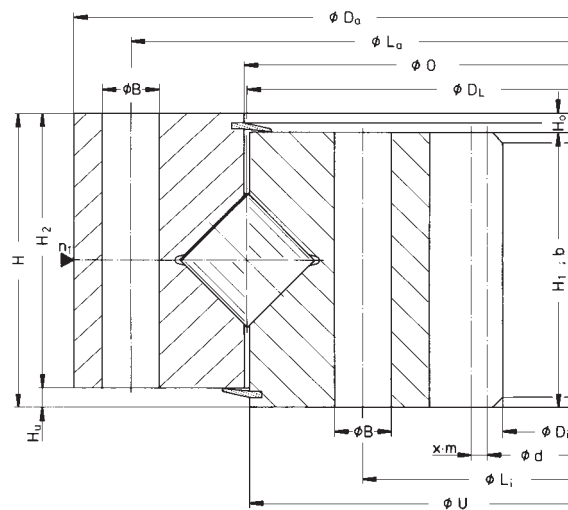
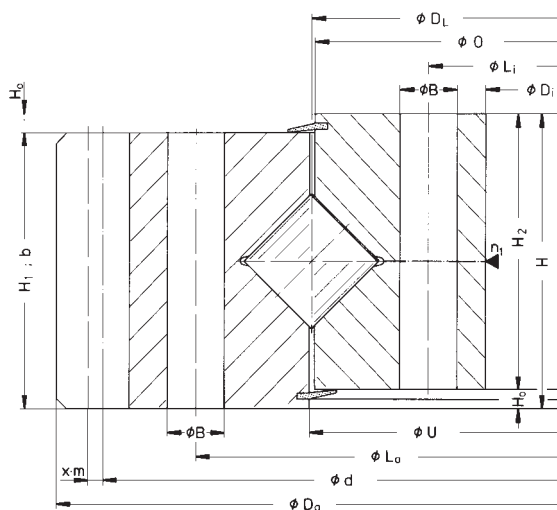

Service life curves · 30,000 revolutions

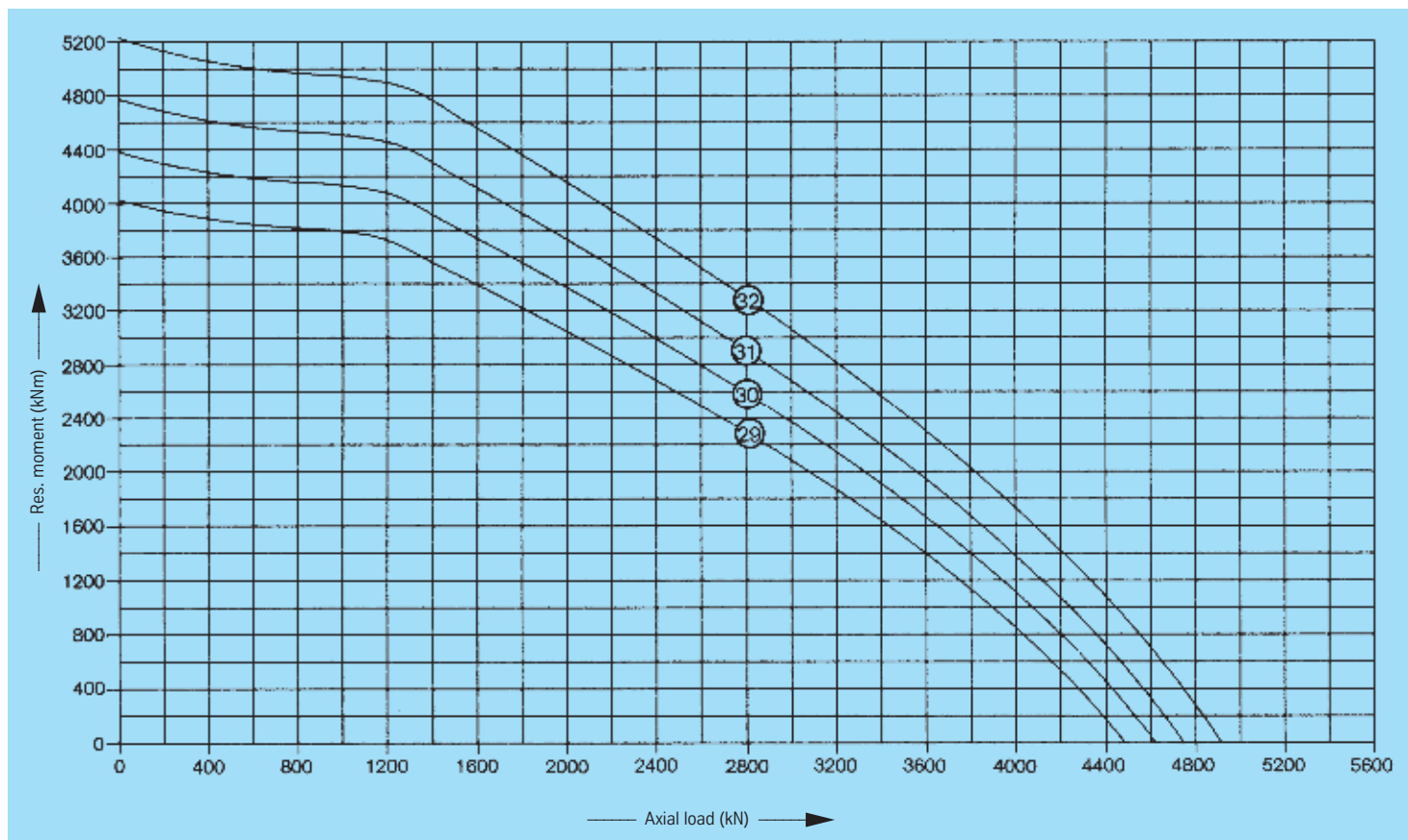

Standard series RD 800



Rothe Erde
Slewing Bearings

Bearings with external gear

Drawing No. Roller track dia. D_t [mm]	Weight [kg]	Outer diameter (O.D.) D_o [mm]	Inner diameter (I.D.) D_i [mm]	Overall height H [mm]	External bolt circle dia. L_e [mm]	Internal bolt circle dia. L_i [mm]	Number of bolt holes per hole circle n	Bolt hole diameter B [mm]	Bolt size M [mm]	Number of grease nipples n_1	Diameter O [mm]	Diameter U [mm]	Ring height H_1 [mm]	Ring height H_2 [mm]	Distance at bottom Outer ring/inner ring H_b [mm]	Distance at top Outer ring/inner ring H_o [mm]	Gear P.C.D. d [mm]	Module m [mm]	Number of teeth z	Addendum modification sign per DIN 3960 October, 1976 $x \cdot m$ [mm]	Addendum reduction $k \cdot m$ [mm]	Tooth width b [mm]	Permissible tangential forces, normal [kN]	Permissible tangential forces, maximum [kN]	Curves
161.50.2500.891.41.1503	1453	2796	2309	130	2625	2375	60	33	30	10	2497	2503	120	120	10	10	2740	20	137	+10,0	-2,0	120	208,6	417,2	33
161.50.2660.891.41.1503	1544	2956	2469	130	2785	2535	64	33	30	12	2657	2663	120	120	10	10	2900	20	145	+10,0	-2,0	120	208,6	417,2	34
161.50.2800.891.41.1503	1616	3096	2609	130	2925	2675	72	33	30	12	2797	2803	120	120	10	10	3040	20	152	+10,0	-2,0	120	208,6	417,2	35
161.50.3000.891.41.1503	1733	3296	2809	130	3125	2875	76	33	30	14	2997	3003	120	120	10	10	3240	20	162	+10,0	-2,0	120	208,6	417,2	36

Bearings with internal gear

162.50.2500.891.41.1503	1423	2691	2200	130	2625	2375	60	33	30	10	2503	2497	120	120	10	10	2220	20	111	-10,0	-	120	208,6	417,2	33
162.50.2660.891.41.1503	1515	2851	2360	130	2785	2535	64	33	30	12	2663	2657	120	120	10	10	2380	20	119	-10,0	-	120	208,6	417,2	34
162.50.2800.891.41.1503	1588	2991	2500	130	2925	2675	72	33	30	12	2803	2797	120	120	10	10	2520	20	126	-10,0	-	120	208,6	417,2	35
162.50.3000.891.41.1503	1706	3191	2700	130	3125	2875	76	33	30	14	3003	2997	120	120	10	10	2720	20	136	-10,0	-	120	208,6	417,2	36

Gear quenched and tempered

Static limiting load curves

—— Raceway - - - Bolts

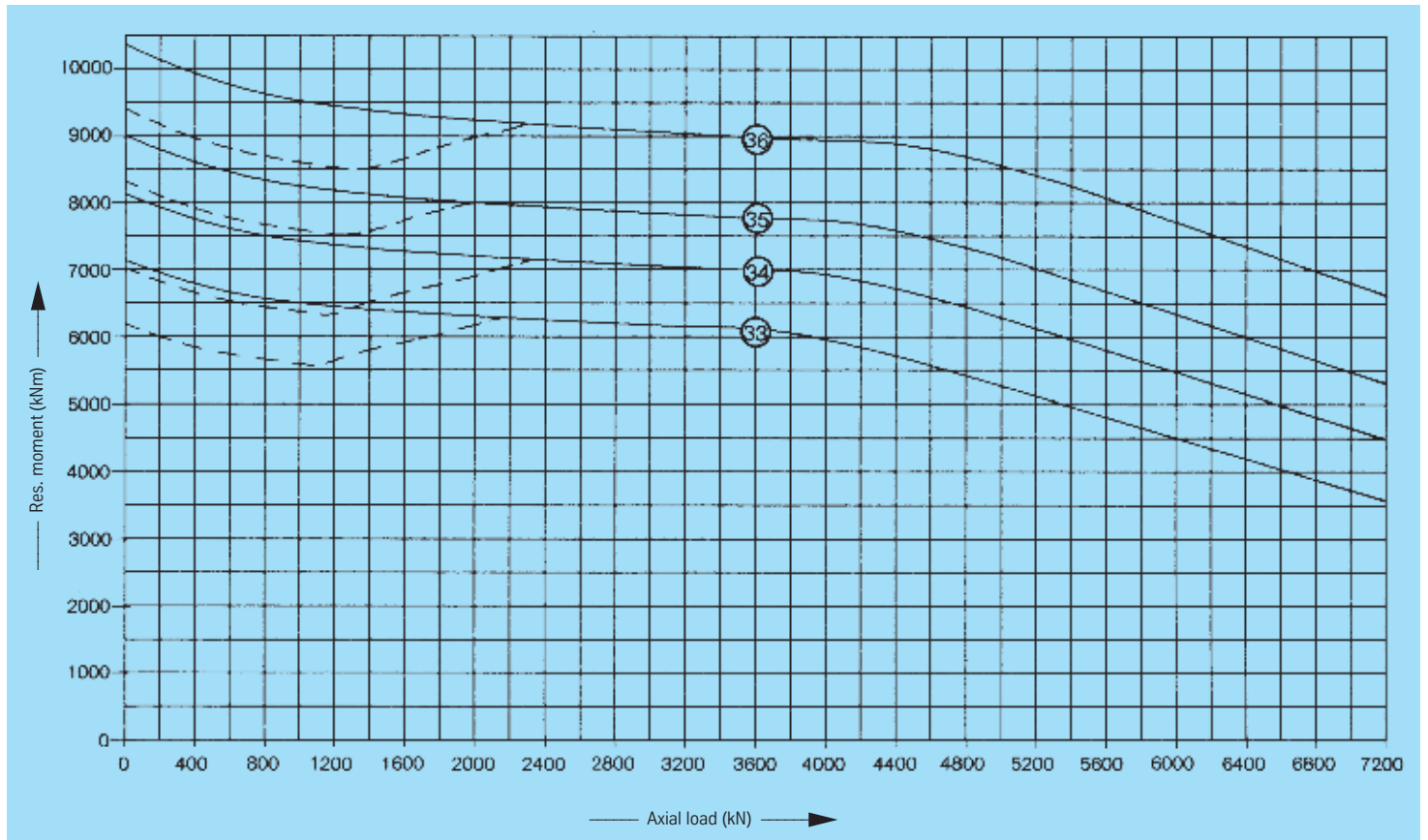

Standard series RD 800



Rothe Erde
Slewing Bearings

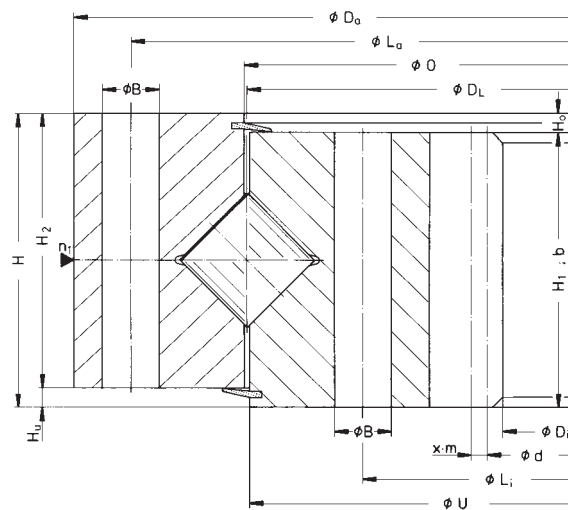
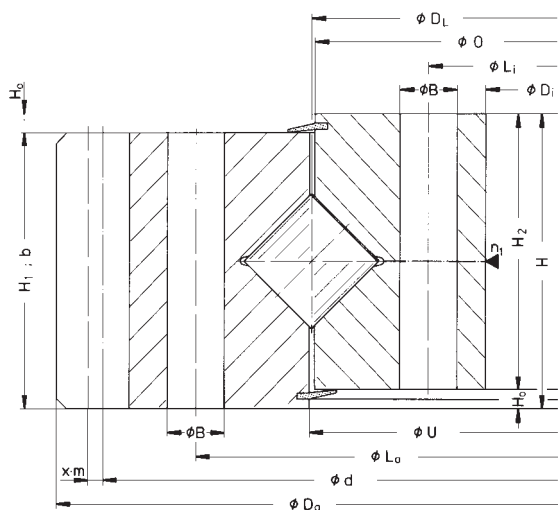

Service life curves · 30,000 revolutions

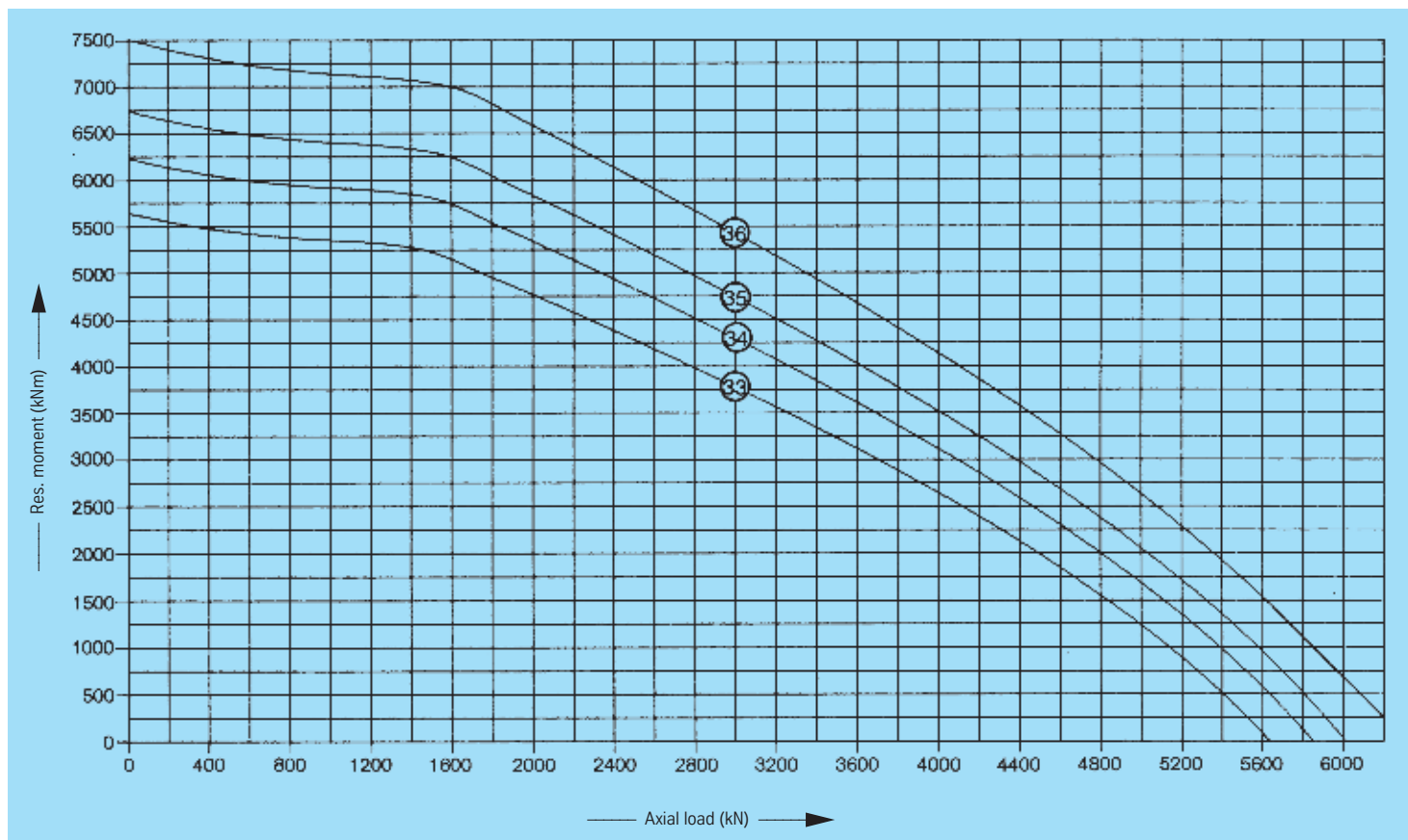



Rothe Erde
Slewing Bearings

Standard series RD 900

Three-row roller bearing slewing rings

Axial roller bearings

Pages 155 – 167



Standard series RD 900



Rothe Erde
Slewing Bearings

Bearings with external gear

Drawing No. Roller track dia. D_t [mm]	Weight [kg]	Outer diameter (O.D.) D_o [mm]	Inner diameter (I.D.) D_i [mm]	Overall height H [mm]	External bolt circle dia. L_e [mm]	Internal bolt circle dia. L_i [mm]	Number of bolt holes per hole circle n	Bolt hole diameter B [mm]	Bolt size M [mm]	Number of grease nipples per level n_1	Diameter O [mm]	Diameter U [mm]	Ring height H_1 [mm]	Ring height H_2 [mm]	Distance at bottom Outer ring/inner ring H_b [mm]	Distance at top Outer ring/inner ring H_o [mm]	Gear P.C.D. d [mm]	Module m [mm]	Number of teeth z	Addendum modification sign per DIN 3960 October, 1976 $x \cdot m$ [mm]	Addendum reduction $k \cdot m$ [mm]	Tooth width b [mm]	Permissible tangential forces, normal [kN]	Permissible tangential forces, maximum [kN]	Curves
191.20.1250.990.41.1502	542	1461,6	1103	132	1355	1155	36	26	24	3	1280	1282	106	123	9	26	1428	12	119	+6	-1,2	106	116,7	233,4	①
191.20.1400.990.41.1502	646	1635,2	1253	132	1505	1305	36	26	24	3	1430	1432	106	123	9	26	1596	14	114	+7	-1,4	106	136,2	272,4	②
191.20.1600.990.41.1502	731	1831,2	1453	132	1705	1505	40	26	24	4	1630	1632	106	123	9	26	1792	14	128	+7	-1,4	106	136,2	272,4	③
191.20.1800.990.41.1502	844	2044,8	1653	132	1905	1705	46	26	24	5	1830	1832	106	123	9	26	2000	16	125	+8	-1,6	106	155,6	311,2	④
191.20.2000.990.41.1502	912	2236,8	1853	132	2105	1905	54	26	24	5	2030	2032	106	123	9	26	2192	16	137	+8	-1,6	106	155,6	311,2	⑤

Bearings with internal gear

192.20.1250.990.41.1502	539	1397	1032	132	1345	1145	36	26	24	3	1219	1218	106	123	9	26	1044	12	87	-6	-	106	116,7	233,4	①
192.20.1400.990.41.1502	630	1547	1162	132	1495	1295	36	26	24	3	1369	1368	106	123	9	26	1176	14	84	-7	-	106	136,2	272,4	②
192.20.1600.990.41.1502	705	1747	1372	132	1695	1495	40	26	24	4	1569	1568	106	123	9	26	1386	14	99	-7	-	106	136,2	272,4	③
192.20.1800.990.41.1502	829	1947	1552	132	1895	1695	46	26	24	5	1769	1768	106	123	9	26	1568	16	98	-8	-	106	155,6	311,2	④
192.20.2000.990.41.1502	902	2147	1760	132	2095	1895	54	26	24	5	1969	1968	106	123	9	26	1776	16	111	-8	-	106	155,6	311,2	⑤

Bearing rings quenched and tempered

Static limiting load curves

—— Raceway - - - Bolts

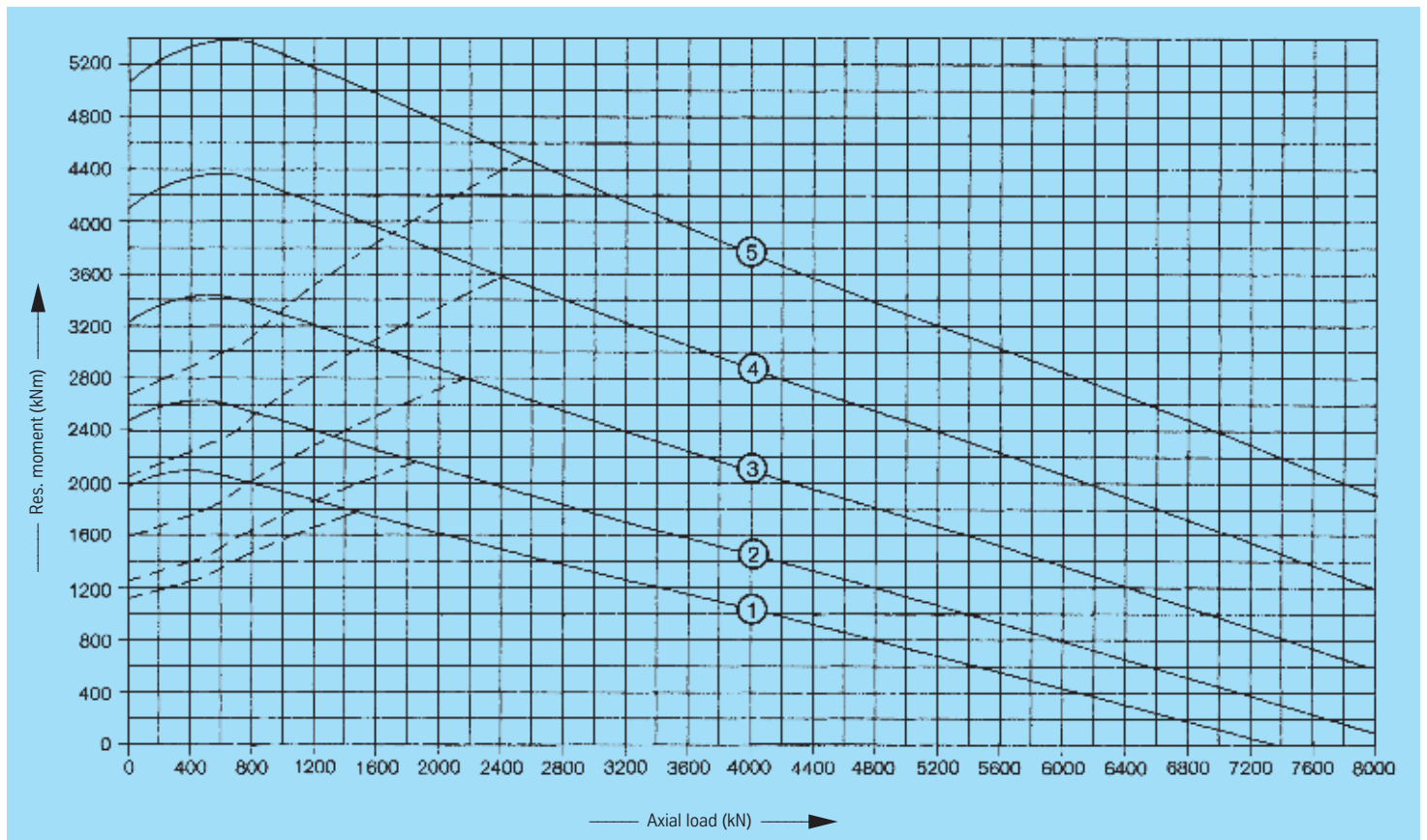

Standard series RD 900



Rothe Erde
Slewing Bearings

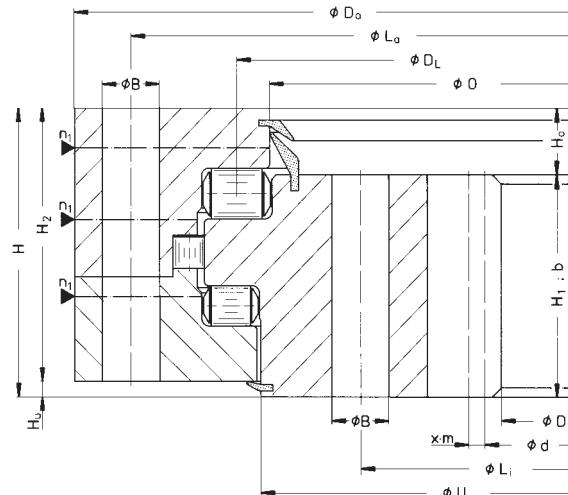
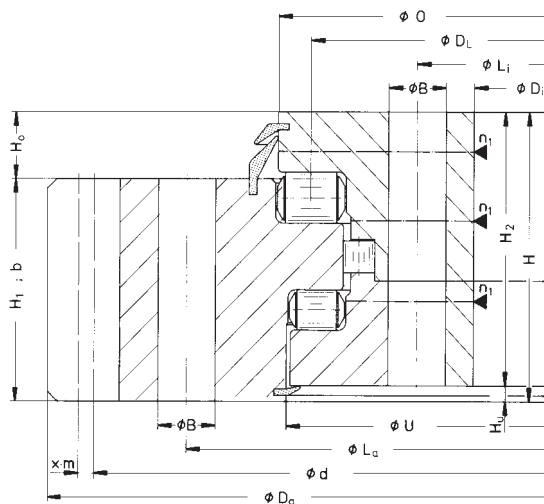

Service life curves · 30,000 revolutions

drawing position = mounting position

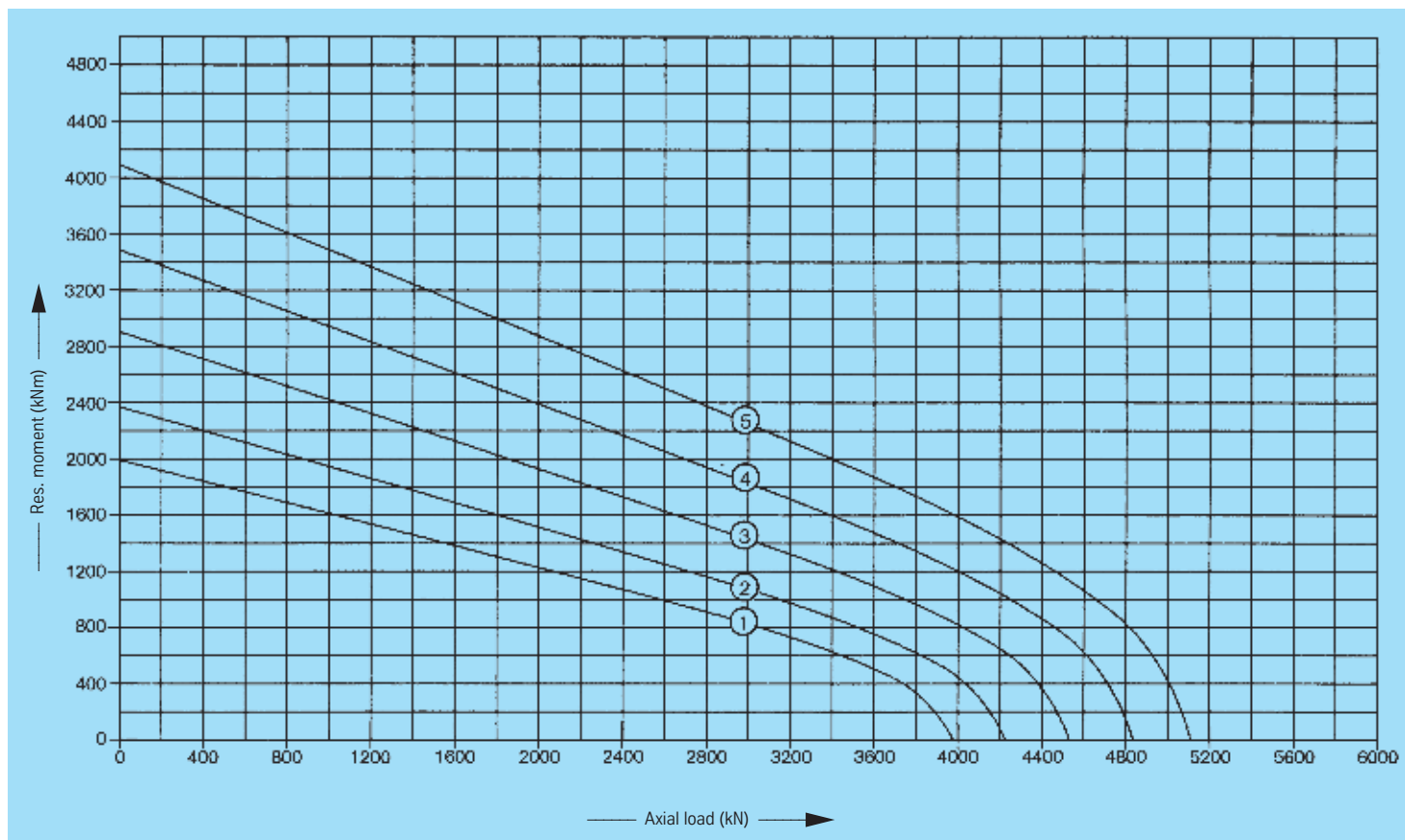

Standard series RD 900



Rothe Erde
Slew Bearings

Bearings with external gear

Drawing No. Roller track dia. D_t [mm]	Weight [kg]	Outer diameter (O.D.) D_o [mm]	Inner diameter (I.D.) D_i [mm]	Overall height H [mm]	External bolt circle dia. L_e [mm]	Internal bolt circle dia. L_i [mm]	Number of bolt holes per hole circle n	Bolt hole diameter B [mm]	Bolt size M [mm]	Number of grease nipples per level n_1	Diameter O [mm]	Diameter U [mm]	Ring height H_1 [mm]	Ring height H_2 [mm]	Distance at bottom Outer ring/inner ring H_b [mm]	Distance at top Outer ring/inner ring H_o [mm]	Gear P.C.D. d [mm]	Module m [mm]	Number of teeth z	Addendum modification sign per DIN 3960 October, 1976 $x \cdot m$ [mm]	Addendum reduction $k \cdot m$ [mm]	Tooth width b [mm]	Permissible tangential forces, normal [kN]	Permissible tangential forces, maximum [kN]	Curves
191.25.1800.990.41.1502	1126	2076,8	1619	147	1925	1685	36	33	30	6	1836	1826	117	138	9	30	2032	16	127	+ 8	-1,6	117	162,7	325,4	⑥
191.25.2000.990.41.1502	1216	2268,8	1819	147	2125	1885	44	33	30	7	2036	2026	117	138	9	30	2224	16	139	+ 8	-1,6	117	162,7	325,4	⑦
191.25.2240.990.41.1502	1378	2516,4	2059	147	2366	2125	48	33	30	8	2276	2266	117	138	9	30	2466	18	137	+ 9	-1,8	117	183,1	366,2	⑧
191.25.2500.990.41.1502	1567	2786,4	2319	147	2625	2385	54	33	30	6	2536	2526	117	138	9	30	2736	18	152	+ 9	-1,8	117	183,1	366,2	⑨
191.25.2800.990.41.1502	1785	3096	2619	147	2925	2685	60	33	30	10	2836	2826	117	138	9	30	3040	20	152	+10	-2,0	117	203,4	406,8	⑩

Bearings with internal gear

192.25.1800.990.41.1502	1101	1981	1520	147	1915	1675	36	33	30	6	1763	1774	117	138	9	30	1536	16	96	- 8	-	117	162,7	325,4	⑥
192.25.2000.990.41.1502	1202	2181	1728	147	2115	1875	44	33	30	7	1963	1974	117	138	9	30	1744	16	109	- 8	-	117	162,7	325,4	⑦
192.25.2240.990.41.1502	1406	2421	1944	147	2355	2115	48	33	30	8	2203	2214	117	138	9	30	1962	18	109	- 9	-	117	183,1	366,2	⑧
192.25.2500.990.41.1502	1545	2681	2214	147	2615	2375	54	33	30	6	2463	2474	117	138	9	30	2232	18	124	- 9	-	117	183,1	366,2	⑨
192.25.2800.990.41.1502	1767	2981	2500	147	2915	2675	60	33	30	10	2763	2774	117	138	9	30	2520	20	126	-10	-	117	203,4	406,8	⑩

Bearing rings quenched and tempered

Static limiting load curves

—— Raceway - - - Bolts

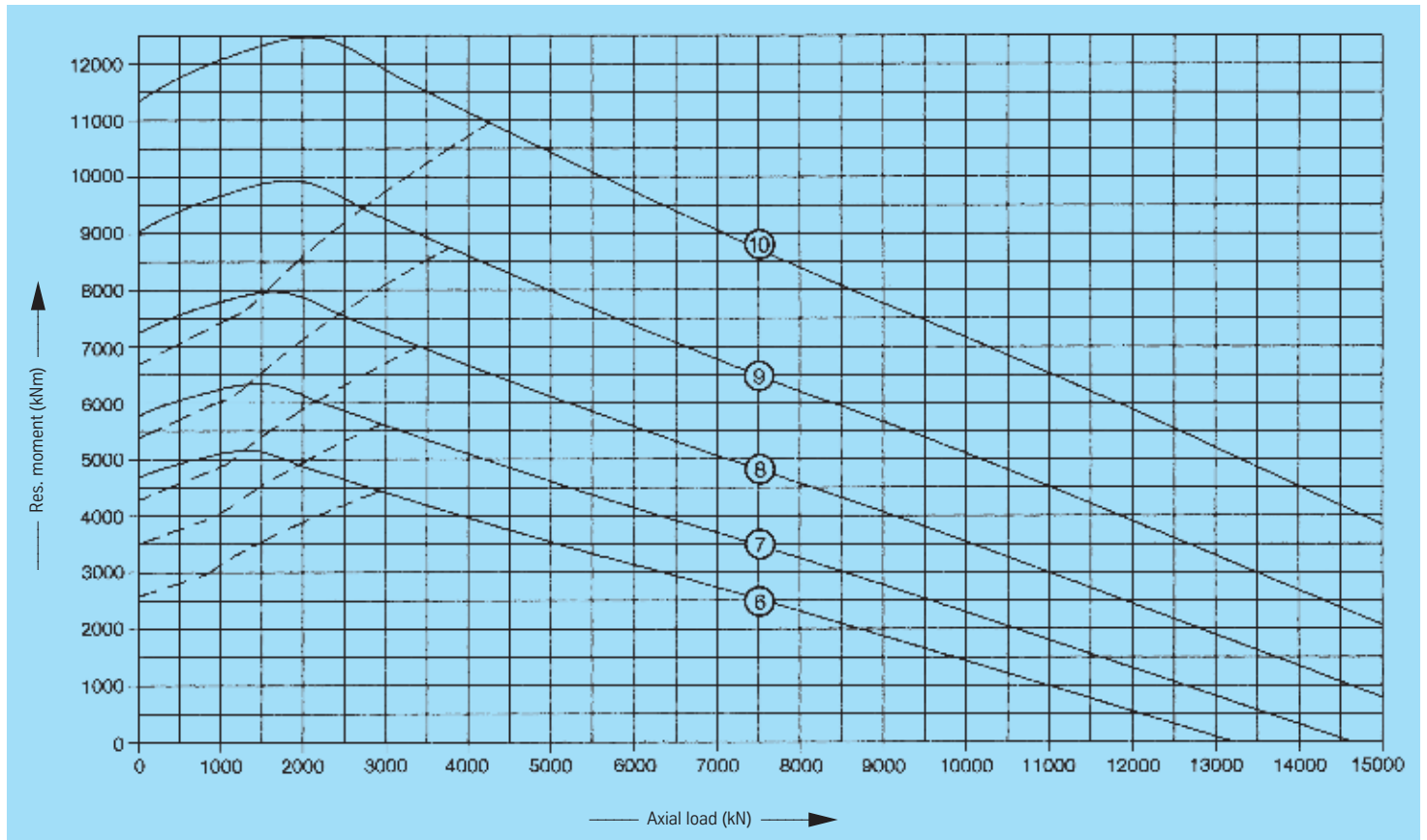

Standard series RD 900



Rothe Erde
Slewing Bearings

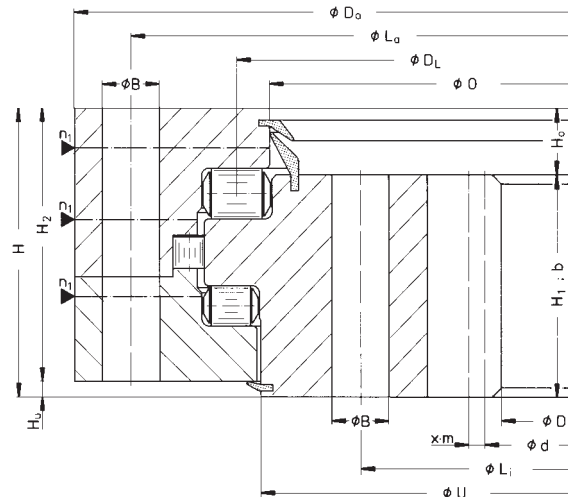
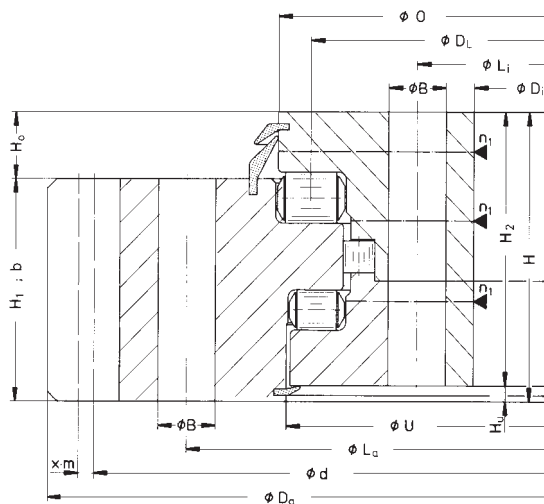

Service life curves · 30,000 revolutions

drawing position = mounting position

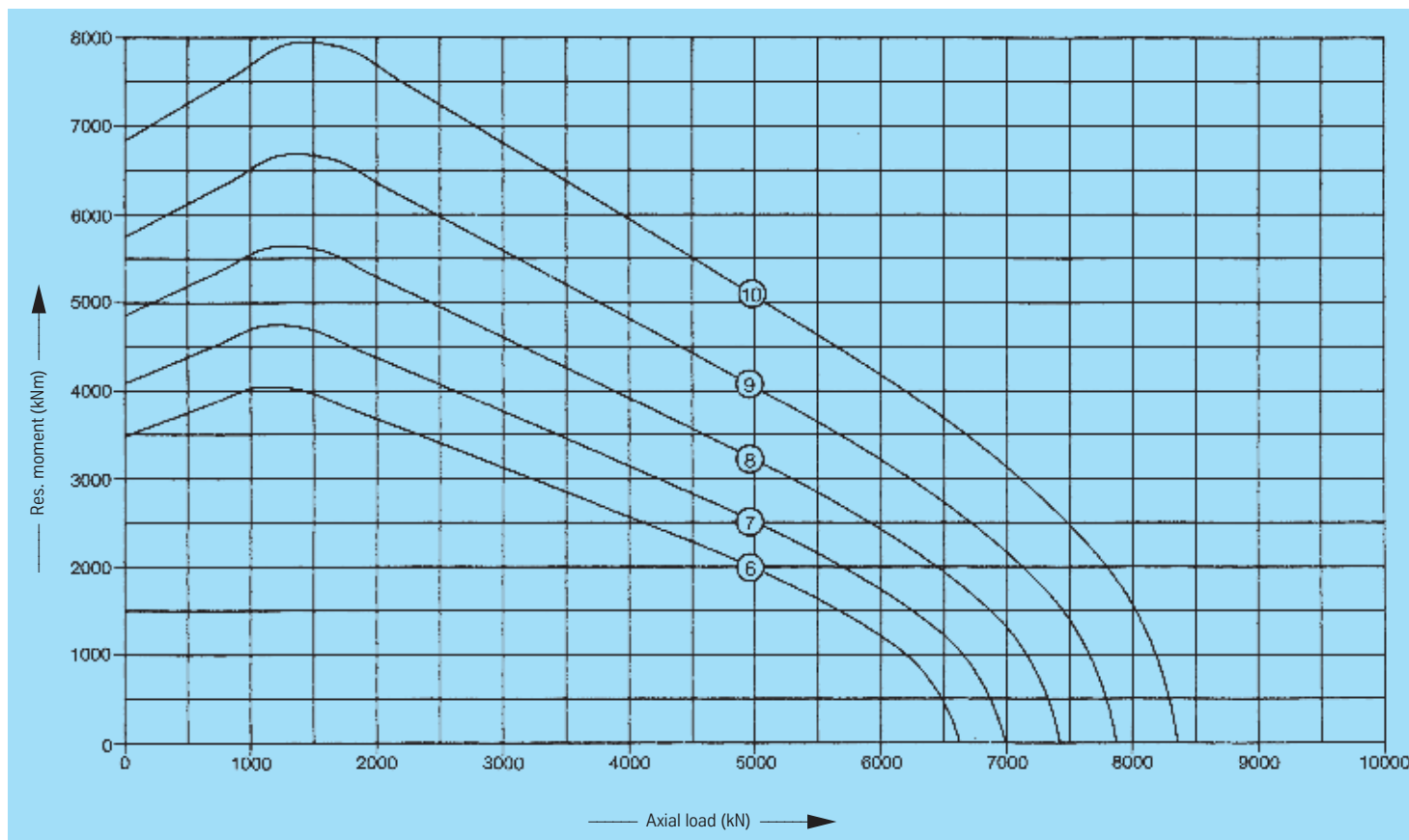

Standard series RD 900



Rothe Erde
Slew Bearings

Bearings with external gear

Drawing No. Roller track dia. D_t [mm]	Weight [kg]	Outer diameter (O.D.) D_o [mm]	Inner diameter (I.D.) D_i [mm]	Overall height H [mm]	External bolt circle dia. L_e [mm]	Internal bolt circle dia. L_i [mm]	Number of bolt holes per hole circle n	Bolt hole diameter B [mm]	Bolt size M [mm]	Number of grease nipples per level n_1	Diameter O [mm]	Diameter U [mm]	Ring height H_1 [mm]	Ring height H_2 [mm]	Distance at bottom Outer ring/inner ring H_b [mm]	Distance at top Outer ring/inner ring H_o [mm]	Gear P.C.D. d [mm]	Module m [mm]	Number of teeth z	Addendum modification sign per DIN 3960 October, 1976 $x \cdot m$ [mm]	Addendum reduction $k \cdot m$ [mm]	Tooth width b [mm]	Permissible tangential forces, normal [kN]	Permissible tangential forces, maximum [kN]	Curves
191.32.2240.990.41.1502	1975	2552,4	2022	181	2395	2100	40	39	36	8	2281	2270	139	172	9	42	2502	18	139	+ 9	-1,8	139	217,6	435,2	11
191.32.2500.990.41.1502	2260	2822,4	2282	181	2655	2360	44	39	36	7	2541	2530	139	172	9	42	2772	18	154	+ 9	-1,8	139	217,6	435,2	12
191.32.2800.990.41.1502	2576	3136	2582	181	2955	2660	48	39	36	8	2841	2830	139	172	9	42	3080	20	154	+10	-2,0	139	241,7	483,4	13
191.32.3150.990.41.1502	2828	3476	2932	181	3305	3010	56	39	36	7	3191	3180	139	172	9	42	3420	20	171	+10	-2,0	139	241,7	483,4	14
191.32.3550.990.41.1502	3249	3889,6	3332	181	3705	3410	66	39	36	8	3591	3580	139	172	9	42	3828	22	174	+11	-2,2	139	265,9	531,8	15
191.32.4000.990.41.1502	3752	4351,6	3782	181	4155	3860	72	39	36	9	4041	4030	139	172	9	42	4290	22	195	+11	-2,2	139	265,9	531,8	16

Bearings with internal gear

192.32.2240.990.41.1502	2010	2458	1908	181	2380	2085	40	39	36	8	2199	2210	139	172	9	42	1926	18	107	- 9	-	139	217,6	435,2	11
192.32.2500.990.41.1502	2210	2718	2178	181	2640	2345	44	39	36	7	2459	2470	139	172	9	42	2196	18	122	- 9	-	139	217,6	435,2	12
192.32.2800.990.41.1502	2542	3018	2460	181	2940	2645	48	39	36	8	2759	2770	139	172	9	42	2480	20	124	-10	-	139	241,7	483,4	13
192.32.3150.990.41.1502	2807	3368	2820	181	3290	2995	56	39	36	7	3109	3120	139	172	9	42	2840	20	142	-10	-	139	241,7	483,4	14
192.32.3550.990.41.1502	3302	3768	3190	181	3690	3395	66	39	36	8	3509	3520	139	172	9	42	3212	22	146	-11	-	139	265,9	531,8	15
192.32.4000.990.41.1502	3664	4218	3652	181	4140	3845	72	39	36	9	3959	3970	139	172	9	42	3674	22	167	-11	-	139	265,9	531,8	16

Static limiting load curves

—— Raceway - - - Bolts

Bearing rings quenched and tempered

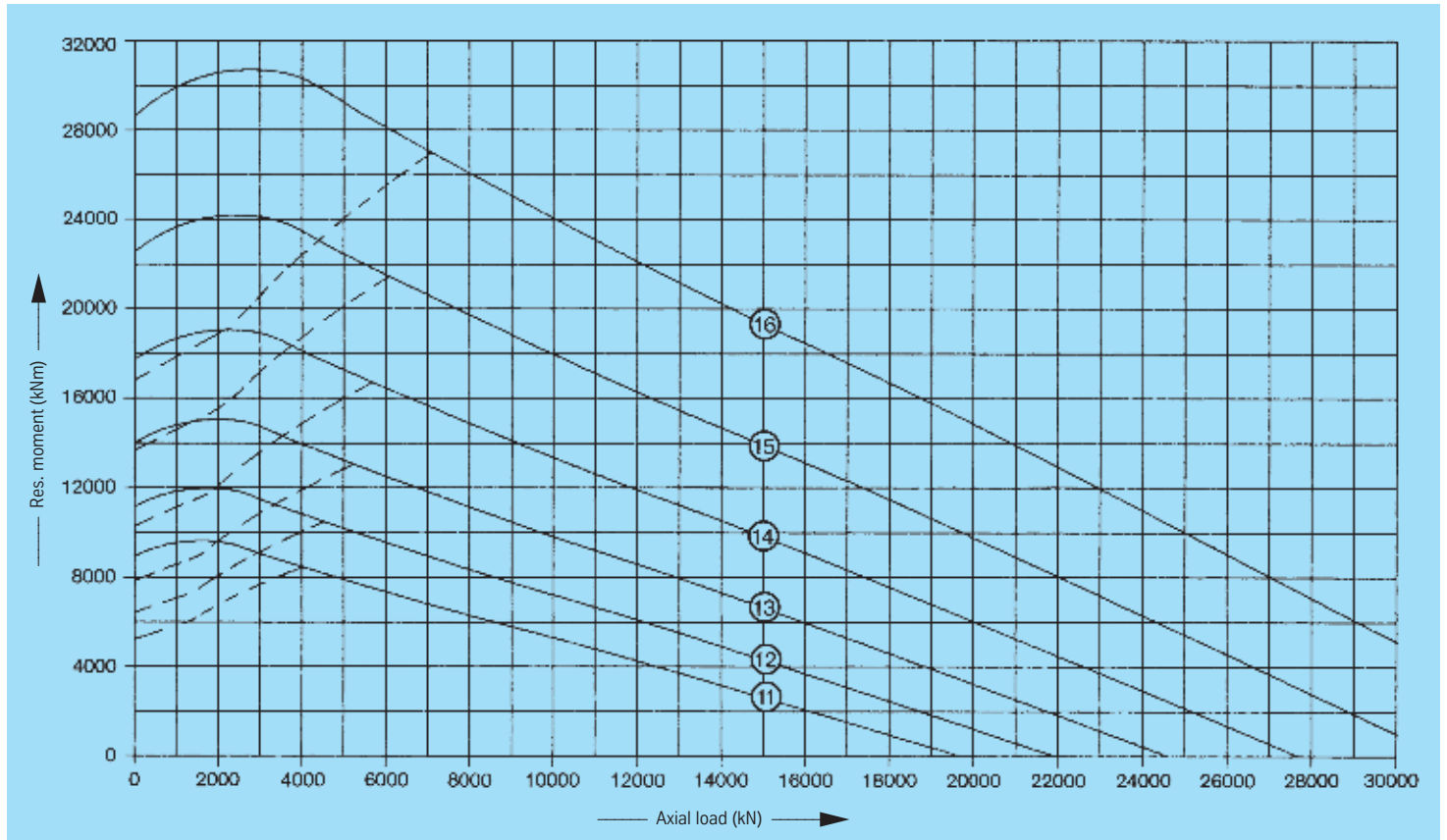

Standard series RD 900



Rothe Erde
Slewing Bearings

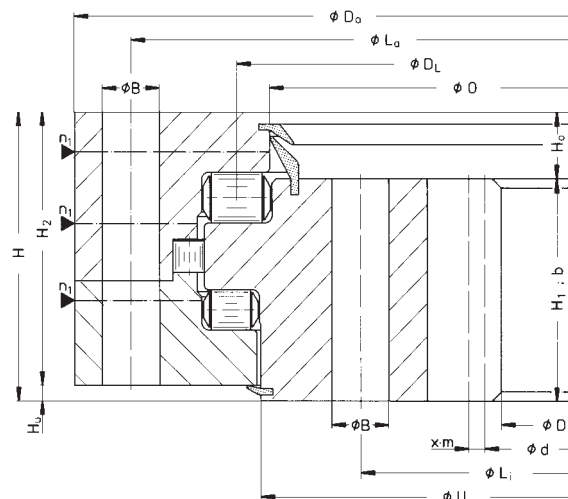
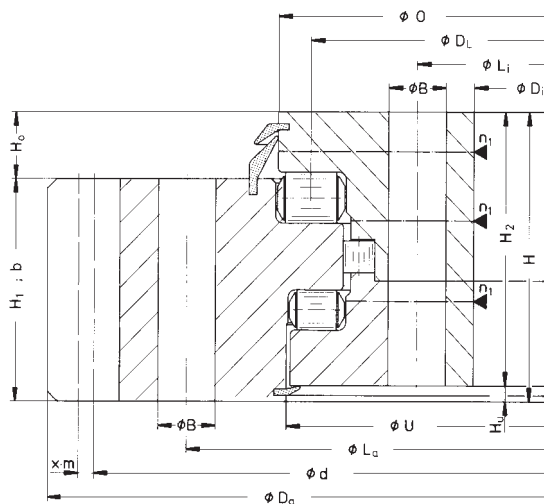

Service life curves · 30,000 revolutions

drawing position = mounting position

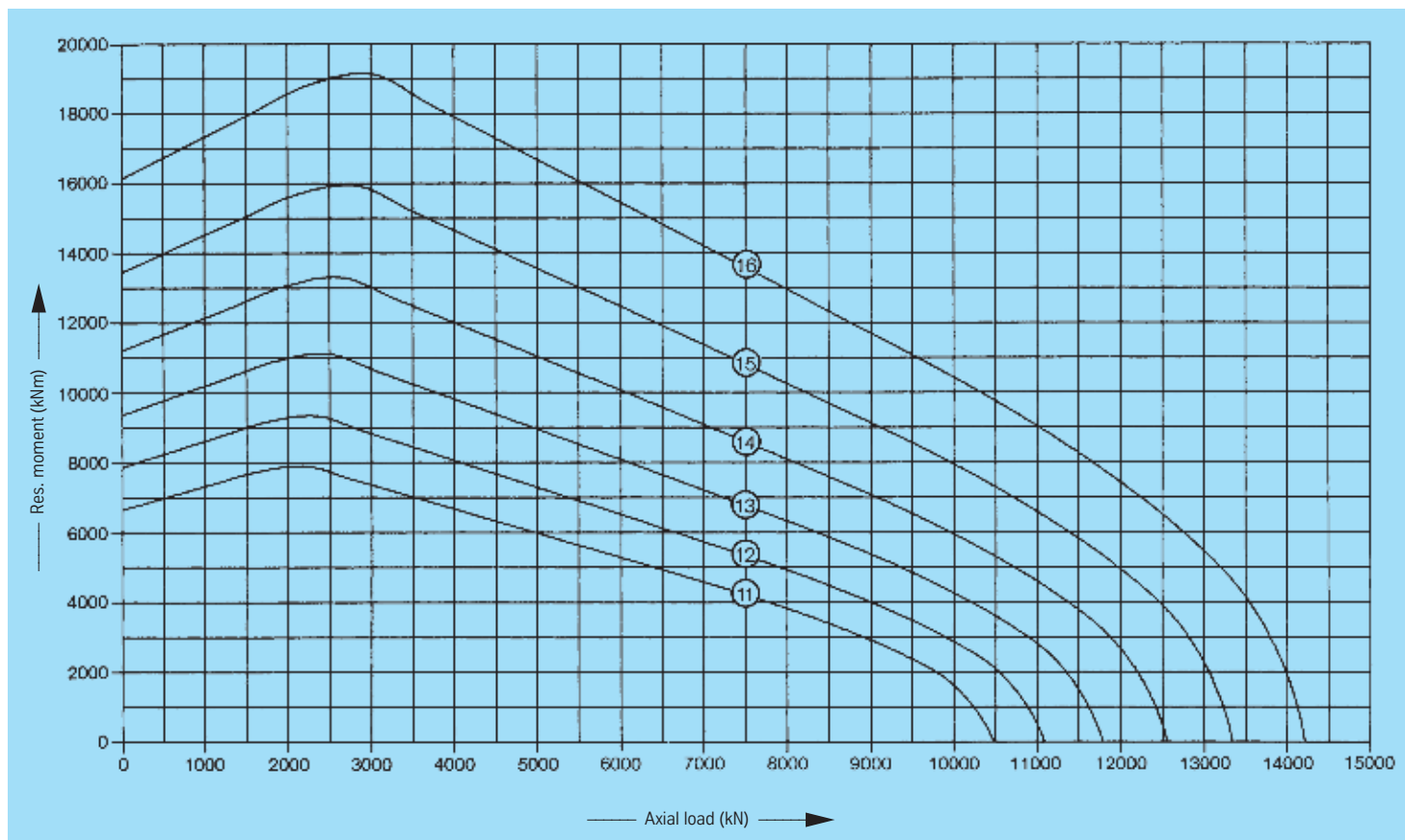

Standard series RD 900



Rothe Erde
Slewing Bearings

Bearings with external gear

Drawing No. Roller track dia. D_t [mm]	Weight [kg]	Outer diameter (O.D.) D_o [mm]	Inner diameter (I.D.) D_i [mm]	Overall height H [mm]	External bolt circle dia. L_e [mm]	Internal bolt circle dia. L_i [mm]	Number of bolt holes per hole circle n	Bolt hole diameter B [mm]	Bolt size M [mm]	Number of grease nipples per level n_1	Diameter O [mm]	Diameter U [mm]	Ring height H_1 [mm]	Ring height H_2 [mm]	Distance at bottom Outer ring/inner ring H_b [mm]	Distance at top Outer ring/inner ring H_o [mm]	Gear P.C.D. d [mm]	Module m [mm]	Number of teeth z	Addendum modification sign per DIN 3960 October, 1976 $x \cdot m$ [mm]	Addendum reduction $k \cdot m$ [mm]	Tooth width b [mm]	Permissible tangential forces, normal [kN]	Permissible tangential forces, maximum [kN]	Curves
191.40.2800.990.41.1502	3267	3136	2562	220	2965	2640	48	39	36	8	2850	2837	170	210	10	50	3080	20	154	+10	-2,0	170	295,7	591,4	17
191.40.3150.990.41.1502	3812	3515,6	2912	220	3315	2990	56	39	36	7	3200	3187	170	210	10	50	3454	22	157	+11	-2,2	170	325,2	650,4	18
191.40.3550.990.41.1502	4255	3911,6	3312	220	3715	3390	66	39	36	8	3600	3587	170	210	10	50	3850	22	175	+11	-2,2	170	325,2	650,4	19
191.40.4000.990.41.1502	4805	4363,2	3762	220	4165	3840	72	39	36	9	4050	4037	170	210	10	50	4296	24	179	+12	-2,4	170	354,8	709,6	20
191.40.4500.990.41.1502	5410	4867,2	4262	220	4665	4340	84	39	36	14	4550	4537	170	210	10	50	4800	24	200	+12	-2,4	170	354,8	709,6	21

Bearings with internal gear

192.40.2800.990.41.1502	3213	3038	2460	220	2960	2635	48	39	36	8	2750	2763	170	210	10	50	2480	20	124	-10	-	170	295,7	591,4	17
192.40.3150.990.41.1502	3683	3388	2794	220	3310	2985	56	39	36	7	3100	3113	170	210	10	50	2816	22	128	-11	-	170	325,2	650,4	18
192.40.3550.990.41.1502	4171	3788	3190	220	3710	3385	66	39	36	8	3500	3513	170	210	10	50	3212	22	146	-11	-	170	325,2	650,4	19
192.40.4000.990.41.1502	4810	4238	3624	220	4160	3835	72	39	36	9	3950	3963	170	210	10	50	3648	24	152	-12	-	170	354,8	709,6	20
192.40.4500.990.41.1502	5367	4738	4128	220	4660	4335	84	39	36	14	4450	4463	170	210	10	50	4152	24	173	-12	-	170	354,8	709,6	21

Bearing rings quenched and tempered

Static limiting load curves

—— Raceway - - - Bolts

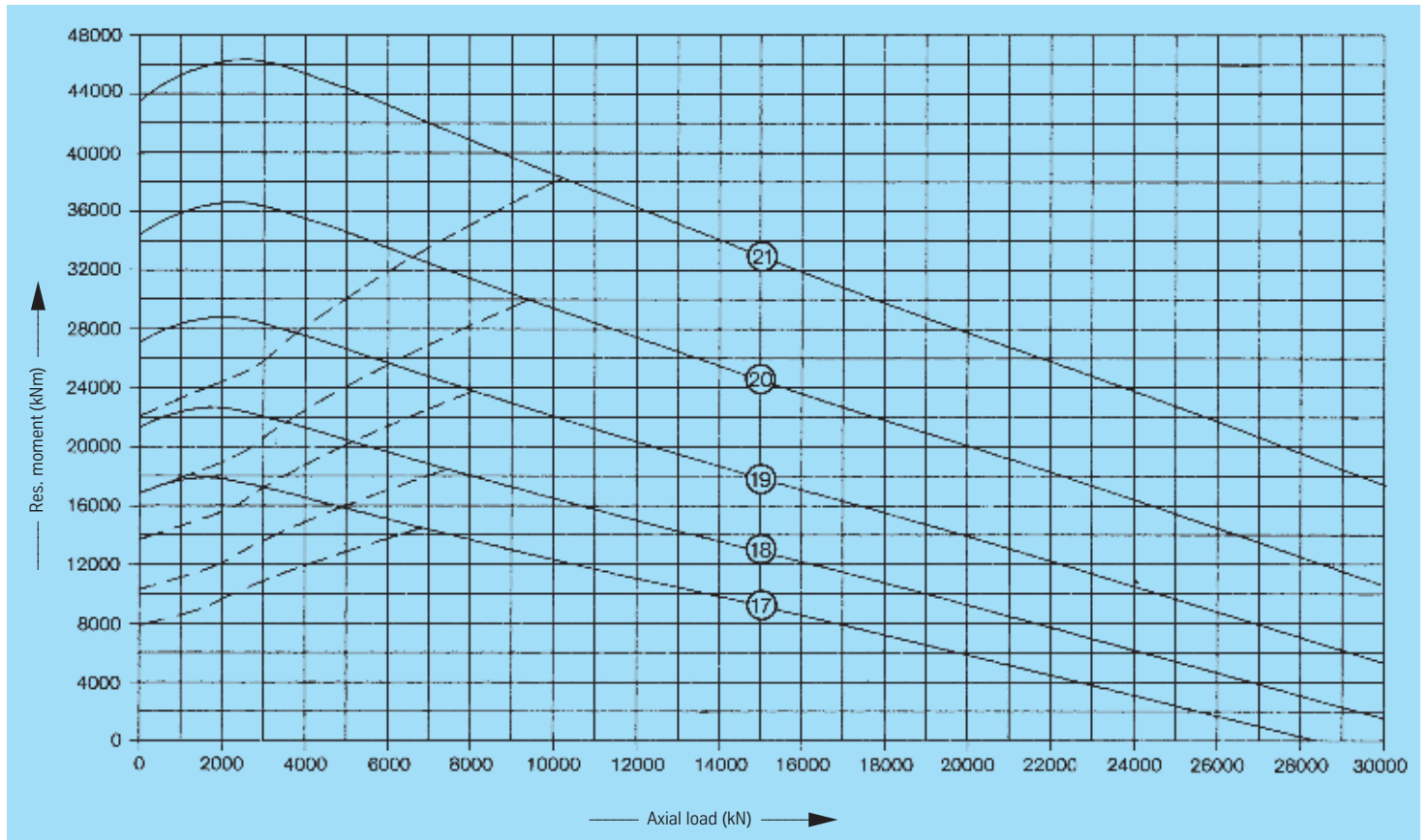

Standard series RD 900



Rothe Erde
Slewing Bearings

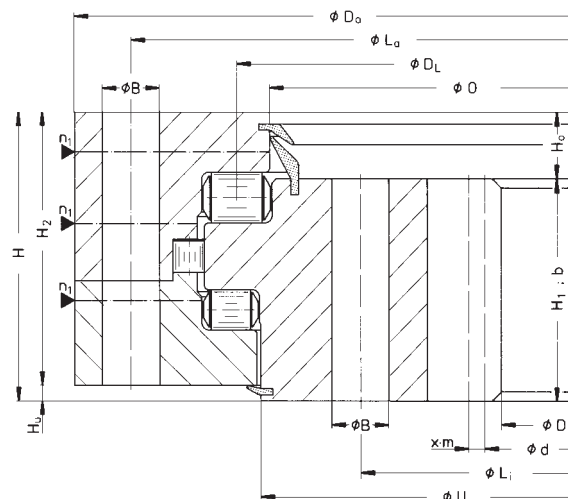
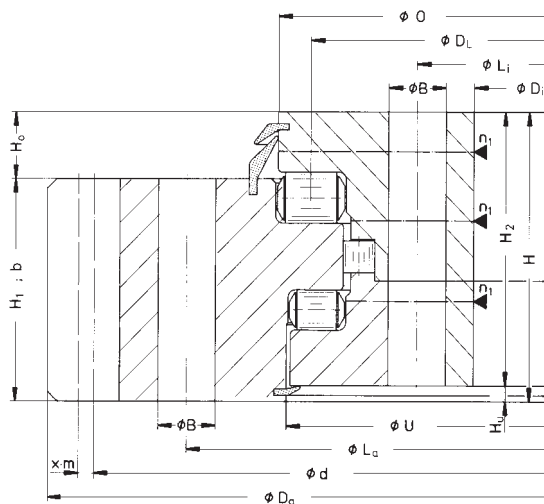

Service life curves · 30,000 revolutions

drawing position = mounting position

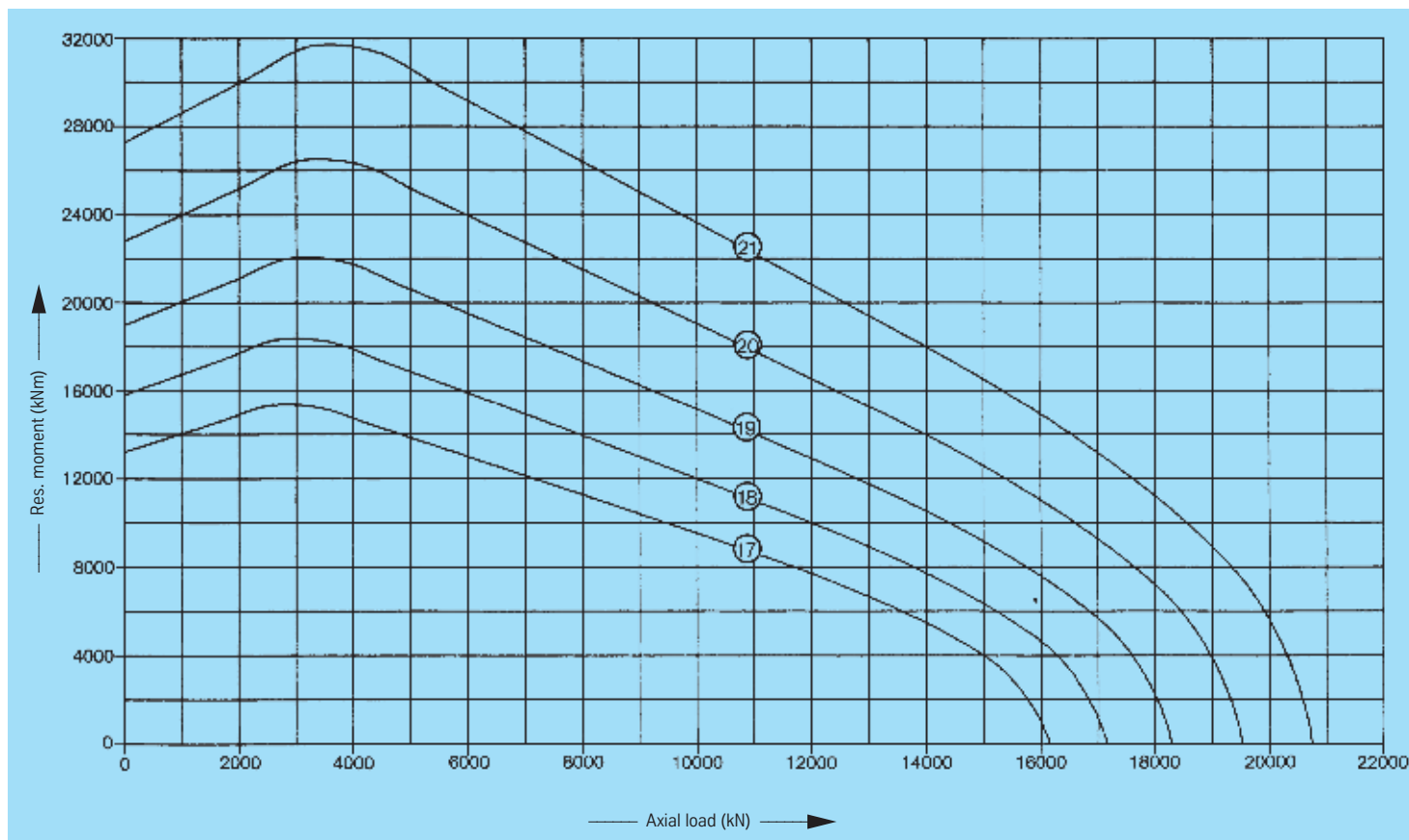

Standard series RD 900



Rothe Erde
Slewing Bearings

Bearings with external gear

Drawing No. Roller track dia. D_L [mm]	Weight [kg]	Outer diameter (O.D.) D_o [mm]	Inner diameter (I.D.) D_i [mm]	Overall height H [mm]	External bolt circle dia. L_e [mm]	Internal bolt circle dia. L_i [mm]	Number of bolt holes per hole circle n	Bolt hole diameter B [mm]	Bolt size M [mm]	Number of grease nipples per level n_1	Diameter O [mm]	Diameter U [mm]	Ring height H_1 [mm]	Ring height H_2 [mm]	Distance at bottom Outer ring/inner ring H_b [mm]	Distance at top Outer ring/inner ring H_o [mm]	Gear P.C.D. d [mm]	Module m [mm]	Number of teeth z	Addendum modification sign per DIN 3960 October, 1976 $x \cdot m$ [mm]	Addendum reduction $k \cdot m$ [mm]	Tooth width b [mm]	Permissible tangential forces, normal [kN]	Permissible tangential forces, maximum [kN]	Curves
191.50.3150.990.41.1502	5298	3571,2	2885	268	3350	2975	48	45	42	8	3210	3196	203	258	10	65	3504	24	146	+12	-2,4	203	423,6	847,2	22
191.50.3550.990.41.1502	5830	3955,2	3285	268	3750	3375	54	45	42	9	3610	3596	203	258	10	65	3888	24	162	+12	-2,4	203	423,6	847,2	23
191.50.4000.990.41.1502	6578	4411,2	3735	268	4200	3825	60	45	42	10	4060	4046	203	258	10	65	4344	24	181	+12	-2,4	203	423,6	847,2	24
191.50.4500.990.41.1502	7456	4915,2	4235	268	4700	4325	68	45	42	11	4560	4546	203	258	10	65	4848	24	202	+12	-2,4	203	423,6	847,2	25

Bearings with internal gear

192.50.3150.990.41.1502	5128	3415	2736	268	3325	2950	48	45	42	8	3090	3104	203	258	10	65	2760	24	115	-12	-	203	423,6	847,2	22
192.50.3550.990.41.1502	5916	3815	3120	268	3725	3350	54	45	42	9	3490	3504	203	258	10	65	3144	24	131	-12	-	203	423,6	847,2	23
192.50.4000.990.41.1502	6623	4265	3576	268	4175	3800	60	45	42	10	3940	3954	203	258	10	65	3600	24	150	-12	-	203	423,6	847,2	24
192.50.4500.990.41.1502	7427	4765	4080	268	4675	4300	68	45	42	11	4440	4454	203	258	10	65	4104	24	171	-12	-	203	423,6	847,2	25

Bearing rings quenched and tempered

Static limiting load curves

—— Raceway - - - Bolts

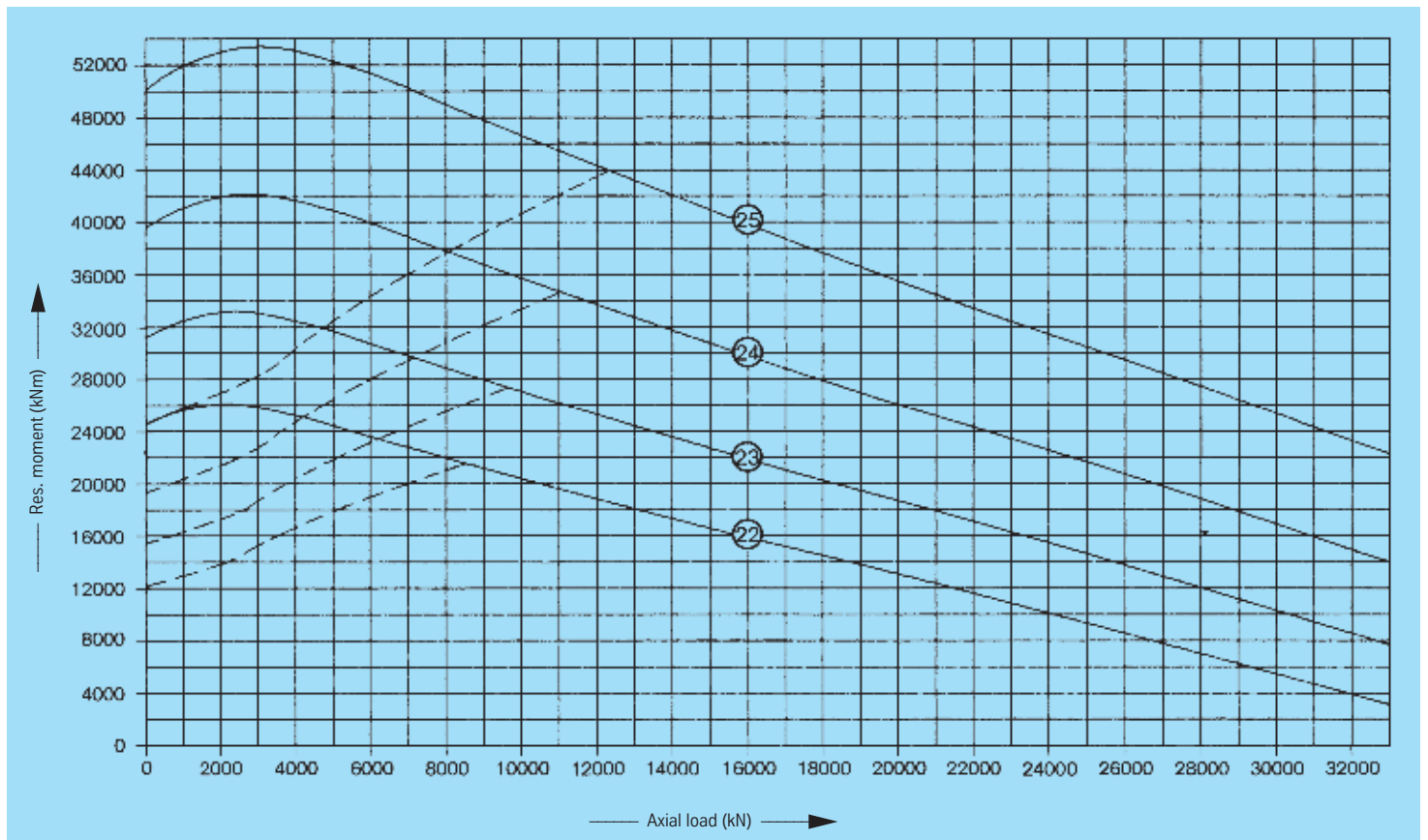

Standard series RD 900



Rothe Erde
Slewing Bearings

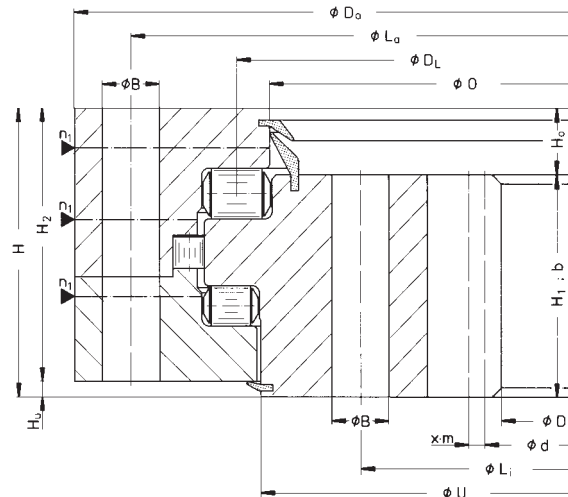
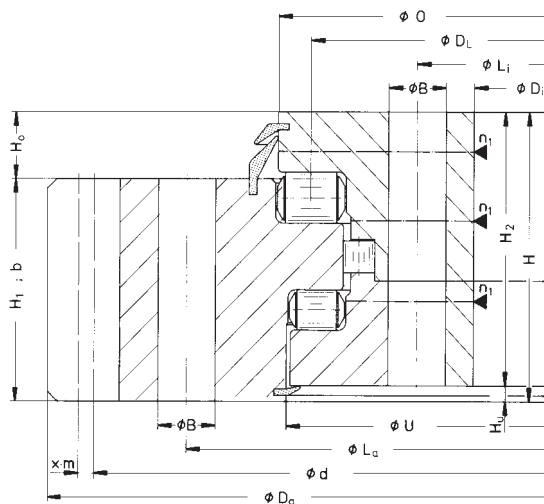

Service life curves · 30,000 revolutions

drawing position = mounting position

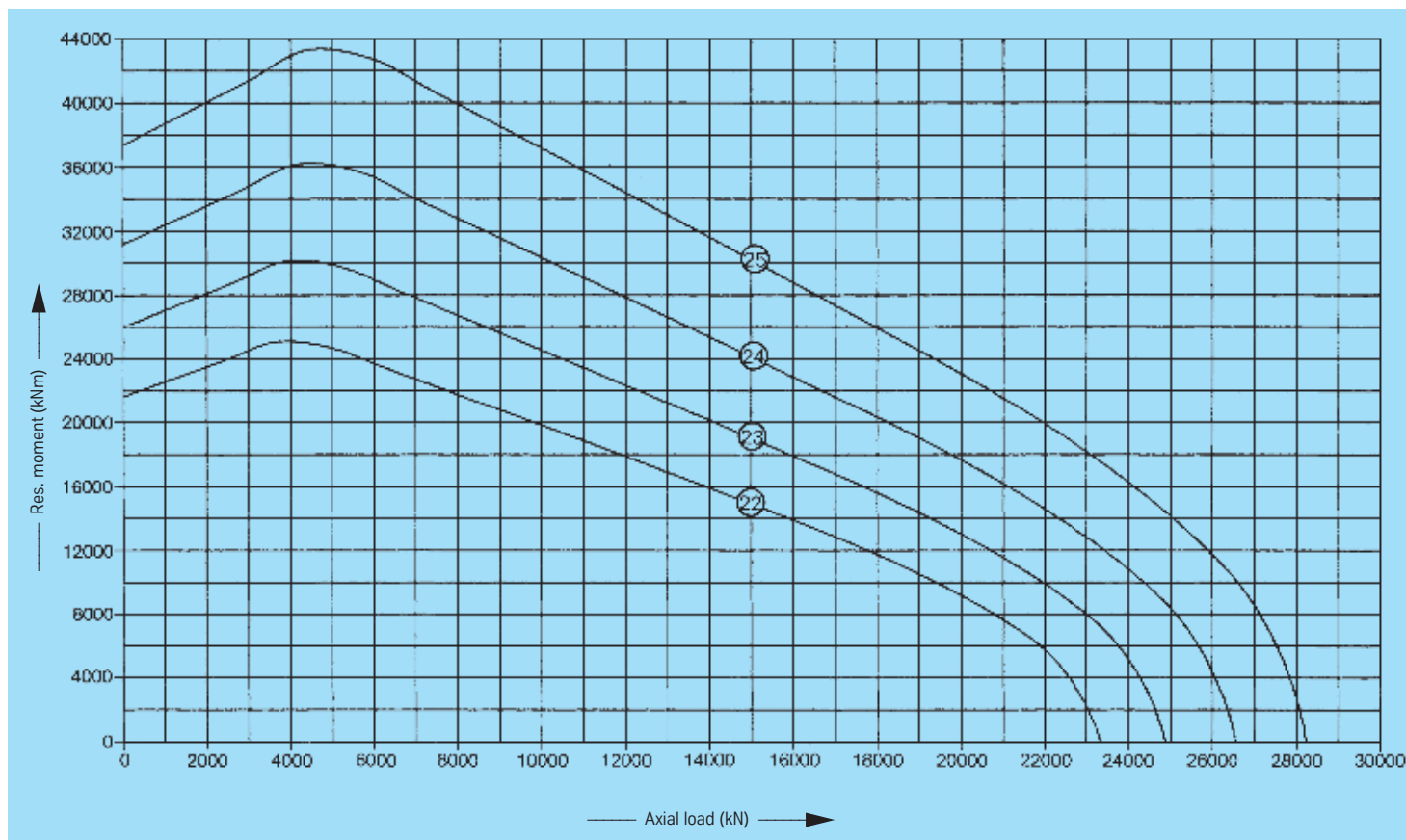

Standard series RD 900



Rothe Erde
Slew Bearings

Bearings with external gear

Drawing No. Roller track dia. D_t [mm]	Weight [kg]	Outer diameter (O.D.) D_o [mm]	Inner diameter (I.D.) D_i [mm]	Overall height H [mm]	External bolt circle dia. L_e [mm]	Internal bolt circle dia. L_i [mm]	Number of bolt holes per hole circle n	Bolt hole diameter B [mm]	Bolt size M [mm]	Number of grease nipples per level n_1	Diameter O [mm]	Diameter U [mm]	Ring height H_1 [mm]	Ring height H_2 [mm]	Distance at bottom Outer ring/inner ring H_b [mm]	Distance at top Outer ring/inner ring H_o [mm]	Gear P.C.D. d [mm]	Module m [mm]	Number of teeth z	Addendum modification sign per DIN 3960 October, 1976 $x \cdot m$ [mm]	Addendum reduction $k \cdot m$ [mm]	Tooth width b [mm]	Permissible tangential forces, normal [kN]	Permissible tangential forces, maximum [kN]	Curves
191.50.5000.990.41.1502	8259	5419,2	4735	268	5200	4825	78	45	42	13	5060	5046	203	258	10	65	5328	24	222	+24	-2,4	203	423,6	847,2	26
191.50.5600.990.41.1502	9448	6019,2	5335	268	5800	5425	90	45	42	15	5660	5646	203	258	10	65	5952	24	248	+12	-2,4	203	423,6	847,2	27
191.50.6300.990.41.1502	10536	6715,2	6035	268	6500	6125	100	45	42	18	6360	6346	203	258	10	65	6624	24	276	+24	-2,4	203	423,6	847,2	28
191.50.6735.990.41.1502	11200	7147,2	6470	268	6935	6560	108	45	42	18	6795	6781	203	258	10	65	7080	24	295	+12	-2,4	203	423,6	847,2	29

Bearings with internal gear

192.50.5000.990.41.1501	8182	5265	4584	268	5175	4800	78	45	42	13	4940	4954	203	258	10	65	4608	24	192	-12	-	203	423,6	847,2	26
192.50.5600.990.41.1502	9317	5865	5184	268	5775	5400	90	45	42	15	5540	5554	203	258	10	65	5208	24	217	-12	-	203	423,6	847,2	27
192.50.6300.990.41.1502	10555	6565	5880	268	6475	6100	100	45	42	18	6240	6254	203	258	10	65	5904	24	246	-12	-	203	423,6	847,2	28
192.50.6735.990.41.1502	11330	7000	6312	268	6910	6535	108	45	42	18	6675	6689	203	258	10	65	6336	24	264	-12	-	203	423,6	847,2	29

Bearing rings quenched and tempered

Static limiting load curves

—— Raceway - - - Bolts

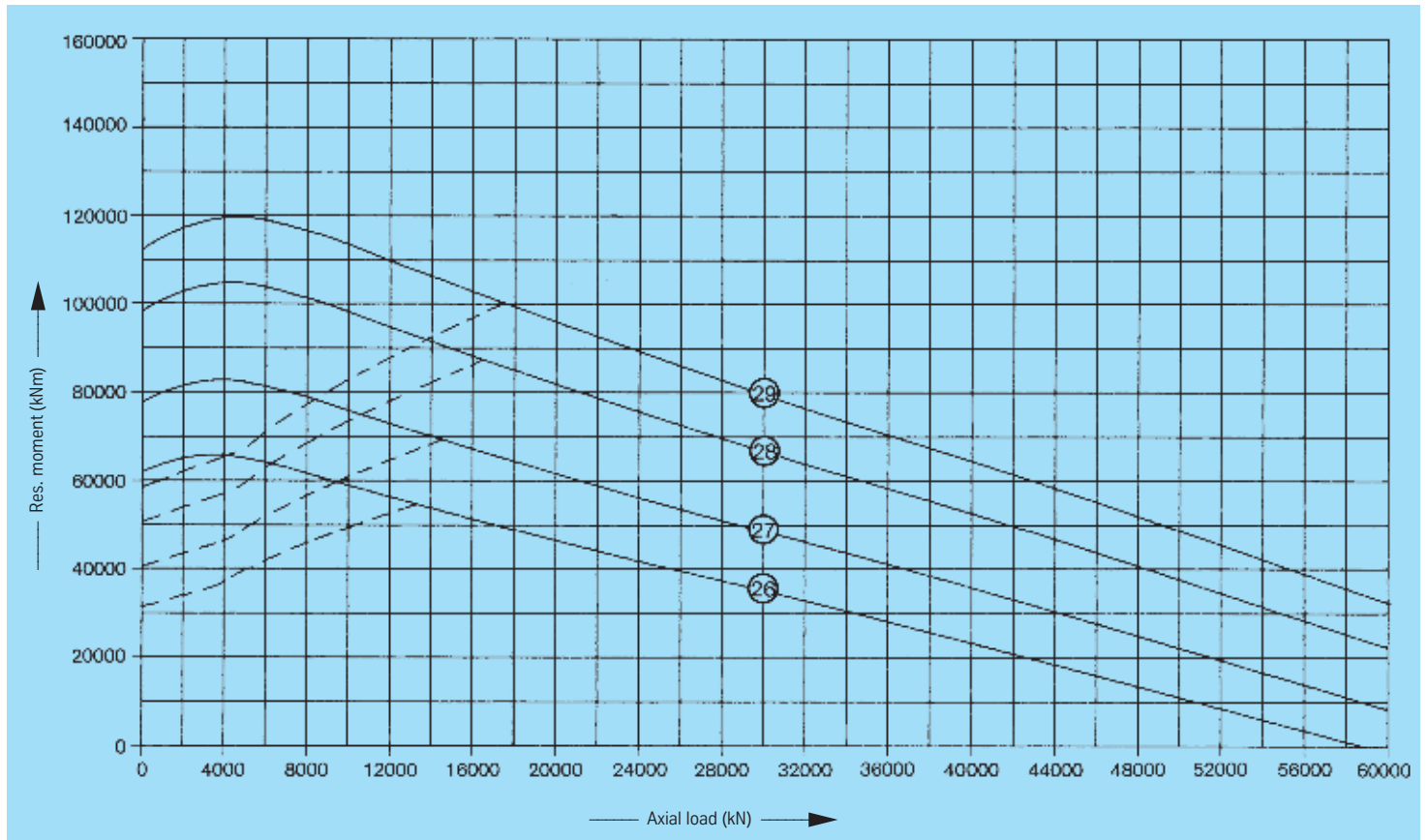

Standard series RD 900



Rothe Erde
Slewing Bearings

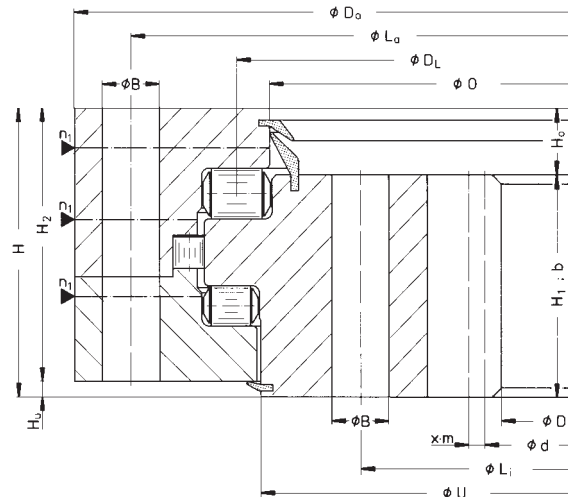
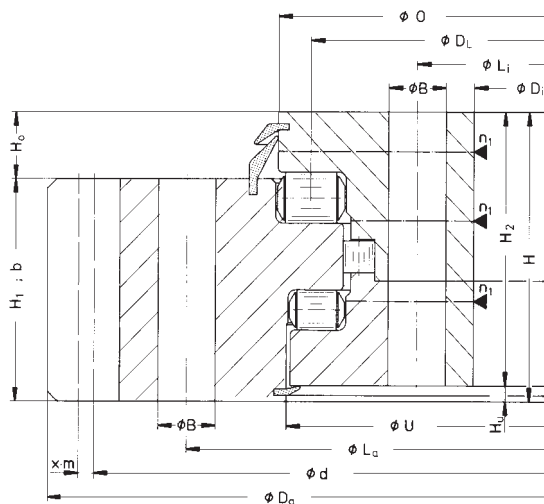

Service life curves · 30,000 revolutions

drawing position = mounting position

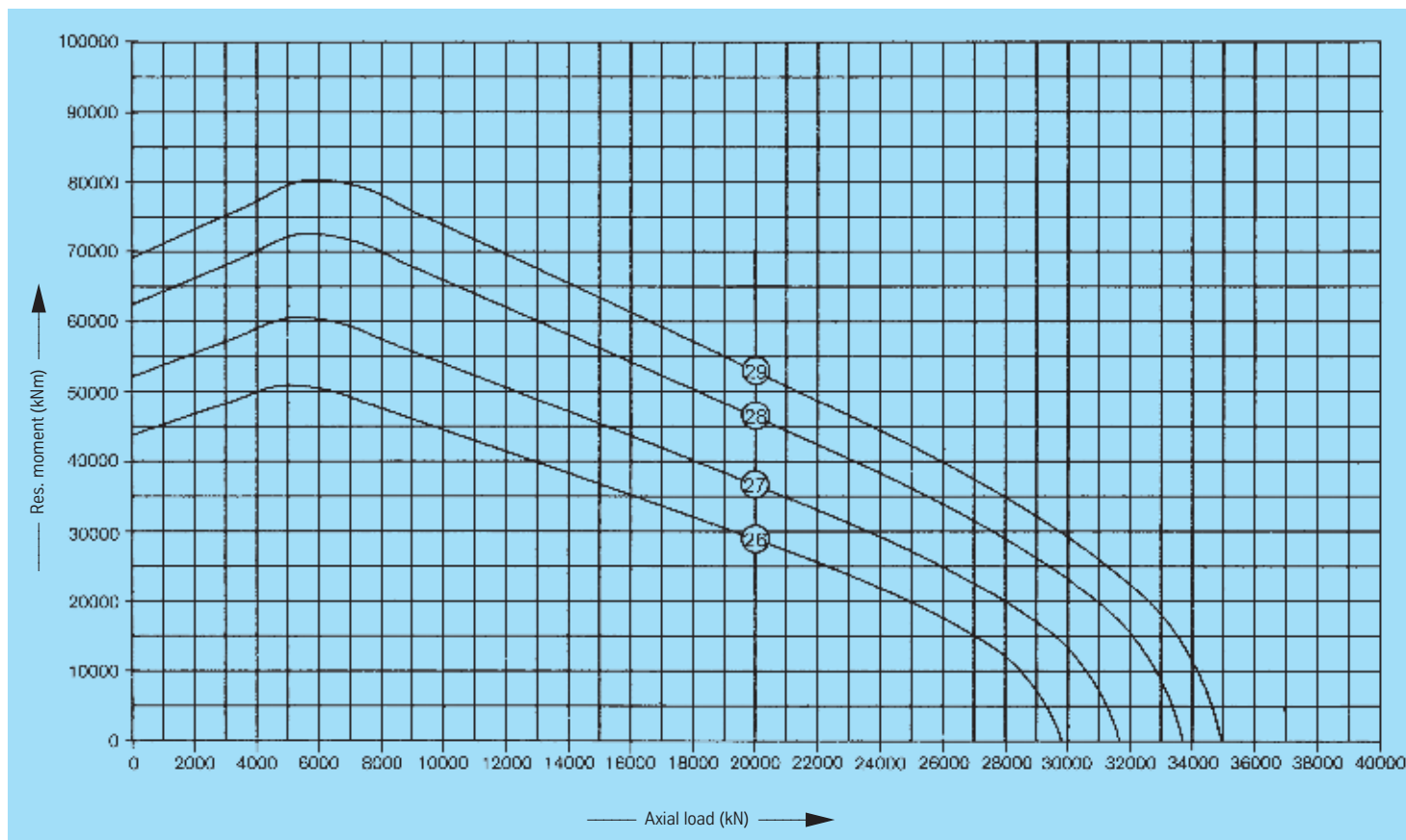

Design type variations.



Rothe Erde
Slewing Bearings

Rothe Erde large-diameter anti-friction bearings are available in a wide range of design types for specific applications.

The illustrations on this Page show some complementary examples to the standard series described in this catalogue.

For any specific requirements you may have regarding the application or operating conditions, please contact our engineers for more information.

They will be happy to give you the benefit of their expertise.

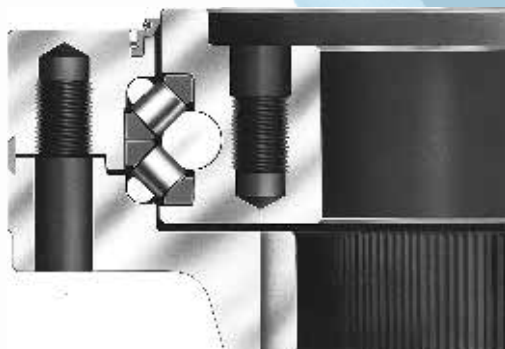
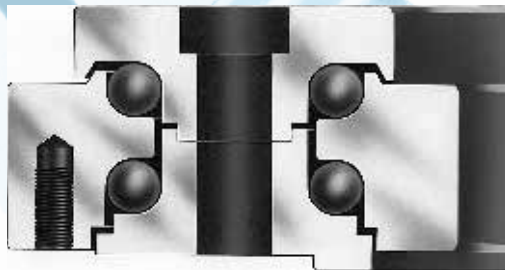
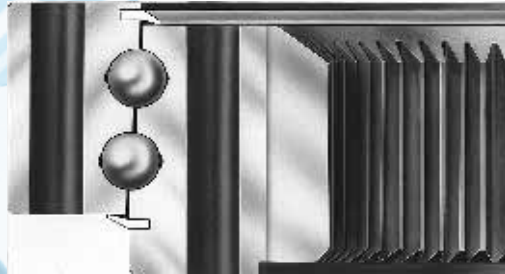
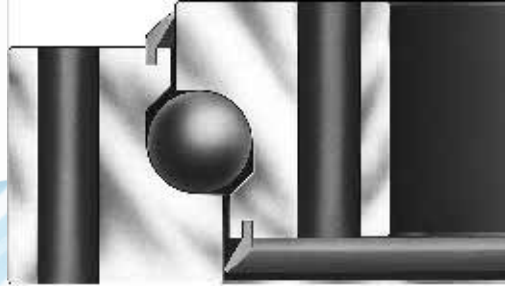



All the data and information contained in this catalogue have been carefully evaluated and checked. We do not, however, accept responsibility for any omissions or errors. We reserve the right to effect technical changes and amendments resulting from future developments without prior notice. All earlier editions are invalid with effect from the publication of this catalogue. Individual details in this information shall only then be considered the warranted characteristics when we expressly confirmed them as such in writing in each individual case.

Head Office

Rothe Erde GmbH

Tremoniastrasse 5-11
D-44137 Dortmund
Phone: +49 (2 31) 1 86 -0
Fax: +49 (2 31) 1 86 -25 00
rotheerde@thyssenkrupp.com
www.rotheerde.com

Offices in Germany

Berlin

Rothe Erde GmbH
Geschäftsstelle Berlin
gs-berlin.rotheerde@
thyssenkrupp.com

North

Rothe Erde GmbH
Geschäftsstelle Nord
gs-nord.rotheerde@
thyssenkrupp.com

South

Rothe Erde GmbH
Geschäftsstelle Süd
gs-sued.rotheerde@
thyssenkrupp.com

Subsidiaries

France

Roballo France SARL
contact@roballo-france.com

Great Britain

Roballo Engineering Co. Ltd.
info@roballo.co.uk
www.roballo.co.uk

Italy

Rothe Erde-Metallurgica
Rossi S.p.A.
mri@rotheerde.it
www.rotheerde.it

Spain

Roteisa
Rothe Erde Ibérica S.A.
roteisa@roteisa.es
www.roteisa.es

China

Xuzhou Rothe Erde
Slewing Bearing Co., Ltd.
xuzhou_rothe_erde@xreb.com
www.xreb.com

Xuzhou Rothe Erde
Ring Mill Co., Ltd.
xrem@xrem.cn

India

Rothe Erde India Private Limited
re_india@vsnl.net
www.rotheerdeindia.com

Japan

Nippon Roballo Co., Ltd.
info@roballo.co.jp
www.roballo.co.jp

Brazil

Robrasa
Rolamentos Especiais
Rothe Erde Ltda.
vendastecnicas@robrasa.ind.br
www.robrasa.ind.br

USA

Rotek Incorporated
sales@rotek-inc.com
www.rotek-inc.com



Rothe Erde

English

Deutsch

Français

Español

Português

Nederlands

Русский

中文

日本語

Rothe Erde[®] Slewing Bearings

Installation · Lubrication · Maintenance

ThyssenKrupp Rothe Erde



ThyssenKrupp



Installation · Lubrication · Maintenance (ILM)

Does not apply to bearings with specific ILM instructions

Rothe Erde offers an extensive slewing bearing service (see publication “Rothe Erde Slewing Bearing Service” or www.rotheerde.com).

Transport and handling

Slewing bearings, like any other part of a machine, require careful handling. They should always be transported and stored in horizontal position. For safe handling of bearings which include transport holes, high tensile lifting eye bolts must be used. If they have to be transported vertically, they will require internal cross bracing. The bearing weight must be indicated on the crate or pallet. Impact loads, particularly in a radial direction, must be avoided.

Delivery condition

- Raceway system
The slewing bearings are delivered filled with one of the greases (see table 3) unless no special lubricant and special grease quantities are required.
- External surfaces
External surfaces protected with Cortec VpCI 369/H10.
- Gearing
The gearing is not greased. Anti-corrosion treatment as for external surfaces.

Storage

Approx. 6 months in roofed storage areas. Approx. 12 months in enclosed, temperature-controlled areas (temperature > 12°C). Outside storage is not allowed.

Longer storage periods will necessitate special preservation. After the slewing bearing has been stored for a relatively long time, an increased frictional torque may be observed caused by the suction adhesion of the sealing lip. Careful lifting of the sealing lip with a blunt object around the entire circumference and several clockwise and counterclockwise rotations of the slewing bearing through 360 degrees will reduce the frictional torque to normal.

Installation

A flat mounting surface free of grease and oil is essential for the upper and lower ring to seat firmly. Welding beads, burrs, excessive paint and other irregularities must be removed prior to installation. The bearing rings must be completely supported by the connecting structure.

Rothe Erde recommends conducting a check on the mounting surfaces with a leveling instrument or laser equipment (this service can be provided by Rothe Erde). The flatness values should not exceed the values shown in Table 1. To avoid larger deviations and the occurrence of peaks in smaller sectors, any deviation in the range of 0° - 180° may only rise evenly once and fall again.

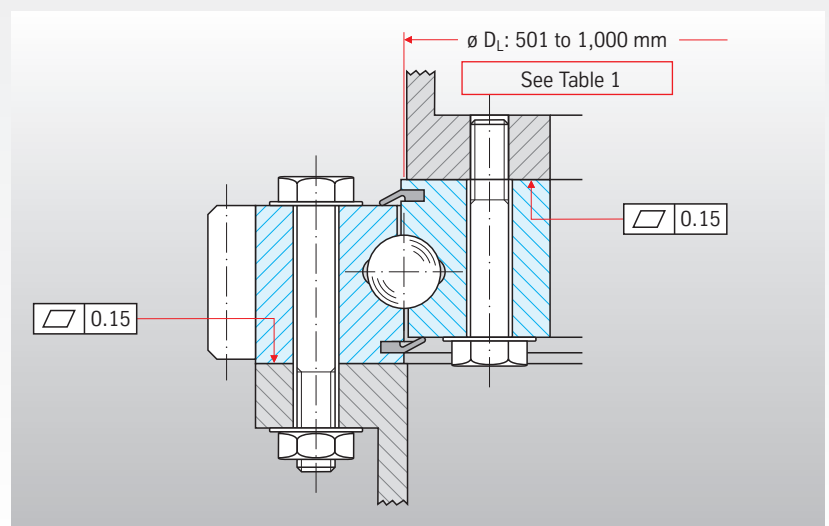

Fig. 1: Example of flatness deviation acc. to DIN EN ISO 1101

Table 1: Permitted flatness deviation acc. to DIN EN ISO 1101 on the support surfaces

Track Ø in mm D_L	Flatness acc. to DIN EN ISO 1101 per support surface in mm for		
	BF 01 Double-row ball bearing slewing rings BF 08 Axial ball bearings	BF 06 Single-row ball bearing slewing rings 4-point contact bearings BF 09 – Double 4- point contact bearings BF 25, 23, 28 profile bearings*	BF 19 BF 13 Roller slewing bearings BF 12 Combination bearings
up to 500	0.15	0.10	0.07
up to 1000	0.20	0.15	0.10
up to 1500	0.25	0.19	0.12
up to 2000	0.30	0.22	0.15
up to 2500	0.35	0.25	0.17
up to 4000	0.40	0.30	0.20
up to 6000	0.50	0.40	0.30
up to 8000	0.60	0.50	0.40

BF is the abbreviation for the german term "Bauform" (means design) and refers to the first two digits of the drawing number. The permitted values in Table 1 are not allowed to be used for special configurations as high-precision bearings with high running accuracy and low bearing play, please contact Rothe Erde: www.rotheerde.com
*) Double these values are permitted for normal bearings BF 25.

Mechanical machining of the bearing connection surfaces on the connecting structure is required if the values are exceeded. The mounting position of slewing bearings must correspond to that shown in the drawing.

The corrosion protection can be removed with an alkaline cleaner. Solvent must be prevented from coming into contact with the seals or the raceway. Remove the protective coating from the upper and the lower mounting surfaces of the slewing bearing as well as from the gear.

Note The corrosion protection can easily be removed, for example, using a biodegradable alkaline cleaner.

Advantage Rapid removal of the corrosion protection and low environmental impact.

Hardness gap

The unhardened zone between the beginning and the end of the hardened region of the raceway is marked with an "S" on the inner or outer diameter of each bearing ring. On the gear ring, the hardness gap is marked on the axial surface. Wherever possible, the hardness gap "S" must be positioned outside the main load-carrying areas. If the main working area for the application is known, then the hardness gap of the ring loaded on the circumference must also be positioned outside the main load-carrying area.

Gearing

The backlash is adjusted relative to the three gear teeth marked in green and should be at least $0.03-0.04 \times \text{module}$. After the final tightening of the bearing,



Fig. 2: Backlash measurement



Table 2

Thread/ bolt diameters	Hole diameters mm DIN EN 20 273	Tightening torques Nm for bolts in strength class $\mu_G \approx \mu_K = 0.14$			
		for hydr. + electr. M_d torque wrench 8.8	for M_d torque wrench 8.8	for hydr. + electr. M_d torque wrench 10.9	for M_d torque wrench 10.9
M 12	14	87	78	130	117
M 14	16	140	126	205	184
M 16	17.5	215	193	310	279
M 18	20	300	270	430	387
M 20	22	430	387	620	558
M 24	26	740	666	1060	954
M 27	30	1100	990	1550	1395
M 30	33	1500	1350	2100	1890
		Grade 5	Grade 5	Grade 8	Grade 8
UNC 5/8" - 11	18	200	180	286	260
UNC 3/4" - 10	21	352	320	506	460
UNC 7/8" - 9	25	572	520	803	730
UNC 1" - 8	27.5	855	770	1210	1100
UNC 1 1/8" - 7	32	1068	970	1716	1560
UNC 1 1/4" - 7	35	1507	1370	2410	2190
		Grade 5	Grade 5	Grade 8	Grade 8
UNF 5/8" - 18	18	230	210	320	290
UNF 3/4" - 16	21	396	360	560	510
UNF 7/8" - 14	25	638	580	902	820
UNF 1" - 12	27.5	946	860	1330	1210
UNF 1 1/8" - 12	32	1210	1100	1936	1760
UNF 1 1/4" - 12	35	1672	1520	2685	2440

the backlash should be rechecked over the entire circumference. A tip edge radius and a tip relief must be provided on the pinion (see the "Gearing" chapter in the Rothe Erde main catalog or www.rotheerde.com).

Bolting/bolting assembly

Bolt holes on the bearing and connecting structure must match up, otherwise impermissible levels of stress will be established. Through-holes shall be configured acc. to DIN EN 20273, medium series, – see Table 2.



Rothe Erde

Fastening bolts

Normal fastening bolts, nuts and washers (without surface treatment) in strength class 10.9 acc. to DIN ISO 267. It is essential to comply with the specified number and diameter. The bolts must be carefully preloaded crosswise to the specified values (Table 2 gives several recommended values). The surface pressure underneath the bolt head or nut must not exceed the permitted limit values (see "Fastening bolts" chapter in the Rothe Erde main catalog or www.rotheerde.com, also with regard to the minimum grip of the bolt). If the limiting surface pressure is exceeded, washers of the appropriate size and strength must be provided. The minimum length of engagement must be guaranteed in the case of blind hole threads. If a hydraulic tensioning device is used, it is essential to adhere to the required projections for the screw threads or stud bolt threads and to use the appropriate washers (see the "Bolts" chapter in the Rothe Erde main catalog or www.rotheerde.com).

The determination of the tightening torque depends not only on the strength class of the bolt and the tightening process but also on the friction in the thread and the contact surface of the bolt head and nut. The tightening torques given in Table 2 are recommended values based on lightly oiled threads and contact surfaces.

Dry threads will require higher torques whilst heavily oiled threads will require lower tightening torques. The values may, therefore, vary considerably. This applies in particular to threads larger than M 30 or 1¼". For bolts of this size the use of bolt tensioning is recommended. If the frictional bond is not adequate, it is advisable to use a suitable compound to increase the frictional bond, or else make a form-locking connection. Welding of slewing bearings is not permitted.

Lubrication and Maintenance

All the grease nipples must be easily accessible, lubrication lines must be provided if necessary. Rothe Erde recommends the installation of an automatic central lubricating system. The bearing system and the gearing must be greased immediately after installation. The lubricants specified in Table 3 are to be used for this and each subsequent lubrication. The only lubrication to be used on the raceway is KP 2 K grease, i.e. lithium saponified mineral oils of NLGI Grade 2 with EP additives. The raceway lubricants listed in Table 3 can be mixed together. The lubricants are listed in alphabetical order. The grease fill prevents friction, provides protection against corrosion and is a component of the seal.

Therefore the bearing must always be greased liberally so that a collar of fresh grease forms around the whole circumference of the bearing gap and lip seals. The bearing should be rotated during relubrication.



Lubricants







Queries about lubricants should be directed to the respective manufacturer.

The greases listed in Table 3 are approved for our slewing bearings and tested for compatibility with the materials which we use for our spacers and seals. The list of greases is not exhaustive.

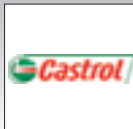
Obtain confirmation of suitability from the lubricant manufacturer before using other lubricants. The properties must at least correspond to those of the greases listed in Table 3, and compatibility with the materials we use must be assured. When automatic lubricating devices are used, the lubricant manufacturer must confirm that the lubricant selected is suitable for a “pumped” system. Special lubricants are necessary if the bearings are used in extreme temperatures.

Lubricants are contaminants. They must not be allowed to get into the ground, the ground-water, or into the water and sewage system.

Table 3: Lubricants

	●	Aralub HLP 2	243 K to 393 K (-30 °C to +120 °C)
	▲	Aralub MKA-Z 1	263 K to 453 K (-10 °C to +180 °C)
	●	Spheerol EPL 2	253 K to 413 K (-20 °C to +140 °C)
	▲	Mollub-Alloy 9790/2500-1	253 K to 363 K (-20 °C to +90 °C)
	●	Centoplex EP 2	253 K to 403 K (-20 °C to +130 °C)
	▲	Grafloscon C-SG 0 ultra	243 K to 473 K (-30 °C to +200 °C)
	●	Lagermeister EP 2	253 K to 403 K (-20 °C to +130 °C)
	▲	Ceplattyn KG 10 HMF	263 K to 413 K (-10 °C to +140 °C)
	●	Mobilux EP 2	253 K to 393 K (-20 °C to +120 °C)
	▲	Mobilgear OGL 461	253 K to 393 K (-20 °C to +120 °C)
	●	Gadus S2 V220 2	248 K to 403 K (-25 °C to +130 °C)
	▲	Malleus OGH	263 K to 473 K (-10 °C to +200 °C)
	●	Multis EP 2	248 K to 393 K (-25 °C to +120 °C)
	▲	Ceran AD Plus	248 K to 423 K (-25 °C to +150 °C)

● Raceway grease

▲ Gear grease

Relubrication of the raceway system

The bearing should be rotated during relubrication until a fresh collar of grease is seen to form around the whole circumference of the bearing gaps and lip seals. It is the responsibility of the maintenance personnel to ensure that the correct amounts of grease at individual regular intervals are administered to the bearing, determined by regular monitoring of the lubricated condition of both the bearing raceway and gear. The amount of lubrication will need to be increased and the lubrication intervals shortened in extreme conditions, e.g. in the tropics, where humidity levels (moisture) are raised, exposure to dust and dirt is high, and extreme temperature fluctuations prevail.

Bogie bearings for railway and tram vehicles as well as bearings for wind energy turbines are subject to special requirements, and Rothe Erde should be contacted in such cases.

In the case of partially assembled bearings, or if there is a long period between bearing installation and equipment commissioning, then appropriate maintenance procedures will be required, e.g. relubrication under rotation or adequate slewing after no more than three months and thereafter every three months. Relubrication is absolutely essential before and after prolonged shutdown of the equipment.

Cleaning the equipment

When cleaning the equipment, care must be taken to prevent cleaning agents or water from damaging the seals or penetrating into the raceways.

Lubrication intervals for the gear

We recommend automatic gear lubrication. This is because the tooth flanks should always have sufficient grease applied relative to both the application and the duty. It is the responsibility of the maintenance personnel to ensure that the correct amounts of grease at individual regular intervals are administered to the gearing, determined by regular monitoring of the lubricated condition.

Note Effective lubrication is essential for the raceway system and the gearing. This is the only way to achieve a satisfactory service life.

Advantage Optimum use of lubricant and intervals increase the availability of the system.

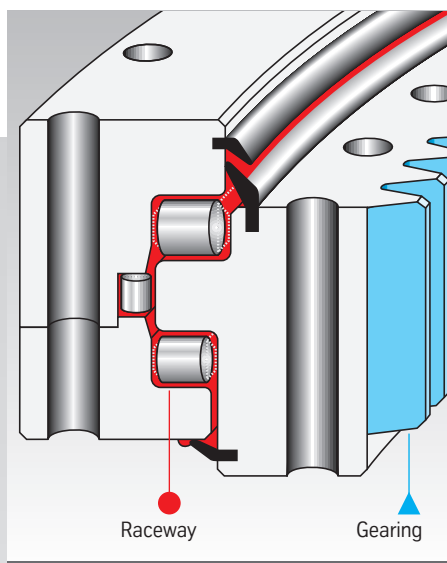

Fig. 3

Examination of bolts

The bolted connection must be capable of maintaining a pre-designated preload during the entire life of the bearing. Experience has shown that it is advisable to check the bolt torques on a regular basis and to retighten the bolts to compensate for any settlement phenomena.

Checking of the raceway system

When the bearing is put into operation, we recommend that tilting play or subsidence should be measured (see the "Bearing inspection" chapter in the Rothe Erde main catalog or www.rotheerde.com). Make sure that the wear limits of the bearing are not reached. We recommend repeating this measurement at suitable intervals. In addition, a sample of the used grease can be taken for analysis.

Checking of the seal

Check seals at least every 6 months, renew the seal if it is damaged.

Disposal at end of useful life

Bearing to be dismantled. Grease, seals and plastic parts to be disposed of in accordance with waste guidelines. Bearing rings and rolling elements to be taken to the relevant material recycling points.

Rothe Erde[®] Worldwide

Headoffice

Headoffice Dortmund

ThyssenKrupp Rothe Erde GmbH
Tremoniastrasse 5-11
44137 Dortmund, Germany
Telephone +49 (2 31) 1 86-0
Telefax +49 (2 31) 1 86-25 00
rotheerde@thyssenkrupp.com
www.thyssenkrupp-rotheerde.com

Plants

Dortmund plant

ThyssenKrupp Rothe Erde GmbH
Tremoniastrasse 5-11
44137 Dortmund, Germany
Telephone +49 (2 31) 1 86-0
Telefax +49 (2 31) 1 86-25 00

Lippstadt plant

ThyssenKrupp Rothe Erde GmbH
Beckumer Strasse 87
59555 Lippstadt, Germany
Telephone +49 (29 41) 7 41-0
Telefax +49 (29 41) 7 41-33 20

Eberswalde plant

ThyssenKrupp Rothe Erde GmbH
Heegermühler Strasse 64
16225 Eberswalde, Germany
Telephone +49 (33 34) 2 06-4 00
Telefax +49 (33 34) 2 06-4 90

Branch offices in Germany

Berlin

ThyssenKrupp Rothe Erde GmbH
Geschäftsstelle Berlin
gs-berlin.rotheerde@
thyssenkrupp.com

North

ThyssenKrupp Rothe Erde GmbH
Geschäftsstelle Nord
gs-nord.rotheerde@
thyssenkrupp.com

South

ThyssenKrupp Rothe Erde GmbH
Geschäftsstelle Süd
gs-sued.rotheerde@
thyssenkrupp.com

Subsidiaries

France

Roballo France SARL
contact@roballo-france.com

Great Britain

Roballo Engineering Co. Ltd.
info@roballo.co.uk
www.roballo.co.uk

Italy

Rothe Erde-Metallurgica
Rossi S.p.A.
mri@thyssenkrupp.com
www.rotheerde.it

Spain

Roteisa
Rothe Erde Ibérica S.A.
roteisa@roteisa.es
www.roteisa.es

China

Xuzhou Rothe Erde
Slewing Bearing Co., Ltd.
xuzhou_rothe_erde@xreb.com
www.xreb.com

Xuzhou Rothe Erde
Ring Mill Co., Ltd.
xrem@xrem.cn

India

Rothe Erde India Private Limited
info.rotheerdeindia@
thyssenkrupp.com
www.rotheerdeindia.com

Japan

Nippon Roballo Co., Ltd.
info@roballo.co.jp
www.roballo.co.jp

Brazil

Robrasa
Rolamentos Especiais
Rothe Erde Ltda.
vendas.robраса@
thyssenkrupp.com
www.robраса.com.br

USA

Rotek Incorporated
sales@rotek-inc.com
www.rotek-inc.com



Rothe Erde

Individual details in this document shall only be considered a quality and/or durability guarantee if expressly confirmed by us in writing on a case-by-case basis. This publication must not be reproduced in whole or in part without permission. All rights reserved. Printed in Germany.



ThyssenKrupp Rothe Erde GmbH

Tremoniastrasse 5-11 · 44137 Dortmund · Germany
Telephone +49 (231) 186-0 · Telefax +49 (231) 186-2500
rotheerde@thyssenkrupp.com · www.thyssenkrupp-rotheerde.com

English

Deutsch



Rothe Erde[®] Slewing Bearings

Bearing Inspection

ThyssenKrupp Rothe Erde



ThyssenKrupp



Bearing inspection

Preventing damage

Wear measurements enable early detection of technical problems before they result in unscheduled plant stoppages. Unnecessary repair costs and expensive production downtimes are thus avoided. We therefore recommend regular bearing wear measurements in order to assess the condition of a bearing.

The wear which affects the raceway system makes itself felt in a change of the axial motion or the axial reduction. Depending on the application or bearing version, this increase in wear can be determined by measuring the tilting clearance or by taking reduction measurements.

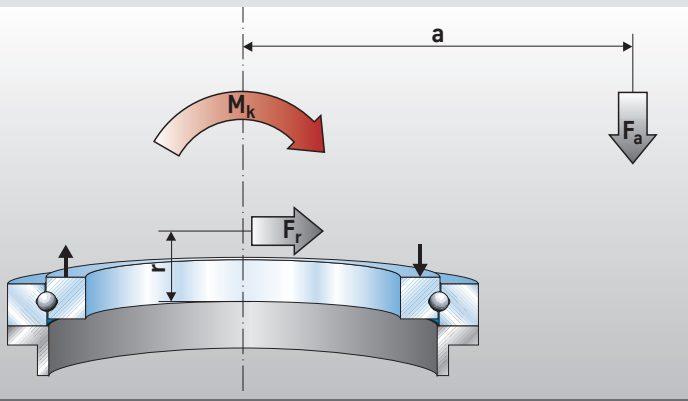

Figure 1: Loading principle of the tilting clearance measurement (axial motion)

Measuring the tilting clearance

To determine the wear, we recommend carrying out tilting clearance measurements wherever possible. The loading principle for such measurements is shown in figure 1.

The measurements are taken between the lower companion structure and the bearing ring which is bolted to the superstructure (figure 2). The measurements must be taken as close to the raceway system as possible in order to minimize the impact of elastic deformations in the companion structure.

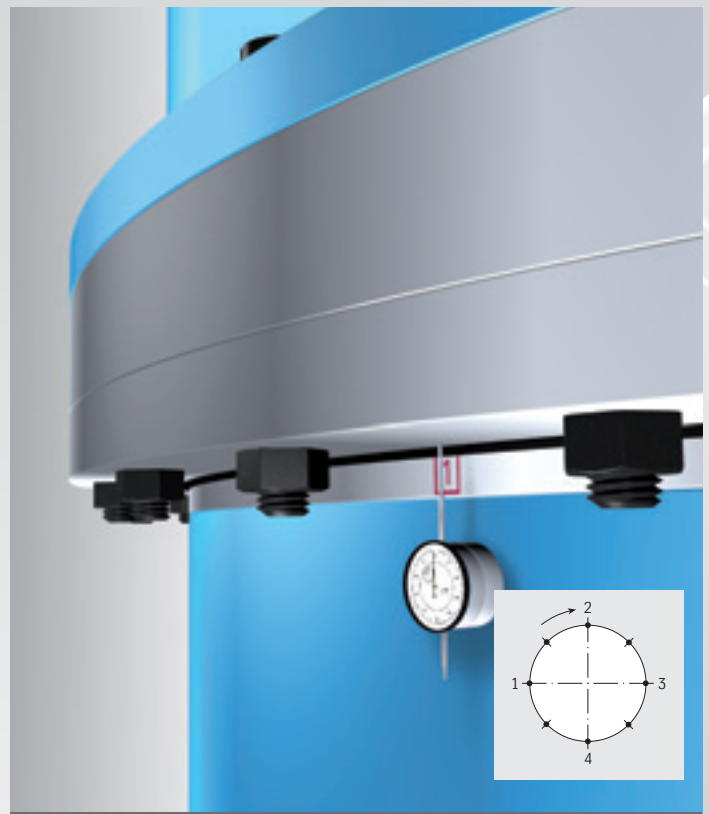

Figure 2: Basic setup for measuring the tilting clearance

The procedure is as follows:

- Take a reference measurement when the equipment is put into operation.
- Mark the measuring points around the circumference starting from a defined position.
- First apply the maximum retrograde moment in order to set the dial gauges to zero (the gauges must have a measuring accuracy of 0.01 mm). Then apply a forward tilting moment, with load uptake if necessary.
- Swivel the superstructure and repeat the measurements at the marked measuring points (see table 4 on page 9).



Maximum permissible increase in bearing clearance (uniform wear)

These increases in bearing clearance are not permissible for special applications, e.g. 50% of the listed values for fairground ride slewing bearings (contact ThyssenKrupp Rothe Erde).

Table 1: BF* 01, 08 (double-row ball bearings/axial ball bearings)

Measuring method	Ball diameter mm										
	18	20	22	25	30	35	40	45	50	60	70
	max. permissible wear values up to mm										
Axial reduction measurement	1.8			2.2			3.0			3.8	
Tilting clearance measurement	2.5			3.0			4.0			5.0	

*BF = design type (see www.thyssenkrupp-rotheerde.com)

Table 2: BF* 06, 09, 25, 23, 28 (ball bearings/profile bearings)

Measuring method	Ball diameter mm										
	20	22	25	30	35	40	45	50	60	70	
	max. permissible wear values up to mm										
Axial reduction measurement	1.6		2.0			2.6			3.3		
Tilting clearance measurement	2.0		2.6			3.2			4.0		

*BF = design type (see www.thyssenkrupp-rotheerde.com)

Table 3: BF* 12, 13, 19 (roller bearing slewing rings)

Measuring method	Roller diameter mm													
	16	20	25	28	32	36	40	45	50	60	70	80	90	100
	max. permissible wear values up to mm													
Axial reduction measurement	0.8		1.2			1.6			2.0			2.4		
Tilting clearance measurement	1.4		2.0			2.8			3.5			4.2		

*BF = design type (see www.thyssenkrupp-rotheerde.com)

Inspecting the gearing

Gear teeth become smoothed and worn in the course of use. A permissible wear limit depends very much on the application. Experience indicates that a wear value of up to 0.1 x module per flank is permissible.



Measuring the axial reduction

Where tilting clearance measurements are not possible we recommend the axial reduction measurement method. In this case the center of the load combinations lies within the race diameter of the bearing. The loading principle is shown in figure 3.

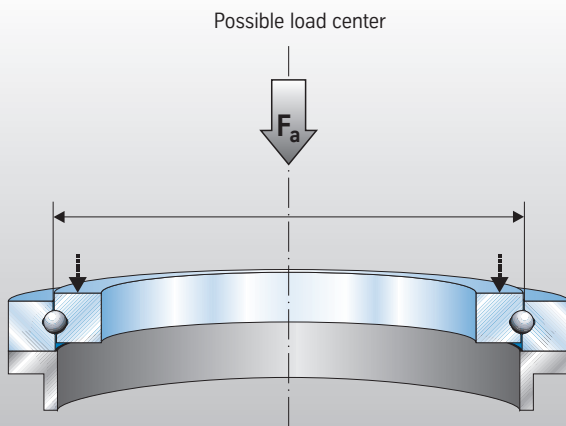

Figure 3: Loading principle of the axial reduction measurement

The measurements are taken between the lower companion structure and the bearing ring which is bolted to the superstructure (figures 4, 5). The procedure is similar to that for measuring the tilting clearance:

- Here too, record reference values when the equipment is put into operation.
- Mark the measuring points around the circumference starting from a defined position.

Repeat the tilting clearance or axial reduction measurements under the same conditions at appropriate intervals, after first checking the bearing fastening bolts. The difference between the current measurement and the reference measurement is the wear which has occurred in the intervening period. If the wear values show a rising trend, you should carry out the measurements more often.

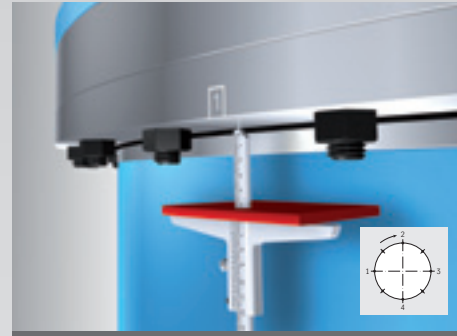

Figure 4: Basic setup for measuring the axial reduction with a depth gauge

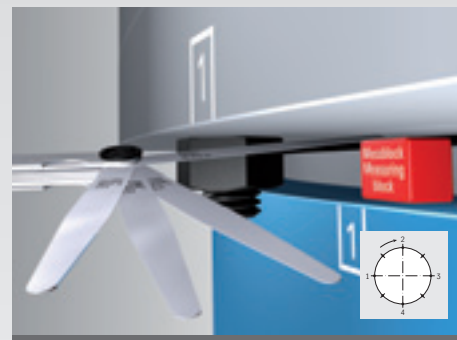

Figure 5: Basic setup for measuring the axial reduction with a feeler gauge

Advantage Given conclusive assessment of the bearing's condition, worn parts can be replaced in good time.

In conjunction with optimum spare parts management, it is thus possible to avoid incidents of damage and lengthy downtimes.

Note If the permissible wear values (tables 1, 2 and 3 on page 3) are exceeded, we recommend that the equipment should be shut down.



**The alternative:
IWM (integrated wear measuring device)**

ThyssenKrupp Rothe Erde always focuses on developing innovative solutions for permanently monitoring the condition of a bearing in order to further optimize the function and reliability of plant operations. The integrated wear measuring device for slewing bearings is a patented invention which enables online inspection of the maximum permissible axial clearance or axial reduction of a slewing connection.

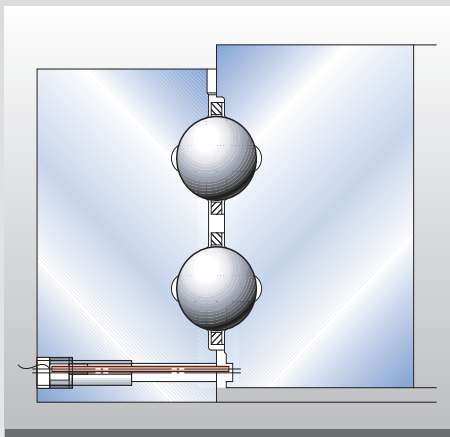

Figure 6

Advantage It is no longer necessary to interrupt operations in order to determine the axial clearance.

A pin made of stainless steel is located in the peak load area of the raceways. The electrically isolated pin is mounted in one ring and protrudes into a groove in the other ring. The maximum tolerated clearance can be adjusted by means of the groove width.

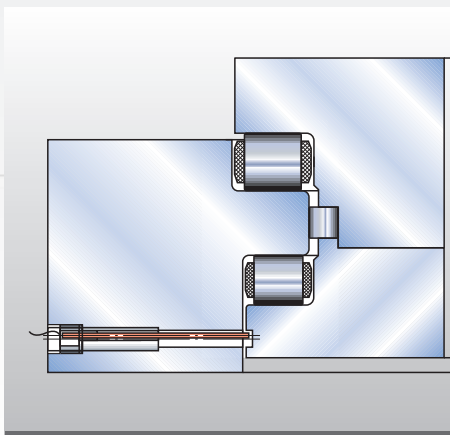

Figure 7

If the clearance changes by an impermissible amount, the ring and the pin will make contact with each other. The pin's electrical connection results in a signal being triggered when the pin touches the other ring. This signal indicates that the permissible relative movement of the rings has been reached and that it is time to inspect the bearing.

Advantage The deformation of the companion structure and the elasticity of the bolt connections do not significantly influence the measurement result. The elastic approximation of the raceways, the axial clearance of the bearing and the out-of-flatness of the contact surface are compensated. Costs for maintenance personnel are minimized.



Figure 8: Grease sampling set

Grease sampling set

Grease samples are taken in parallel with, i.e. at the same time as, the inspection measurements. The analysis of the used grease provides additional information about the raceway condition.

Bearings with grease sampling ports

The grease sampling set comprises a plastic tube, various cap plugs, a suction device, a sample box for up to 5 grease samples, and an information sheet. The procedure is described in detail.

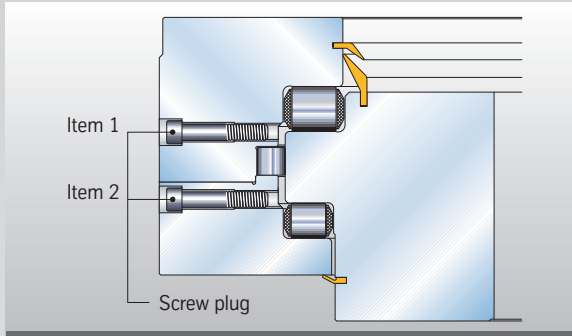

Figure 9: Three-row roller bearing slewing ring with grease sampling ports

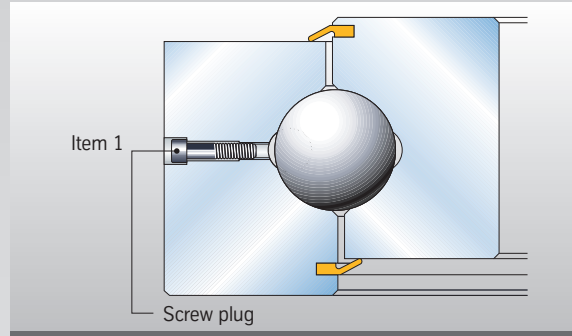

Figure 10: Single-row ball bearing with grease sampling port

Take the grease samples from the main loading zone.

Remove the screw plug (M16 EN ISO 4762) selected for taking the sample: item 1 and if necessary item 2 opposite (figures 9 and 10).

Before taking the grease sample, cut the supplied tube at an angle of 45° so that it is slightly longer than the grease sampling port. Then insert the tube into the raceway area of the port (figure 11).

Make sure that the surface cut at 45° faces in the opposite direction to the direction of rotation (figure 12).

The sampling ports must be closed again with the screw plugs.

When the sample has been taken, close both tube ends with the plastic caps.

Number the grease sample and place it in the labeled sample box.

Add the necessary information (see the grease sampling set in figure 8) to the top of the sample box.

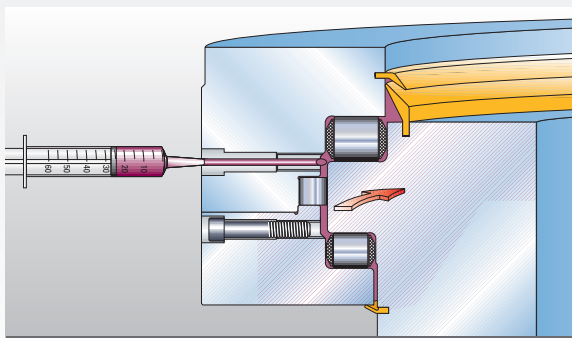

Figure 11: Taking a sample

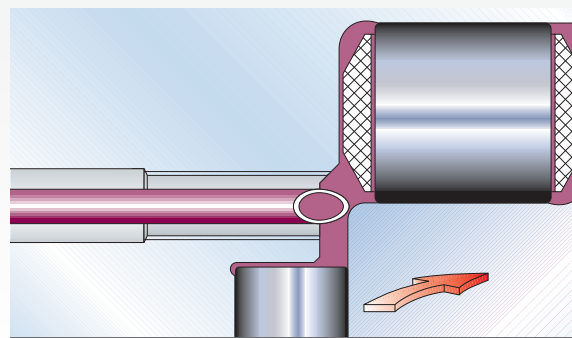

Figure 12: Detail of the sampling



Bearings without grease sampling ports

If there are no grease sampling ports provided on the bearing, one or more grease samples are taken at the seal. This area near a grease nipple must be cleaned. The sample should be taken preferably in the main working area and/or offset 180° to it.

During regreasing at the prepared grease nipple (without rotation of the bearing), the first grease escaping from the sealing lip is taken as the sample (figure 13). 3 ccm are enough.

Note Be careful when taking the sample or the result may be falsified by contamination.



Figure 13: Taking a sample of grease from the sealing lip

Fe limit values

A limit value for Fe contamination in the lubricant depends greatly on the operating parameters and the lubrication intervals. Depending on the application, the value can be as high as 20,000 ppm.

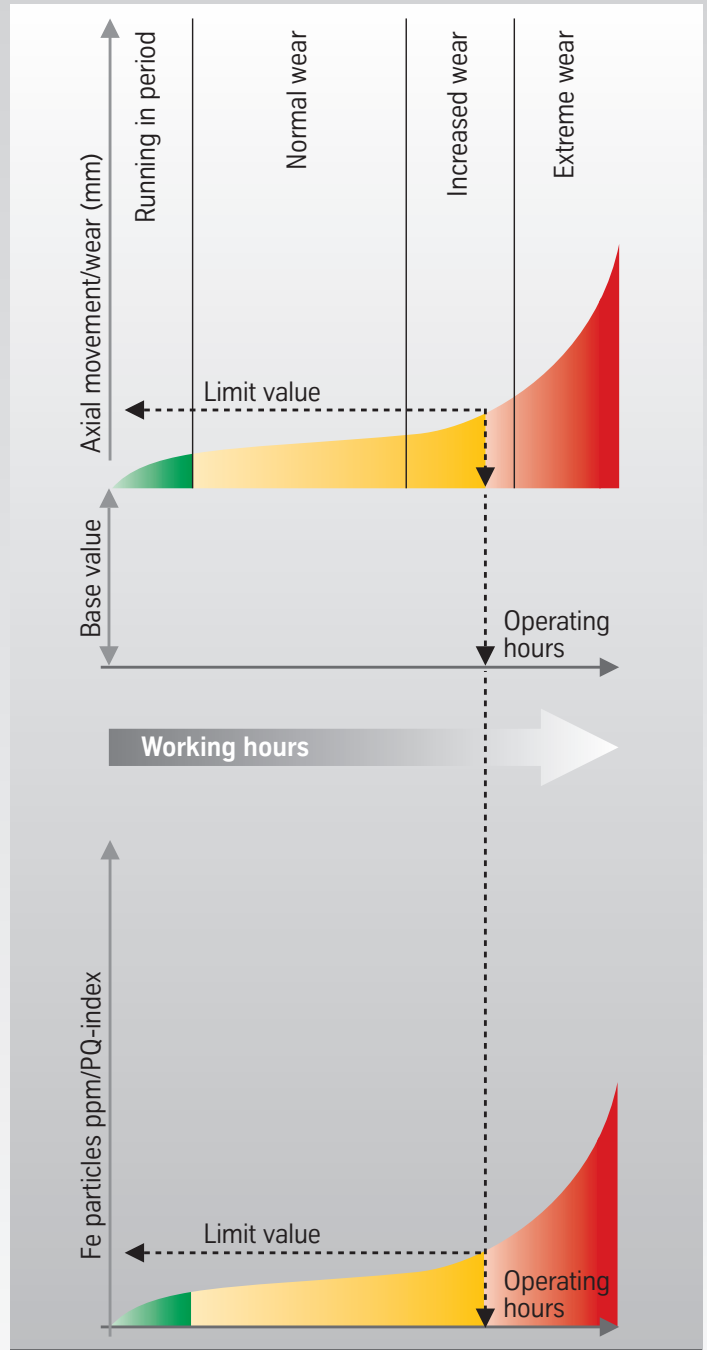

Figure 14: Wear curves

Wear curves

The diagrams show the increase in wear and the increases in Fe particles and the PQ index as a function of the operating hours (figure 14).

For standard applications see the values in tables 1-3 on page 3. When the limit values are reached, please contact ThysseKrupp Rothe Erde.



Table 4: Measurement table

Customer:		Application:					Location:	
RE drawing no.:		RE order no.:					Year of manufacture:	
Date								
Operating hours	0							
Measuring point	Basic measurement	Repeated measurement (12 months interval)						
		1	2	3	4	5	6	7
1	Main load area 180° opposite							
2	Main load area 180° opposite							
3	Main load area 180° opposite							
4	Main load area 180° opposite							
Grease sample no. Fe particles ppm/ PQ index	1							
	2							
	3							
	4							
	5							
Grease								
Lubrication system								
Quantity/interval								
Comments								

The measurement values, analysis values and bearing-specific information should be entered in a separate table (see table 4) and forwarded to ThyssenKrupp Rothe Erde.

ThyssenKrupp Rothe Erde GmbH
 Service
 Beckumer Strasse 87
 59555 Lippstadt
 Germany
 service.rotheerde@thyssenkrupp.com

For the **grease sampling set** please contact the following address:

ThyssenKrupp Rothe Erde GmbH
 Tremoniastrasse 5–11
 44137 Dortmund
 Germany
 Telephone +49 (2 31) 1 86 - 0
 Telefax +49 (2 31) 1 86 - 25 00
 sales.rotheerde@thyssenkrupp.com

ThyssenKrupp Rothe Erde sends the grease samples to an approved, qualified laboratory.

Advantage Short processing time and notification by e-mail about the analysis results and wear measurement.



Rothe Erde®

Slewing bearings in action Großwälzlager im Einsatz



ThyssenKrupp Rothe Erde

worldwide

weltweit

Headoffice Hauptverwaltung

Headoffice Dortmund

ThyssenKrupp Rothe Erde GmbH
Tremoniastrasse 5–11
44137 Dortmund, Germany
Telephone +49 (2 31) 1 86 -0
Telefax +49 (2 31) 1 86 -25 00
rotheerde@thyssenkrupp.com
www.thyssenkrupp-rotheerde.com

Plants Werke

Dortmund plant

ThyssenKrupp Rothe Erde GmbH
Tremoniastrasse 5–11
44137 Dortmund, Germany
Telephone +49 (2 31) 1 86 -0
Telefax +49 (2 31) 1 86 -25 00

Lippstadt plant

ThyssenKrupp Rothe Erde GmbH
Beckumer Strasse 87
59555 Lippstadt, Germany
Telephone +49 (29 41) 7 41 -0
Telefax +49 (29 41) 7 41 -33 20

Eberswalde plant

ThyssenKrupp Rothe Erde GmbH
Heegermühler Strasse 64
16225 Eberswalde, Germany
Telephone +49 (33 34) 2 06 -4 00
Telefax +49 (33 34) 2 06 -4 90

Branch offices in Germany Geschäftsstellen in Deutschland

Berlin

ThyssenKrupp Rothe Erde GmbH
Geschäftsstelle Berlin
gs-berlin.rotheerde@
thyssenkrupp.com

North

ThyssenKrupp Rothe Erde GmbH
Geschäftsstelle Nord
gs-nord.rotheerde@
thyssenkrupp.com

South

ThyssenKrupp Rothe Erde GmbH
Geschäftsstelle Süd
gs-sued.rotheerde@
thyssenkrupp.com

Subsidiaries Tochtergesellschaften

France

Roballo France SARL
contact@roballo-france.com

Great Britain

Roballo Engineering Co. Ltd.
info@roballo.co.uk
www.roballo.co.uk

Italy

Rothe Erde-Metallurgica
Rossi S.p.A.
mri@thyssenkrupp.com
www.rotheerde.it

Spain

Roteisa
Rothe Erde Ibérica S.A.
roteisa@roteisa.es
www.roteisa.es

China

Xuzhou Rothe Erde
Slewing Bearing Co., Ltd.
xuzhou_rothe_erde@xreb.com
www.xreb.com

Xuzhou Rothe Erde
Ring Mill Co., Ltd.
xrem@xrem.cn

India

Rothe Erde India Private Limited
info.rotheerdeindia@
thyssenkrupp.com
www.rotheerdeindia.com

Japan

Nippon Roballo Co., Ltd.
info@roballo.co.jp
www.roballo.co.jp

Brazil

Robrasa
Rolamentos Especiais
Rothe Erde Ltda.
vendas.robasa@
thyssenkrupp.com
www.robasa.com.br

USA

Rotek Incorporated
sales@rotek-inc.com
www.rotek-inc.com

Picture credits: Page 18: Herrenknecht AG, Leander Jahoda.

Individual details in this document shall only be considered a quality and/or durability guarantee if expressly confirmed by us in writing on a case-by-case basis. This publication must not be reproduced in whole or in part without permission. All rights reserved. Printed in Germany.

Bildnachweis: Seite 18: Herrenknecht AG, Leander Jahoda.

Einzelne Angaben in dieser Information gelten nur dann als Beschaffenheits- bzw. Haltbarkeitsgarantie, wenn sie von uns jeweils im Einzelfall ausdrücklich als solche schriftlich bestätigt wurden. Nachdruck, auch auszugsweise, ohne Genehmigung nicht gestattet. Alle Rechte vorbehalten. Printed in Germany.



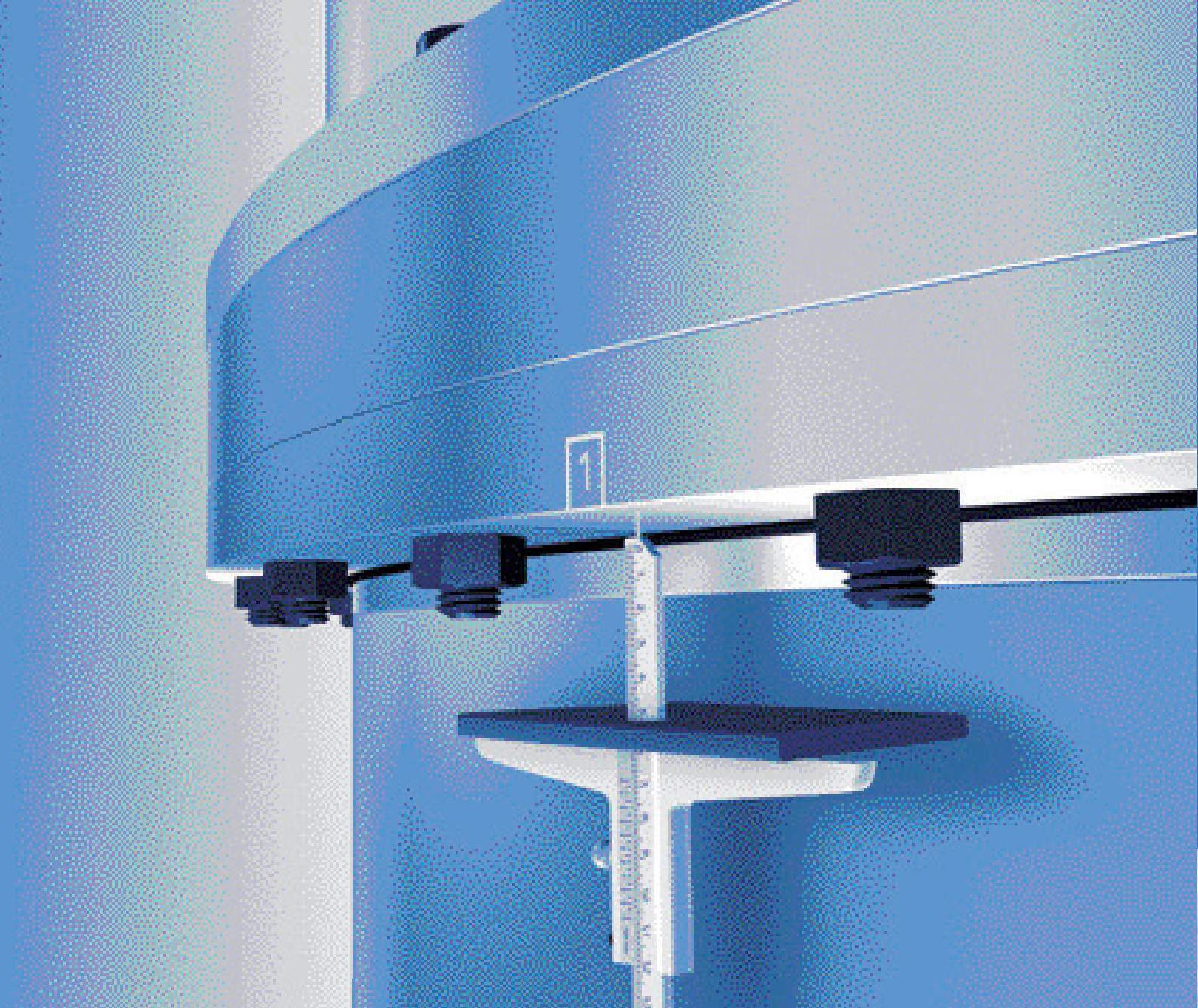

ThyssenKrupp Rothe Erde GmbH

Tremoniastrasse 5–11 · 44137 Dortmund · Germany
Telephone +49 (231) 186-0 · Telefax +49 (231) 186-2500
rotheerde@thyssenkrupp.com · www.thyssenkrupp-rotheerde.com