

KABELSCHLEPP

the power to innovate

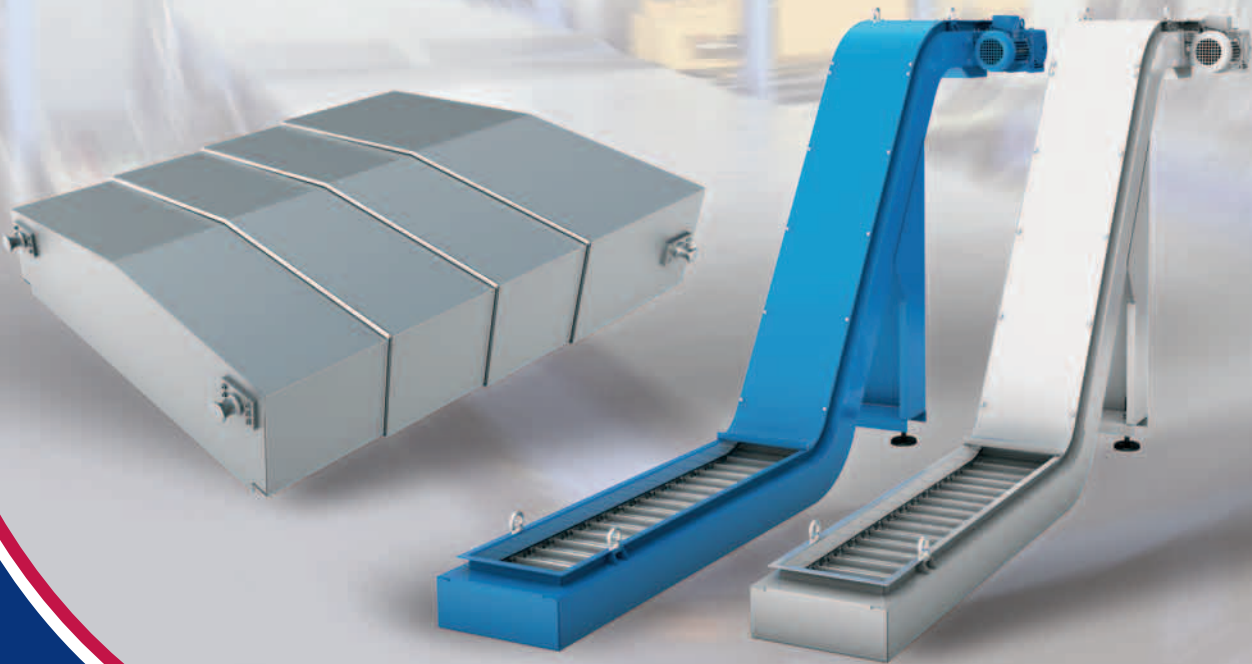

Safe. Clean. Reliable.

Guideway Protection and Conveyor Systems.

Do stop by our page on the Internet:
www.kabelschlepp.de



Copyright

Illustrations and text in this catalog are purely informative and, in part, only exemplary.

They do not represent any quality guarantee and do not assure suitability for a particular application.

This catalog is subject to technical and optical changes. Orders to be placed in the future are subject to the legally agreed quality of the relevant product, or otherwise the quality of each product as it was at the time of the signing of the contract.

All rights of this catalog are reserved, including text and illustrations, as well as brand names and corporate logos/trademarks used, in particular the rights of photocopying, distribution, translation or any other form of editing as well as the right of public reproduction.

No part of this catalog, including brand names and corporate logos/trademarks may be reproduced, processed, photocopied or distributed in any form or by any means, especially optical, photo-mechanical, paper-based or electronic, without prior written permission of KABELSCHLEPP GmbH.

Except hereof is the legally authorized use of photo-copying for merely private purposes (paragraph 53 German copyright law)

Our current terms and conditions of sales and delivery can be found at www.kabelschlepp.de

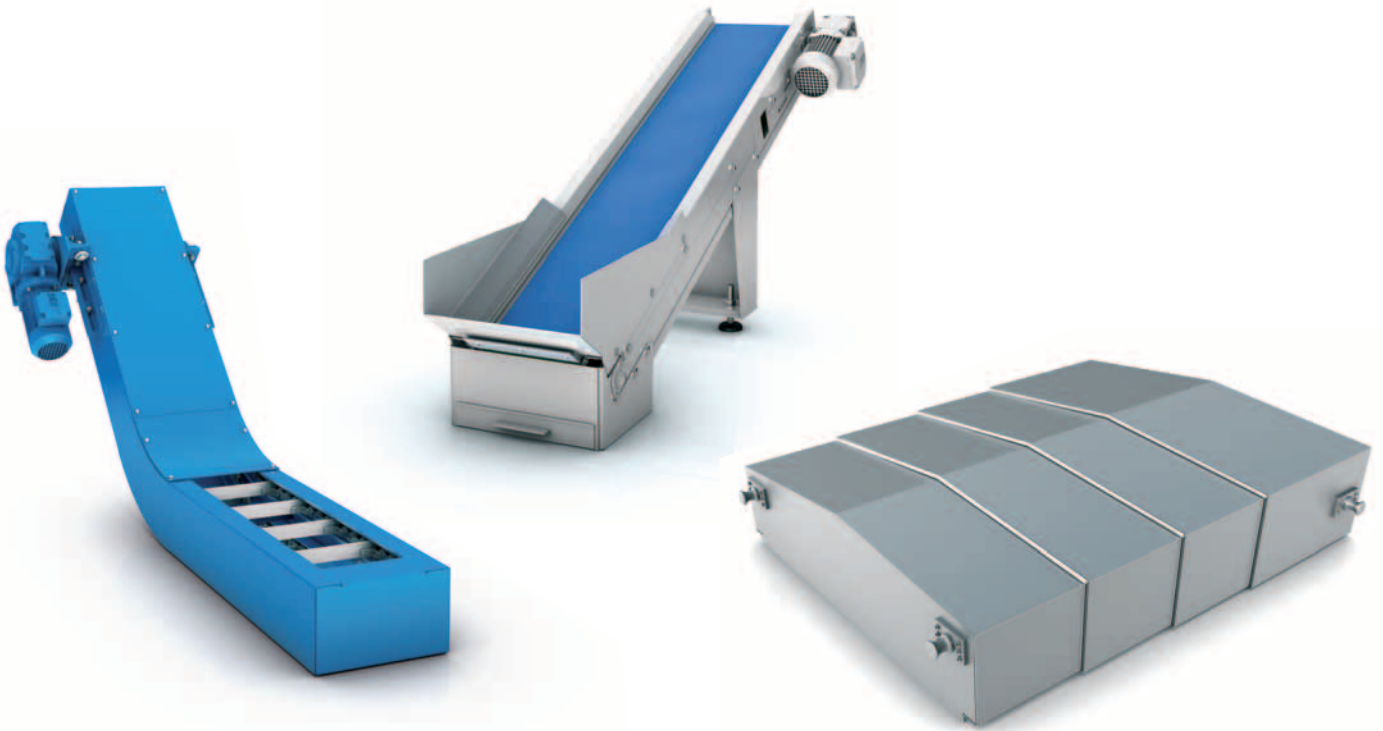

CONTENTS



	Page
Conveyor systems	7
Hinged belt conveyors	10
Scraper conveyors	16
Belt conveyors	20
Guideway protection systems	23
Telescopic covers	24
Way wipers	40
Link apron covers	49
Bellows	53
Conical spring covers	55
Roll-up covers	58
Machine housings	61
PROTECT-PANEL	62
Enquiry forms	69

The motion advantage.

Pioneering innovations make it possible.

KABELSCHLEPP – that is motion. Motion as a principle of continuous development, a never-ending series of new inventions. Just like our product range.

KABELSCHLEPP supplies reliable complete solutions covering all aspects of motion and transport for your machines.

Global Player from Germany

10 subsidiary companies, representations in 40 countries and an unchallenged position as one of the technology leaders make us successful globally.

Our global sales network ensures not only fast delivery, but also that we are always close to you and always reachable.



■ The group of companies' headquarters in Siegen. This is where worldwide experience and know-how come together.

From standard to customized

Where not only standard products, but also customer-specific solutions are the order of

the day, being close to the customer is not just empty words, but a way of life.



Service is one of our greatest priorities

We are available for you 24 hours a day. Because our service department is oriented towards your requirements: If your production is down only because a conveyor system or a telescopic cover is out of order, then we can give you quick, reliable help.

It is often most advantageous to repair the equipment, since generally custom-manufactured items are involved. Our service technicians are familiar with many different manufacturers, and are thus able to get your production up and running very quickly.

- Installation, maintenance and repair right at your location
- Large repairs and general overhauls at our Service Center in Hünsborn, Germany
- Quick delivery of spare parts
- Training your personnel for maintenance and small repairs
- Specimen construction and manufacture of prototypes



■ KABELSCHLEPP Service Center Hünsborn



■ Repair stands in Hünsborn

SERVICE HOTLINE: +49 (0) 27 62/9 74 20 · www.kabelschlepp-service.de

Efficient and flexible thanks to modern manufacturing organisation

Efficiency – that is the key word that guides our entire company. A challenge that is part of the 21st century, and a challenge that we are eager to meet.

Our production facility for protection and conveyor systems is one of the most modern in Europe.

Constant investments in the most modern manufacturing systems and the expansion of our production areas to approximately 3500 m² give you very visible benefits:

- Top quality
- Short delivery times
- An excellent price/performance ratio







Conveyor systems.

Reliability and experience based on tradition.

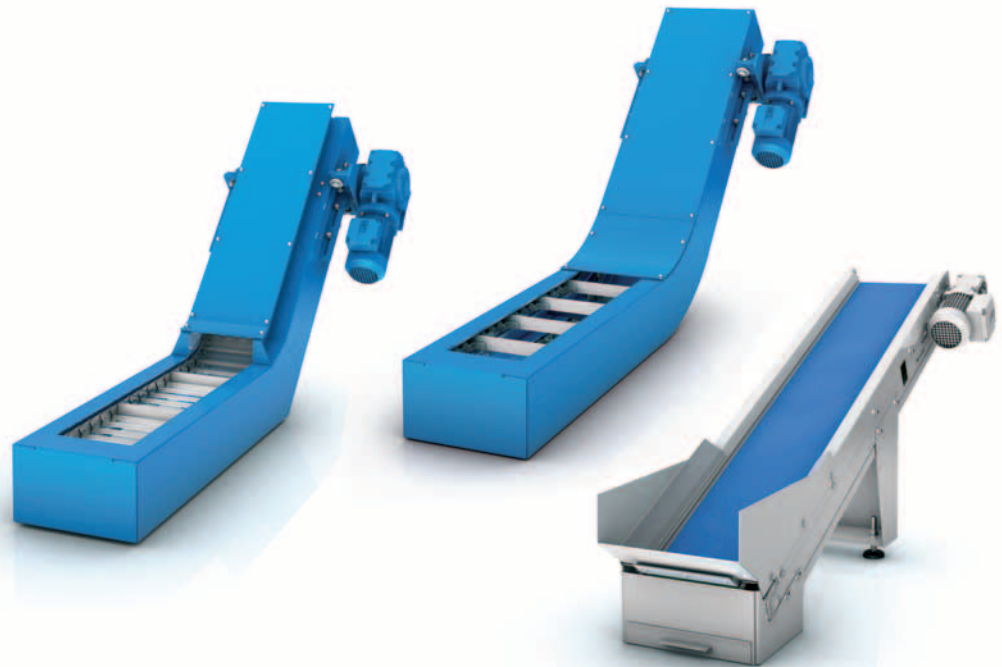

	Page
Hinged belt conveyors	10
Scraper conveyors	16
Belt conveyors	20

Conveyor systems.

Reliability and experience based on tradition.

Our scraper belt, hinged belt and belt conveyors embody more than 30 years of experience. Systematic further development of our products and adaptation of their func-

tions for use with the latest generation of machines guarantees you the utmost level of reliability.

Every production machine requires a disposal system

In the metalworking industry, tonnes of metal chips are created every day at cutting machine tools. We offer the right chip removal system and the suitable conveyor for your specific application.

- For disposal of chips at machine tools
- For transporting metal scrap and chips away from saws
- For disposal at stamping presses and laser cutting systems
- For disposal of edge scrap at trimming shears in coil cutting systems
- For transporting away casting waste in foundry lines



■ Standard hinged belt conveyor at a CNC boring machine

From standard to customized – we have a solution

- Everything from a single source – planning, design and manufacturing
- Standard conveyors available within a short time
- For an individual solution we will work together with you to design a suitable conveyor
- The optimal solution for whatever material is to be conveyed: hinged belt conveyor, scraper conveyor or belt conveyor
- Can be supplied with coolant processing if required
- Quality and long service life are our strong points
- Spare parts supplies are of course ensured for years to come
- Great price-performance ratio

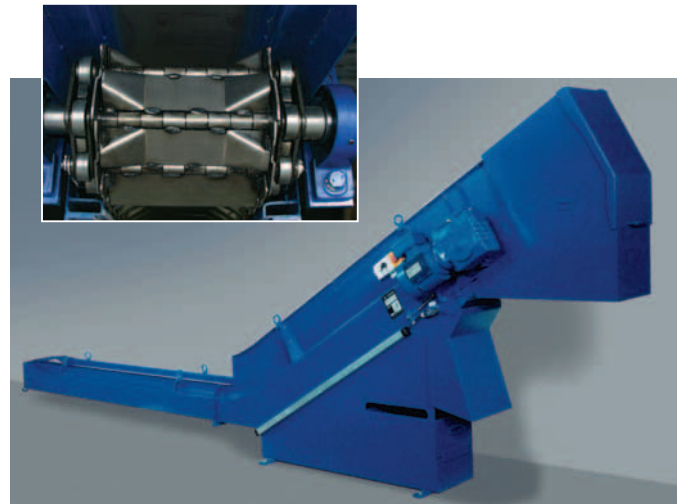

■ Hinged belt conveyor developed for the Trumpf TUBEMATIC laser cutting machine. Special hinged belt plates prevent jamming of the material to be conveyed.

Designs and areas of application

Conveyors are an aspect of mechanical engineering, and are used especially on cutting machine tools. For **many applications** it is possible to use our **standard models**. The material to be conveyed, volume to be conveyed, and space limitations often already determine the type of conveyor.

In most cases, the variable dimensions such as the belt width, feed length, discharge height and incline are sufficient to take the requirements of the specific application in to account.



■ Hinged belt conveyors



■ Scraper belt conveyors



■ Belt conveyors

We also plan and manufacture special conveyors for very specific requirements, even complete chip disposal systems with machine cleaning, crushing, workshop cleaning and hopper storage.



■ Hinged belt conveyor for loading of a hopper system

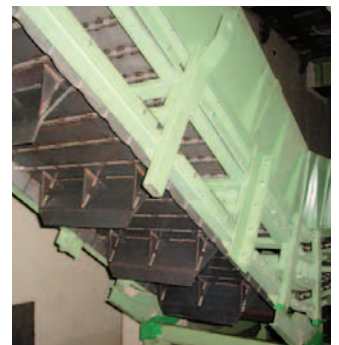

■ Special model at a trimming shear with a belt width of 900 mm



■ Scraper conveyor for distribution of various chip materials



■ Scraper conveyor under a hopper system for aluminium chips

Hinged belt conveyors.

Proven for a wide range of disposal tasks.

Transportation of the material takes place on the upper trough of a revolving hinged belt. Drivers ensure transport of the material up the inclined section.

For wet machining the cooling lubrications are collected in the conveyor housing and can be fed back into the machine circuit via an optionally available coolant container or a pump station.

Our hinged belt conveyors can be used either as stand-alone conveyors at machine tools, or as linked conveyor systems.

Depending on the design, the material to be conveyed is brought to the required height at a defined incline and then discharged.



■ Hinged belt conveyors

This way we can solve your disposal tasks in over 80% of all cases:

- Wet or dry chips
- Workpieces and waste
- Hot forgings
- Stampings and punching scrap
- And much more

Structure

- Stable metal plate construction
- Standardized housing cross-section with variable width
- Robust worm gear motor with torque switching
- Customized discharge height
- Customized incline standards = 30°, 45° and 60°
- Floor mounting or as a push-in version into the machine base

Accessory examples

- Motor monitoring systems with current-monitoring relay
- Other overload safety devices (on request)
- Coolant container with pump station
- Direct electrical connection to your machine controller
- Other special solutions are available. Please do get in touch with us, we will be happy to advise you.

Typical designs

Straight design

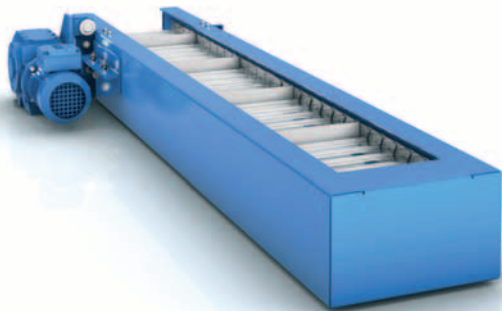

- Can be used in a horizontal or inclined position.
Max incline 45°

Straight/rising design



- Max. incline 45°

Straight/rising/straight design



- Max. incline 60°

Hinged belt conveyors.

Proven for a wide range of disposal tasks.

Types and main areas of application

**SRF 040.00 – the elegant “small one”,
and particularly compact.**

Pitch of the hinged belt $t = 40$ mm

With its small pitch (40 mm) and extremely compact design, this conveyor is suitable for even the smallest machine tools.



**SRF 063.00 – the “classic”,
and our best seller.**

Pitch of the hinged belt $t = 63$ mm

The conveyor type for most mechanical engineering applications.

**SRF 100.00 – the “big one”
and especially robust.**

Pitch of the hinged belt $t = 100$ mm

With a pitch of 100 mm, this conveyor is particularly useful when large quantities of chips are present.



**SRF 150.00 – the “strongest” one
we build.**

Pitch of the hinged belt $t = 150$ mm

Special solutions with 150 mm pitch for transporting away of large outputs or large parts.

Hinged belt designs

Various hinged belt designs are available for different operating conditions:

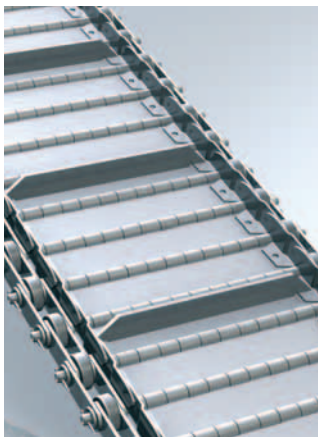

■ **Hinged belt (standard)**
for dry materials and chips with a low proportion of coolant



■ **Hinged belt with perforations**
for pre-separation of coolant for materials with a high proportion of coolant



■ **Hinged belt conveyor with corrugations**
for transporting "sticky" parts

Standard dimensions

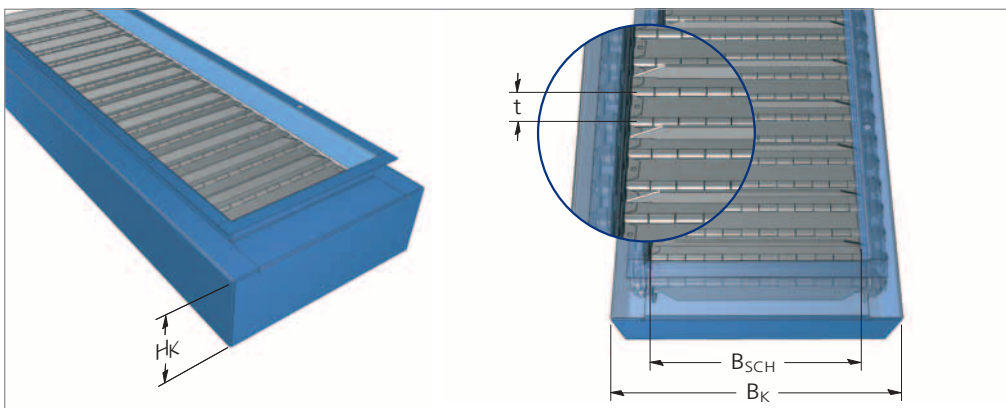

Type	Pitch t	Box height H _K	Hinged belt width B _{SCH}	Box width B _K
SRF 040.00	40	140	150, 200, 250, 300, 450, 600	B _{SCH} + 75 mm
SRF 063.00	63	216	150, 300, 450, 600, 750, 900	B _{SCH} + 120 mm
SRF 100.00	100	360	150, 300, 450, 600, 750, 900	B _{SCH} + 150 mm
SRF 150.00	150	540	300, 450, 600, 750, 900	B _{SCH} + 190 mm

Special widths on request.

Hinged belt conveyors.

Proven for a wide range of disposal tasks.

Dimensions of conveyor housing

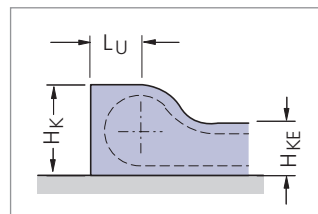
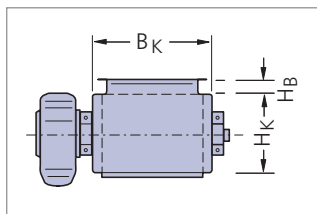
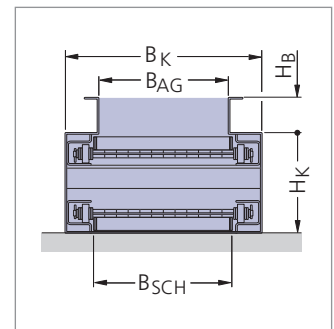
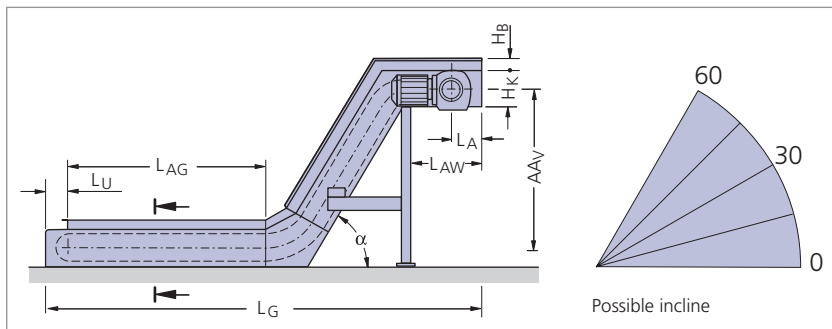

Variable dimensions:

B_{Sch} = Hinged belt width
 B_K = Box width
 B_{AG} = Feed width
 H_B = Panel height

AA_V = Distance between axles, vertical
 L_{AG} = Feed length
 L_{AW} = Discharge length
 L_G = Total length of the conveyor
 α = Incline

Design-dependent dimensions:

H_K = Box height
 H_{KE} = Retracted box height
 L_A = Length of the tail (discharge)
 L_U = Length of the tail (feed)

The tensioning station is located at the discharge.

Dimensions in mm

Type	H_B		H_K	H_{KE}	L_{AW} min	L_A	L_U	
SRF 040.00	40	60	–	140	110	500	180	73
SRF 063.00	40	80	150	216	153	620	240	111
SRF 100.00	150	250	–	360	260	1000	600	185
SRF 150.00	150	250	350	540	390	1000	600	275

The enquiry form can be found on page 70.

Dimensions of hinged belt

Manufactured of strip steel, the hinged belt plates have roller-formed hinge eyes, and are connected by means of axles to the side chains (which are designed as hollow pin chains), thus forming a hinged belt assembly.

Dimensions in mm

Type	t	S _{SCH}	H _s
SRF 040.00	40	1.5	20
SRF 063.00	63	3.0	35
SRF 100.00	100	3.5	60
SRF 150.00	150	5.0	100

Definitions:

- t = Pitch
- B_{Sch} = Hinged belt width
- S_{SCH} = Plate thickness of the conveyor
- H_s = Height of the side rim

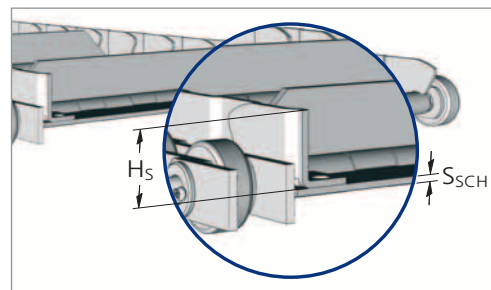
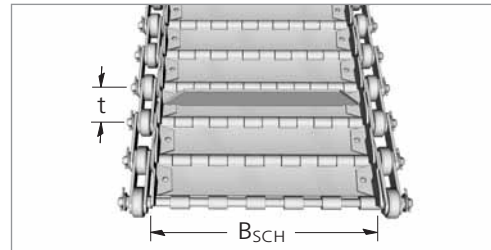

Dimensions as a function of the hinged belt width

Dimensions in mm

Type	B _{SCH}	B _K	B _{AG}
SRF 040.00	150	225	130
	200	275	180
	250	325	230
	300	375	280
	450	525	430
	600	675	580
SRF 063.00	150	270	130
	300	420	280
	450	570	430
	600	720	580
	900	1020	880
SRF 100.00	150	300	120
	300	450	270
	450	600	420
	600	750	570
	900	1050	870
SRF 150.00	300	490	250
	450	640	400
	600	790	550
	750	940	700
	900	1090	850

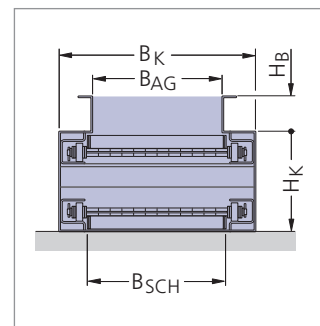

Definitions:

- B_{SCH} = Hinged belt width
- B_K = Box width
- B_{AG} = Feed width

Scraper conveyors.

For disposal of small materials.

Transport of the material takes place via drivers which push the material along the floor of the housing towards the discharge.

Cooling lubricants are collected in the conveyor housing and can be fed back into the machine circuit via an added-on container or a pumping unit.

Our scraper conveyors can be used as stand-alone conveyors at machine tools or as linked conveyor systems.

Depending on the design, the material to be conveyed is brought to the required height at a defined incline and then discharged.

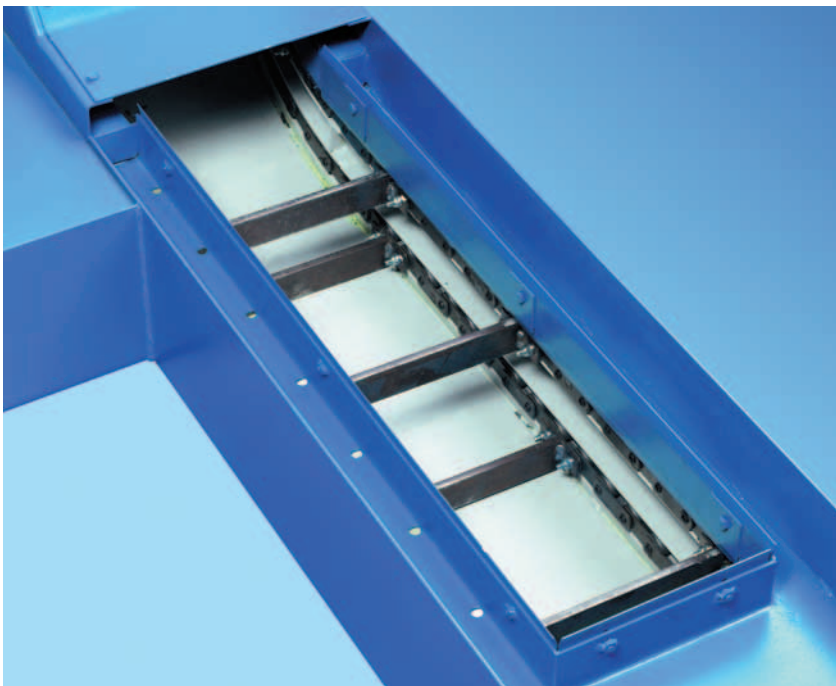

■ Scraper belt conveyors

The solution for small and short chips:

- Frequently used for machining of non-ferrous metals
- Can also be used for very hard, short chips
- Casting chips, milling chips and sawing chips

Structure

- Stable metal plate construction
- Standardized housing cross-section with variable width
- Robust worm gear motor with torque switching
- Customized discharge height
- Customized incline standards = 30°, 45° and 60°
- Floor mounting or as a push-in version into the machine base

Accessory examples

- Motor monitoring systems with current monitoring relay
- Other overload safety devices (on request)
- Coolant container with pump station
- Direct electrical connection to your machine controller
- Other special solutions are available. Please do get in touch with us, we will be happy to advise you.

Typical designs

Straight design

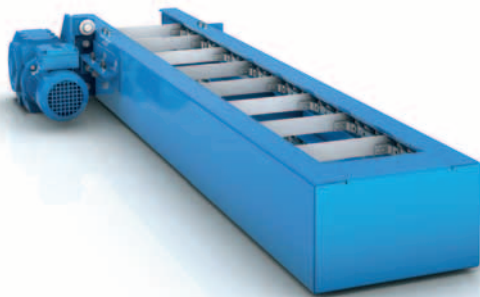

- Can be used in a horizontal or inclined position.
Max incline 45°

Straight/rising design



- Max. incline 45°

Straight/rising/straight design



- Max. incline 60°

Scraper conveyors.

For disposal of small materials.

Types and main areas of application

KRF 040 – the “classic” scraper conveyor

Pitch of the scraper belt $t = 40$ mm

Our standard scraper conveyor for smaller machine tools and small quantities of chips.



KRF 063 – for somewhat “bigger” tasks

Pitch of the scraper belt $t = 63$ mm

For larger machines and larger quantities of chips.



KRF 100 – the “strongest” one we build.

Pitch of the scraper belt $t = 100$ mm

Special solution for very large quantities of chips



Standard dimensions

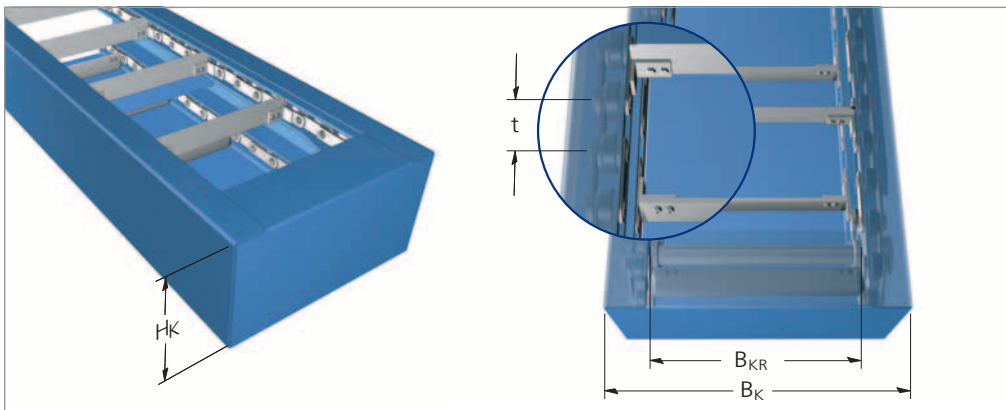

Type	Pitch t	Box height H _K	Scraper belt width B _{KR}	Box width B _K
KRF 040.00	40	140	150, 200, 250, 300, 450, 600	B _{KR} + 90 mm
KRF 063.00	63	216	150, 300, 450, 600, 750, 900	B _{KR} + 110 mm
KRF 100.00	100	360	150, 300, 450, 600, 750, 900	B _{KR} + 165 mm

Special dimensions on request.

Dimensions of conveyor housing

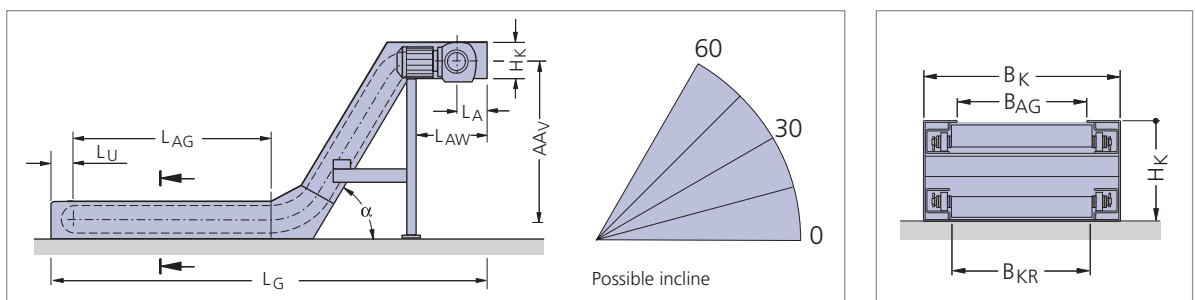

Dimensions in mm

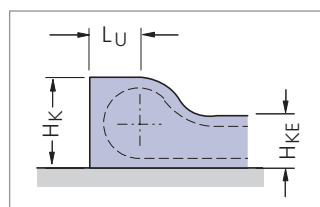
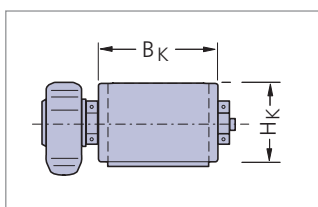

Type	H _K	H _{KE}	L _{AW}	L _A	L _U min
KRF 040.00	140	110	500	180	73
KRF 063.00	216	153	620	240	111
KRF 100.00	360	260	1000	600	185

Variable dimensions:

- B_{KR} = Scraper width
- B_K = Box width
- B_{AG} = Feed width

- AA_y = Distance between axles, vertical
- L_{AG} = Feed length
- L_{AW} = Discharge length
- L_G = Total length of the conveyor
- α = Incline

Design-dependent dimensions:

- H_K = Box height
- H_{KE} = Retracted box height
- L_A = Length of the tail (discharge, incl. tensioning distance)
- L_U = Length of the tail (feed)

The enquiry form can be found on page 72.

Belt conveyors.

The all-rounders – also for parts with sharp edges.

Our belt conveyors are predominantly used on punch-nibbling machines, for transporting punching scrap and punching trimmings.

However, other parts can also be transported, such as waste parts from plastic injection machines. The transport belt of the conveyor is resistant to oil and grease.



■ Belt conveyors

Structure

- Housing made of steel plate
- Oil-resistant belt
- Protective motor switch
- Convex return shafts
- Shafts with ball bearings
- Adjustable belt tension

The universal transport solution, for applications where no cooling lubricant is present.

- Also suitable for parts with sharp edges
- Not suitable for transporting hot chips

Standard design

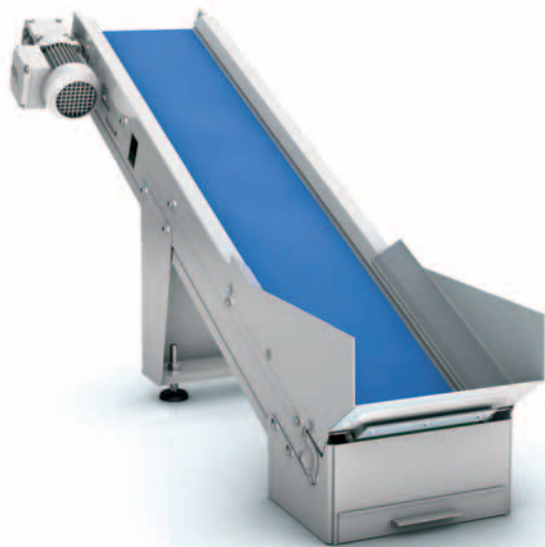

■ **Standard design**

Can be used in a horizontal or inclined position.
Max incline 30°

Standard dimensions

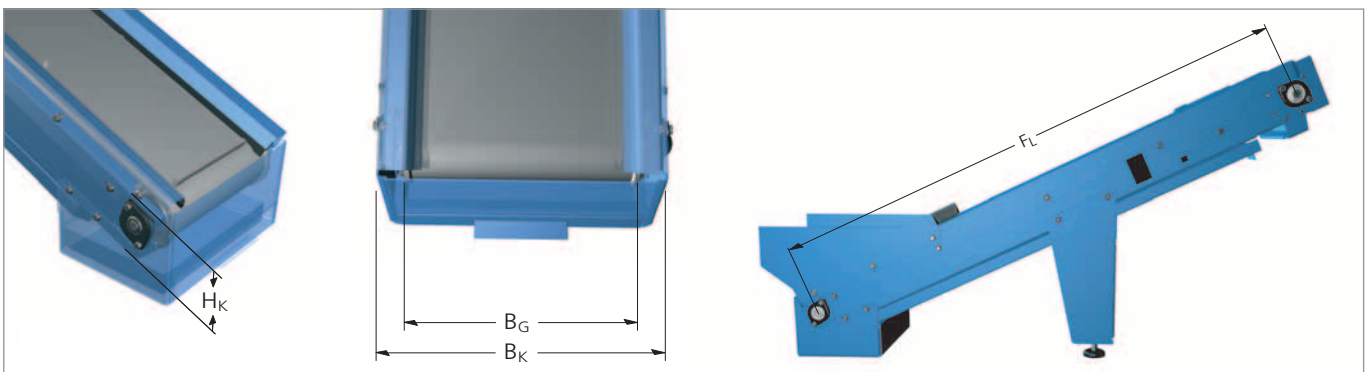

Dimensions in mm

Type	Box height H_K	Belt width B_G	Box width B_K	Maximum conveying length F_L
GBF 040.00	104	150, 200, 250, 300, 450, 600	$B_G + 50$	5000

Special widths on request.

The enquiry form can be found on page 74.

Subject to change.



Guideway protection systems.

Perfect protection for guideways on machine tools.

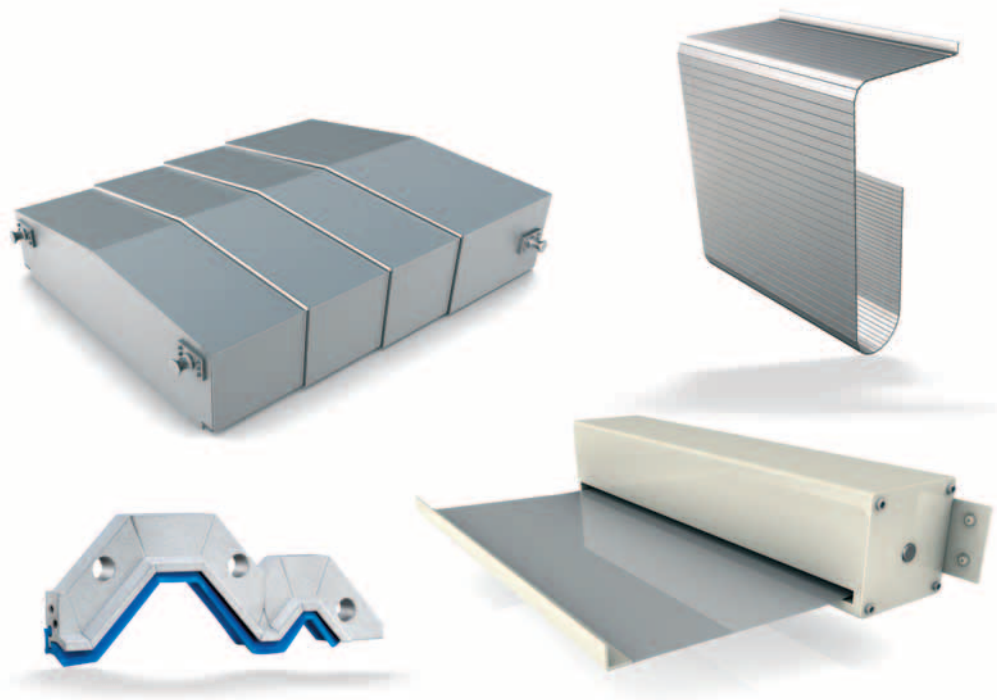

	Page
Telescopic covers	24
Way wipers	40
Link apron covers	49
Bellows	53
Conical spring covers	55
Conveyor belt covers	58

Telescopic covers.

Perfect protection for guideways on machine tools.

Wherever guideways on machines have to be protected, we have a suitable solution. Our guideway protection systems boast a high

degree of operational reliability, a long service life, and make use of innovative technical solutions.

Every production machine requires protection for its guideway

Today, modern machine tools process workpieces at ever-greater cutting and travel speeds. The protection of guideways, measuring systems, drive elements and other vulnerable parts is absolutely essential. Accelerations and speeds of machines are constantly increasing.

Telescopic covers must also be able to cope with these challenges. This is where telescopic covers with harness mechanisms are used.

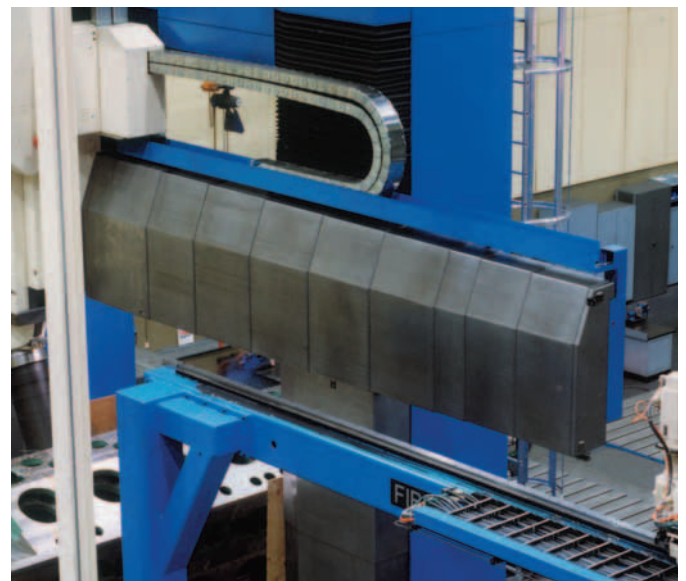

■ Cross-beam cover at a milling machine

From individual manufacture to series production – we have a solution

The number of varieties is immense, no cover for a machine is exactly the same as any other.

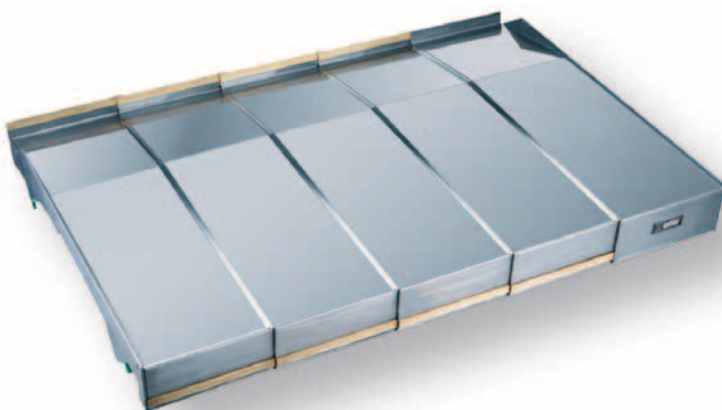

■ Series cover

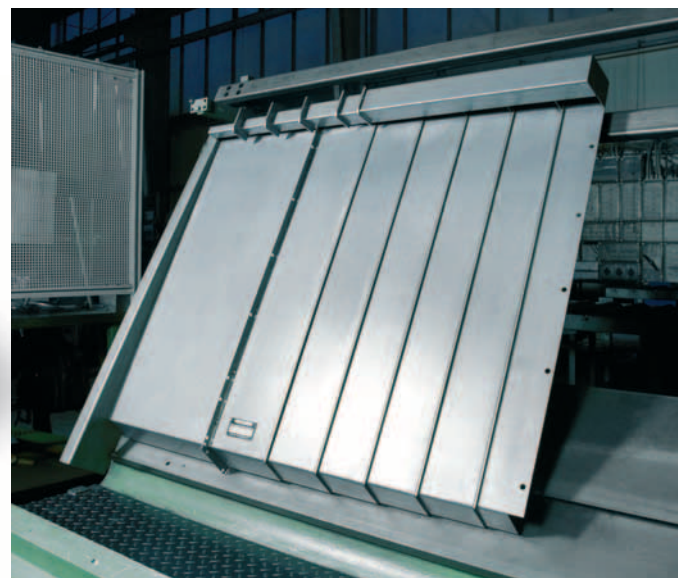

■ Special form of an inclined bed cover on a test framework

Designs and areas of application

Until the 1970s, telescopic covers seldom moved in speed ranges any greater than 15 m/min.

The expansion and compression of the individual boxes took place sequentially. Due to the low speed, there was hardly any impact noise.

Over the years, however, improvements in drive technology have increased the travel speeds of the machines and thus also the speeds of the cover.

At high travel speeds, the impact pulse exerted on the cover becomes truly enormous. This results in loud impact noises. What is more, the telescopic cover is subjected to very large mechanical stresses.

The landscape for telescopic covers has changed greatly in the last few years.

“Old” designs are less and less in demand, with modern concepts such as covers with differential drives taking their place.



■ Telescopic cover with flat shape on a boring machine

Telescopic covers are generally produced from cold-rolled uncoated thin plates in thicknesses from 1 to 3 mm.

In case of extremely aggressive environmental conditions (e.g. aggressive cooling lubricants), corrosion-resistant stainless steel plates may also be used.

The new generation of KABELSCHLEPP telescopic covers also allows the use of semi-finished products with surface finishings such as:

- Plates with pure zinc coatings
- Plates with zinc/nickel coatings
- Plates with lead/zinc coatings

This ensures substantial protection against corrosion.

Telescopic covers.

The speed is decisive.

At speeds below 15 m/min a telescopic cover can still be built in the conventional form of box synchronization. At higher speeds, however, the inevitable impact noises become clearly audible and unpleasant.

So-called differential drives serve to synchronize the boxes and eliminate the impact noises. KABELSCHLEPP has chosen the old, proven harness mechanism principle, in which special materials are used.

Telescopic cover with damping elements

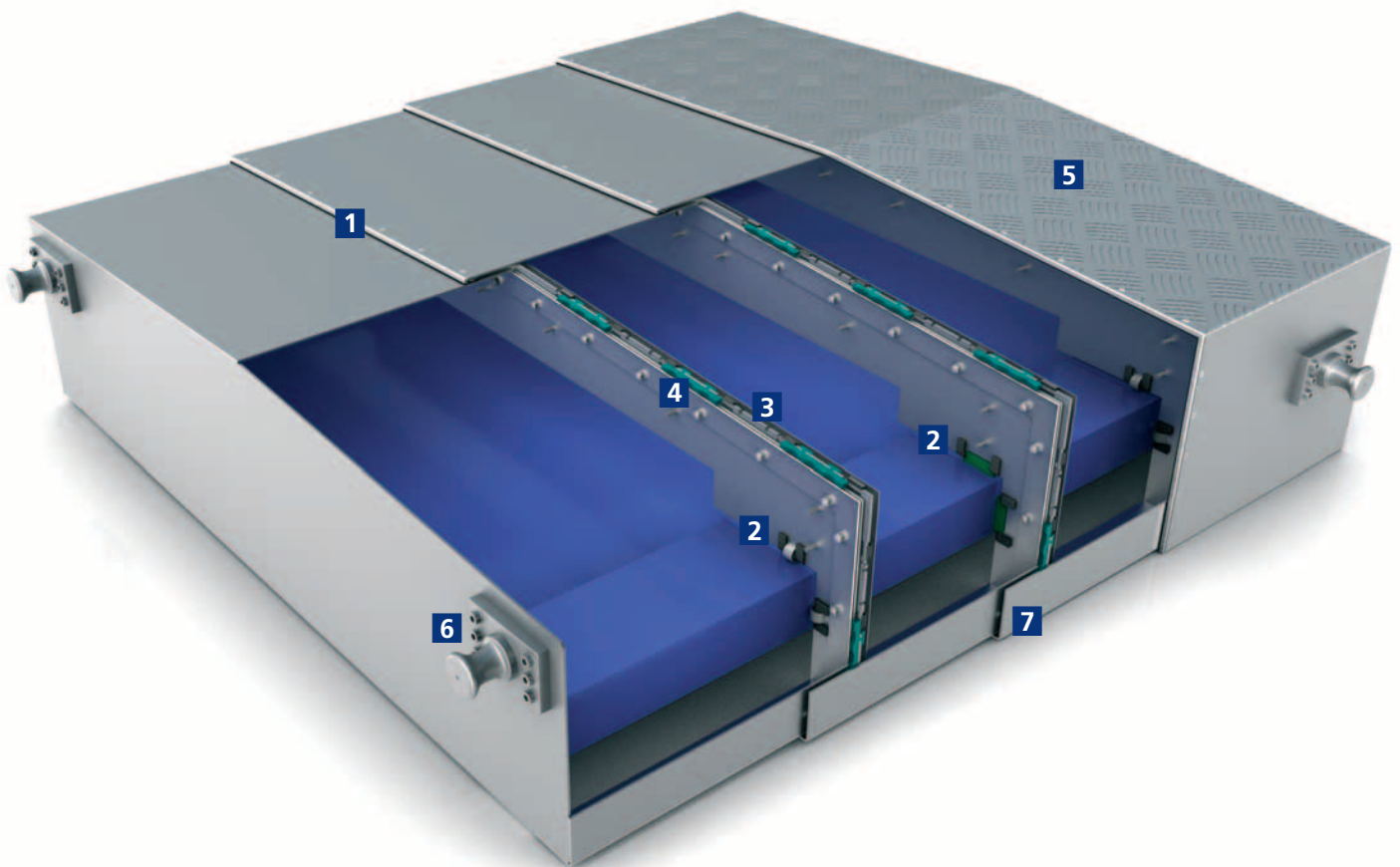

- 1** Wiper systems in various designs
- 2** Rollers / sliders
- 3** Gully in various designs
- 4** Damping systems in various designs

- 5** Structural metal plates to prevent slipping (on the largest box)
- 6** Lifting element
- 7** Locking system

Travel speed	Damper elements / harnesses
Up to 15 m/min	Not required
Up to 30 m/min	Damper elements
Up to 60 m/min	Damper elements / harnesses

The use of damping elements depends on the travel speed and the moving mass. The information in the table should therefore only be viewed as guide values.

Telescopic cover with harness mechanism

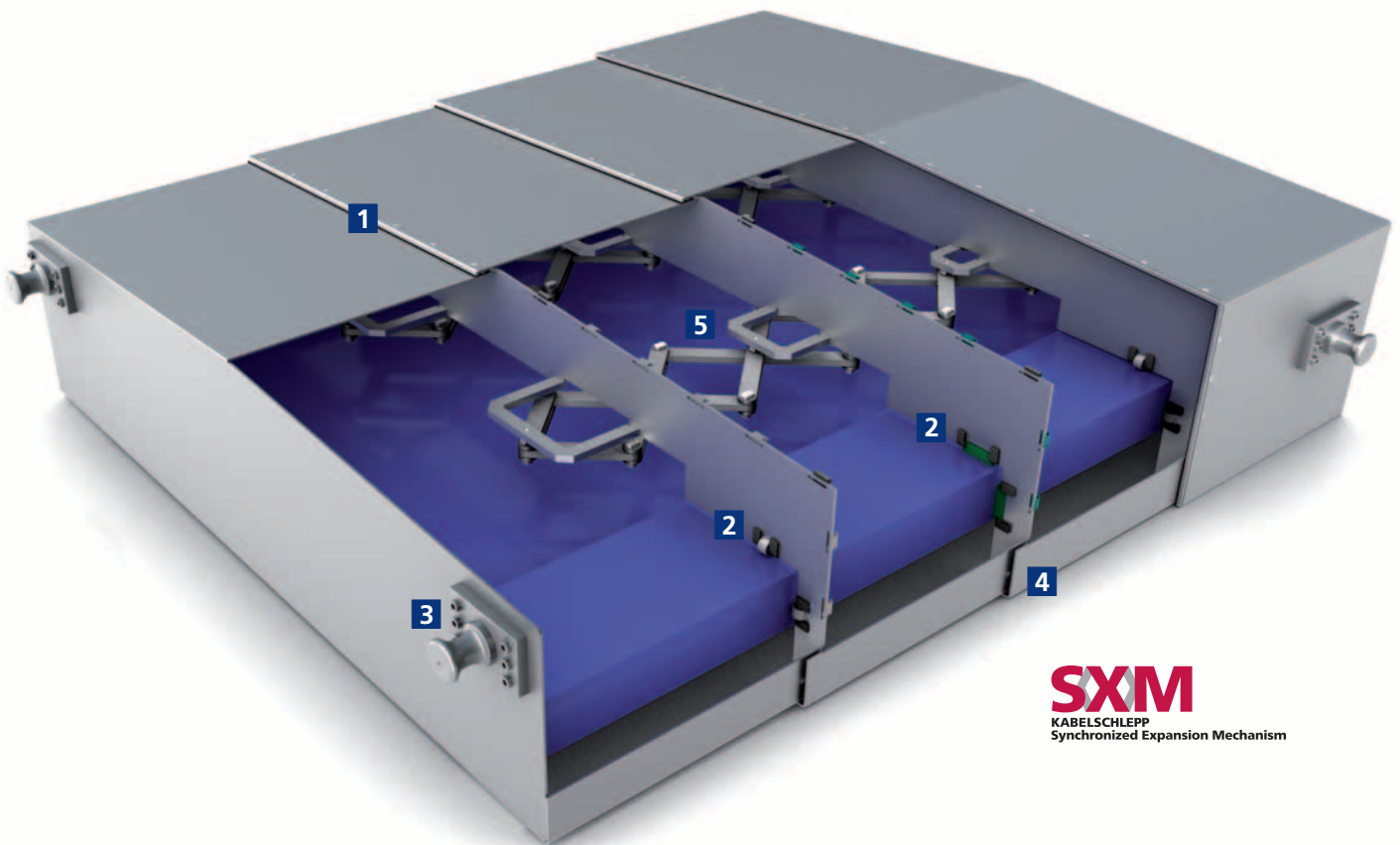

SXM
KABELSCHLEPP
Synchronized Expansion Mechanism

- 1** Wiper systems in various designs
- 2** Rollers / sliders
- 3** Lifting element

- 4** Locking system
- 5** Synchronising device (harnesses) for fast-running telescopic covers

SXM – Mechanical elements with harnesses.

KABELSCHLEPP sets the mark.

To ensure impact-free expansion / compression of telescopic covers, they are used with so-called synchronisers (harnesses). As a result, all of the cover boxes move

evenly during expansion and compression. The individual boxes move relative to each other only at a differential speed.

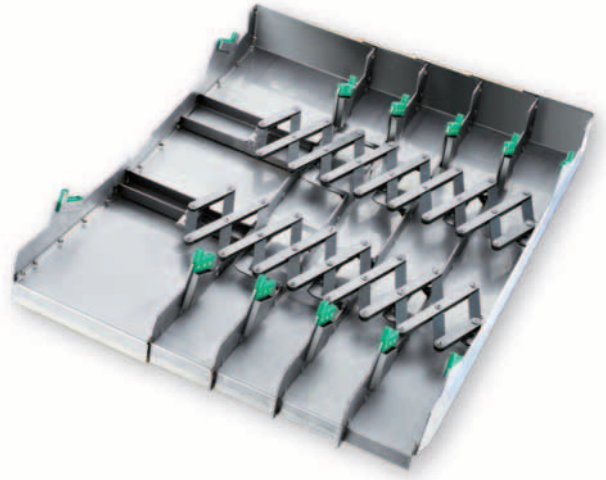
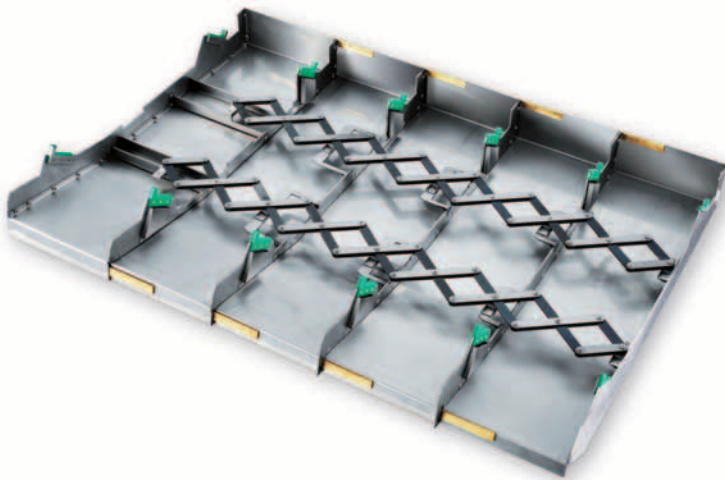

- Telescopic cover with proven harness mechanism in various expansion states.

SXM

KABELSCHLEPP
Synchronized Expansion Mechanism

SXM – Synchronized Expansion Mechanism.

The KABELSCHLEPP harness technology is used wherever you find this symbol.

Telescopic covers with harness mechanisms have many advantages:

- High travel speeds up to 200 m/min are possible.
- **Acceleration forces** and speeds are **uniformly distributed across all the plates**. This also applies to the resultant inertial forces.
- The **force peaks** that would normally occur when the telescopic covers dashed against each other **do not occur**.
- The disruptive **impact noise** of the boxes **is eliminated**.

Cover with two harnesses

This solution has been developed for travel speeds greater than 100 m/min. Two harnesses ensure synchronization. In the example shown here the cover plates are made of 1 mm thick stainless steel.

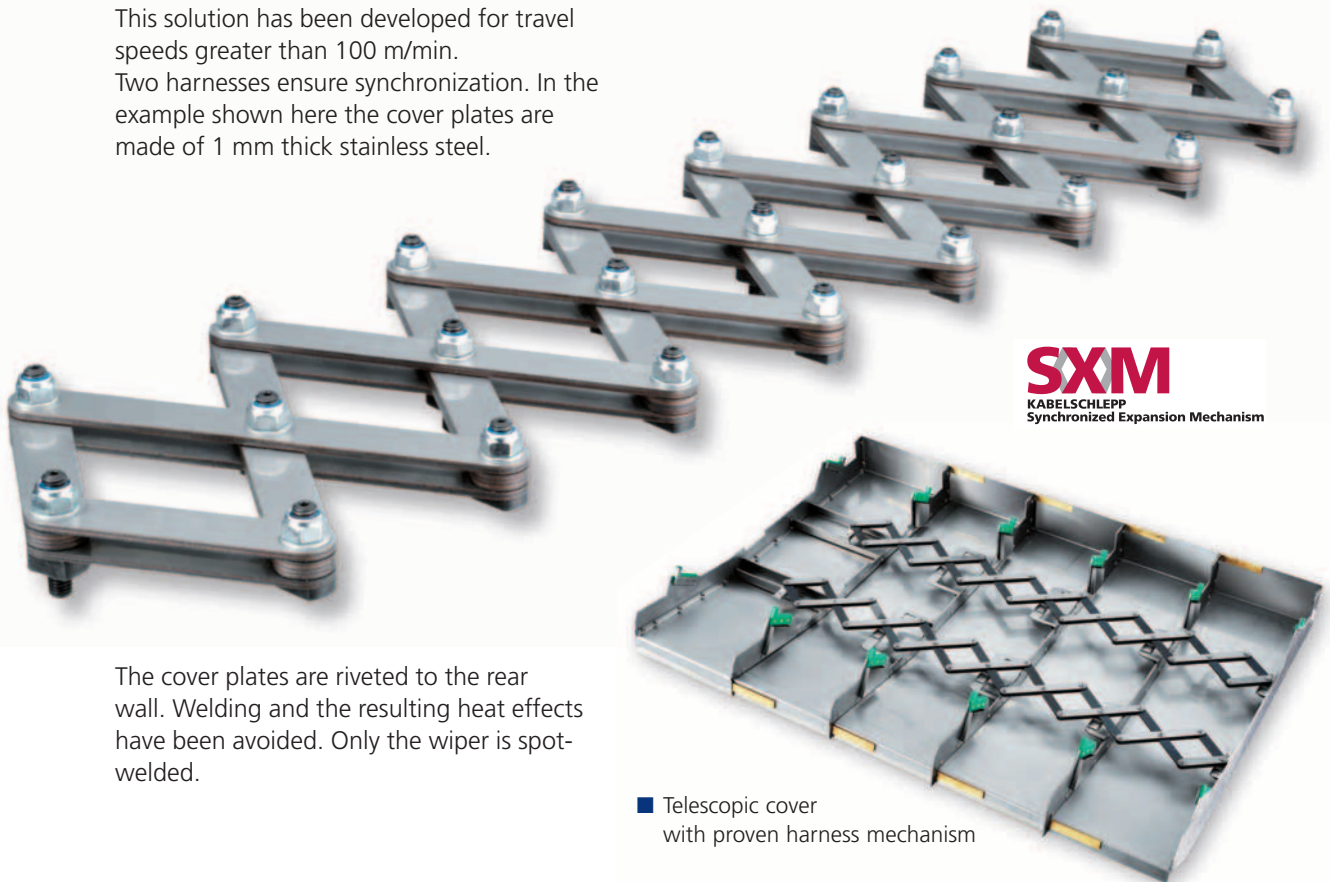

The cover plates are riveted to the rear wall. Welding and the resulting heat effects have been avoided. Only the wiper is spot-welded.

■ Telescopic cover with proven harness mechanism

Cover with one harness

This particularly lightweight solution has been developed for "small" machine tools. The cover plates are made of 1 mm thick normal steel.

The travel speed in this special application is only 30 m/min. The harness mechanism serves to ensure synchronization, however, and the reduced mass of all the elements means that it was possible to develop an especially cost-effective solution here.

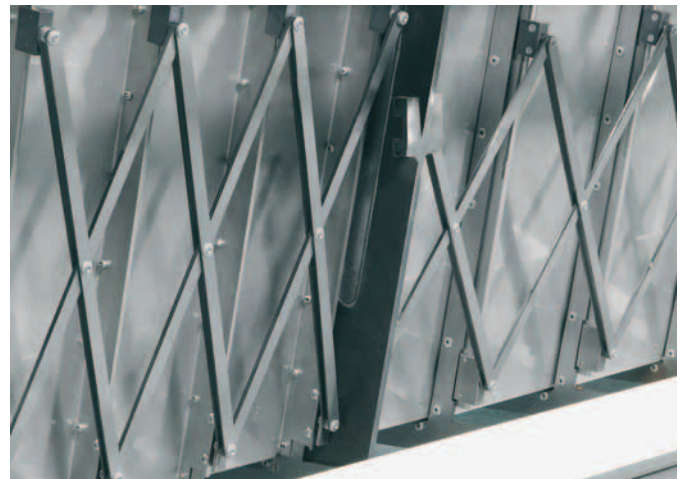

■ Telescopic cover with only one harness

Telescopic covers.

Perfect protection for guideways on machine tools.



Photograph: Waldrich Siegen Werkzeugmaschinen GmbH

Designs

Machine tools come in a wide variety of designs. That is why a modern lathe needs another type of telescopic cover than, for

example, a large bed-type milling machine. The following designs provide an overview of typical designs.

Flat shape

The U-shaped design is generally used in a horizontal, lying position for milling table guides. With this design the maximum width of the telescopic cover should be limited to 1.5 m.



Roof shape, centric (eccentric)

This design is always advisable when cooling lubricants are used. The inclined surface allows the water – and naturally also the chips – to run off more easily. With large covers (> 3 m width) for reasons of stability, etc. at least three roof angles should be provided.



Flattened roof shape

The flattened roof shape is a special construction method with two roof angles. Primarily for dry operation and widths > 3 m.



Shape with incline to one side

The shape with incline to one side has a special roof shape. Depending on the possible incline, covers can be constructed with widths of up to 1.5 m. This shape is likewise a recommended solution when large amounts of coolant are present. Depending on the angle of incline, this form also helps to discharge coolants / chips.



Vertically-installed telescopic cover

Standing covers are used on larger machine tools, mostly in the area above and below the cross beam. They can take many different shapes.



Blind cover

With blind telescopic covers, the cover plates move in separate guide rails, each of which is mounted on the machine at the sides. It is used exclusively in a vertical arrangement. The guide rails are generally made of brass.



Cross-beam cover

These covers are predominantly used on large gantry machine tools on a cross beam to the left and right of the support. The boxes are suspended vertically and protect the support guides from chips and cooling lubricants.



Tubular cover, polygonal cover

Tubular covers or covering shafts, spindles, etc. They can be made either with a round or a polygonal shape.

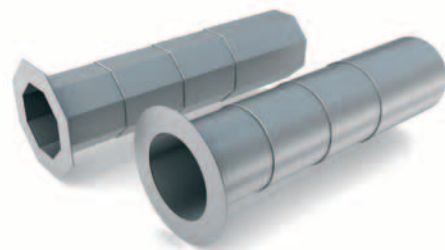

The enquiry form and the design dimensions can be found on page 75ff.

Other forms and special designs tailored to your specific requirements are possible. Please do get in touch with us, we will be happy to advise you!

Wipers on telescopic covers.

Wipers on telescopic covers keep the cover boxes clean and prevent the penetration of dirt and chips.

Welded-on and riveted-on wipers

With these types the support profile is spot-welded or riveted to the cover box.

Type MA 8 / MA 12

These wipers consist of an NBR profile vulcanized onto a steel strip.

Necessary calculated distance of the cover plates 2.5 to 3.5 mm.

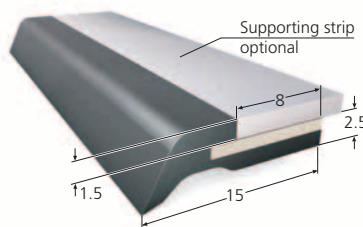

■ Wiper type MA 8

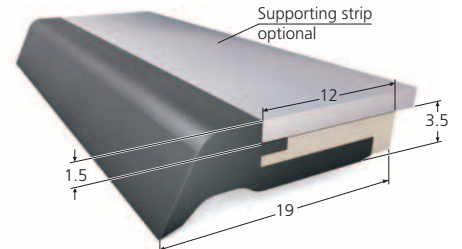

■ Wiper type MA 12

Type MA 8S / MA 12S

Wipers MA 8 and MA 12 are covered with a protective strip for protection against hot chips.

Necessary calculated distance of the cover plates 3.5 to 4 mm.

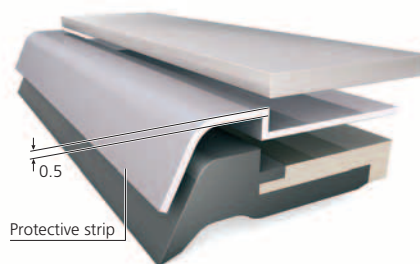

■ Wiper type MA -S

Type MA 12.1 / MA 18

A specially-milled steel plate profile is spot-welded to the boxes and a PUR wiper lip is inserted.

Necessary calculated distance of the cover plates 3.5 to 5.5 mm.

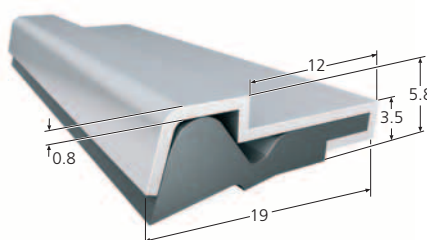

■ Wiper type MA 12.1

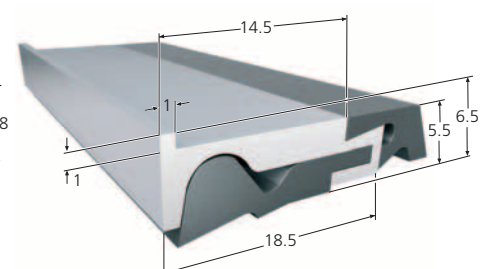

■ Wiper type MA 18

Welded-on and riveted-on wipers

Steel plate wiper made of spring band steel

A specially shaped, approximately 0.4 mm thick, approximately 25 mm wide band of stainless spring band steel is spot-welded to the cover plate. This wiper is recommended for dry machining.

Necessary calculated distance of the cover plates 1 mm.

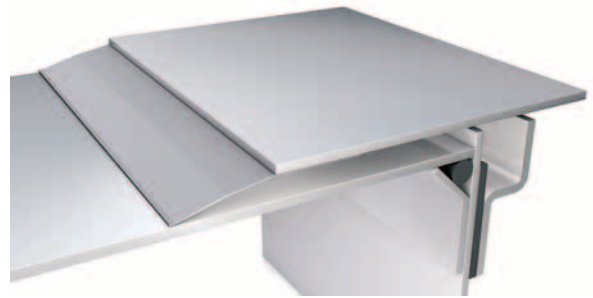

Types with replaceable wiper lips – the new generation

The replaceable wiper with a PU lip

This new generation of wipers can be replaced directly on the machine, without disassembling the telescopic cover.

The wiper consists of four parts: a retaining section of steel, a wiper lip of PU, a spring profile of plastic and a fastening pin.

By rotating the fastening pin through 90°, the wiper system is fastened to the cover plate, or loosened from it. The spring profile generates a defined pressure.

Necessary calculated distance of the cover plates 5 to 5.5 mm.

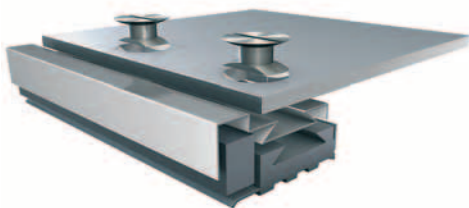

The replaceable wiper made of steel

Here a solution has been developed that makes the above-mentioned spring band steel wipers replaceable. A specially-shaped support plate is spot-welded to the box. The wiper can then be pushed in. The spring force of the support plate holds the wiper in place. The holding forces are increased by defined fixing points.

Necessary calculated distance of the cover plates 1 mm.

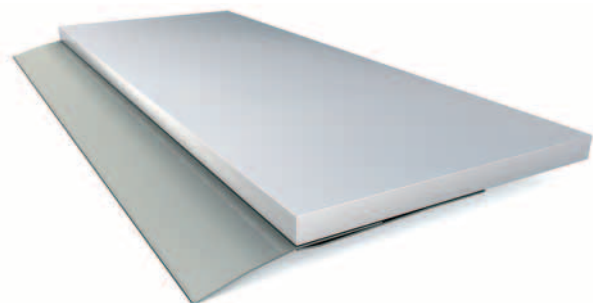

Damping elements on telescopic covers.

Telescopic covers with travel speeds greater than 15 m/min must be provided with dampers in order to reduce impact noises.

Wiper type MA 18 with damping

The support profile is made of aluminium and is screwed or riveted on. The wiper lip is identical to MA 12.1. The special damping profile can be installed in the rear aperture formed onto the support profile.

Necessary calculated distance of the cover plates 5.5 mm.



Brass strips with damping

Brass strips are used primarily on standing covers. The damping profile described above can likewise be mounted on an appropriately drawn brass profile.

Necessary calculated distance of the cover plates 5.5 mm.



Vibration absorber

To damp impact noise effectively, vibration absorbers can be fitted in the rear walls of the covers. Depending on the individual situation and travel speed, the number of dampers is varied in order to achieve an optimum result.

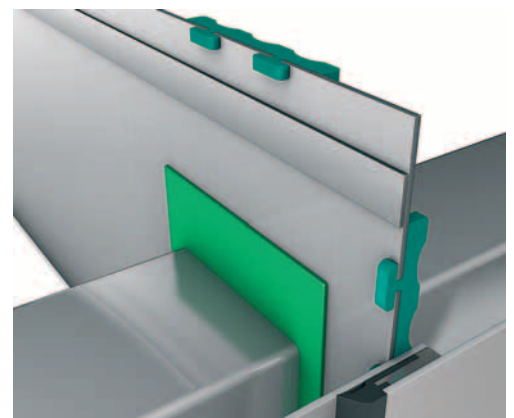

Damping elements for compression

Damping elements that only work during expansion require an additional element for compression. Here simple rubber buffers mounted at an appropriate point on the rear wall have proven themselves over many years.



Splash- and hose-proof protection on telescopic covers.

Over time cooling emulsion and fine chips can be “pumped” under the individual boxes and make it over the rear wall into the machinery space that is being protected. In many cases this is undesirable.

Machine tools with hydrostatic bearings require “watertight” covers.

Gullies for telescopic covers

In order to catch coolant and chips that make it over the rear wall, a gully is generally installed on the back of the rear wall. This gully allows the fluids to be drained off to the sides.

Aluminium gully type AL 19

This gully is an extruded aluminium profile which is screwed onto the rear walls of the cover.

The cover plate is bent downwards so that it projects into the gully. This allows the coolant between the plates to flow into the moulded gully.

Condensation water that forms under the cover plates is wiped off by a lip and drained into gullies to the front and back. This makes it possible to achieve a very high level of waterproofing.



Gully type ST 05

This gully is screwed onto the rear wall. This has the advantage of, among other things, meaning that galvanized metal plates can be used (no welding necessary).



The enquiry form can be found on page 75.

Rollers and sliders on telescopic covers.

The individual boxes of telescopic covers are supported by rollers or sliders on the guideways or corresponding supplementary guides. In addition, there are various solutions depending on the qualities of the way:

Plastic rollers

- Gentle rolling on the guideway
- For low travel speeds

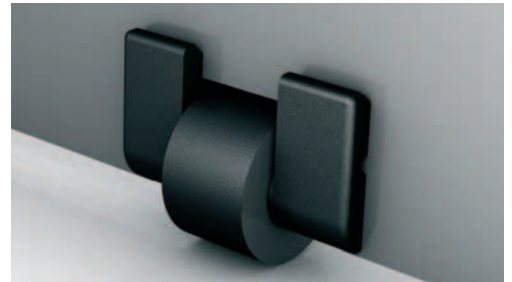

Steel rollers

- For high support loads
- For high travel speeds



Plastic sliders

- Good sliding characteristics on the guideway
- For high travel speeds
- Can also be used for linear guides

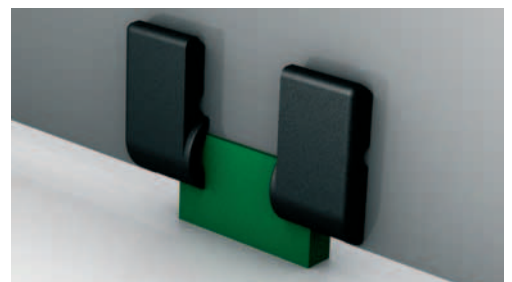

Metal sliders

- For high support loads
- For low travel speeds

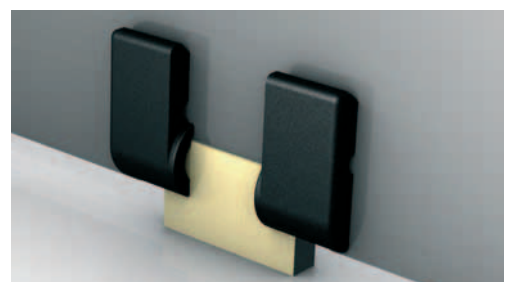

Telescopic covers – the new generation.

New developments from KABELSCHLEPP.

DUPLEX, the vertically traversing cover

These covers are used to separate two machining cells of a machining center.

Thus, a tool change can be carried out in one machining cell, while work continues in the other one.

The partitioning of these two machining cells has to be nearly “bulletproof”, because there are several persons working in one of them, who would be in grave danger without protection.

The vertically traversing telescopic cover DUPLEX is guided by two inside harness mechanisms.

Owing to the double-construction, a high degree of puncture-proofness is achieved, which more than satisfies the requirements. Of course, this construction principle can also be employed for “normal” covering tasks.

Since the covering elements are simply suspended on the harness, very inexpensive solutions are obtained.



SXM
KABELSCHLEPP
Synchronized Expansion Mechanism

■ DUPLEX cover

Telescopic covers – the new generation.

New developments from KABELSCHLEPP.

CROSS-COVER, the ready-to-install solution

Today machining spindles of horizontal drilling machines move in the vertical and horizontal direction with accelerations in the 2 g range and high speeds.

Cover elements for the transverse motion are always in a vertically standing arrangement and move laterally, cover elements for the vertical motion of the spindle move upwards and downwards, and all of their lamellas are arranged horizontally.

Today the machinery space is often protected with bellows, whose fabric structure is often protected against flying chips by means of supplementary lamellas made of stainless steel.

KABELSCHLEPP has developed the turnkey system CROSS-COVER.

The entire machinery space covering is supplied as a pre-finished unit.

The CROSS-COVER is constructed of slim, light plates, which move evenly thanks to integrated harness mechanisms. This eliminates disruptive impact noise, minimises wear and increases service life significantly. The vertically moving plates are preferably made of very hard stainless spring band steel with an integrated wiper.

Due to the greater lengths of the plates, the side covers are made, for example, of 1 mm steel, and the wiper is generally mounted separately.

The construction with harnesses is superior to “normal” covers and other protective systems such as bellows with regard to durability and stability. This pays for itself in the long run, since there is virtually no wear (tested so far: 300,000 motion cycles). At the same time, the weight has been kept low, and ball bearing guide rails ensure smooth, low-friction operation.



■ Ready-to-install CROSS-COVER cover

With CROSS-COVER you save valuable time

We ship the **entire cover unit** to you **ready for mounting** – you can completely cover the spindle side with just a few installation steps. Installation is aided by a frame running around the machine. We design this frame according to your specifications, and ship it to you together with all of the necessary fastening elements.

SXM
KABELSCHLEPP
Synchronized Expansion Mechanism

IN-LINE-COVER, the alternative to bellows and link apron covers

Wherever up until now bellows or link apron cover solutions have been used to prevent entry of chips, now there is a slim, robust, cost-effective alternative.

KABELSCHLEPP IN-LINE-COVERS offer the resistance capacity of telescopic covers with less weight and lower costs.

For example, you can use IN-LINE-COVERS as a cross-beam cover on gantry machine tools to protect their vulnerable drive systems against particles and fluids. Or as an alternative to link apron covers when machine components have to move in one dimension.

With the IN-LINE-COVER, the harness mechanisms provide more even motion and very smooth operation.

Here, too, the KABELSCHLEPP SXM harness principle prevents force peaks and excessive noise generation. A construction method which has proven itself thousands of times over.

New, on the other hand, is the suspension of the plates at the central pivot point of two harnesses and guidance of the harness points on one or two guide rails.

This design saves weight, and at the same time increases stability and allows narrow lamellas. It also reduces weight significantly compared to a telescopic cover.



■ IN-LINE-COVER
with harness mechanism

SXM
KABELSCHLEPP
Synchronized Expansion Mechanism



The individual plates of the cover are made of 0.5 -1.5 mm thick spring band steel, normal steel or stainless steel, depending on the length of the specific element:

- very light (reduced weight)
- Corrosion-resistant when stainless steel is used
- Long service life

Way wipers.

The cleanup crew on guideways.

Way wipers are essential to keep the guideways in a proper functional state, and thus to keep the machine tool permanently in operation.

Even if the guideways are already protected by a telescopic cover, it is necessary to wipe fine, penetrating particles off of the vulnerable ways.

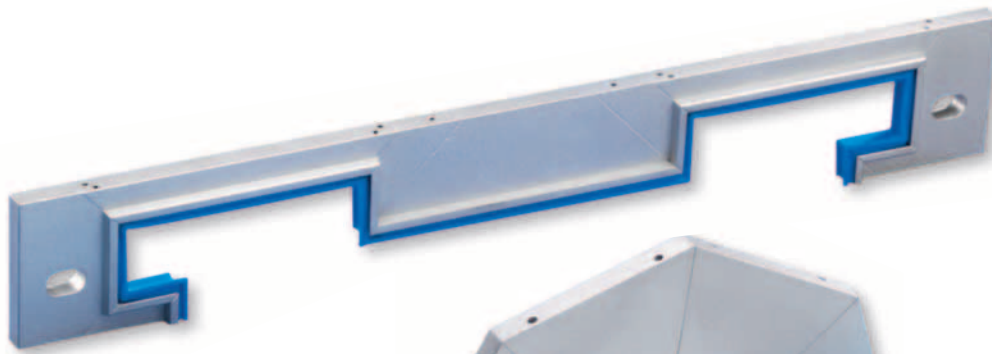

■ Harnessed way wipers

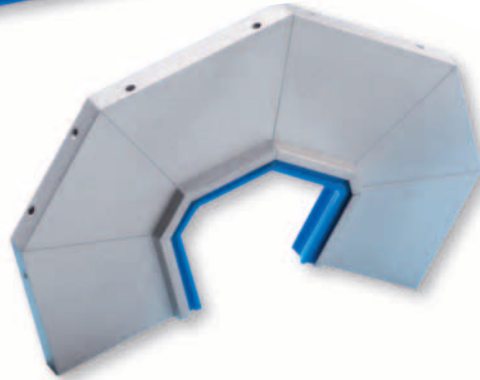

■ Cast wiper with steel support strip



■ Way wipers in a modular system

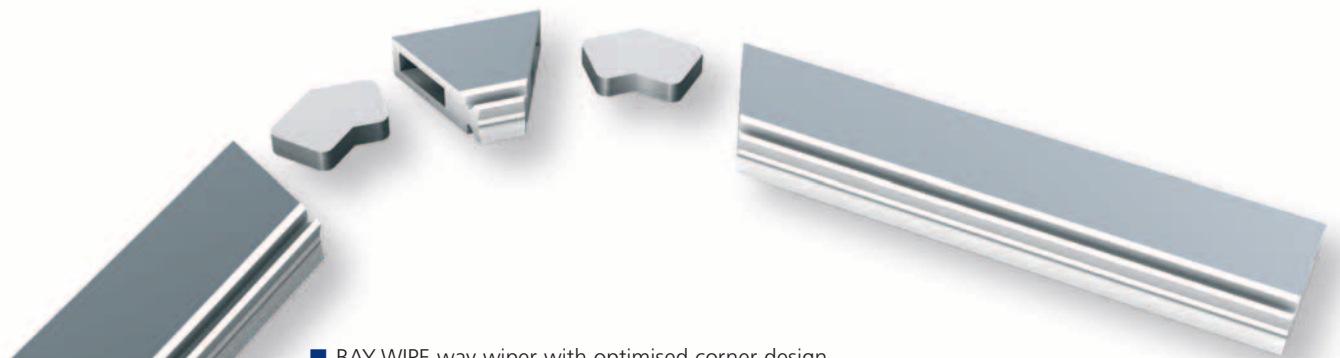

■ BAY-WIPE way wiper with optimised corner design.

Overview and delivery forms

Harnessed way wipers – proven in millions of applications

Available in a wide variety of shapes,
harnessed according to your specifications,
in bar form or available ex-stock.



Way wiper BA 65

Cast wiper with steel support strip,
available ex-stock in bar form.



Way wiper BA 115 – with extra-long lip

Highly-flexible cast wiper with steel support
strip, available ex-stock in bar form.



Way wipers in a modular system – the clever solution

The most economical alternative to cast
wipers.



Way wiper types BA and BAS.

Wipers of this type have a replaceable lip and guarantee high form stability and mechanical loading capacity. They are manufactured in custom forms according to your specifications.

Available as bar material ex-stock.

Note: Reduce costs

With types BA and BAS the wiper lip is replaceable. In case of wear, only the lip has to be exchanged; the support profile can remain in use.

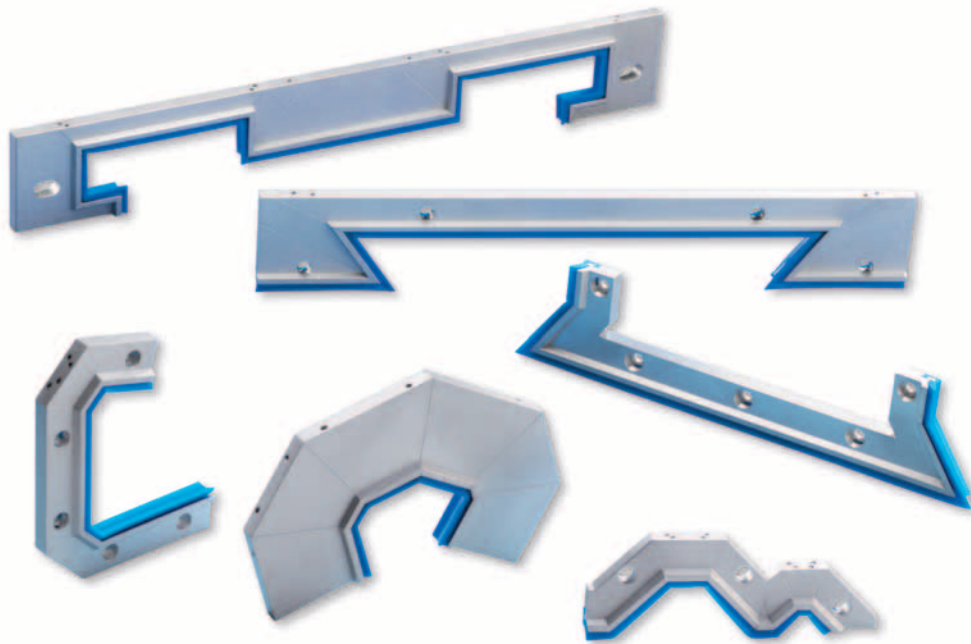

Properties

- Temperature range -40 °C to 100 °C
- Support material: Aluminium
- Wiper lip material: Polyurethane
- Largely resistant to oils, greases, alkalis and water
- Pretension approx. 2 mm
- Replaceable wiper lip
- Standard length of bar material: 1000 mm



- Inside or outside wiping forms are possible

Dimensions and types

Type BA

Way wipers of this type are used mainly in those cases where installation conditions are restrictive, or where the wipers are additionally protected by means of a telescopic cover, a bellows, a link apron cover, or where no chips occur.

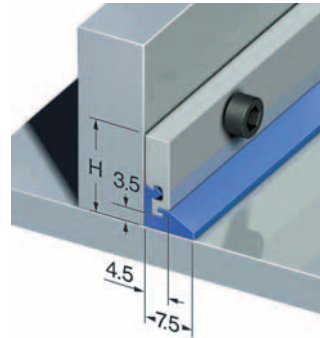

Type	Installation height H (clamped in position)
BA 18	17.5
BA 25	23.5

Standard length: 1000 mm

Type BAS

In this type series, the light metal support provides protection for the wiper lip. It is used primarily in the case of direct incidence of chips (no hot chips).

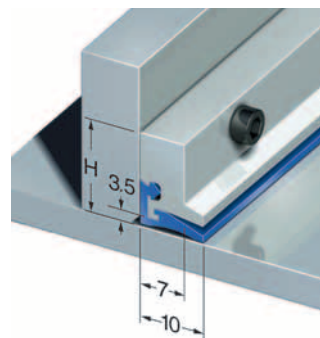

Type	Installation height H (clamped in position)
BAS 18	17.5
BAS 25	23.5
BAS 40	39.5

Standard length: 1000 mm

Pre-wiper for protection of the guideway

To protect the wiper lip from hot chips, and to remove coarse and stubborn dirt from the guideway, the way wiper must be fitted with a pre-wiper made from stainless spring steel or brass.

The pre-wiper and its corresponding light metal clamping strip are affixed to the machine component with the fastening screws of the wiper.

For straight way wipers with a corresponding hole pattern (distance between holes ≤ 80 mm), the clamping strip is not required.

The enquiry form can be found on page 79.

Way wiper BA 65 – bar material.

Wipers of this type are compact and are notable for high shape accuracy and dimensional accuracy.

It is manufactured in various forms, thus guaranteeing high repeatability.

Properties

- Temperature resistance – 40 °C to + 100 °C, briefly up to 140 °C
- Support material: Steel
- Wiper lip material: Abrasion-resistant synthetic rubber (NBR)
- Resistant to standard oils, greases, acids and bases
- Resistant to microorganisms

Dimensions

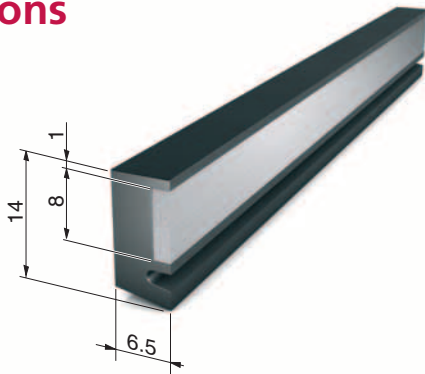

■ Way wiper BA 65-14

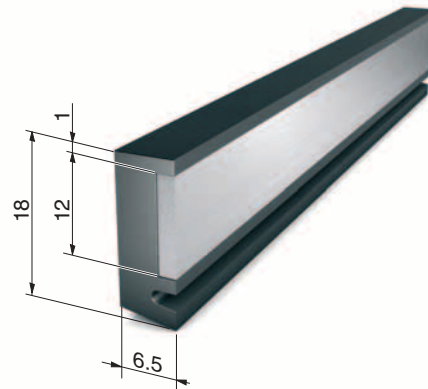

■ Way wiper BA 65-18

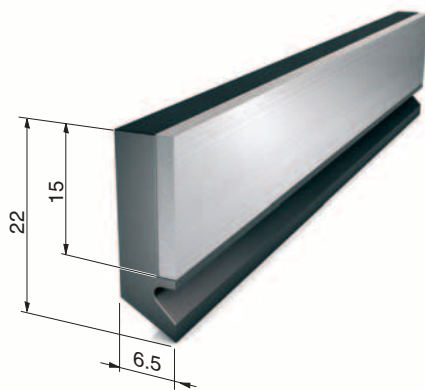

■ Way wiper BA 65-22

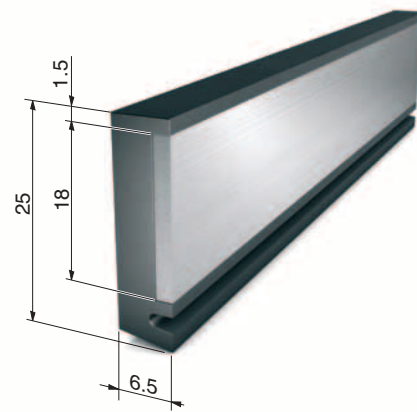

■ Way wiper BA 65-25

Type	Pretension (max.)
BA 65-14	1 mm
BA 65-18	1 mm
BA 65-22	2 mm
BA 65-25	1 mm

Length: 500 mm

The enquiry form can be found on page 79.

Way wiper BA 115 – bar material.

Highly flexible wiper with a max. pretension of 4 mm.

It is likewise manufactured in various forms, guaranteeing high repeatability.

Properties

- Temperature resistance – 40 °C to + 100 °C, briefly up to 140 °C
- Support material: Steel
- Wiper lip material: Abrasion-resistant synthetic rubber (NBR)
- Resistant to standard oils, greases, acids and bases
- Resistant to microorganisms

Dimensions

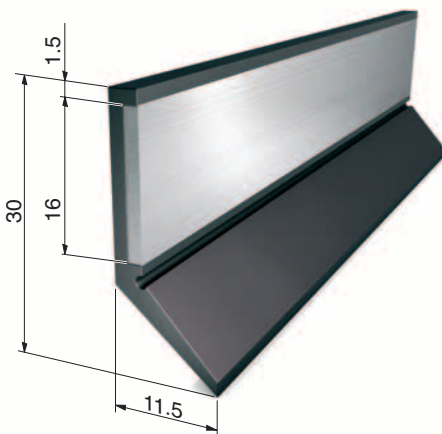

- Way wiper BA 115-30

Type	Pretension (max.)
BA 115-30	4 mm

Length: 500 mm

The enquiry form can be found on page 79.

Way wiper BA 65 VARIO

The most economical alternative to cast wipers – even for small quantities. On request we also manufacture them according to your specifications – custom tailored for your application.

BA 65 VARIO way wipers are optionally available as complete wipers, or as individual wiper lips in bar form for your own harnessing.



So-called **"cast wipers"** are wipers consisting of a piece of neoprene rubber vulcanised onto a steel support profile. They are produced in specially-manufactured injection moulds. Larger quantities are essential, as the tool costs must be offset by the number of parts produced.

The wiper system **BA 65 VARIO** is a new development for which no special tools are required: A pre-finished profile of synthetic rubber is custom-tailored. The support profile – usually made from metal – can be produced on a laser or nibbling machine.

Thus smaller quantities can be produced in this way at a reasonable cost.

Properties

- Temperature resistance – 40 °C to + 100 °C, briefly up to 140 °C
- Support material: Steel, stainless steel
- Wiper lip material: Abrasion-resistant synthetic rubber (NBR)
- Resistant to standard oils, greases, acids and bases
- Pretension of the wiper lip: max. 1 mm
- Resistant to microorganisms

The enquiry form can be found on page 79.

Dimensions

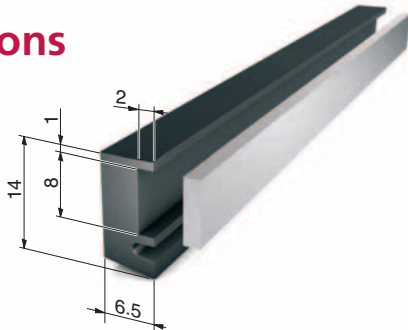

■ Way wiper BA 65-14 VARIO

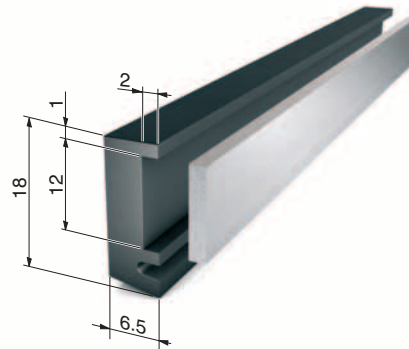

■ Way wiper BA 65-18 VARIO

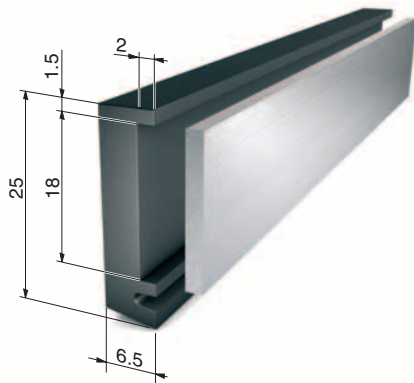

■ Way wiper BA 65-25 VARIO

Type	Pretension (max.)
BA 65-14	1 mm
BA 65-18	1 mm
BA 65-25	1 mm

Length: 500 mm

Delivery options

1. Construction set as individual parts

The support material and wiper lips are produced according to your specifications, and put together as a construction set.



■ Easy assembly of the individual parts

2. Ready-to-install wiper system

All parts are supplied affixed to the support profile.



■ Ready-to-install wiper system

3. Separate wiper lip

If your production department can produce the required support plates itself, you can order the wiper lip from us separately. The delivery length is 500 mm.

It can be ordered as follows:

....pcs.	wiper lip	BA 65-14	material no.	79000
....pcs.	wiper lip	BA 65-18	material no.	79001
....pcs.	wiper lip	BA 65-25	material no.	79003



■ Wiper lip bar material

Way wiper BAY-WIPE.

System with optimised corner design.

Many wiper systems have problems at the point where a hydrostatic guideway goes round a corner. Rounded or bevelled corners on guideways are often problem areas, because the wiper elements cannot follow the profile closely enough.

Our BAY-WIPE system now has these problem areas perfectly under control. Thanks to its optimised corner elements, which follow the contours of the path exactly, the guideway is wiped clean in both directions.

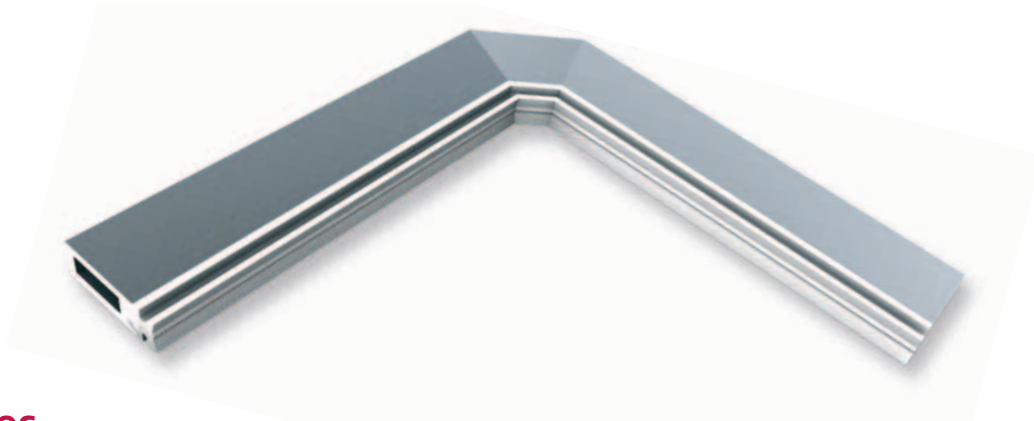

Properties

- Effectively prevents lubricants and coolants from escaping
- Corner elements to ensure perfect contact
- Modularly configured wiper system
- Max. 0.3 mm deformation of wiper edge
- Grease- and acid-resistant wiper lip
- Standard length of bar material: 500 mm

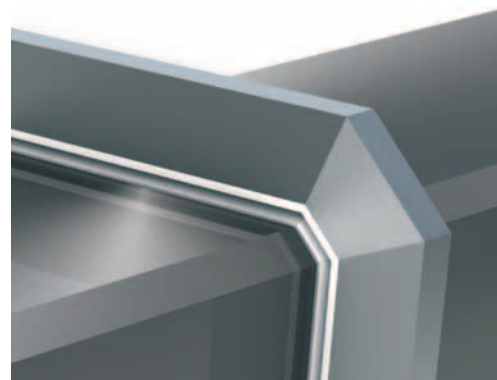

Intelligently designed, individually produced

The wiper lip of the BAY-WIPE was developed at the Institute for Machine Elements (IMA) at the University of Stuttgart.

KABELSCHLEPP participated in this research project, and put the results into practice in a consistent manner.

A wiper lip that works in both directions is affixed directly to the support profile by means of a plastic injection moulding process. The straight sections of this profile, which have been cut to length, are then non-positively joined with pre-assembled corner

elements. This allows a wiper system to be created from the individual parts, exactly suited to the contours of the guideway.

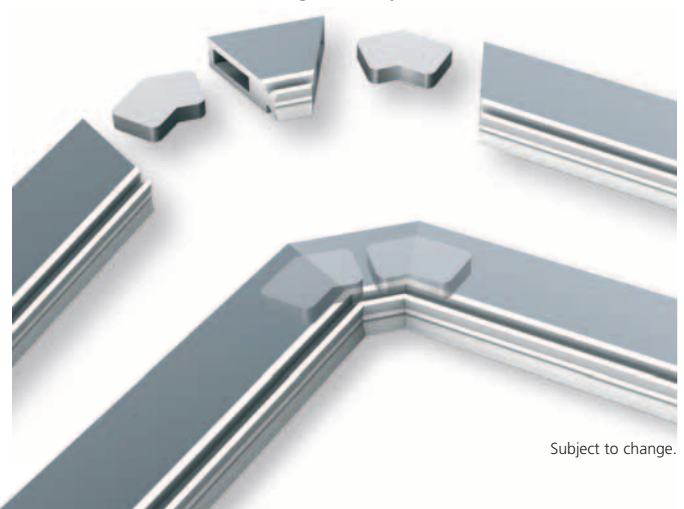

The enquiry form can be found on page 79.

Link apron covers.

Solutions for limited spaces.

Link apron covers can be used anywhere where, for reasons of space, it is not possible to use telescopic covers. They lie directly on

the guideways and can hang down freely at the end of the path, or be screwed on or wound around without any special guides.



Properties

- Small space requirement
- Protection against chips and lubricant
- Splash- and hose-proof
- Low weight
- Long service life
- Heat-resistant to 100 °C over extended periods
- Customized end attachment
- All link apron covers can be supplied with a roller device
- Lateral guides are not necessary
- Short delivery time
- Attractive price/performance ratio

Link apron covers.

Solutions for limited spaces.

Designs

Design 1

Lightweight, highly flexible solid profile link apron covers, thin design.

$B_{min} = 100 \text{ mm}$

$B_{max} = 950 \text{ mm}$

$R_{min} = 25 \text{ mm}$

Weight = 5.6 kg/m²

Solid aluminium profile 19 x 3.0 mm
with PU connecting elements

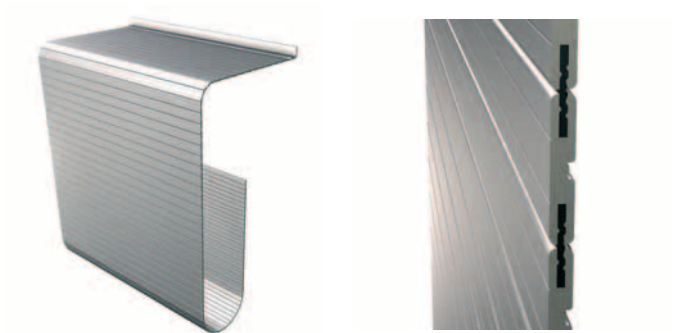

Design 2

Robust solid profile link apron covers, for high stress.

$B_{min} = 100 \text{ mm}$

$B_{max} = 2950 \text{ mm}$

$R_{min} = 50 \text{ mm}$

Weight = 14.2 kg/m²

Solid aluminium profile 20 x 5.5 mm
with PU connecting elements



Design 2N

Lightweight, stable hollow profile link apron covers, extremely stress-resistant, even in large widths.

$B_{min} = 100 \text{ mm}$

$B_{max} = 2950 \text{ mm}$

$R_{min} = 50 \text{ mm}$

Weight = 10 kg/m²

Hollow aluminium profile 20 x 5.5 mm
with PU connecting elements

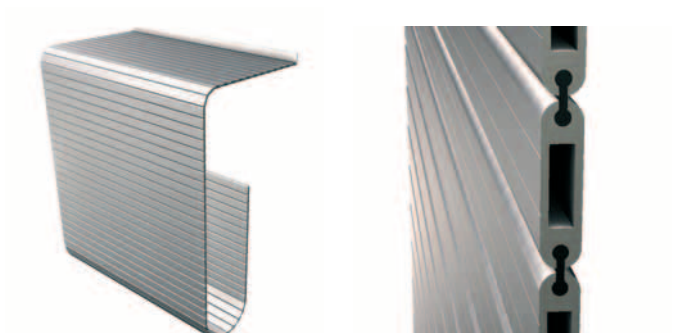

Design 3

Flexible solid metal link apron cover, with hinges and one-sided bend radius.

$B_{min} = 100 \text{ mm}$

$B_{max} = 2000 \text{ mm}$

$R_{min} = 60 \text{ mm}$

Weight = 16.5 kg/m²

Hollow aluminium profile 18.5 x 6.8 mm
with integrated hinge



Fastenings / connecting elements

Examples of fastening profiles



■ Standard end profile



■ Standard profile with mounting bracket



■ Straight end profile



■ Angle fastening profile

Installation variants

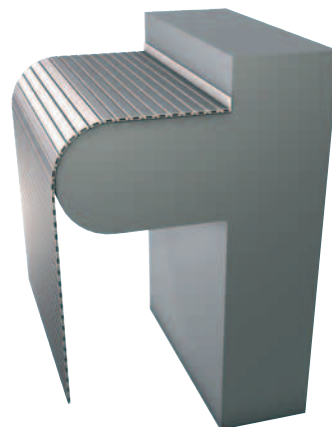
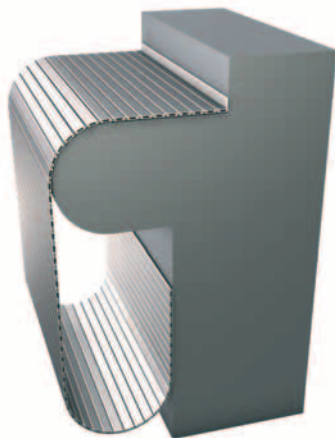

Roller devices

All link apron covers can be rolled up like a window blind.

They can be driven with spring or electric motors.



The enquiry form can be found on page 80.

Steel link apron covers – FLEX-COVER.

Lighter, tougher, more economical.

The new FLEX-COVER link apron cover represents a small revolution: it is made from sheet steel, making it 3 times more robust than aluminium – but weighing the same.

Its completely new construction means that penetration by fluids and chips is virtually impossible. The individual elements roll against each other in the radius of the lamellas.

There is hardly any wear, as there is no friction, and no bendable connection elements that could be exposed to fatigue.

FLEX-COVER gives you improved properties with no increase in weight, and at a considerably lower price.

The specially-milled sheet steel lamellas are held together by a slotted plastic tube, which is itself affixed by means of spring steel clips.

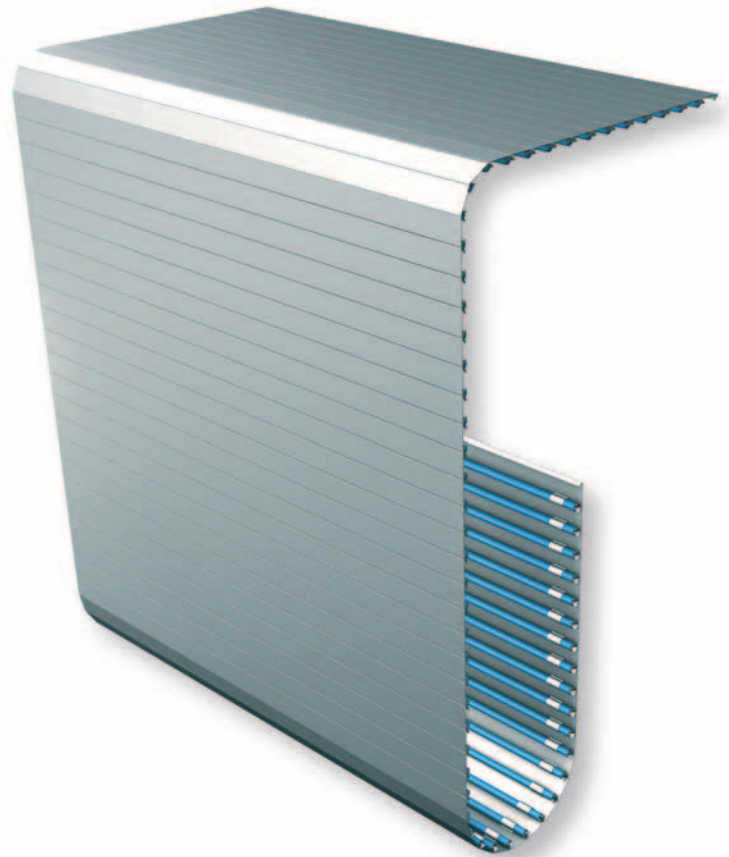

Properties

- Rustproof steel lamellas
- 3 times greater resistance to flying chips
- Each lamella has a completely smooth surface
- Hardly any wear of steel or plastic parts
- Virtually no penetration by chips or fluids

$B_{\min} = 200 \text{ mm}$

$B_{\max} = 2000 \text{ mm}$

$L_{\max} = 2500 \text{ mm}$

$R_{\min} = 50 \text{ mm}$

Weight = 10 kg/m^2

Heat resistance: approx. $80 \text{ }^\circ\text{C}$

Travel speed: 1.5 m/s

Acceleration: up to 15 m/s^2 , depending on the specific application

Bellows.

Guideway protection solutions with very little compression.

KABELSCHLEPP bellows are used on all kinds of machine to provide protection for guideways and spindles, in those cases where no hot chips are present and accessibility is not a requirement.

Bellows can be individually produced from a range of different materials, depending on your specific requirements.



Properties

- Simple installation
- High travel speed
- Minimal compression
- High quality

Installation variants

- Horizontal, lying
- Horizontal, hanging
- Vertical

Delivery options

- For travel speeds of up to 1.5 m/s
- Customized production
- Available in a wide range of shapes
- Available in many different materials

Bellows.

Guideway protection solutions with very little compression.

Designs

U-bellows design

- Variable dimensions
- Customized in the guide
- Economically priced



■ U-bellows design

Box bellows design

- Covering for movable machine elements
- High form stability



■ Box bellows design

U-bellows design with lamellas

- Reliable protection against heavy chip generation
- Rust-resistant and acid-resistant telescopic plates
- Can be made coolant-proof upon request
- Rigid or movable design of the telescopic plates is possible



■ U-bellows design with lamellas

Additional shapes and designs are available on request.

The enquiry form can be found on page 81.

Conical spring covers.

Protection under extreme conditions.

Conical spring covers protect spindles, columns, shafts, threads and rod guides reliably against contamination, chips and mechanical damage. They provide a good sealing function, and are self-cleaning if installed in a

suitable position. High temperature resistance and resistance to chemicals guarantee reliable protection even under extreme operating conditions.



The springs are made of hardened high-quality spring band steel. The optimized design means that the horizontal bending and vertical deflection is very low. Thus even in the

extended state KABELSCHLEPP conical spring covers guarantee excellent protection against dirt and mechanical influences.

Properties

- Accident prevention for operating personnel from revolving spindles and shafts
- Reduction in downtimes resulting from contamination
- Increased machine service life
- Some conical spring covers are also available for retrofitting

Conical spring covers.

Protection under extreme conditions.

Installation positions

The conically wound conical spring covers automatically follow the motions of the machine. Made of high-quality blue polished

steel or alternatively of stainless steel, they can be used in vertical, horizontal and inclined positions.

Vertical installation

When installed vertically, conical spring covers are mounted with the larger diameter at the top. This way the overlapping of the individual coils makes the conical spring covers self-cleaning.



Horizontal installation

When installed horizontally, conical spring covers are mounted with the larger diameter in the direction of the chip generation. In horizontal installation with larger diameters or longer expansion, the maximum expansion is reduced to 60% of the value for vertical installation.

Moreover, a slight sag appears in the conical spring cover, which is about 2 - 5% of the maximum expansion.



Installation in inclined position

In addition to vertical and horizontal installation, installation in an inclined position is also possible. For small angles of incline above the horizontal the same conditions apply as in horizontal installation.



Installation of several conical spring covers in series

By connecting several conical spring covers in series it is possible to deal with special requirements, such as extra-long traversing distances.

We would be happy to advise you regarding such applications and can supply you with the necessary special flanges.

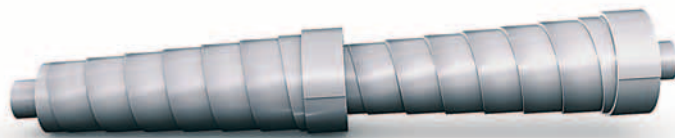

Retrofitting

Many conical spring covers are also available for retrofitting.

Selection

Selection of the conical spring cover suitable for your specific application is generally based on the following criteria:

- Internal diameter D_1
- Expansion AZ (vertical / horizontal)
- Compression ZD

The enquiry form can be found on page 82.

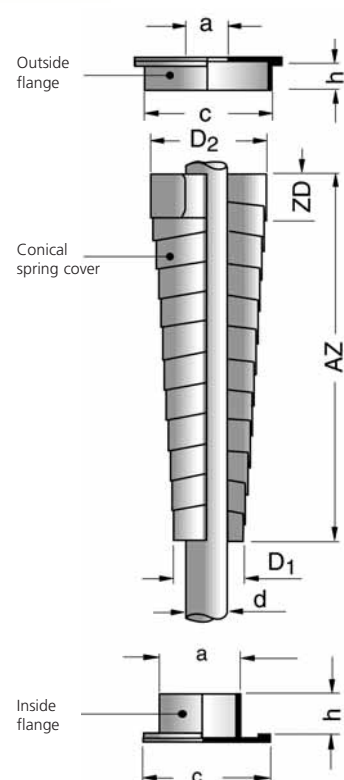

Roll-up covers.

Protection in a minimum of space.

KABELSCHLEPP roll-up covers serve to protect contact surfaces and guideways on all kinds of machine.

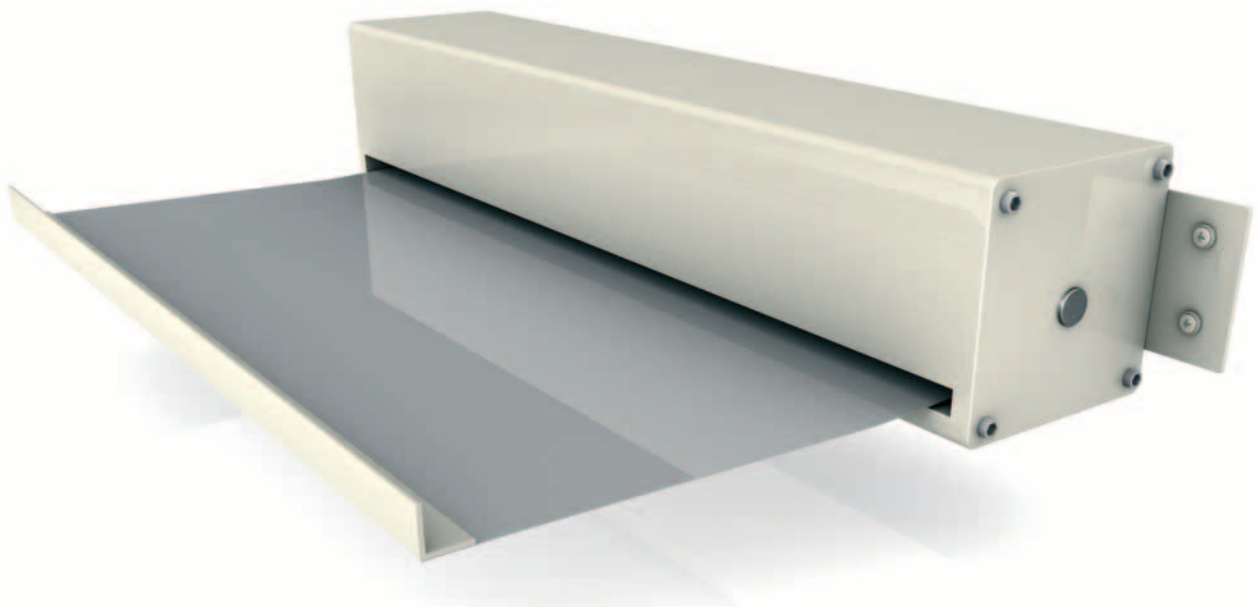

Properties

- For high travel speeds
- Minimal space required
- Customized production
- Simple installation
- Long service life
- Cost-effective

Designs

Roll-up cover without housing

Roll-up covers without a housing are suitable for areas with limited space, and facilitate optimal integration into the machine enclosure.

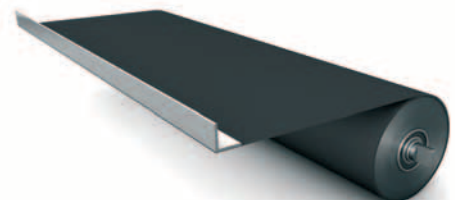

Roll-up cover with housing

Roll-up covers with an additional housing made of steel or aluminium protect the standard roll-up cover and allow simple installation or retrofitting.

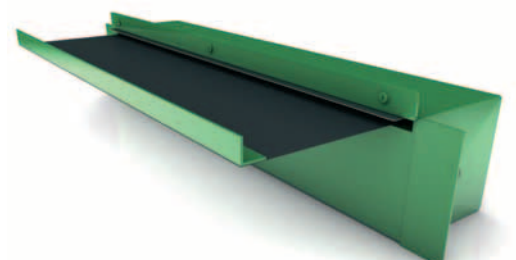

Roll-up covers with plastic band

- Reliable protection against cutting waste, oil and cooling emulsions
- Particularly suitable for high travel speeds thanks to its low own weight
- Minimal space required
- Very resistant to tearing due to plastic layered special fabric
- Various materials are possible

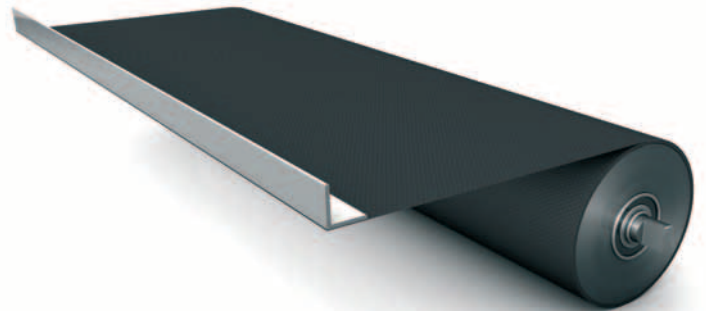

Roll-up covers with steel band

- Very good protection against cutting waste, oil and cooling emulsions
- Rust-resistant and acid-resistant spring band steel with thickness from 0.2 to 0.4 mm
- Suitable for high travel speeds and greater mechanical loads
- Only available with housing

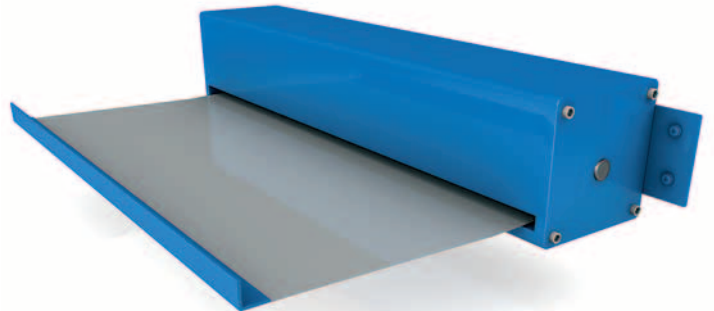

The enquiry form can be found on page 83.





Machine housings.

The “impenetrable” housing for your machines.



	Page
PROTECT-PANEL	62

PROTECT-PANEL system.

The "impenetrable" housing for your machines.

High speeds, quick machining cycles, cooling water and chips: Machine tools represent a dangerous environment for people. This is why all machine tools are contained in nearly "impenetrable" housings.

These help reduce or eliminate the hazards for the persons who work with them.

With the KABELSCHLEPP PROTECT-PANEL system, we offer you optimized protection for a particularly attractive price.



Steel plate construction for a totally harmonised system

Each machine housing is produced individually according to your plans – while at the same time consisting of standardised parts. We carry out all of our engineering in 3D, combining various predefined elements to form your housing. Simple, specially developed connecting elements keep the walls in line.

The entire system is made of steel. Screwed and riveted connections and a rigorously implemented sandwich construction method are used to turn industrially prefabricated components into extremely stable wall modules, without any need for welding. The wall elements are mounted vertically on solid C-profiles with fastening elements, e.g. on the shop floor. Irregularities in the floor can be compensated for using the adjustment features.

This manufacturing method offers you numerous advantages: Short design engineering times through the use of standardised parts wherever possible. Short delivery times, since our production is based on predefined processes. Short installation times, since our mounting profiles are likewise standardised, and the large wall elements can be connected with just a few screws. Processing on state-of-the-art machine tools provides high precision for all elements. Avoiding welding as much as possible eliminates the potential for distortion and irregularities.



KABELSCHLEPP PROTECT-PANEL

Modules:

- Wall modules
(standard dimensions B x H 1235 x 2350 mm)
- Window modules
(with special glass pane insert)
- Corner modules
- Standard doors
- Sliding doors (manual and automatic)
- Folding doors (up to three wings are electric motor-driven under PLC control)
- Lift gates (up to four segments)
- Roll gates (for vertical and vertical-horizontal motion)
- Material: Steel plate, 0.5 mm thick, powder coated (colour as desired, RAL 9002 is standard)

PROTECT-PANEL system.

The “impenetrable” housing for your machines.

PROTECT-PANEL: Secure protection against water spray

The unique connecting element means that the individual wall elements are sealed against water spray, and are joined to each other in an extra-sturdy manner. Each pair of modules is joined by specially-formed plates held together by bolts. An additional plate on the inside forms a labyrinth seal.

In order to direct the remaining water spray downwards, we have fitted a deflector plate which guides the downward-flowing water directly into a particle conveyor, for example. The special sandwich construction of the wall elements, together with the deflector plate, result in a sealed protective wall which can withstand even high water pressures.

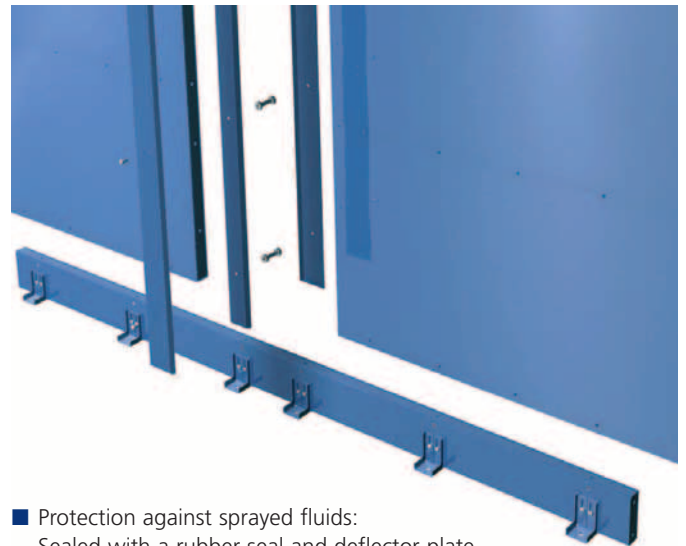

■ Protection against sprayed fluids:
Sealed with a rubber seal and deflector plate.

An open road for your workpieces with modern drive technology

To make exchanging workpieces easier, and if it is not possible to implement a guide rail in the upper and lower areas of the enclosure, then you can equip the enclosure with a folding door which moves to the side. The folding door is suspended only from a lateral post, leaving the greatest possible open space for your workpieces, especially in the upwards direction.

The door elements have the same design as the wall elements. Each of them is driven by a 24 V DC motor with a planetary gear unit and integrated PLC controller. Country-specific voltages can easily be obtained using an appropriate transformer.

Modern CAN-BUS technology makes it possible to program different motion patterns for individual door elements. Teaching and loading of programs are remarkably simple. If suitable CAN-BUS equipment is present, the motors can also be monitored using the machine controller. When closed, the doors are held together by a locking mechanism, and will not open even if a person leans on them, for example. The end positions can be monitored and interrogated either via the program, or by means of additional limit switches.

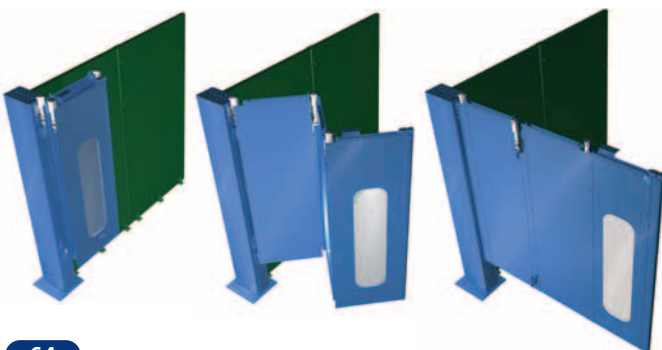

Gate elements for housings

Roll gate for PROTECT-PANEL

For changing pallets on machine tools, a gate is required that moves at high speeds when opening and closing. The PROTECT-PANEL roll gate functions in principle like a garage door. A segmented gate moves upwards and is rolled up. The height of the gate structure is 3500 mm.

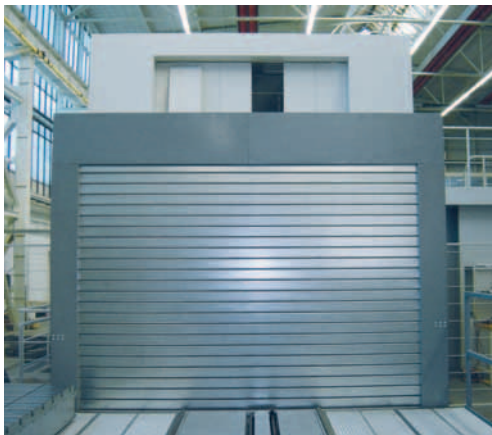

The lamellas of this gate are made from aluminium, and are reinforced on the inside with steel inserts. This guarantees the required penetration resistance.



Lift gate for PROTECT-PANEL

Unlike the roll gate, the lift gate has a small number of larger segments, which all move together. The segments have a sandwich construction, which makes them extremely

resistant to penetration. These larger segments are thus not rolled up, but instead are positioned one behind the other, and hang neatly one behind the other when the door is open.

A special feature of this gate is its lifting and lowering mechanism, which makes use of pulleys. Each gate element is suspended on two pulleys, which raise or lower all of the elements evenly.



PROTECT-PANEL system.

The “impenetrable” housing for your machines.

Automatic door for PROTECT-PANEL

Because automatic doors are integrated into the machine tool programme, they automatically open and close according to the required production cycle.

For heights of 2-3 m that’s nothing special. But the automatic door in the PROTECT-PANEL system can manage much bigger sizes.



At the production plant of one of our customers, a first automatic door has been installed which is 6500 mm high, 1600 mm wide, 500 kg in weight and can open and close

within 5 seconds. It’s a challenge that we solved perfectly with the help of linear drives, a three-phase motor and control shaft technology.

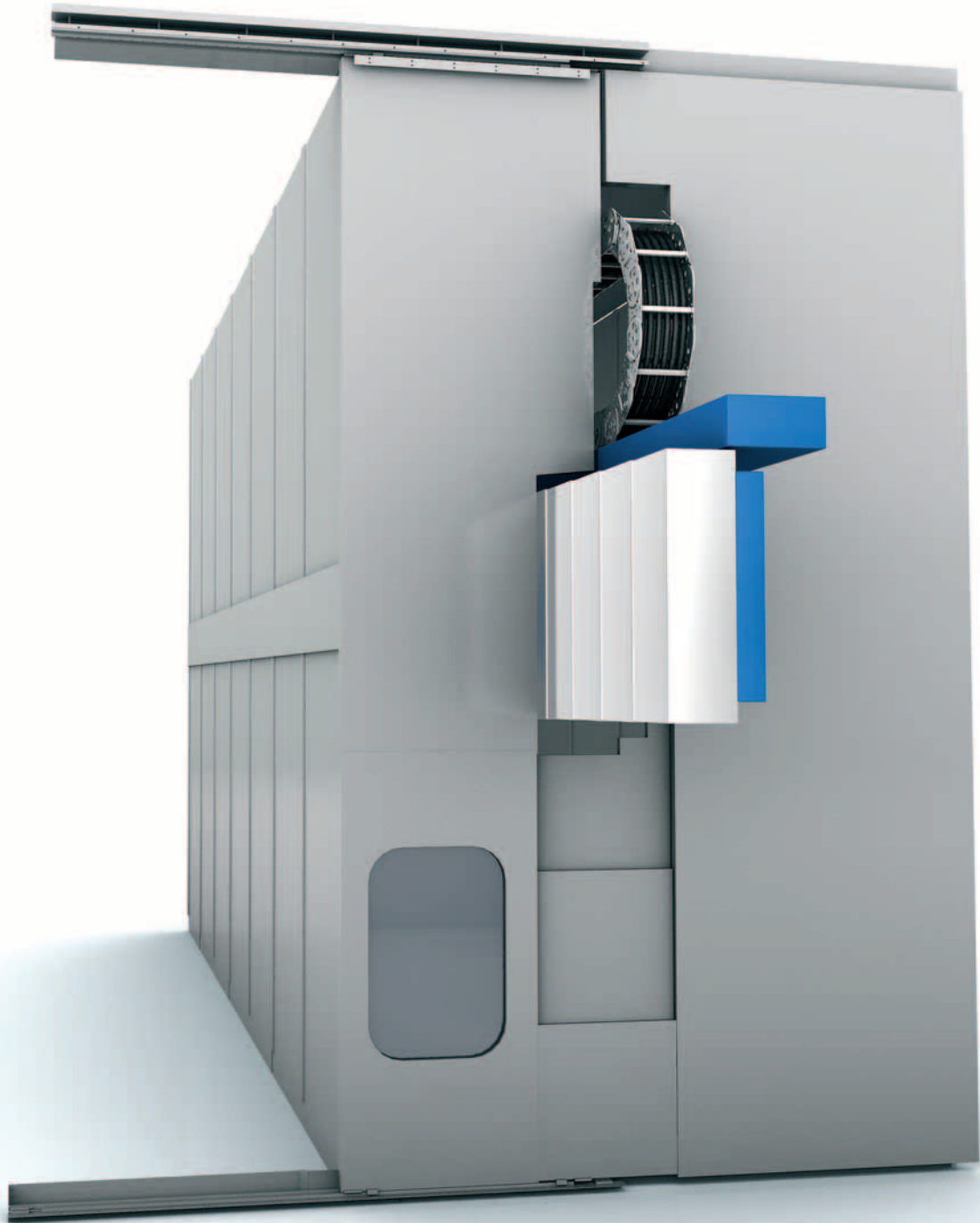

Hinged belt conveyors question form.

Purpose of the conveyor: _____

Material to be conveyed: _____

Type of material to be conveyed (for chips, type of chips): _____

Max. dimensions of material to be conveyed _____

Material: _____

Output: _____ m³/h _____ kg/h

Coolant:

Type of coolant: Emulsion Oil _____

Quantity of coolant _____ l/min

Coolant container: On conveyor housing

Separate container

With pump

With float bracket

Electrical connection values:

Operating voltage: _____ volts

Control voltage: _____ volts

Frequency: _____ Hz

Electrical control

Supplied by KABELSCHLEPP GmbH

Material to be provided by customer

Design of control _____

Overload safety

Electrical overload protection (e.g. motor protection switch)

Current monitoring relay

Torque switching via limit switch
(only when conveyor driven by attachable gear motor)

Paintwork

Primer _____

Paint – RAL _____

Design

Straight

Straight/rising

Straight/rising/straight



■ **Straight design**
Horizontal or rising
Max. incline 45°



■ **Straight/rising design**
Max. incline 45°



■ **Straight/rising/straight design**
Max. incline 60°

Straight

Section A-B



Constructio

Overall leng

Box height

Box width

Belt width

Panel height

Additional

Straig

Section



Constr

Overall

Field le

Distanc

Box he

Box w

Belt w

Panel

Alph

Dist

Addi

Enquiry forms.

Question forms and technical information.

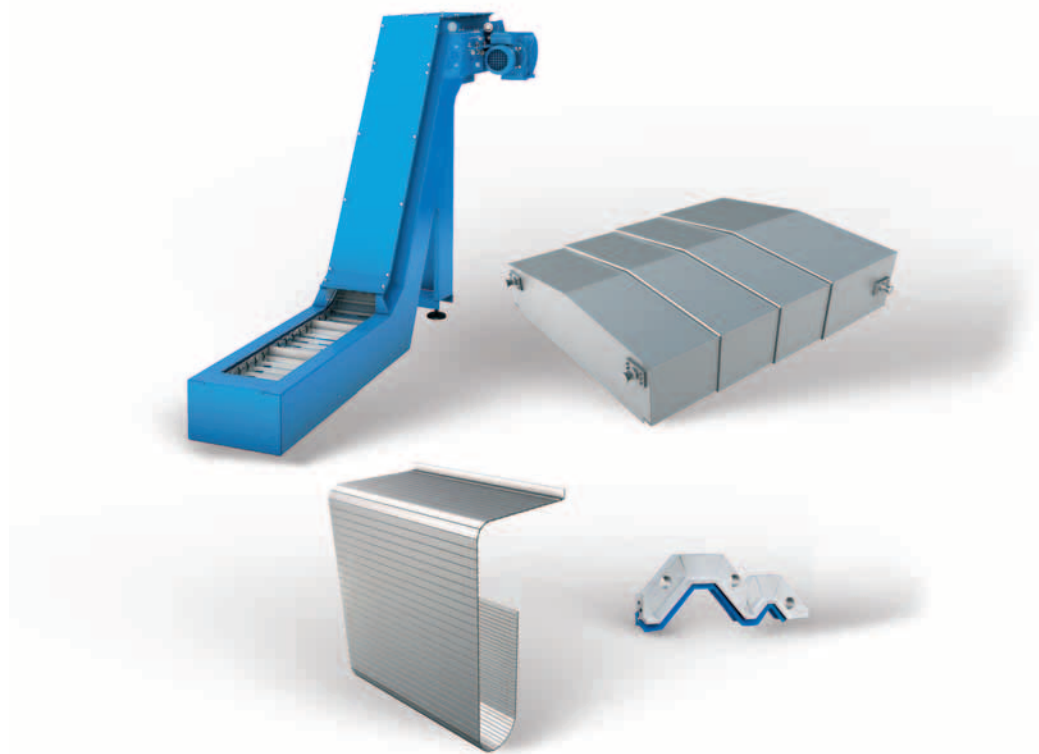

	Page
Hinged belt conveyors question form	70
Scraper conveyors question form	72
Belt conveyors question form	74
Telescopic covers question form	75
Telescopic covers technical information question form	76
Way wipers question form	79
Link apron covers question form	80
Bellows question form	81
Conical spring covers question form	82
Roll-up covers question form	83

Hinged belt conveyors question form.

Purpose of the conveyor: _____

Material to be conveyed: _____

Type of material to be conveyed (for chips: type of chip): _____

Max. dimensions of material to be conveyed: _____

Material: _____

Output: _____ m³/h _____ kg/h

Coolant:

Type of coolant: Emulsion Oil _____

Quantity of coolant: _____ l/min

- Coolant container: On conveyor housing
 Separate container
 With pump
 With float bracket

Electrical connection values:

Operating voltage: _____ volts

Control voltage: _____ volts

Frequency: _____ Hz

Electrical control

- Supplied by KABELSCHLEPP GmbH
 Material to be provided by customer
Design of control _____

Overload safety

- Electrical overload protection (e.g. motor protection switch)
 Current monitoring relay
 Torque switching via limit switch
 (only when conveyor driven by attachable gear motor)

Paintwork

Primer _____

Paint – RAL _____

Design

- Straight
 Straight/rising
 Straight/rising/straight

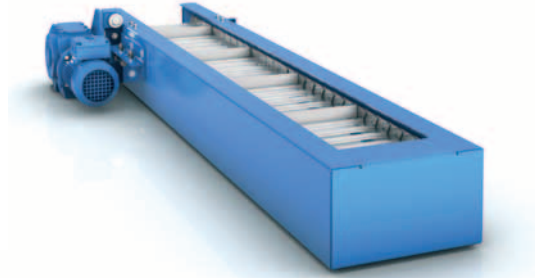

■ **Straight design**
Horizontal or rising.
Max. incline 45°



■ **Straight/rising design**
Max. incline 45°



■ **Straight/rising/straight design**
Max. incline 60°

Straight design

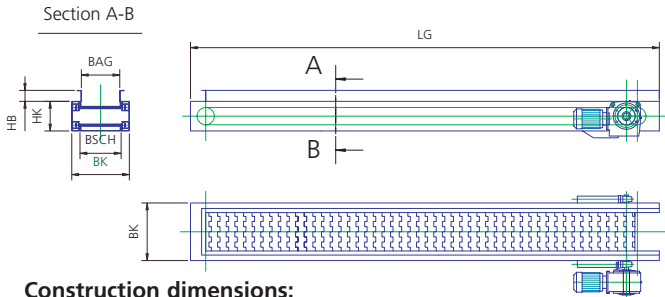

Construction dimensions:

Overall length L_G : _____ mm
 Box height H_K : 140 mm (SRF 040.00)
 216 mm (SRF 063.00)
 360 mm (SRF 100.00)

Box width B_K : _____ mm
 Belt width B_{SCH} : _____ mm
 Panel height H_B : _____ mm

Additional information

Straight/rising design

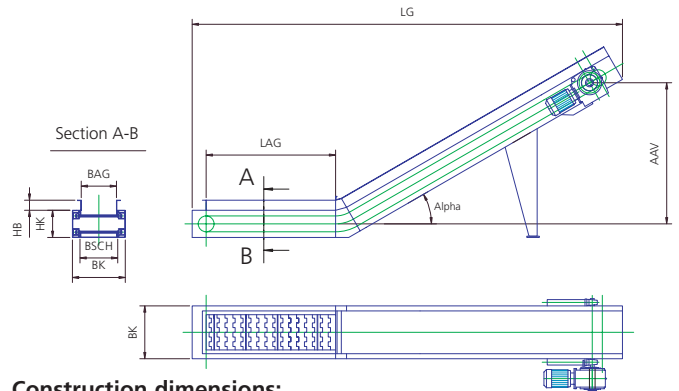

Construction dimensions:

Overall length L_G : _____ mm
 Feed length L_{AG} : _____ mm
 Distance between axles, vertical A_{AV} : _____ mm
 Box height H_K : 140 mm (SRF 040.00)
 216 mm (SRF 063.00)
 360 mm (SRF 100.00)

Box width B_K : _____ mm
 Belt width B_{SCH} : _____ mm
 Panel height H_B : _____ mm
 Alpha: _____ mm

Additional information

Straight/rising/straight design

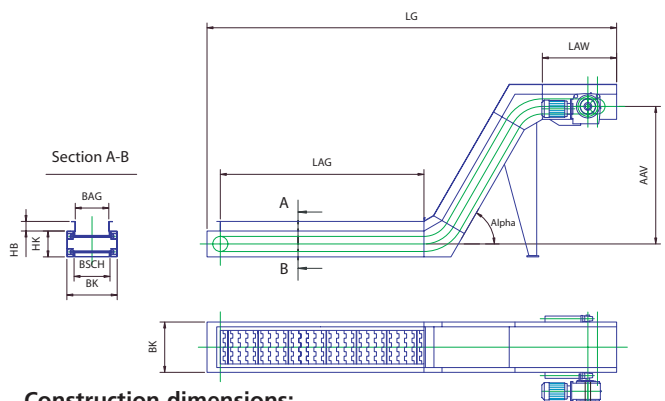

Construction dimensions:

Overall length L_G : _____ mm
 Feed length L_{AG} : _____ mm
 Distance between axles, vertical A_{AV} : _____ mm
 Box height H_K : 140 mm (SRF 040.00)
 216 mm (SRF 063.00)
 360 mm (SRF 100.00)

Box width B_K : _____ mm
 Belt width B_{SCH} : _____ mm
 Panel height H_B : _____ mm
 Alpha: _____ mm
 Discharge length L_{AW} : _____ mm

Additional information

Scraper conveyors question form.

Purpose of the conveyor: _____

Material to be conveyed: _____

Type of material to be conveyed (for chips: type of chip): _____

Max. dimensions of material to be conveyed: _____

Material: _____

Output: _____ m³/h _____ kg/h

Coolant:

Type of coolant: Emulsion Oil _____

Quantity of coolant: _____ l/min

- Coolant container: On conveyor housing
 Separate container
 With pump
 With float bracket

Electrical connection values:

Operating voltage: _____ volts

Control voltage: _____ volts

Frequency: _____ Hz

Electrical control

- Supplied by KABELSCHLEPP GmbH
 Material to be provided by customer
 Design of control _____

Overload safety

- Electrical overload protection (e.g. motor protection switch)
 Current monitoring relay
 Torque switching via limit switch
 (only when conveyor driven by attachable gear motor)

Paintwork

Primer _____

Paint – RAL _____

Design

- Straight
 Straight/rising
 Straight/rising/straight

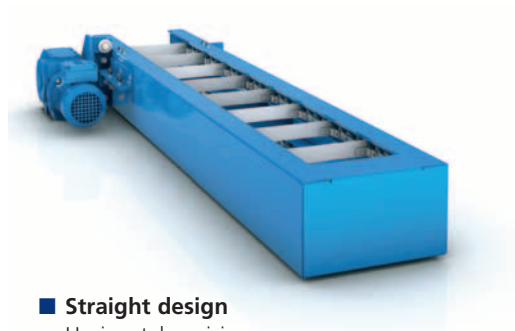

■ **Straight design**
 Horizontal or rising.
 Max. incline 45°



■ **Straight/rising design**
 Max. incline 45°



■ **Straight/rising/straight design**
 Max. incline 60°

Straight design

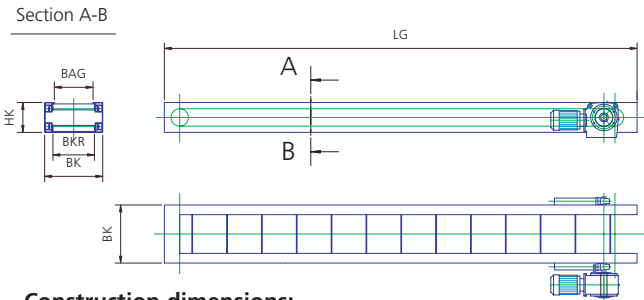

Construction dimensions:

Overall length L_G : _____ mm

Box height H_K : 140 mm (KRF 040.00)
 216 mm (KRF 063.00)
 360 mm (KRF 100.00)

Box width B_K : _____ mm

Belt width B_{KR} : _____ mm

Additional information

Straight/rising design

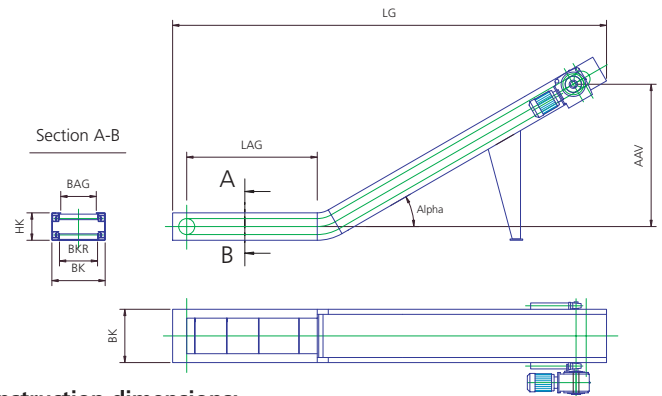

Construction dimensions:

Overall length L_G : _____ mm

Feed length L_{AG} : _____ mm

Distance between axles, vertical A_{AV} : _____ mm

Box height H_K : 140 mm (KRF 040.00)
 216 mm (KRF 063.00)
 360 mm (KRF 100.00)

Box width B_K : _____ mm

Belt width B_{KR} : _____ mm

Alpha: _____ mm

Additional information

Straight/rising/straight design

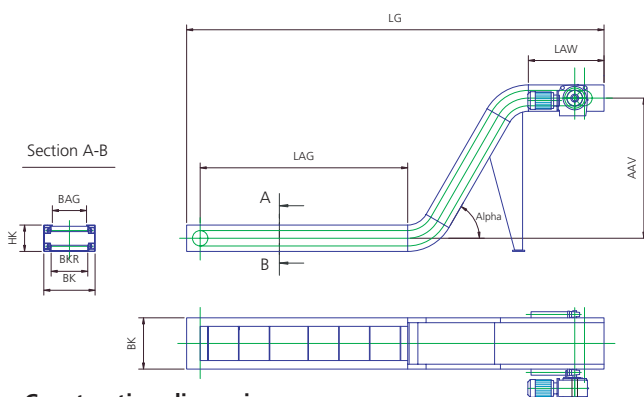

Construction dimensions:

Overall length L_G : _____ mm

Feed length L_{AG} : _____ mm

Distance between axles, vertical A_{AV} : _____ mm

Box height H_K : 140 mm (KRF 040.00)
 216 mm (KRF 063.00)
 360 mm (KRF 100.00)

Box width B_K : _____ mm

Belt width B_{KR} : _____ mm

Alpha: _____ mm

Discharge length L_{AW} : _____ mm

Additional information

Belt conveyors question form.

Purpose of the conveyor: _____

Material to be conveyed: _____

Type of material to be conveyed: _____

Max. dimensions of material to be conveyed: _____

Material: _____

Output: _____ m³/h _____ kg/h

Electrical connection values:

Operating voltage: _____ volts

Control voltage: _____ volts

Frequency: _____ Hz

Electrical control

Supplied by KABELSCHLEPP GmbH

Material to be provided by customer

Design of control _____

Overload safety

Electrical overload protection (e.g. motor protection switch)

Current monitoring relay

Paintwork

Primer _____

Paint – RAL _____

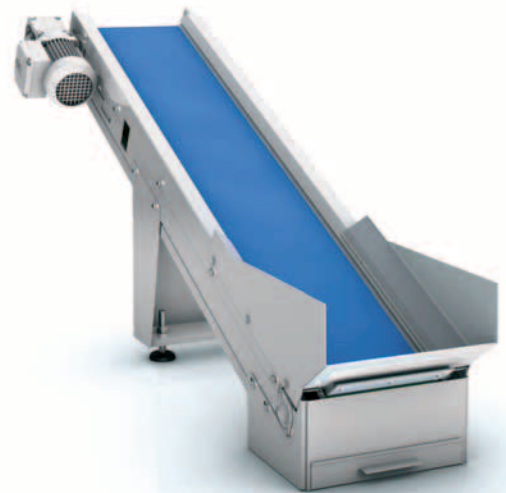

■ **Standard design**
Horizontal or rising.
Max. incline 30°

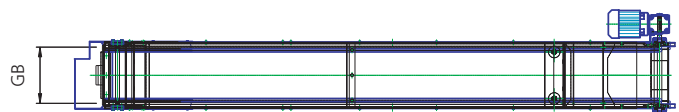
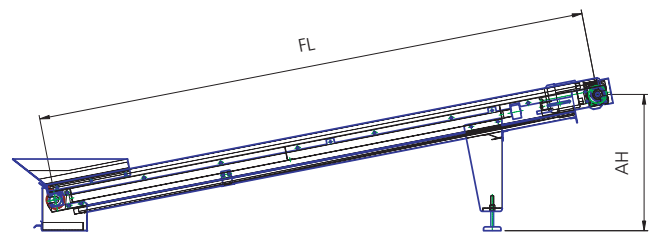

Construction dimensions:

Conveying length FL: _____ mm

Discharge height AH: _____ mm

Belt width GB: _____ mm

Additional information

Telescopic covers question form.

Machine data:

Machine type: _____

Use of telescopic cover:

- Machine base
- Standing
- Cross-beam

Machine travel (travel distance LS_K) _____ mm

Travel speed v : _____ m/s

Acceleration a : _____ m/s^2

Width of guideway B_B : _____ mm

Guideway lubrication:

- Hydrostatic
- Aerostatic
- Other _____



Photograph: Waldrich Siegen Werkzeugmaschinen GmbH

Data for the design of the telescopic cover:

Travel length of telescopic cover L_S : _____ mm

Maximum compression of telescopic cover L_Z : _____ mm

Possible width of the telescopic cover B_A : _____ mm

Possible height of the telescopic cover above the guideway $H_{1,x}$: _____ mm

Possible total height of telescopic cover H_G : _____ mm

Connection of telescopic cover: _____

Wiper with protective strip for protection against hot chips: yes no

Additional information:

Interference contours around the telescopic cover (way wipers, lines, etc.):

Design of the telescopic cover: Not walkable-on Walkable-on when at rest

Quantity of chips: _____ kg/h

Type of chips: _____

Coolant: _____

Type: _____

Quantity: _____ l/min

Can consoles be attached? yes no

Should consoles be attached? yes no

Other information

Technical information on telescopic covers can be found on pages 76 – 78.

Horizontally-installed telescopic covers.

Technical information.

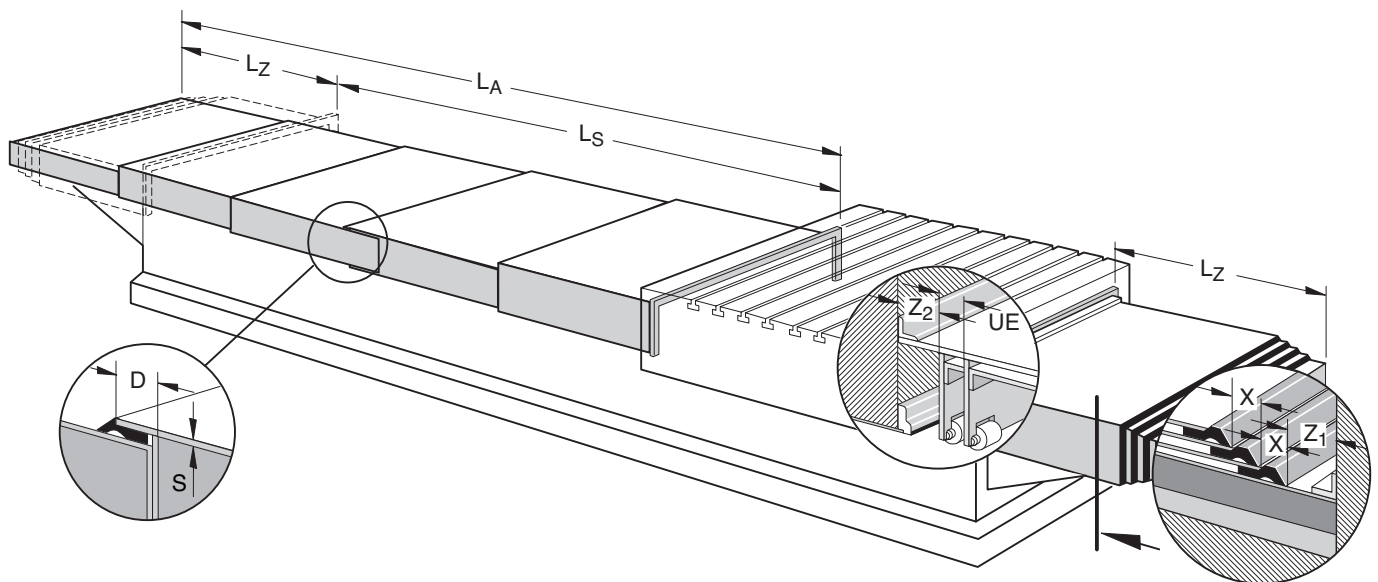

Explanation of terms Technical explanations

B_A = Maximum width of the telescopic cover

B_B = Width of guideway

B_{U1} = Width of undergrip – left

B_{U2} = Width of undergrip – right

h_1 = Thickness of upper bundle of plates

h_2 = Thickness of side bundle

h_3 = Thickness of undergrip bundle

$H_{1,1}$ = Height of telescopic cover above the contact surface – left

$H_{1,2}$ = Height of telescopic cover above the contact surface – right

$H_{2,1}$ = Height of side leg piece – left

$H_{2,2}$ = Height of side leg piece – right

H_G = Total height of telescopic cover

Z_1 = Console plate extension

Z_2 = Support plate extension

v = Travel speed

L_{SK} = Machine travel length

The travel length of the machine is the distance that a moving machine component travels from one end position to the other.

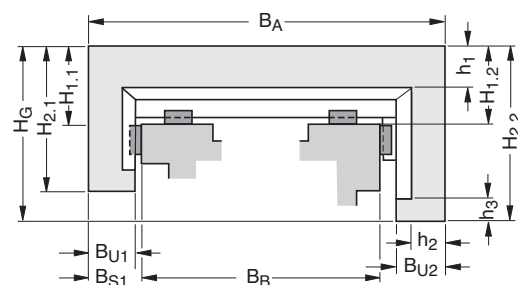

L_S = Travel length of telescopic cover

$$L_S = L_{SK} + \text{reserve}$$

L_Z = Compression

If the individual sheet metal elements are compressed in an end position, then the compression is the length of the bundle of metal plates.

n = Number of plates

s = Plate thickness

D = Sheathing (non-expandable plate length)

UE = Distance between the plates at the support

X = Gradation of metal plate at the driver wiper

l = Plate length

The relationship between the plate length and plate width is selectable up to a ratio of **1:8**.

Vertically-installed telescopic covers.

Technical information.

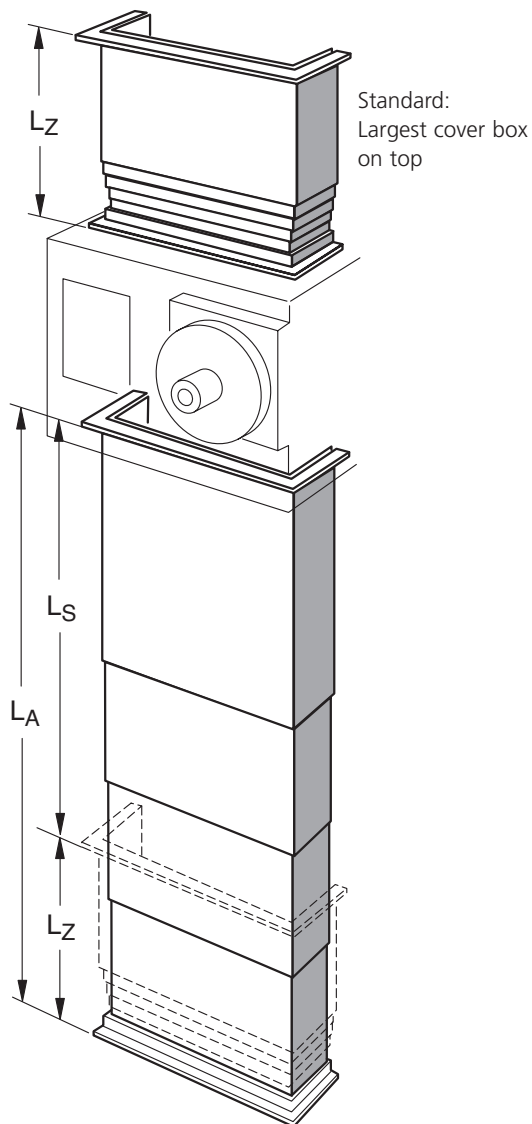

Explanation of terms Technical explanations

- B_A = Maximum width of the telescopic cover
- B_B = Width of guideway
- B_{U1} = Width of undergrip – left
- B_{U2} = Width of undergrip – right
- h_1 = Thickness of upper bundle of plates
- h_2 = Thickness of side bundle
- h_3 = Thickness of undergrip bundle
- α = Angle at undergrip
- $H_{1.1}$ = Height of telescopic cover above the contact surface – left
- $H_{1.2}$ = Height of telescopic cover above the contact surface – right
- $H_{2.1}$ = Height of side leg piece – left
- $H_{2.2}$ = Height of side leg piece – right
- H_G = Total height of telescopic cover
- v = Travel speed
- L_{SK} = Machine travel length
The travel length of the machine is the distance that a moving machine component travels from one end position to the other.
- L_S = Travel length of telescopic cover

$$L_S = L_{SK} + \text{reserve}$$

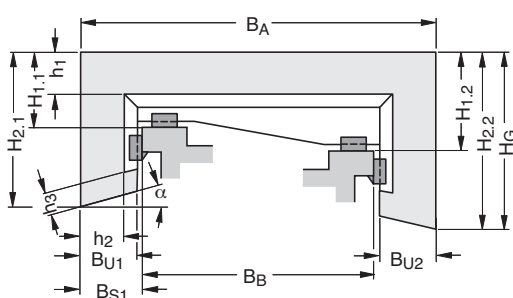

- L_Z = Compression
If the individual sheet metal elements are compressed in an end position, then the compression is the length of the bundle of metal plates.
- n = Number of plates
- s = Plate thickness
- D = Sheathing (non-expandable plate length)
- UE = Distance between the plates at the support
- X = Gradation of metal plate at the driver wiper
- l = Plate length
The relationship between the plate length and plate width is selectable up to a ratio of **1:8**.

Horizontal, handing telescopic covers.

Technical information.

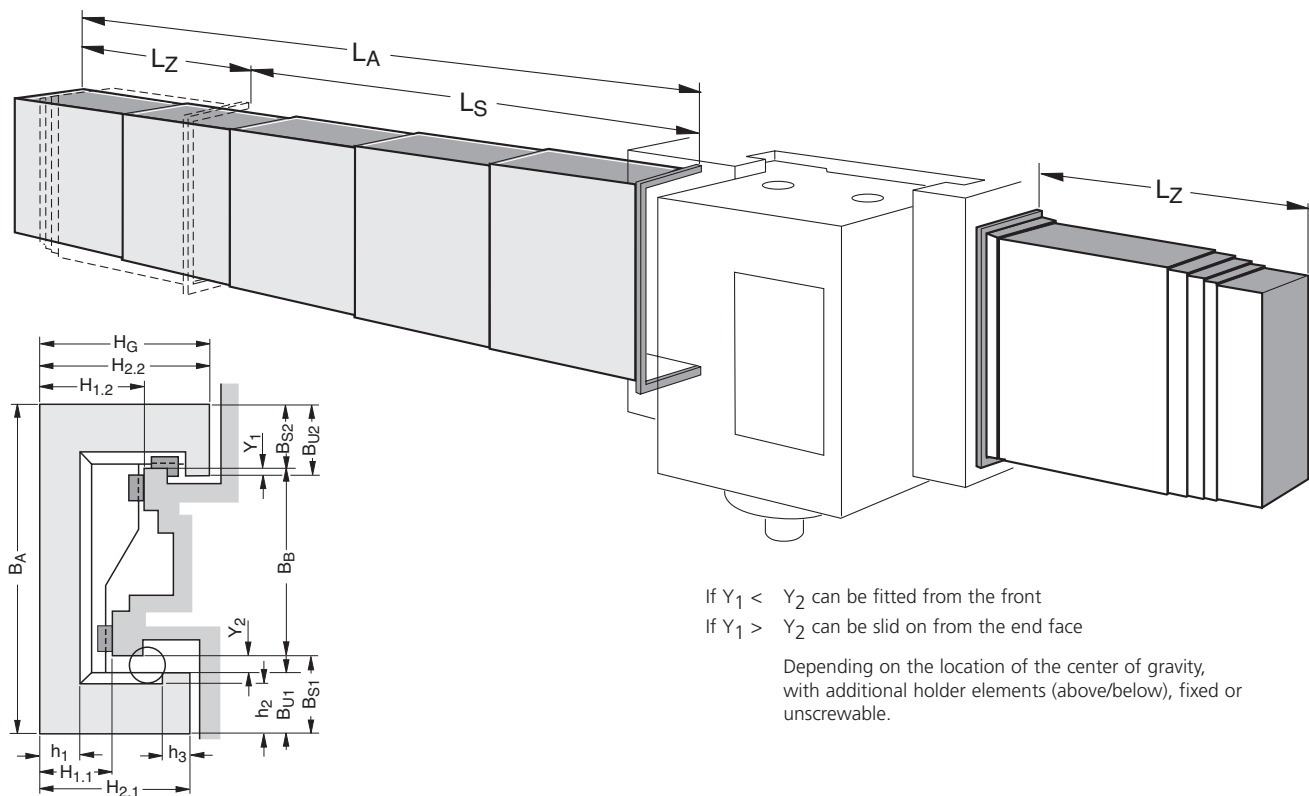

If $Y_1 < Y_2$ can be fitted from the front
 If $Y_1 > Y_2$ can be slid on from the end face

Depending on the location of the center of gravity, with additional holder elements (above/below), fixed or unscrewable.

Explanation of terms Technical explanations

B_A = Maximum width of the telescopic cover

B_B = Width of guideway

B_{U1} = Width of undergrip – left

B_{U2} = Width of undergrip – right

h_1 = Thickness of upper bundle of plates

h_2 = Thickness of side bundle

h_3 = Thickness of undergrip bundle

$H_{1.1}$ = Height of telescopic cover above the contact surface – left

$H_{1.2}$ = Height of telescopic cover above the contact surface – right

$H_{2.1}$ = Height of side leg piece – left

$H_{2.2}$ = Height of side leg piece – right

H_G = Total height of telescopic cover

v = Travel speed

L_{SK} = Machine travel length

The travel length of the machine is the distance that a moving machine component travels from one end position to the other.

L_S = Travel length of telescopic cover

$$L_S = L_{SK} + \text{reserve}$$

L_Z = Compression

If the individual sheet metal elements are compressed in an end position, then the compression is the length of the bundle of metal plates.

n = Number of plates

s = Plate thickness

D = Sheathing (non-expandable plate length)

UE = Distance between the plates at the support

X = Gradation of metal plate at the driver wiper

l = Plate length

The relationship between the plate length and plate width is selectable up to a ratio of **1:8**.

Way wipers question form.

Standard design:

Type	Standard length	Quantity
Type BA 18	1000 mm	_____
Type BA 25	1000 mm	_____
Type BAS 18	1000 mm	_____
Type BAS 25	1000 mm	_____
Type BAS 40	1000 mm	_____
Type BA 65-14	500 mm	_____
Type BA 65-18	500 mm	_____
Type BA 65-25	500 mm	_____
Type BA 115-30	500 mm	_____
Bay-Wipe	500 mm	_____



Harnessed wipers:

Drawing/sketch of the wiper with precise dimensioning

Pre-wiper for protecting the wiper lip against hot chips:

yes no

Environmental conditions (temperature, coolant, dirt, etc.):



Link apron covers question form.

Travel speed: _____ m/min

Length: _____ mm

Width: _____ mm

Designs:

Design 1

$B_{min} = 100 \text{ mm}$

$B_{max} = 950 \text{ mm}$

$R_{min} = 25 \text{ mm}$

Weight = 5.6 kg/m^2

Solid aluminium profile 19 x 3.0 mm with PU connecting elements



■ Design 1

Design 2

$B_{min} = 100 \text{ mm}$

$B_{max} = 2,950 \text{ mm}$

$R_{min} = 50 \text{ mm}$

Weight = 14.2 kg/m^2

Solid aluminium profile 20 x 5.5 mm with PU connecting elements

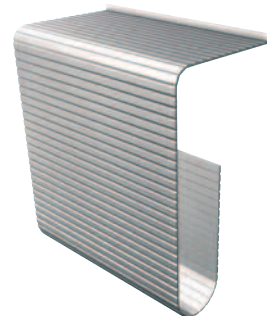

■ Design 2

Design 2N

$B_{min} = 100 \text{ mm}$

$B_{max} = 2,950 \text{ mm}$

$R_{min} = 50 \text{ mm}$

Weight = 10 kg/m^2

Hollow aluminium profile 20 x 5.5 mm with PU connecting elements



■ Design 2N

Design 3

$B_{min} = 100 \text{ mm}$

$B_{max} = 2000 \text{ mm}$

$R_{min} = 60 \text{ mm}$

Weight = 16.5 kg/m^2

Hollow aluminium profile 18.5 x 6.8 mm without PU connecting elements



■ Design 3

End attachment:

Comments:

Bellows question form.

Drawing/sketch of the cross-section to be covered

Travel speed: _____ m/s

Total expansion: _____ mm

Compression: _____ mm

Machine travel: _____ mm

Max. external dimensions: _____ mm

End attachment:

Installation position:

Environmental conditions (temperature, etc.):

Use of emulsions (type and quantity in l/min):

Annual requirements:

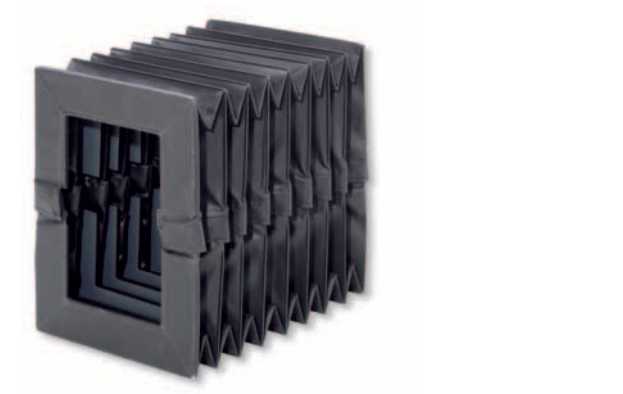

Conical spring covers question form.

Internal diameter: _____ mm
 Travel speed: _____ m/s
 Total expansion: _____ mm
 Compression: _____ mm
 Machine travel: _____ mm
 Max. external dimensions: _____ mm



Material:

- Spring band steel, blue polished
- Stainless steel

Installation position:

Environmental conditions (temperature, etc.):

Use of emulsions (type and quantity in l/min):

Annual requirements:

Type designation

025 – 0100 – 020 V 0

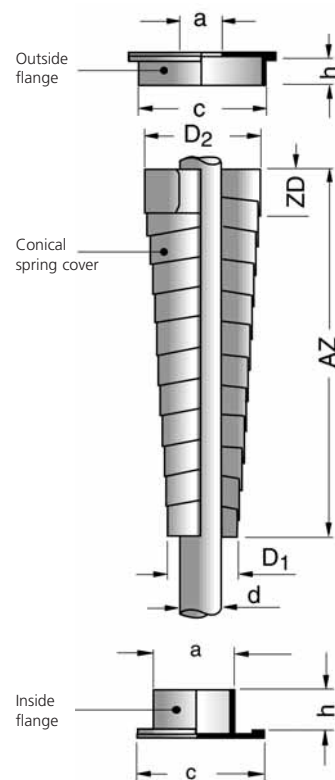
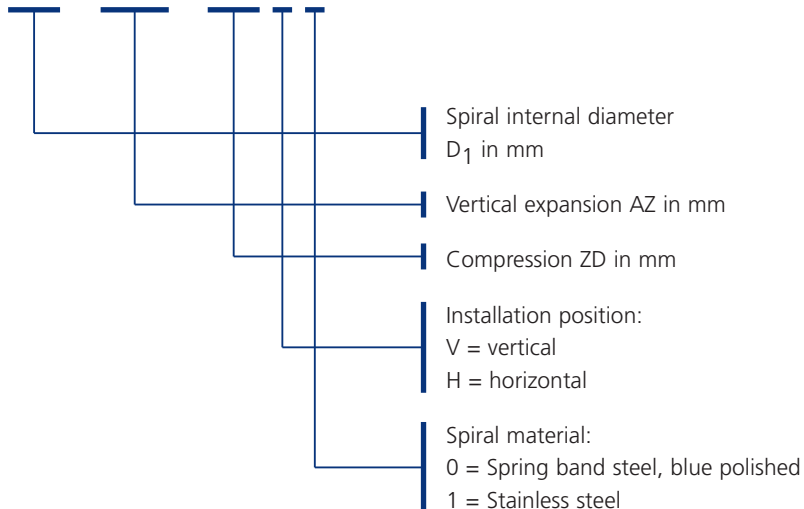

Conical spring cover

- d = Shaft/spindle diameter
- a = Diameter of the guide sleeve
= Hole diameter in the external flange
 $a < D_1 - 4 \text{ mm}$
- D_1 = Spiral internal diameter
- D_2 = Spiral external diameter
- c = External diameter of the internal flange
Internal diameter of the external flange
 $c > D_2 + 6 \text{ mm}$
- h = Flange height ($0.6 \times ZD \leq h \leq (ZD - 2 \text{ mm})$)
- ZD = Compression
- AZ = Expansion / expansion length

The guide flange is not included in the scope of supply, but can be supplied at the same time on request.

When ordering please indicate the installation position and spiral material. See "Type designation".

Roll-up covers question form.

Travel speed: _____ m/s

Total expansion: _____ mm

Machine travel: _____ mm

Belt width: _____ mm

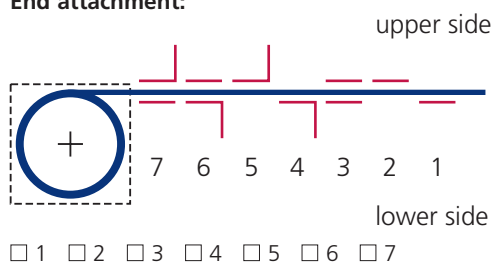
End attachment:

Installation position:

Design:

- With housing
- Without housing

Belt type:

- Stainless steel
- Plastic

Environmental conditions (temperature, emulsions, etc.):

Annual requirements:

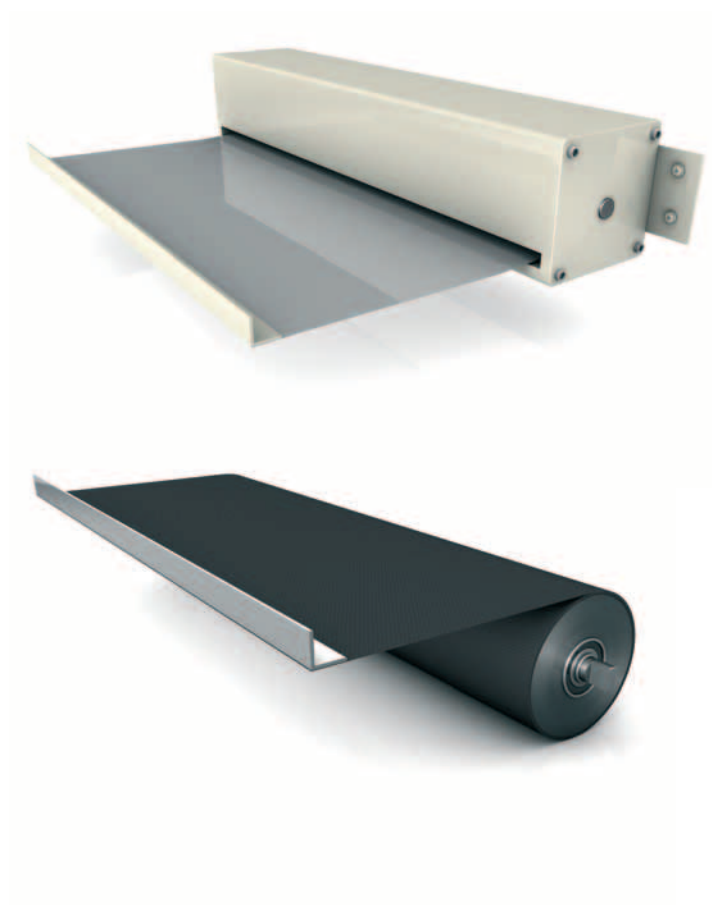

Cable and hose carrier systems

Cable carriers made of steel and plastic
QUANTUM cable and hose carrier system
PROTUM cable and hose carrier system
PROFILE cable and hose carrier system
ROBOTRAX cable and hose carrier system
LIFE-LINE cable systems
TOTALTRAX turn-key systems

Guideway Protection Systems

Telescopic covers
Link apron covers
Way wipers
Conical spring covers
Bellows

Conveyor systems

Hinged belt conveyors
Scraper conveyors
Belt conveyors

KABELSCHLEPP GmbH

Marienborner Str. 75
D-57074 Siegen
Tel.: +49 271 5801-0
Fax: +49 271 5801-220
E-mail: info@kabelschlepp.de
www.kabelschlepp.de

KABELSCHLEPP worldwide

For contacts, addresses
and much more, visit our
web site at www.kabelschlepp.de