

Software



Picture by PC 3.0

Block 10 (Gewindebohrer)

ZOOM=+161.7112,-7.5049,-1827.1162,499.70...

1

+1



SOFTWARE

Software and
control organization..... 4-2

CAD/CAM software
isy-CAM 2.5 PLUS 4-4

Interpreter software
Remote 4-5

Programming software
ProNC 4-6
PAL-PC 2.1 4-7

Software and controller organisation

- CAD/CAM Software
- Operating and programming software (text format)
- Operating and programming software (graphics format)
- Interpreter software
- DLL concept
- Hardware

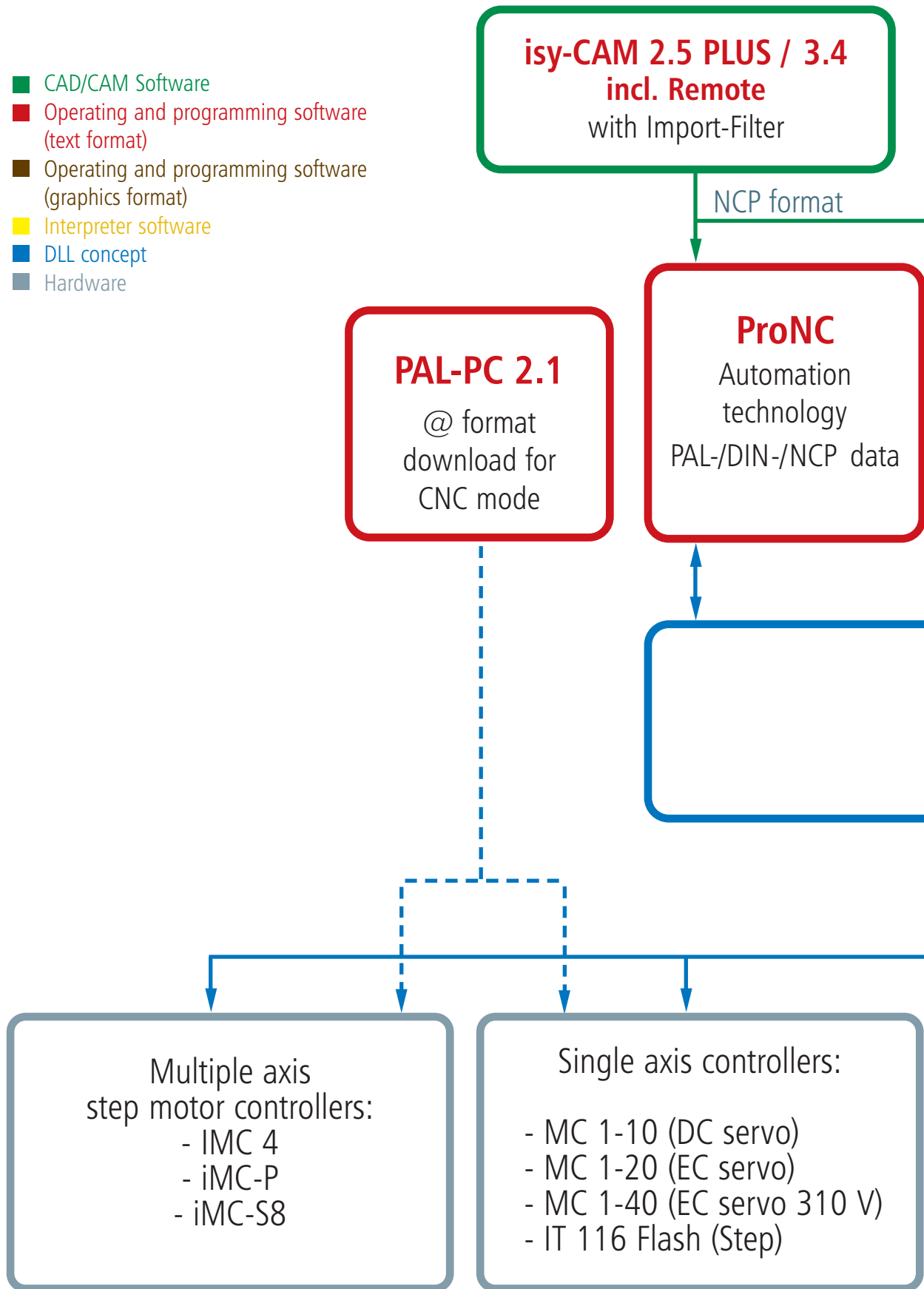

Software and controller organisation

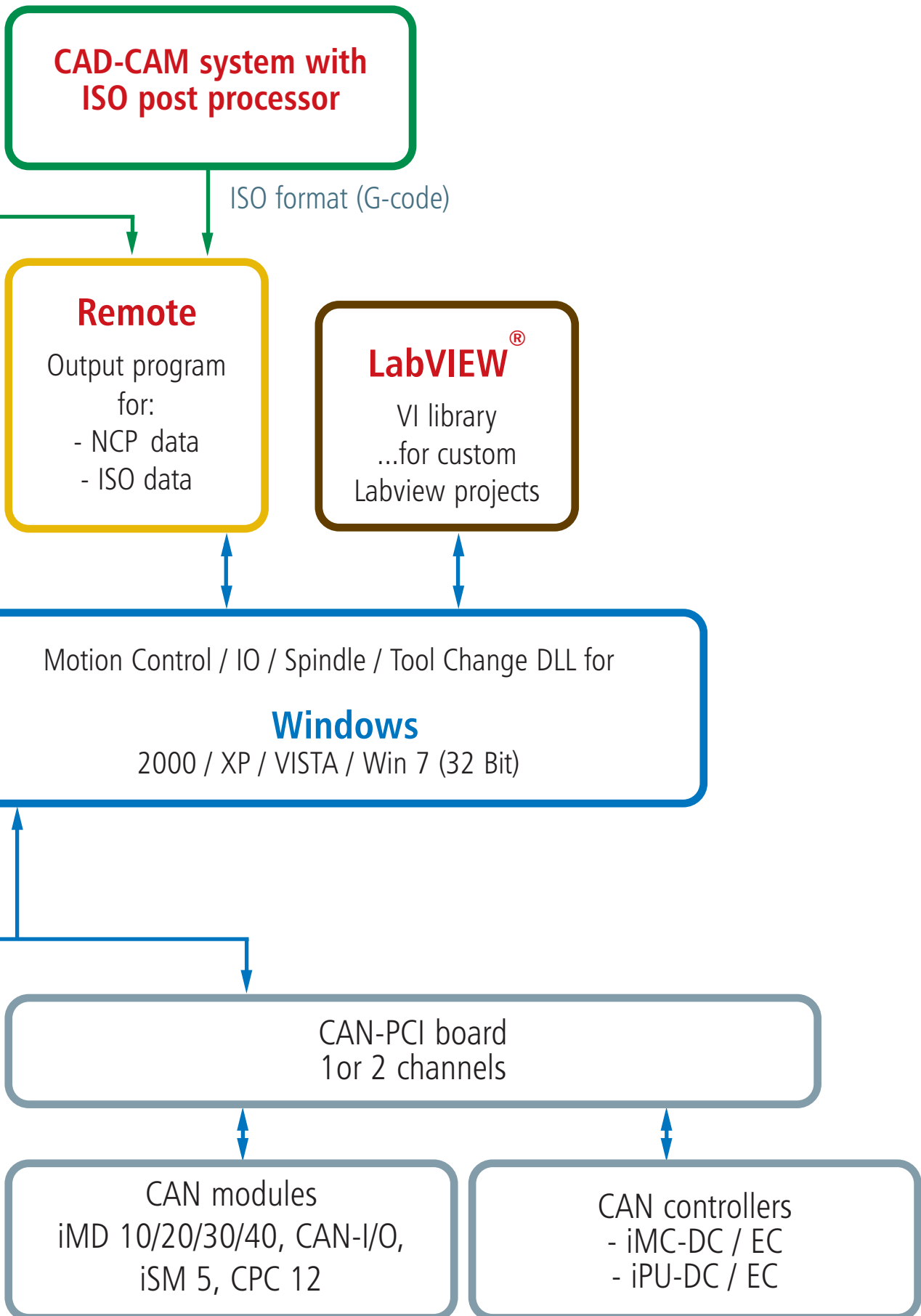

isy-CAM 2.5 PLUS

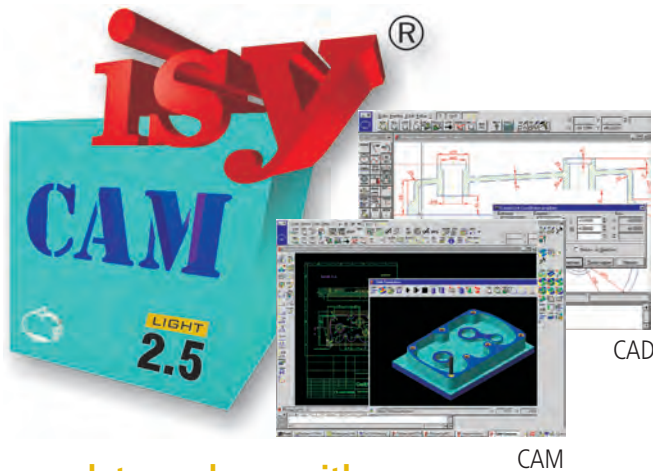

a complete package with:

- 2D-CAD/Design
- 2.5D-CAM up to 3+1 axes
- Integrated machine controller
- Service

General

With **isy-CAM 2.5 PLUS** the customer is provided with a Windows®-based CAD/CAM package. It provides a comprehensive solution from design to production with CNC machines.

The software package provided is ideal for entry into the CAD/CAM world. Operation is "windows-like", via graphic menus and dialogue boxes.

The **CAD component** includes all necessary features for design in the 2D area. With the **CAM component**, processing data for the machine controller can be generated simply and quickly - directly from the design data. This processing data can then be output directly with the integrated operating and output software Remote to the CNC machine or controller.

Post-processor features

- Tool list with selection and instructions for the tool geometry
- Immersion versions/start-up strategy
- Automatic residual material treatment
- Clockwise/reverse running
- Measurement/undersize machining
- Calculation tolerances
- Tool track separation
- Any setting of the processing sequence for technology blocks
- Post-processor run to generate NCP data for 3 axes (X/Y/Z) or cylindrical jacket area with a 4th axis (spindle)

Ordering information

Part no.: **Z13-337030**
isy-CAM 2.5 PLUS

Part no.: **Z13-337030-0001**
Update isy-CAM 2.5 light to isy-CAM 2.5 PLUS

Part no.: **Z13-337030-1000**
Second licence on isy-CAM 2.5 PLUS

Features

- freely definable line types and colours
- integrated online help, configurable interface
- parallel and independent working on several drawings
- Geometric element such as points, lines, ellipses, circles, curves (polygons, splines, Bezier curves, NURBS), polygons and many more.
- direct use of Windows scripts
- professional counting and text preparation features
- Hatching, freely definable hatching types
- automatic arrangement and alignment features
- Sketching outlines and changing them interactively
- numeric input options for absolute, relative and polar coordinates
- Import: DXF, HPGL, AI, EPS, TIFF, BMP, NC, NCP
- Export: DXF, HPGL, AI, WMF, EMF, TIFF, JPG, BMP
- extensive DIN/ISO-compliant measuring and dimensioning features
- Trim, separate and drag curves, Conversions of various geometry types
- Geometry manipulation by moving and copying as translation, rotation, scaling, mirror imaging
- intelligent object snapping
- optimum checking of the computed NCP data through integrated online simulation of the tool tracks
- Generation of processing data for all typical 2D and 2.5D production tasks
- Option: 3D version to order

Remote

Control software for Windows

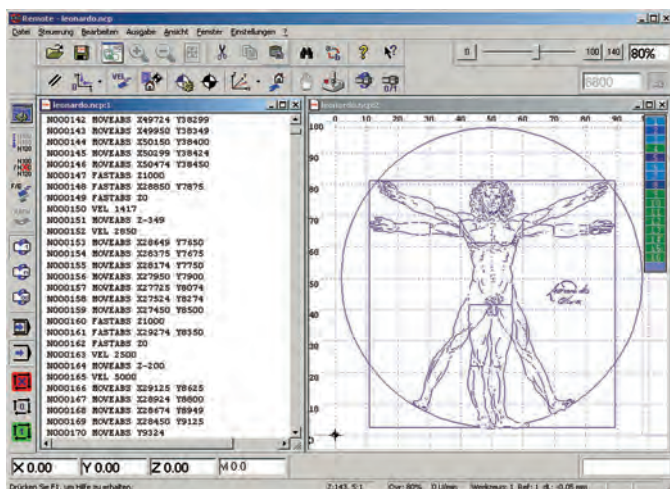

General

Remote is a universal control program for outputting files for machining methods milling, drilling, adhesive bonding, engraving, applying and water jet cutting or laser cutting/welding.

Supported file formats are the isel-specific NCP format (ASCII file with machining data generated by a CAM post-processor, the isel-specific CNC format (ASCII files in an expanded format for universal use in the process automation area, generated by ProNC) and the G-code format to DIN 66025.

Remote is used first and foremost for controlling CNC machines operating different tasks and processes, which is why flexibility is a key feature of the program. A large choice of options allows easy adaptation to current requirements in each case.

Features

- Support for digital joysticks
- "Fast file selection" control panel for serial production
- Milling/multiple output with movements
- Graphic depiction of the processing file with zero point and dimensions

isel-NCP, DIN66025/G-code file formats

- Linear and circular interpolation, helical interpolation, drilling cycles
- Access to digital and analogue inputs and outputs
- When using a CAN controller: "On-the-fly" input/output (without stopping the movement) for metering applications
- Message window, messages in the status line, time delay, input of variable values
- Definition and use of machine positions (tool zero point, park position, home position, etc.)

Additional features for the isel-CNC file format (ProNC output format)

- Repeating loops, counting loops, unconditional and conditional branches
- Arithmetic and trigonometric functions
- Sub-program systems
- Real and symbol chain variables
- Loading and storing process variables
- Access to user-specific expansions, option to call up user software

Ordering information

Part no.: **Z12-334500**

Remote - software for CAN-CNC controllers (Windows)

Features

- runs with Windows operating systems (Windows 2000, XP, Vista)
- compatible with previous software versions
- Processing of DIN66025 (G-code) file formats, NCP or CNC
- immediate processing without conversion, File translation or conversion
- integrated text editor with numerous features for rapid corrections to the present NC program
- Use of up to 6 interpolating axes (Cartesian coordinates system and 3 auxiliary axes)
- Look-ahead track processing with CAN controller
- Managing a milling spindle
- 2 I/O units can be used (max. 64 inputs, 64 outputs)
- Signalling inputs and outputs for process synchronisation
- manual axis movement with joystick, keyboard and mouse
- incremental processing and system monitoring for commissioning
- Configurable interface for user-friendly operation, serial production, handshake with master PLC, etc.
- Control panel for movement control, input/output, spindle and tool change with buttons
- Control panel for max. 6 handling axes independently of the interpolating axes available in various languages (German, English, French, Magyar)

PAL-PC

Process automation software for Windows

free updates

under
www.isel-germany.de

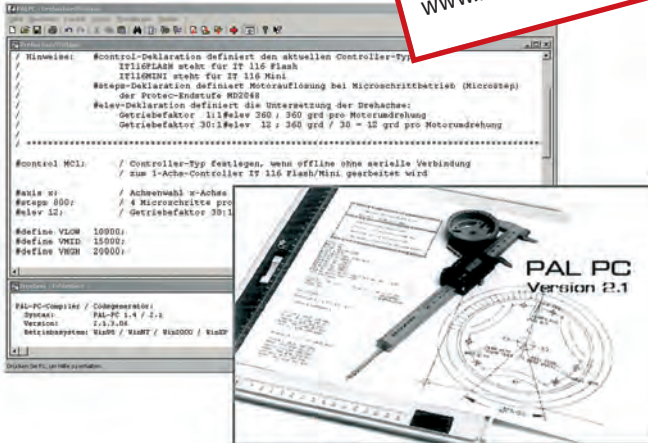

General

PAL-PC enables rapid, easy and low-cost implementation of automation projects such as handling systems, drilling machines, clamping devices, test and measurement systems, machines for individual and serial processing and much more....

PAL-PC is a modern program development environment for CNC step motor controllers and CNC machines

PAL-PC uses **memory operation** (CNC mode) for the target controller. PAL-PC produces automation solutions in which the controller works in standalone mode, i.e. independent of a control computer.

PAL-PC runs with Windows 2000, XP and Vista operating systems.

Features

- Path commands for relative and absolute positioning
- Carry out movement until event occurs at an input
- Teach-in-programming (linear)
- Linear 2D interpolation, switchable to 3D interpolation
- Circular interpolation
- Input signal analysis for process control
- Loops for repeating of instruction blocks
- Unconditional and conditional branches
- Analysis of the program selection unit
- Output of messages to a display
- Sending and receiving synchronisation marks
- Additional aids for automated processing of typical tasks

Ordering information

Part no.: **Z11-331810**

PAL-PC - software for CAN-CNC controllers (Windows)

Features

- compatible with previous versions (PAL-PC programs, which were produced with an earlier release of PAL-PC, can be used without adaptation)
- Programming to isel-PAL or DIN66025: In addition to the PAL format, users who know programming to DIN66025, can also produce their PAL-PC applications with corresponding G-code commands.
- Integrated editor: fast and convenient editing of source texts, editor features such as "Search", "Replace", "Copy" and "Insert" automated code generation, multiple Undo/Redo for efficient programming
- PAL-PC can (depending of the type of controller used) control controllers with up to 4 axes
- Terminal for direct communication with the controller
- Downloading of externally generated CNC programs
- Automatic calculation of type and data transfer rate of the connected controller
- Display of compiler errors and navigating to an error in the source code
- Command rapid overview with optional insertion into the program
- Teach-in-programming with keyboard or mouse
- Acceptance in the editor of target positions as formatted source code
- Live status display at the inputs
- Setting outputs during program generation
- available in German and English

ProNC

Process automation software for Windows

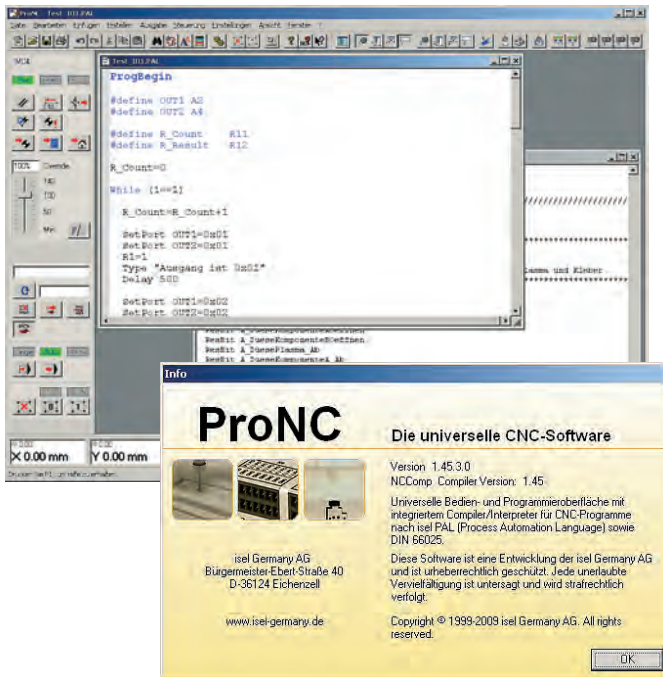

General

The basis of any automation solution is a powerful software that enables implementation of practical solutions for existing tasks quickly and conveniently. In these cases, the operating and programming interface ProNC provides an ideal solution.

- ProNC** runs with the Windows 2000, XP and Vista operating systems.
- ProNC** is available for a variety of control systems and controllers from isel
- ProNC** applications can be produced to isel-PAL or DIN66025

ProNC is outstandingly suited to automation solutions in the milling, drilling, metering, installation, handling, loading and quality control fields, in which application programs are produced mainly in text format, using teach-in-features and the integration of contour data sets (e. g. NCP format).

Features

- Path commands for relative and absolute positioning of the interpolating axes
- Programming of additional axes in handling mode
- Circular interpolation, helical interpolation, drilling cycles
- Repeating loops, counting loops, unconditional and conditional branches
- various mathematical and trigonometric functions
- Sub-program systems, symbolic variables
- Real and symbol chain variables
- Message window, messages in the status line
- Loading and storing process variables
- Access to digital and analogue inputs and outputs
- "On-the-fly" input/output (without stopping the movement) for metering applications
- Access to user-specific extension DLLs
- convenient support for debugging (interruption points, monitoring of status and variable)

Ordering information

Part no.: **Z11-333500**

ProNC - software for CAN-CNC controllers (Windows)

Features

- Programming to DIN66025 (G-codes) or isel-PAL
- compatible with previous software versions (ProDIN, ProPAL)
- integrated text editor with numerous features for rapid and efficient source code processing
- Import of geometric data (NCP, e.g. from isy-CAD/CAM)
- Use of up to 6 interpolating and up to 6 handling axes (with CAN controller)
- Look-ahead track processing with CAN controller
- up to 4 spindle motors can be used
- up to 4 I/O units can be used (max. 64 inputs, 64 outputs)
- Signalling inputs and outputs for process synchronisation
- Teach-in-with joystick, keyboard and mouse
- Offline programming with simulation modules
- incremental processing, hold points and system monitoring for commissioning
- individually expandable with software libraries
- Control panels for movement control, input/output, spindle and tool change with buttons
- Control panel for max. 6 handling axes independent of the interpolating axes
- available in German and English

Training courses and application solutions to order.