A Die Sets

B Precision Ground Plates and Flat Bars

C Lifting and Clamping Devices

D Guide Elements

E Ground Precision Components

Punches and Matrixes,
Pins, Gauge Pins

F Springs

G Elastomer-Bars, -Sheets, -Sections

H FIBRO Chemical Tooling Aids

J Peripheral Equipment

K Cam Units

L Standard Parts for Mould Making



Ground Precision Components

Ground Precision Components

FIBRO Precision Components cover a very wide range of materials, shapes and sizes and thus permit virtually unrestricted selection even to highly individual requirements.

At Hassmersheim and also abroad, stock levels of Precision Components reach seven-digit figures. It is therefore quite likely that your particular choice will be available for immediate delivery. Should this not be the case then our flexible batch production schedules will ensure that delays are kept to a minimum.

Batch production in our interpretation not only spells prompt delivery but also exceptional quality. Starting with the arrival inspection of raw materials, every single manufacturing operation on FIBRO Precision Components is followed by a quality check. Lastly, an uncompromising final inspection of each and every part guarantees that the trade mark FIBRO is and remains synonymous with Quality.















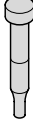

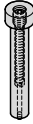

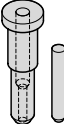
In view of the fact that a large portion of the Precision Components programme consists of punches and matrices, the importance of alignment in the operational die must be emphasized. Unless this requirement can be met to a high degree of accuracy, even the finest efforts in design and in the toolroom must fail! Die alignment ultimately depends on the guides – FIBRO Die Sets and Guide Elements were developed and are made with this postulate in mind.

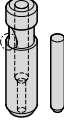
Tool life, production cost and work quality are to a large extent a function of tooling material selection versus strip stock characteristics and ancillary process conditions. A judicious choice from the wide range of materials for our punches and matrices will be facilitated by the orientation guide in this catalogue. Listing the principal characteristics of each material together with selection criteria, it is intended to help customers make the right choice.







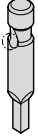

Our experienced tooling specialists will assist you with further detailed information.

In keeping with the basic tenet of our firm, every effort is made to ensure that design, performance potential and quality of FIBRO Precision Components keep well abreast with latest technological developments.

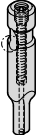
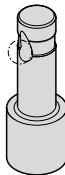
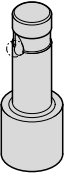
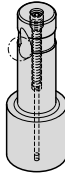
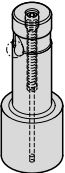









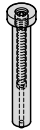









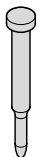
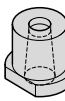

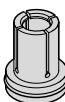







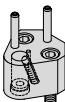





Contents

		Page			Page
	Description of Materials	E10-E11, E26		220. Precision Punches DIN 9844, Shape A	E21
	Assembly Guide Lines for Head Type Punches with round Points	E20			
	222. Precision Punches DIN 9861, Shape DA	E12		221. Precision Punches DIN 9844, Shape B	E21
	223. Precision Punches DIN 9861 Shape D/ISO 6752	E13			
	224. Precision Punches DIN 9861, Shape CA+C	E14		266. Precision Punches, similar to VDI 3374	E23
	225.				
	274. Precision Punches, similar to 275. DIN 9861 Shape CA+C	E15		267. Precision Punches with Ejector Pin	E24
	232. Stepped Quill Punches – Conical Head VDI 3374	E16		268. Precision Punches with Ejector Pin, Stepped, Short Point	E25
	233. Head Type Quill Bush and Thrust Pin VDI 3374	E16		269. Precision Punches with Ejector Pin, Stepped, Long Point	E25
	234. Ball Lock Type Quill Bush and Thrust Pin VDI 3374	E16			
	2281. Round Precision Punches with tapered heads 30°, Shape D	E17		270. Carbide Punches – similar to DIN 9844 + DIN 9861, Shape A, Cylindrical Head – Straight	E27
	2291. Round Precision Punches with tapered heads 30°, Shape C	D17		271. Carbide Punches – similar to DIN 9844 + DIN 9861, Shape B, Cylindrical Head – Stepped	E27
	2284.3. Punch with tapered head, Shape D	E18- E19		272. Carbide Punches – similar to DIN 9844 + DIN 9861, Shape D, Conical Head – Straight	E27
	2284.00. Piloted counterbore for tapered- head punch			273. Carbide Punches – similar to DIN 9844 + DIN 9861, Shape C, Conical Head – Stepped	E27



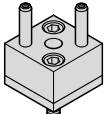

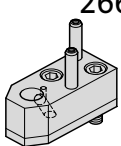



Contents

		Page			Page
	2202. Ball-Lock Punches blank, light duty	E32-E34		2703. Ball-Lock Punches blank with ejector pin, heavy duty	E49-E51
	2212. Ball-Lock Punches stepped, light duty			2713. Ball-Lock Punches stepped with ejector pin, heavy duty	
	2222.			2723.	
	2232.			2733.	
	2242.			2743.	
	2252.			2753.	
	2702. Ball-Lock Punches blank with ejector pin, light duty	E35-E37		2205. Ball-Lock Punches, punch larger than shaft, heavy duty	E52-E54
	2712. Ball-Lock Punches stepped with ejector pin, light duty			2215. Ball-Lock Punches, punch larger than shaft, heavy duty	
	2722.			2225.	
	2732.			2235.	
	2742.			2245.	
	2752.			2255.	
	2204. Ball-Lock Punches punch larger than shaft, light duty	E38-E40		2705. Ball-Lock Punches, punch larger than shaft, heavy duty with ejector pin	E55-E57
	2214. Ball-Lock Punches punch larger than shaft, light duty			2715. Ball-Lock Punches, punch larger than shaft, heavy duty with ejector pin	
	2224.			2725.	
	2234.			2735.	
	2244.			2745.	
	2254.			2755.	
	2704. Ball-Lock Punches, punch larger than shaft, light duty with ejector pin	E41-E43		2263. Ball-Lock Pilot Pins, with tapered tip, heavy duty	E58
	2714. Ball-Lock Punches, punch larger than shaft, light duty with ejector pin			2273. Ball-Lock Pilot Pins, with parabolic tip, heavy duty	E59
	2724.				
	2734.				
	2744.				
	2754.				
	2262. Ball-Lock Pilot Pins, with tapered tip, light duty	E44		2201. Precision Punches, Blank, ISO 8020	E64-E66
	2272. Ball-Lock Pilot Pins, with parabolic tip, light duty	E45		2211. Precision Punches, stepped, ISO 8020	
				2221.	
				2231.	
				2241.	
				2251.	
	2203. Ball-Lock Punches, blank, heavy duty	E46-E48			
	2213. Ball-Lock Punches, stepped, heavy duty				
	2223.				
	2233.				
	2243.				
	2253.				

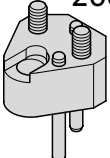
Contents

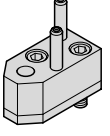
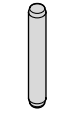
		Page			Page
	2701. Precision Punches, blanc, with ejector pin, ISO 8020	E67-E69		2602. Precision Matrixes without collar, cylindrical	E94
	2711. Precision Punches, stepped, with ejector pin, ISO 8020			2612. Precision Matrixes with collar, cylindrical	E94
	2721. Precision Punches, stepped, with ejector pin, ISO 8020				
	2731. Precision Punches, stepped, with ejector pin, ISO 8020				
	2741. Precision Punches, stepped, with ejector pin, ISO 8020				
	2751. Precision Punches, stepped, with ejector pin, ISO 8020				
	2261. Pilot Pins with tapered tip, ISO 8020	E70		2601. Precision Matrixes without collar, conical	E95
	2271. Pilot Pins with parabolic tip, ISO 8020	E71		2611. Precision Matrixes with collar, conical	E95
	2276. Pilot Units to Daimler Standard	E72		Standardised Special Shapes Punches/Precision Matrixes	E99-E101
	2606. Precision Matrixes without shoulder, cylindrical ISO 8977	E77-E81		2618. Dynamic Strippers	E104
	2616. Precision Matrixes without shoulder, cylindrical ISO 8977			2618.06. Matrixes with or without shoulder for Dynamic Strippers	E105-E106
	2626. Precision Matrixes without shoulder, cylindrical ISO 8977			2618.16. Matrixes with or without shoulder for Dynamic Strippers	
	2636. Precision Matrixes without shoulder, cylindrical ISO 8977			2618.07. Matrixes with or without shoulder for Dynamic Strippers	
	2646. Precision Matrixes without shoulder, cylindrical ISO 8977			2618.17. Matrixes with or without shoulder for Dynamic Strippers	
	2656. Precision Matrixes without shoulder, cylindrical ISO 8977				
	2607. Precision Matrixes with shoulder, cylindrical, ISO 8977	E83-E87		2664.05. Triangle Precision Retainers for Ball-Lock Punches, light duty/heavy duty	E108-E110
	2617. Precision Matrixes with shoulder, cylindrical, ISO 8977			2664.06. Triangle Precision Retainers for Ball-Lock Punches, light duty/heavy duty	
	2627. Precision Matrixes with shoulder, cylindrical, ISO 8977			2664.07. Triangle Precision Retainers for Ball-Lock Punches, light duty/heavy duty	
	2637. Precision Matrixes with shoulder, cylindrical, ISO 8977			2664.10. Triangle Precision Retainers for Ball-Lock Punches, light duty/heavy duty	
	2647. Precision Matrixes with shoulder, cylindrical, ISO 8977			2664.08. Triangle Precision Retainers for Ball-Lock Punches, light duty/heavy duty	
	2657. Precision Matrixes with shoulder, cylindrical, ISO 8977			2664.09. Triangle Precision Retainers for Ball-Lock Punches, light duty/heavy duty	
	2605. Matrixes without shoulder, automotive standard	E88-E90		Accessories for Precision Retainers, triangular, for Ball-Lock Punches	E111
	2615. Matrixes without shoulder, automotive standard				
	2625. Matrixes without shoulder, automotive standard				
	2635. Matrixes without shoulder, automotive standard				
	2645. Matrixes without shoulder, automotive standard				
	2655. Matrixes without shoulder, automotive standard				
	262. Precision Guide Bushes for Punches DIN 9845, Shape C	E92		2661.07. Square Precision Retainers for Ball-Lock Punches, light duty	E112
	2621. Precision Guide Bushes for Punches ISO 8978	E92		2661.08. Square Precision Retainers for Ball-Lock Punches, light duty	
	260. Precision Matrixes without collar DIN 9845, Shape A	E93		2662.05. Rectangular Precision Retainers for Ball-Lock Punches, light duty	E113
	261. Precision Matrixes with collar, DIN 9845, Shape B	E93			

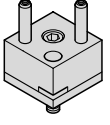
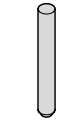
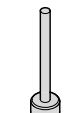
Contents

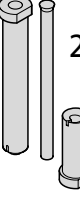
	Page		Page
2668.2. ACCU-LOCK Fixture Device for 2668.3. Ball-Lock Punches, light and heavy duty	E114	High-Precision Special Parts	E128- E129
2664.02. Triangle Precision Retainers for round Punches, ISO 8020	E116	 230. Precision Punches, Square/ Rectangular, without Head	E130
2664.04. for profile Punches, ISO 8020	E117	 231. Precision Punches, Square/ Rectangular, with Hot Upset- Forged Head	E130
 Accessories for Precision Retainers, triangular, for Punches, ISO 8020	E118	236.1. Precision Dowel Pins (Parallel) with Internal Extracting Thread, similar to DIN EN ISO 8735/ ISO 8735	E131- E132
2661.01. Square Precision Retainers for 2661.02. Punches to ISO 8020	E119	 236.001. Dowel Pin Extractor FIBROZIPP	
2662.01. Rectangular Precision Retainers 2662.02. for Punches to ISO 8020	E122	 265.1. High-Precision Liner Bushes for 2650.1. Dowel Pins, for bonding for push fit	E133
 2661.03. Square Precision Retainers for 2661.04. round Punches to VDI 3374	E123	 235.1. Precision Dowel Pins (Parallel) 2351.1. similar to DIN EN ISO 8734/ ISO 8734	E134- E135
2661.05. Square Precision Retainers for 2661.06. profile Punches to VDI 3374	E124	 276. Precision Drill Bushes Shape A, DIN 172, with collar	E137
2662.03. Rectangular Precision Retainers 2662.04. for Punches to VDI 3374	E126	 277. Precision Drill Bushes Shape A, DIN 179, without collar	E137
 2431.7. Stripping unit	E127	 240. High-Precision Gauge Pins DIN 2269, Accessories: Wooden Boxes for Gauge Pins, Gauge Pin Holders	E138- E139
2667. Stripping unit mountings	E140	 240.11. High Precision Gauge Pins with 240.22. Handle	E140
	E140	 240.31. High Precision Gauge Pins – 240.32. Boxed Sets	E140
 2282.01. Punching and embossing units for punched holes	E141		E141

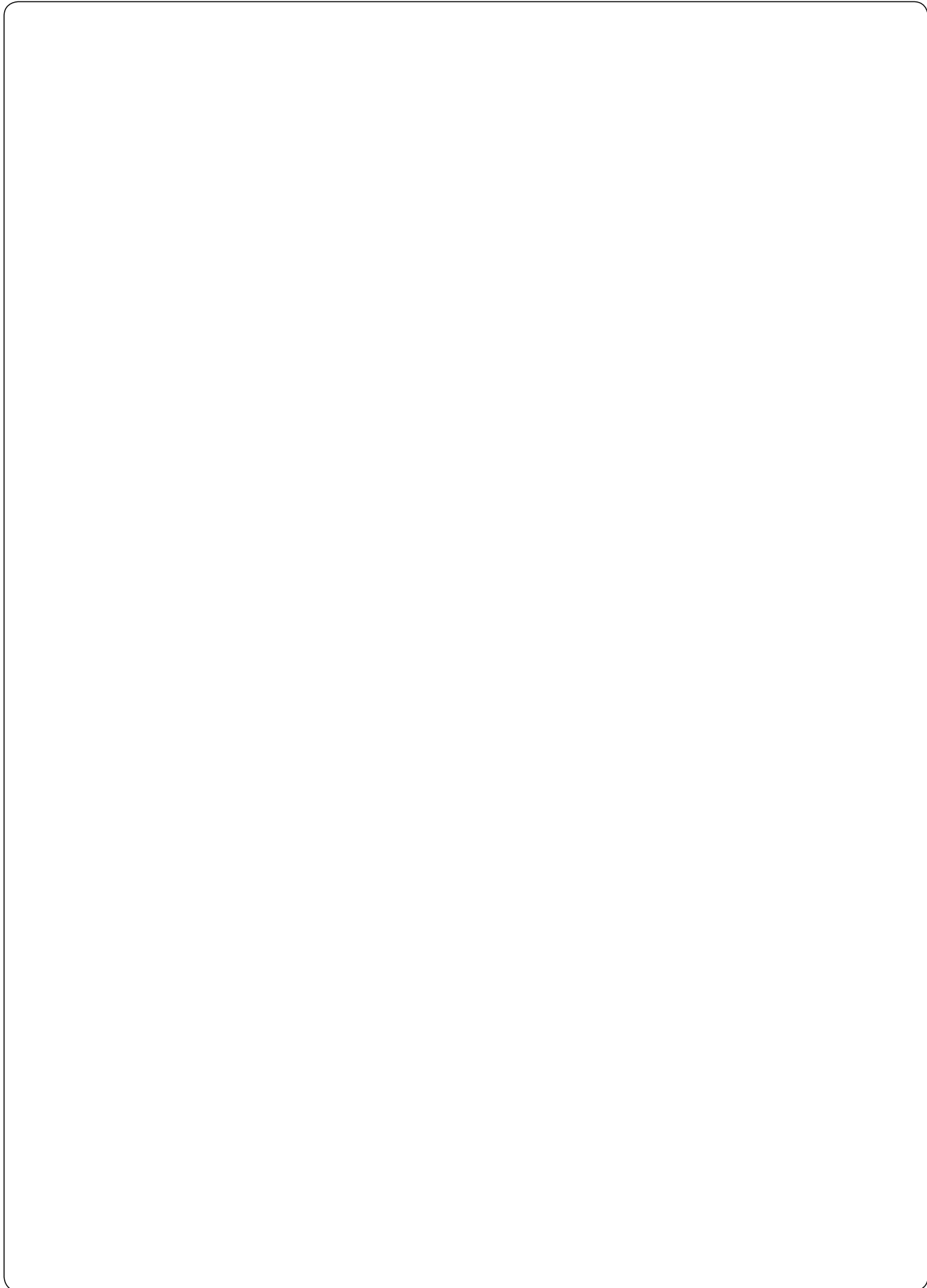

Comparative Graphs

Compressive Strength (0,2% Proof Stress)

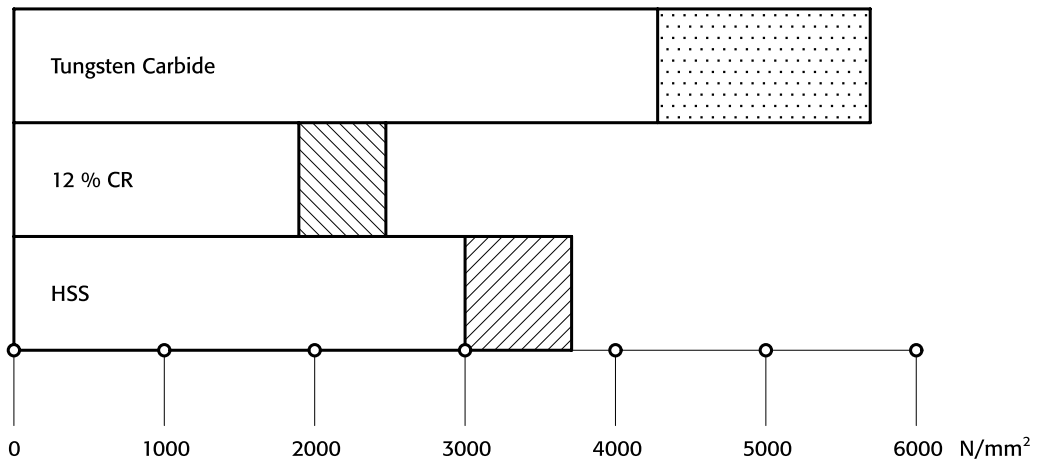

Flexural Strength

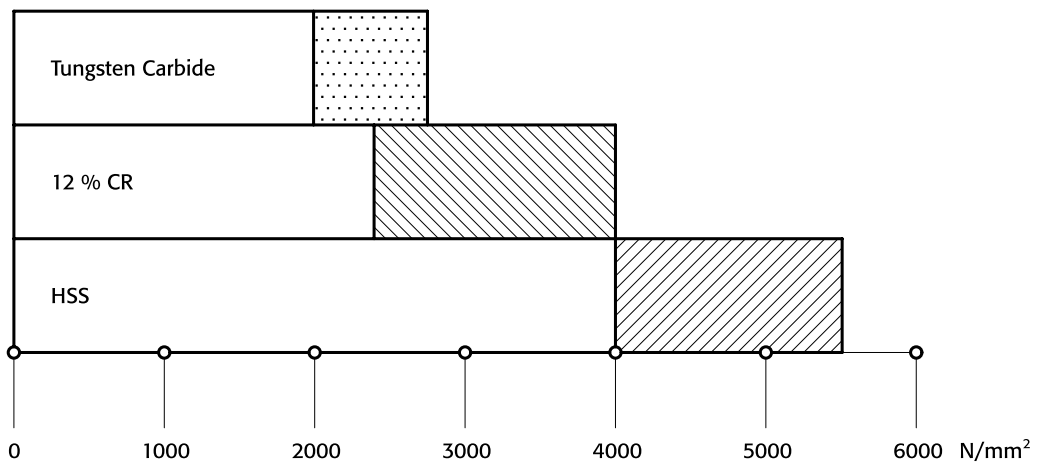

HV 30 - Hardness

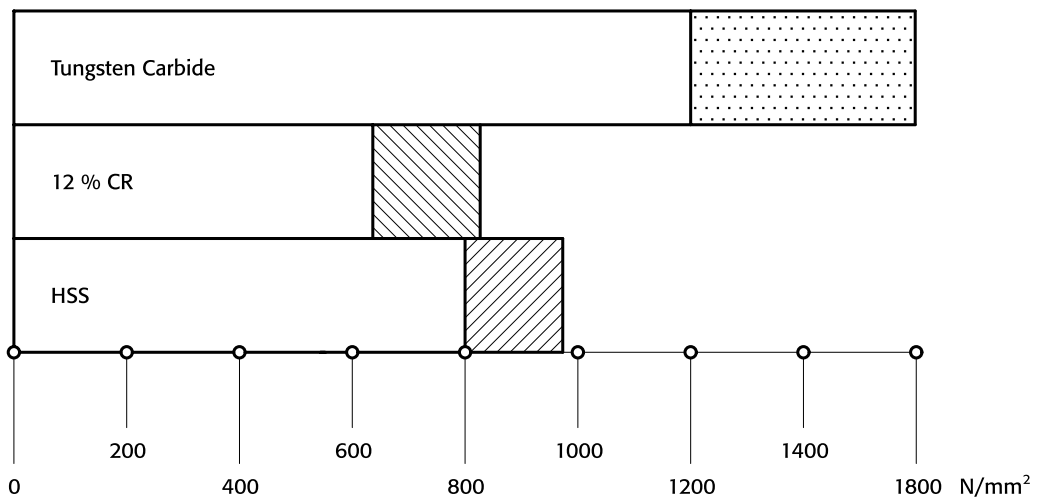

FIBRO Punches and Matrixes – Description of Materials

<p>WS</p> <p>Characteristics: Application Field:</p>	<p>= Alloy Tool Steel</p> <p>Material No 1.2210, 1.2516, 1.2842 or similar.</p> <p>Hard and tough tool steel, medium wear resistance.</p> <p>Piercing/blanking dies for mild steel, low carbon steels, non-ferrous metals, plastics, paper.</p>	<p>WS = material code number = "1"</p> <p>e.g. Order No = 239.1 ...</p>
<p>HWS</p> <p>Characteristics: Application Field:</p>	<p>= High Carbon – High Chrome Tool Steel (12% Cr)</p> <p>Material No 1.2436, 1.2379 or similar.</p> <p>High resistance to wear.</p> <p>Piercing/blanking dies of all types, trim dies, for all carbon steels, alloy steels, non-ferrous metals, plastics, paper.</p>	<p>HWS = material code number = "2"</p> <p>e.g. Order No = 260.2 ...</p>
<p>HSS</p> <p>Characteristics: Application Field:</p>	<p>= High Speed Steel</p> <p>Material No 1.3343 or similar.</p> <p>High wear resistance; high tempering curve permits certain surface treatments.</p> <p>Piercing/blanking dies of all types – for tough materials e.g. spring steel, lamination steels, and abrasive papers as well as plastics.</p>	<p>HSS = material code number = "3"</p> <p>e.g. Order No = 220.3 ...</p>
<p>ASP 23 ASP 2023</p> <p>Characteristics: Application Field:</p>	<p>= High Speed Steel on Powder-Metallurgic Basis</p> <p>High wear resistance – greater toughness due to excellent homogeneity.</p> <p>Same as HSS.</p>	<p>ASP 23 ASP 2023 = material code number = "6"</p> <p>e.g. Order No = 223.6 ...</p>
<p>HST</p> <p>Characteristics: Application Field:</p>	<p>= High Speed Steel, Nitrided</p> <p>High wear resistance – reduced galling tendency on account of nitrides infused into top layer of material.</p> <p>Piercing/blanking dies of all types – for very hard and abrasive materials.</p>	<p>HST = material code number = "4"</p> <p>e.g. Order No = 223.4 ...</p>
<p>FT</p> <p>Characteristics: Application Field:</p>	<p>= Ferro-Tic (Ferro Titanit)</p> <p>Between those of HSS and hard metals (tungsten carbides); machinable in the supplied state – hardness conferred by heat treatment.</p> <p>Fine blanking and progression/lamination dies for large quantities of parts from abrasive, hard materials, also silicon steels and stainless steels.</p>	<p>FT special manufacture – on request –</p>

HZ = Hard-coated Tooling Components for High-Performance

HZC Composite Vapour Deposition (CVD) **TIC-TIN** Coating

Carrier Materials: HSS Material No 1.3207 and 1.3343 etc.
HCHC Material No 1.2379 and 1.2436 etc.

Properties: The titanium carbide substrate provides a pressure-resistant bond with the carrier metal, while the outer layer of titanium nitride offers the well-known advantages of optimum tribologic behaviour in contact with the stamping stock. By virtue of its outstanding wear resistance, the TIN-layer largely eliminates seizing and cold welding problems in stamping.
Surface Hardness: approx. 3500 HV 0,05
Coating Thickness: 5 to 8 µm approx.

Applications: All tooling components subject to high demands on wear resistance and performance, especially punches in progression/combination tools, as well as cold extrusion punches etc.
Owing to distorsion problems, TIC-TIN is not recommended for parts with a length/thickness ratio than 20:1.

TIC-TIN = material code number = "5"
e. g. Order No = 223.5. ...

HZN Titanium Nitride Coating **TIN-PVD** (physical vapour deposition).

Carrier Material: HSS Material No 1.3207 and 1.3343 etc.
HCHC Material No 1.2379
(HCHC-steels are of conditional suitability)

Properties: The TIN-coating offers excellent frictional characteristics but its compressive strength remains inferior to TIC-TIN deposits. The TIN-deposition process can be applied to partial, selected areas of the tooling component.
Surface Hardness: approx. 2300 HV 0,05
Coating Thickness: 2–4 µm < Ø 20 = 1,5 µm ± 20 %

Applications: Tooling for thin stamping stock such as cold rolled spring steel, zinc-galvanized sheet and strip, copper-beryllium bronze, german silver, and solenoid lamination steels.
Note that the ratio stock thickness to punch point diameter should not exceed 1:3.

TIN = material code number = "0"
e. g. Order No = 223.0. ...

HM = Tungsten Carbide

Characteristics: Hard-sintered carbide on WC-basis and of recognized properties; produced by powder-metallurgic processes, FIBRO's exclusively used HIP-densified carbide exhibits much enhanced flexural strength and reduced residual porosity.

Application Field: Die components for highest performance and very large stamping volumes – for altogether ultimate demands on tool life.

HM = material code number = "9"
e. g. Order No = 270.9. ...

NWA = Hot-Work Tool Steel – Suitable for Nitriding

Material No 1.2344 or similar.

Characteristics: Chrome-Molybdenum-Vanadium hot working die steel; core strength: > 1400 N/mm²; temperature resistant up to 650°C; surface hardness (nitrided) ≥ 950 HV 0,3.

Application Field: Ejector pins for pressure diecasting, injection- and compression moulding processes, and generally for work at elevated temperatures.

NWA = material code number = "8"
e. g. Order No = 237.8. ...

Precision Punches DIN 9861
Shape DA

222.

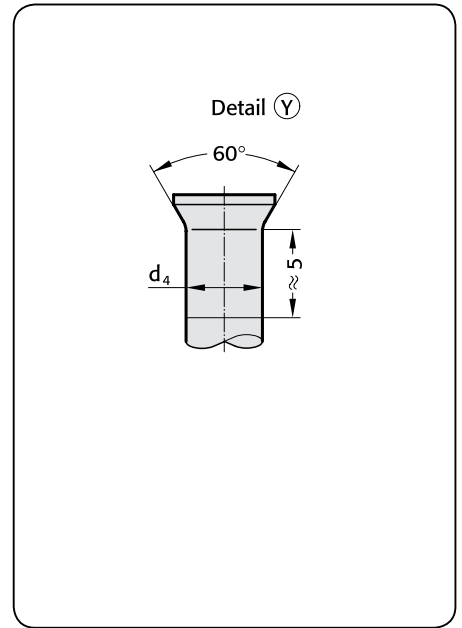
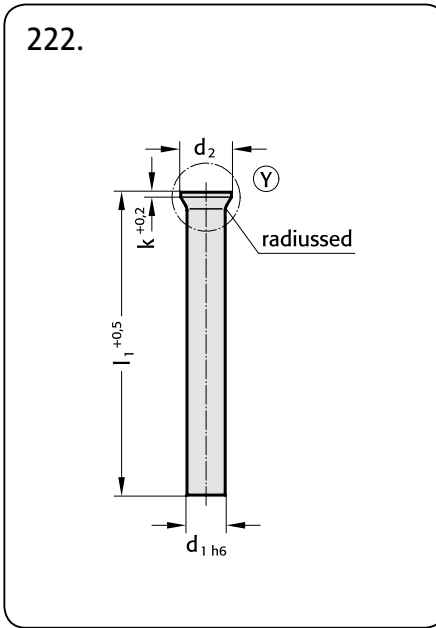

Material:
Type DA – Execution:
Shank precision ground.
Head hot upset-forged and tempered. Residual upset bulge below head normally much smaller than permissible acc. to DIN 9861.

Note:
Punches are also available without head

Ordering Code (example):

Punch	=	222.
Material HSS	=	3.
d ₁ = Ø 6,30 mm	=	0630.
l ₁ = 71 mm	=	071
Order No	=	222.3.0630.071

Material:

HZ – TIN (HSS)		222.0.
Order No:		2300 HV 0,05
Hardness:	Surface	52±3 HRC
	Head	
HSS		222.3.
Order No:		64±2 HRC
Hardness:	Shank	52±3 HRC
	Head	
HST		222.4.
Order No:		≧ 950 HV 0,3
Hardness:	Surface	52±3 HRC
	Head	

Description of FIBRO materials for die components:
pages E 10–E 11.

222. diameter steps						
d ₁	d ₁	d ₂	d ₄	k		l ₁
0,50	0,05	0,9	d ₁ ^{+0,02}	0,2		
0,55		1,0				
0,60		1,1				
0,65		1,2				
0,70 + 0,75		1,3				
0,80 + 0,85		1,4		0,4		
0,90 + 0,95		1,6				
1,0 + 1,1	0,1	1,8	d ₁ ^{+0,03}	0,5		
1,2 + 1,3		2,0				
1,4 + 1,5		2,2				
1,6 + 1,7		2,5				
1,8 + 1,9		2,8				
2,0		3,0				
2,1 + 2,2		3,2				
2,3 – 2,5		3,5				
2,6 – 2,9		4,0				
3,0 – 3,4		4,5				
3,5 – 3,9		5,0				
4,0 – 4,4		5,5				

stock lengths: 71, 80, 100 mm.
other lengths and diameters on request!

222. diameter steps						
d ₁	d ₁	d ₂	d ₄	k		l ₁
4,5 – 4,9	0,1	6,0	d ₁ ^{+0,03}	0,5		
5,0 – 5,4		6,5				
5,5 – 5,9		7,0				
6,0 – 6,4		8,0				
6,5 + 7,0	0,5	9,0		1,0		
7,5 + 8,0		10,0				
8,5 + 9,0		11,0				
9,5 + 10,0		12,0				
10,5 + 11,0		13,0				
11,5 + 12,0		14,0				
12,5 + 13,0		15,0				
13,5 + 14,0		16,0		1,5		
14,5 + 15,0		17,0				
15,5 + 16,0		18,0				

stock lengths: 71, 80, 100 mm.
other lengths and diameters on request!

223.

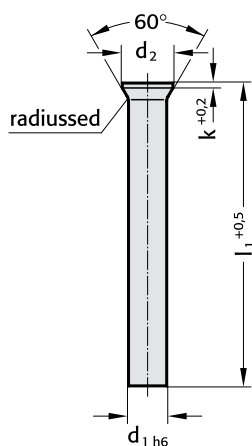

Material:

HSS		
Order No:		223.3.
Hardness:	Shank	64±2 HRC
	Head	52±3 HRC
HST		
Order No:		223.4.
Hardness:	Surface	≥ 950 HV 0,3
	Head	52±3 HRC
HZ – TIN (HSS)		
Order No:		223.0.
Hardness:	Surface	2300 HV 0,05
	Head	52±3 HRC
ASP 23–ASP 2023		
Order No:		223.6.
Hardness:	Shank	64±2 HRC
	Head	52±3 HRC

Description of FIBRO materials for die components:
pages E 10–E 11.

Type D – Execution:

Head hot upset-forged and tempered.
Shank and head subsequently precision plunge-ground for perfect concentricity and full interchangeability with replacement punches.

Ordering Code (example):

Punch	=	223.
Material HSS	=	3.
d ₁ = Ø 16,5 mm	=	1650.
l ₁ = 80 mm	=	080
Order No	=	223.3.1650.080

223.	diameter steps				l ₁
	d ₁	d ₂	k		
0,50	0,05	0,9	0,2		
0,55		1,0			
0,60		1,1			
0,65		1,2			
0,70 +0,75		1,3			
0,80 +0,85		1,4	0,4		
0,90 +0,95		1,6			
1,0 +1,1	0,1	1,8	0,5		
1,2 +1,3		2,0			
1,4 +1,5		2,2			
1,6 +1,7		2,5			
1,8 +1,9		2,8			
2,0		3,0			
2,1 +2,2		3,2			
2,3 –2,5		3,5			
2,6 –2,9		4,0			
3,0 –3,4		4,5			
3,5 –3,9		5,0			
4,0 –4,4		5,5			
4,5 –4,9	0,1	6,0			
5,0 –5,4		6,5			
5,5 –5,9		7,0			

stock lengths: 71, 80, 100 mm.
other lengths and diameters on request!

223.	diameter steps				l ₁
	d ₁ h6	d ₂	k		
6,0 – 6,4	0,1	8,0	0,5		
6,5 + 7,0	0,5	9,0	1,0		
7,5 + 8,0		10,0			
8,5 + 9,0		11,0			
9,5 +10,0		12,0			
10,5 +11,0		13,0			
11,5 +12,0		14,0			
12,5 +13,0		15,0			
13,5 +14,0		16,0	1,5		
14,5 +15,0		17,0			
15,5 +16,0		18,0			
16,5 +17,0		19,0			
17,5 +18,0		20,0			
18,5 +19,0		21,0			
19,5 +20,0		22,0			

stock lengths: 71, 80, 100 mm.
other lengths and diameters on request!

**Precision Punches DIN 9861
Shape CA+C**

224.
225.

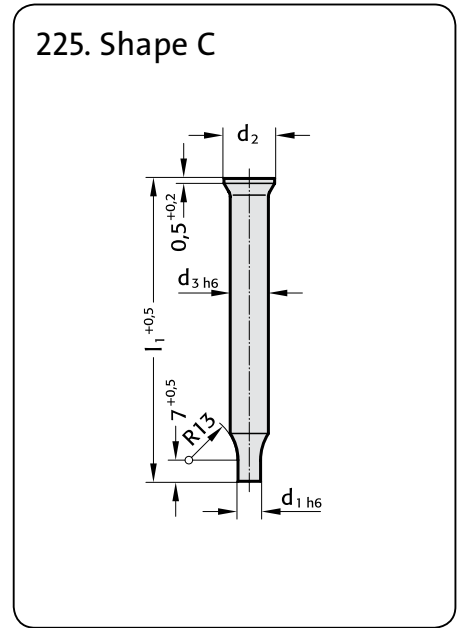
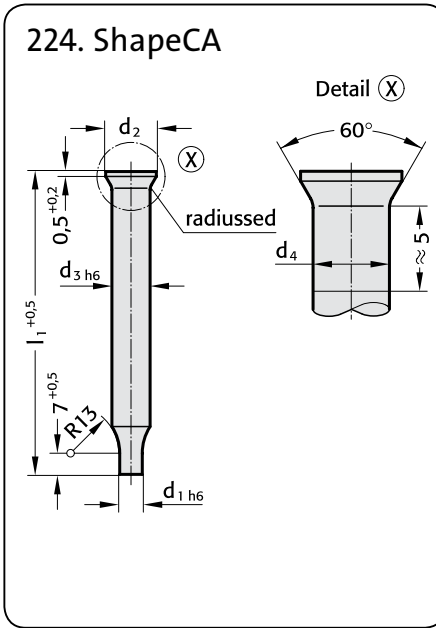
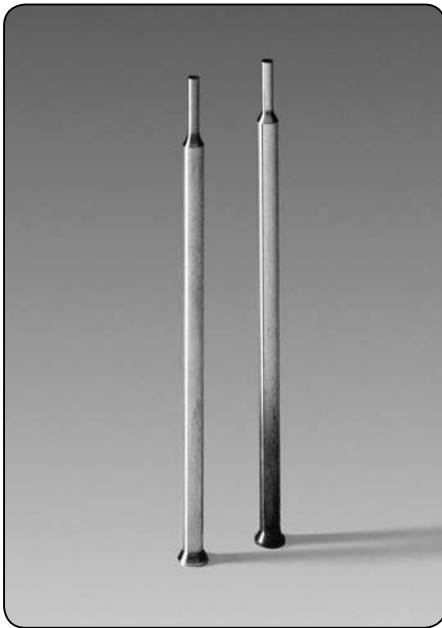

Executions:
 Shape CA
 Shank precision ground, head subsequently hot upset-forged and tempered; residual upset-buge below head normally much smaller than permissible acc. to DIN 9861.
 Shape C
 Head hot upset-forged and tempered.
 Shank and head subsequently precision plunge-ground for perfect concentricity and full interchangeability with replacement punches.

Ordering Code (example):

Punch C	=	225.
Material HSS	=	3.
d ₁ = ∅ 2,30 mm	=	0230.
l ₁ = 71 mm	=	071
Order No	=	225.3.0230.071

Material:

HZ – TIN (HSS)	Form CA = 224.0.
Order No:	Form C = 225.0.
Hardness: Surface Head	2300 HV 0,05 52±3 HRC
HSS	Form CA = 224.3.
Order No:	Form C = 225.3.
Hardness: Shank Head	64±2 HRC 52±3 HRC
HST	Form C = 225.4.
Order No:	≥ 950 HV 0,3
Hardness: Surface Head	52±3 HRC
ASP 23–ASP 2023	Form C = 225.6.
Order No:	64±2 HRC
Hardness: Shank Head	52±3 HRC

Description of FIBRO materials for die components:
pages E 10 – E 11.

224.

d ₁	diameter steps		d ₂	d ₃	d ₄	l ₁
0,1–0,45	0,05	3	2	d ₃ ^{+0,03}		stock lengths: 71 mm. other lengths and diameters on request.
0,50						
0,55						
0,60						
0,65						
0,70 + 0,75						
0,80 + 0,85						
0,90 + 0,95						
1,00 – 1,10						
1,15 – 1,30						
1,35 – 1,50						
1,55 – 1,70		4,5	3			
1,75 – 1,90						
1,95 – 2,00						
2,05 – 2,20						
2,25 – 2,50						
2,55 – 2,95						

225.

d ₁	diameter steps		d ₂	d ₃	l ₁
0,1–0,45	0,05	3	2		stock lengths: 71 mm. other lengths and diameters on request.
0,50					
0,55					
0,60					
0,65					
0,70 + 0,75					
0,80 + 0,85					
0,90 + 0,95					
1,00 – 1,10					
1,15 – 1,30					
1,35 – 1,50					
1,55 – 1,70		4,5	3		
1,75 – 1,90					
1,95 – 2,00					
2,05 – 2,20					
2,25 – 2,50					
2,55 – 2,95					

FIBRO

274.
275.

Precision Punches Similar to DIN 9861 Shape CA+C

274. Shape CA

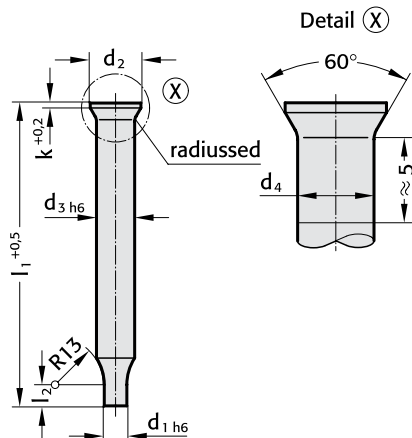

275. Shape C

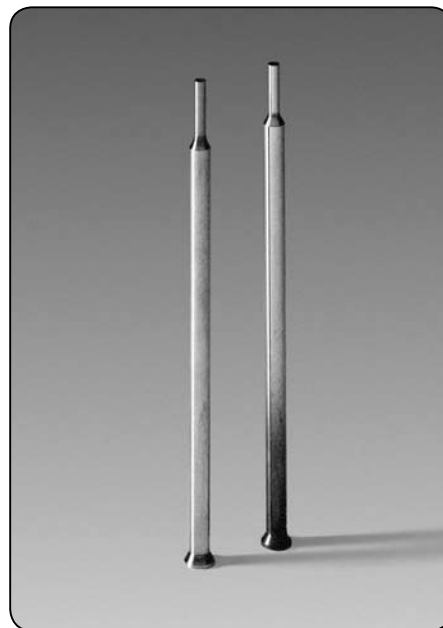
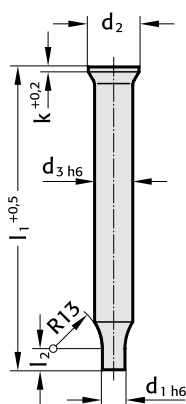

Material:

HZ – TIN (HSS)

Order No: Form CA = 274.0.
Form C = 275.0.
Hardness: Surface 2300 HV 0,05
Head 52±3 HRC

HSS

Order No: Form CA = 274.3.
Form C = 275.3.
Hardness: Shank 64±2 HRC
Head 52±3 HRC

HST

Order No: Form CA = 274.4.
Form C = 275.4.
Hardness: Surface ≥950 HV 0,3
Head 52±3 HRC

ASP 23 – ASP 2023

Order No: Form C = 275.6.
Hardness: Shank 64±2 HRC
Head 52±3 HRC

Description of FIBRO materials for die components:
pages E 10–E 11.

Execution:

Shape CA

Shank precision ground, head subsequently hot upset-forged and tempered; residual upset-bulge below head normally much smaller than permissible acc. to DIN 9861.

Shape C

Head hot upset-forged and tempered.

Shank and head subsequently precision plunge-ground for perfect concentricity and full interchangeability with replacement punches.

Description of Special Series 274. and 275.

DIN 9861 restricts the range of stepped punches with conical head to shanks of 3 mm max. diameter and points of 2,95 mm max. diameter.

Stepped punches of larger size are, however, quite popular owing to their rigidity and ability to sustain considerable stripping forces.

In accommodation of this demand we supply larger sizes which are ground from stock sizes of the 222.-and 223.-series

Please select from those ranges and complete your order in accordance with the example on the right.

Ordering Code (example):

Punch CA	=	274.
Material HSS	=	3.
$d_3 = \varnothing 8,0$ mm	=	0800.
$l_1 = 71$ mm	=	071.
$d_1 = \varnothing 6,4$ mm	=	0640.
$l_2 = 10$ mm	=	010
Order No	=	274.3.0800.071.0640.010

Stepped Quill Punches – Conical Head
 Head Type Quill Bush and Thrust Pin
 Ball Lock Type Quill Bush and Thrust Pin VDI 3374

FIBRO

232. 233.
 234.



232.

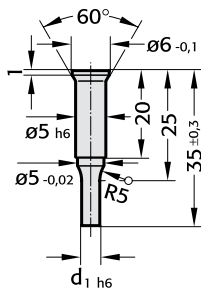

VDI 3374

233. Shape A

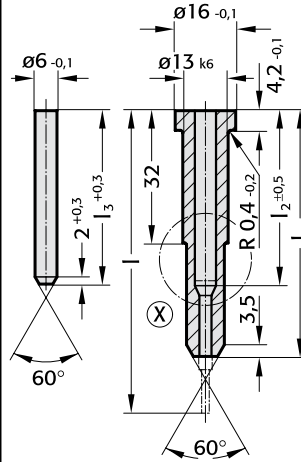

VDI 3374

234. Shape B

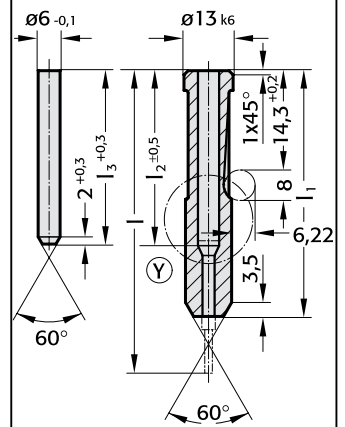

VDI 3374

233.

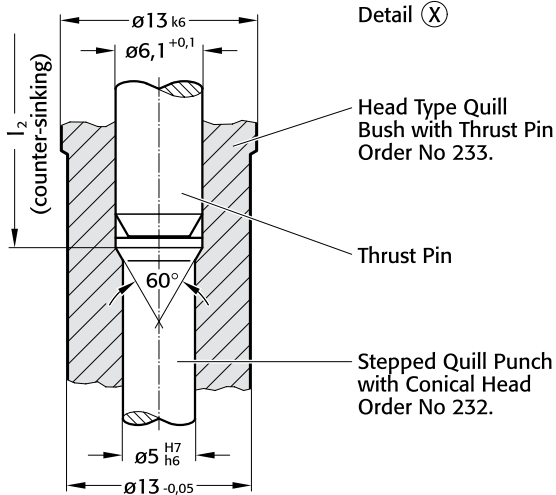

Detail (X)

Head Type Quill Bush with Thrust Pin Order No 233.

Thrust Pin

Stepped Quill Punch with Conical Head Order No 232.

234.

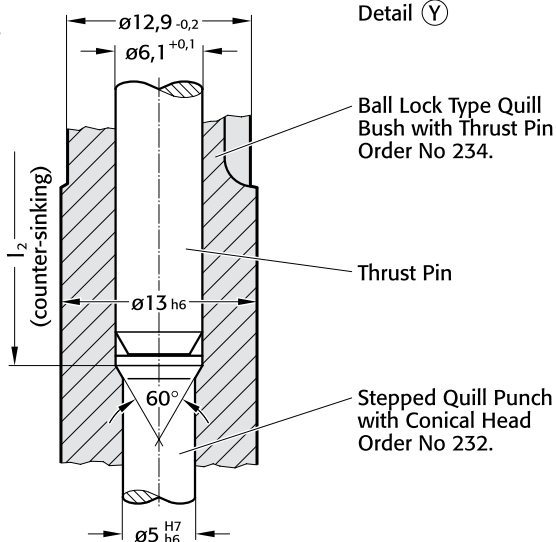

Detail (Y)

Ball Lock Type Quill Bush with Thrust Pin Order No 234.

Thrust Pin

Stepped Quill Punch with Conical Head Order No 232.

Execution:

Heads of Quill Punches hot upset-forged; shank and head subsequently precision plunge-ground.
 O. D. of Quill Bushes precision ground.
 Thrust Pins are hardened, tempered and ground.

Material:

Stepped Quill Punches – Conical Head VDI 3374:

HSS
 Order No: 232.3.
 Hardness: Shank 62±2 HRC
 Head 45±5 HRC

Quill Bushes O. No. 233. and 234. – VDI:
 Steel C 45 heat treated to 800 N/mm2
 Order No: Shape A = 233.7., Shape B = 234.7.

Thrust Pin:
 HWS
 Hardness: 62±2 HRC

Description of FIBRO materials for die components:
 pages E 10– E 11.

232./233./234.

diameter steps					
d_1	d_1	l	l_1	l_2	l_3
from 2,0 bis 5,0	0,1	63	48	29	29
		71	57	37	37
		80	65	46	46

Ordering Code (example):

Stepped Quill Punch/Conical Head = 232.
 Material HSS = 3.
 $d_1 = \varnothing 2,2$ mm = 0220
 Order No = 232.3.0220

Ordering Code (example):

Head Shape Quill bush + Thrust Pin = 233.
 Material C 45 = 7.
 $l_1 = 48$ mm = 048
 Order No = 233.7.048

FIBRO

2281.
2291.

Round Precision Punches with tapered heads 30°, Shape C+D

2281. Shape D

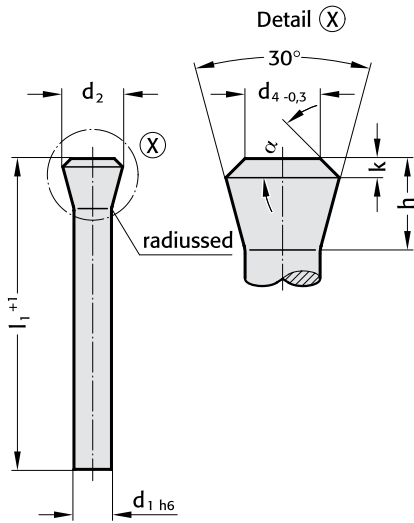

2291. Shape C

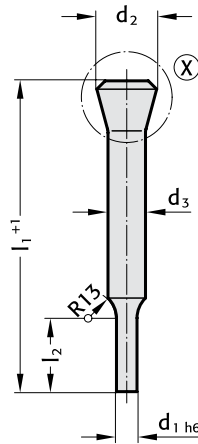

Material:

HSS
Order No.: Shape D = 2281.3.
Shape C = 2291.3.
Hardness: Shank 58 + 2 HRC
Head ≤ 50 HRC

Execution:

Shape C and D
Head hot upset-forged and tempered.
Shank and head subsequently precision plunge-ground for perfect concentricity and full interchangeability with replacement punches.

Description of FIBRO materials for die components:
pages E 10 – E 11.

2281. Shape D

d ₁	d ₂	d ₄	h	k	α ± 1°	l ₁	
						100	120
5,5	8,98	5,5	7,5	1	30	●	●
6	9,75	6	8		28	●	●
8	12,8	8	10		22,5	●	●
9	14,4	9	11		20	●	●
10	15,9	10	12		19	●	●
12	18,7	12	14	1,5	24		●
14	21,8	14	16		21		●
16	24,6	16	18	2	25		●

Ordering Code (example):

Punch = 2281.
Material HSS = 3.
d₁ = 6 mm = 0600.
l₁ = 100 mm = 100
Order No = 2281.3.0600.100

2291. Shape C

d ₃	d ₂	d ₄	h	k	α ± 1°	l ₁	
						100	120
5,5	8,98	5,5	7,5	1	30	●	●
6	9,75	6	8		28	●	●
8	12,8	8	10		22,5	●	●
9	14,4	9	11		20	●	●
10	15,9	10	12		19	●	●
12	18,7	12	14	1,5	24		●
14	21,8	14	16		21		●
16	24,6	16	18	2	25		●

d₁ and l₂ to customer's specifications!

Ordering Code (example):

Punch = 2291.
Material HSS = 3.
d₃ = 10 mm = 1000.
l₁ = 120 mm = 120.
d₁ = 6 mm = 0600.
l₂ = 15 mm = 015
Order No = 2291.3.1000.120.0600.015

**Punch with tapered head, Shape D
Piloted counterbore for tapered-head punch**

**2284.3.
2284.00.**



2284.3.

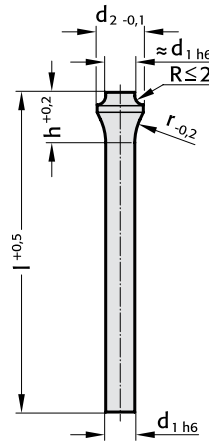

2284.3. Shape D

Material: HSS
Order Code: 2284.3.
Hardness: Shaft 62 - 66 HRC
Head 45 - 55 HRC

Execution:

Punch shaft fine ground.
Punch head warm upset-forged and tempered.

For description of material and other materials see pages E10 - E11.

Ordering Code (example):

Punch with tapered head	= 2284.
Material HSS	= 3.
d ₁ = 20 mm	= 2000.
l = 100 mm	= 100
Order Code	= 2284.3.2000.100

2284.00.

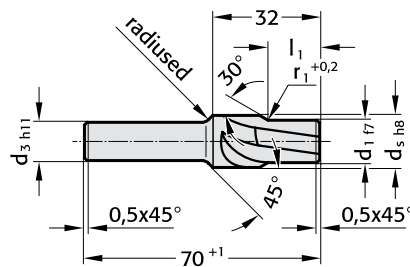

2284.00.

Material: HSS
Hardness: 62 - 66 HRC

Execution:

hardened, tempered and ground

Ordering Code (example):

Piloted counterbore for tapered-head punch	= 2284.00.
d ₁ = 12.5 mm	= 1250
Order Code	= 2284.00.1250

FIBRO

2284.3.
2284.00.

Punch with tapered head, Shape D
Piloted counterbore for tapered-head punch

2284.3.							2284.00.					
d ₁	d ₂	h	r	71	80	l	100	110	d ₅	d ₃	r ₁	l ₁
2.0	3	4.80	3.5	●	●		●		3.3	3.3	3.5	5.0
2.1	3.2	5.28	5	●	●		●		3.5	3.5	5.0	5.0
2.2	3.2	5.18	5	●	●		●		3.5	3.5	5.0	5.0
2.3	3.5	5.37	5	●	●		●		3.8	3.8	5.0	5.0
2.4	3.5	5.28	5	●	●		●		3.8	3.8	5.0	5.0
2.5	3.5	5.18	5	●	●		●		3.8	3.8	5.0	5.0
2.6	4	5.93	6.5	●	●		●		4.3	4.3	6.5	7.0
2.7	4	5.83	6.5	●	●		●		4.3	4.3	6.5	7.0
2.8	4	5.73	6.5	●	●		●		4.3	4.3	6.5	7.0
2.9	4	5.62	6.5	●	●		●		4.3	4.3	6.5	7.0
3.0	4.5	6.03	6.5	●	●		●		4.9	4.9	6.5	7.0
3.1	4.5	5.93	6.5	●	●		●		4.9	4.9	6.5	7.0
3.2	4.5	5.83	6.5	●	●		●		4.9	4.9	6.5	7.0
3.3	4.5	5.73	6.5	●	●		●		4.9	4.9	6.5	7.0
3.4	4.5	5.62	6.5	●	●		●		4.9	4.9	6.5	7.0
3.5	5	6.38	8	●	●		●		5.4	5.4	8.0	7.0
3.6	5	6.27	8	●	●		●		5.4	5.4	8.0	7.0
3.7	5	6.16	8	●	●		●		5.4	5.4	8.0	7.0
3.8	5	6.04	8	●	●		●		5.4	5.4	8.0	7.0
4.0	5.5	7.38	8	●	●		●		5.9	5.9	8.0	8.0
4.1	5.5	7.27	8	●	●		●		5.9	5.9	8.0	8.0
4.2	5.5	7.16	8	●	●		●		5.9	5.9	8.0	8.0
4.3	5.5	7.04	8	●	●		●		5.9	5.9	8.0	8.0
4.4	5.5	6.92	8	●	●		●		5.9	5.9	8.0	8.0
4.5	6	7.38	8	●	●		●		6.4	6.4	8.0	8.0
4.6	6	7.27	8	●	●		●		6.4	6.4	8.0	8.0
4.7	6	7.16	8	●	●		●		6.4	6.4	8.0	8.0
4.8	6	7.04	8	●	●		●		6.4	6.4	8.0	8.0
4.9	6	6.92	8	●	●		●		6.4	6.4	8.0	8.0
5.0	7	8.36	10	●	●		●		7.4	7.4	10.0	10.0
5.1	7	8.25	10	●	●		●		7.4	7.4	10.0	10.0
5.2	7	8.15	10	●	●		●		7.4	7.4	10.0	10.0
5.5	8	8.84	10	●	●		●		8.5	8.5	10.0	10.0
5.6	8	8.75	10	●	●		●		8.5	8.5	10.0	10.0
6.0	9	9.27	10	●	●		●		9.5	9.5	10.0	10.0
6.1	9	9.19	10	●	●		●		9.5	9.5	10.0	10.0
6.2	9	9.10	10	●	●		●		9.5	9.5	10.0	10.0
6.3	9	9.02	10	●	●		●		9.5	9.5	10.0	10.0
6.4	9	8.93	10	●	●		●		9.5	9.5	10.0	10.0
6.5	10	10.24	12	●	●		●	●	10.5	10.5	12.0	12.0
7.0	10	9.81	12	●	●		●		10.5	10.5	12.0	12.0
7.5	11	10.24	12	●	●		●		11.5	11.5	12.0	12.0
7.7	11	10.07	12	●	●		●		11.5	11.5	12.0	12.0
8.0	11	9.81	12	●	●		●	●	11.5	11.5	12.0	12.0
8.1	11	9.72	12	●	●		●		11.5	11.5	12.0	12.0
8.5	13	11.90	15	●	●		●		13.5	13.0	15.0	12.0
9.0	13	11.48	15	●	●		●	●	13.5	13.0	15.0	12.0
9.5	14	11.90	15	●	●		●		14.5	13.0	15.0	12.0
10.0	14	11.48	15	●	●		●	●	14.5	13.0	15.0	12.0
10.5	15	11.90	15	●	●		●		15.5	13.0	15.0	15.0
11.0	15	11.48	15	●	●		●		15.5	13.0	15.0	15.0
11.5	16	11.90	15	●	●		●		16.5	13.0	15.0	15.0
12.0	16	11.48	15	●	●		●	●	16.5	13.0	15.0	15.0
12.5	17	11.90	15	●	●		●		17.5	13.0	15.0	15.0
13.0	17	11.48	15	●	●		●	●	17.5	13.0	15.0	15.0
13.5	18	11.90	15	●	●		●		18.5	13.0	15.0	15.0
14.0	18	11.48	15	●	●		●	●	18.5	13.0	15.0	15.0
14.5	19	11.90	15	●	●		●		19.5	13.0	15.0	15.0
15.0	19	11.48	15	●	●		●	●	19.5	13.0	15.0	15.0
15.5	20	11.90	15	●	●		●		20.5	13.0	15.0	15.0
16.0	20	11.48	15	●	●		●	●	20.5	13.0	15.0	15.0
17.0	21	11.48	15	●	●		●	●	21.5	16.0	15.0	15.0
18.0	22	11.48	15	●	●		●	●	22.5	16.0	15.0	15.0
19.0	23	11.48	15	●	●		●		23.5	16.0	15.0	15.0
19.5	25	12.66	15	●	●		●		25.5	16.0	15.0	15.0
20.0	25	12.29	15	●	●		●		25.5	16.0	15.0	15.0

Assembly Guide Lines for Head Type Punches with Round Points

Description:

Head type punches with round point (DIN 9844) are intended for floating assembly in the punch retainer. Radial guiding is to be provided by the stripper.

This type of punch assembly eliminates alignment errors caused by distorted mounting of the die set and faulty press geometry. With punches held in this manner, a clear separation between transmission of perforation force and guiding is achieved.

In order to facilitate assembly of punches of different diameters, the height of the heads is standardized to $4_{+0,2}$ mm (DIN 9844).

Guide Lines:

(excerpts from DIN 9844, page 5)

d_1 max. = stock thickness

stripping force*, for d_1 from 1 to 5 mm: approx. 20 % of piercing force
ditto . . . , for d_1 from 5 to 16 mm: approx. 10 % of piercing force

*applicable to stock not exceeding 400 N/mm² shear strength

Punch retainer: steel of at least 300 N/mm² tensile strength

Retaining hole in punch retainer = 1,05 times d_1 or d_2 respectively

Clearance punch head/percussion plate = 0,02 mm.

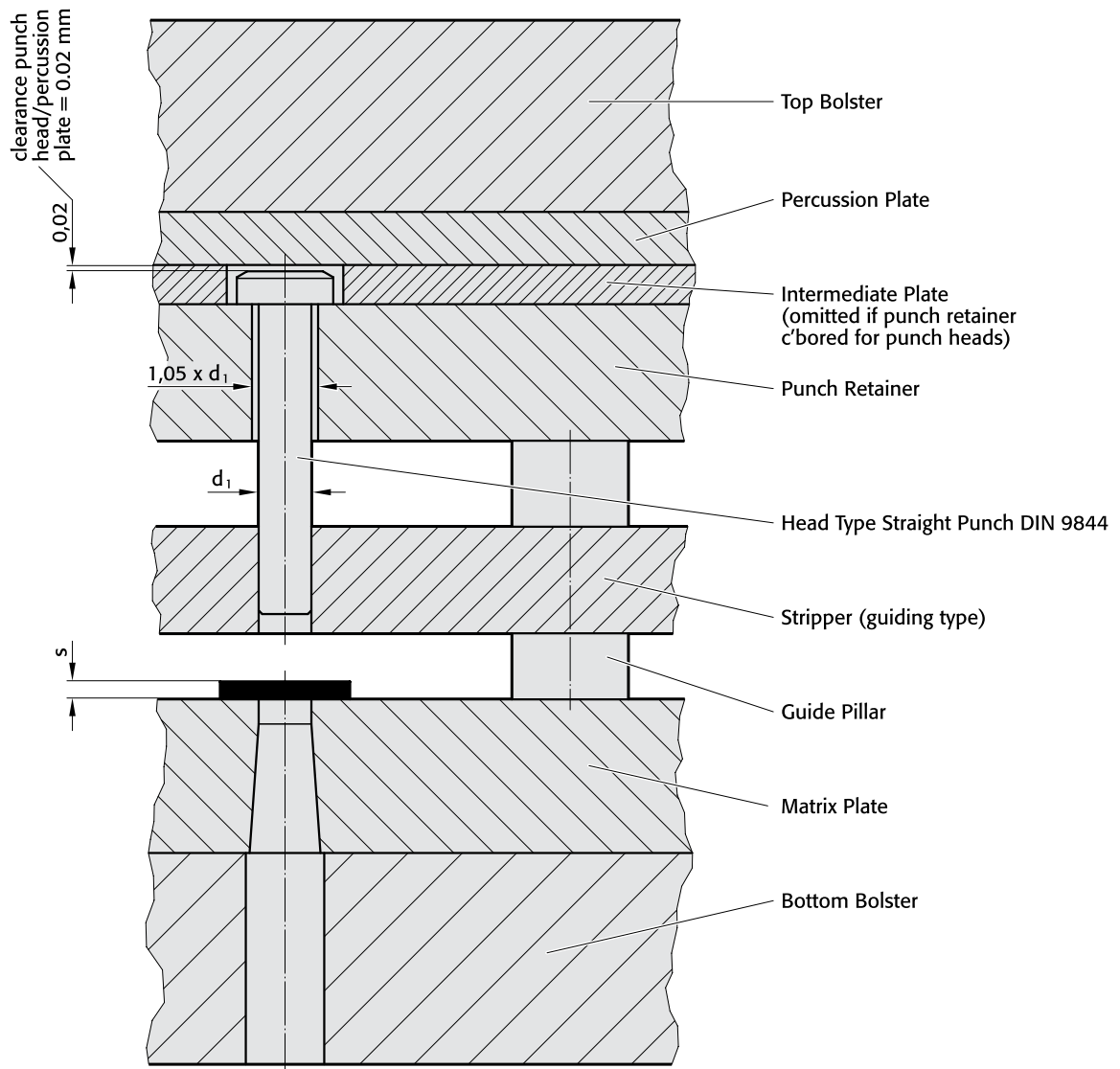

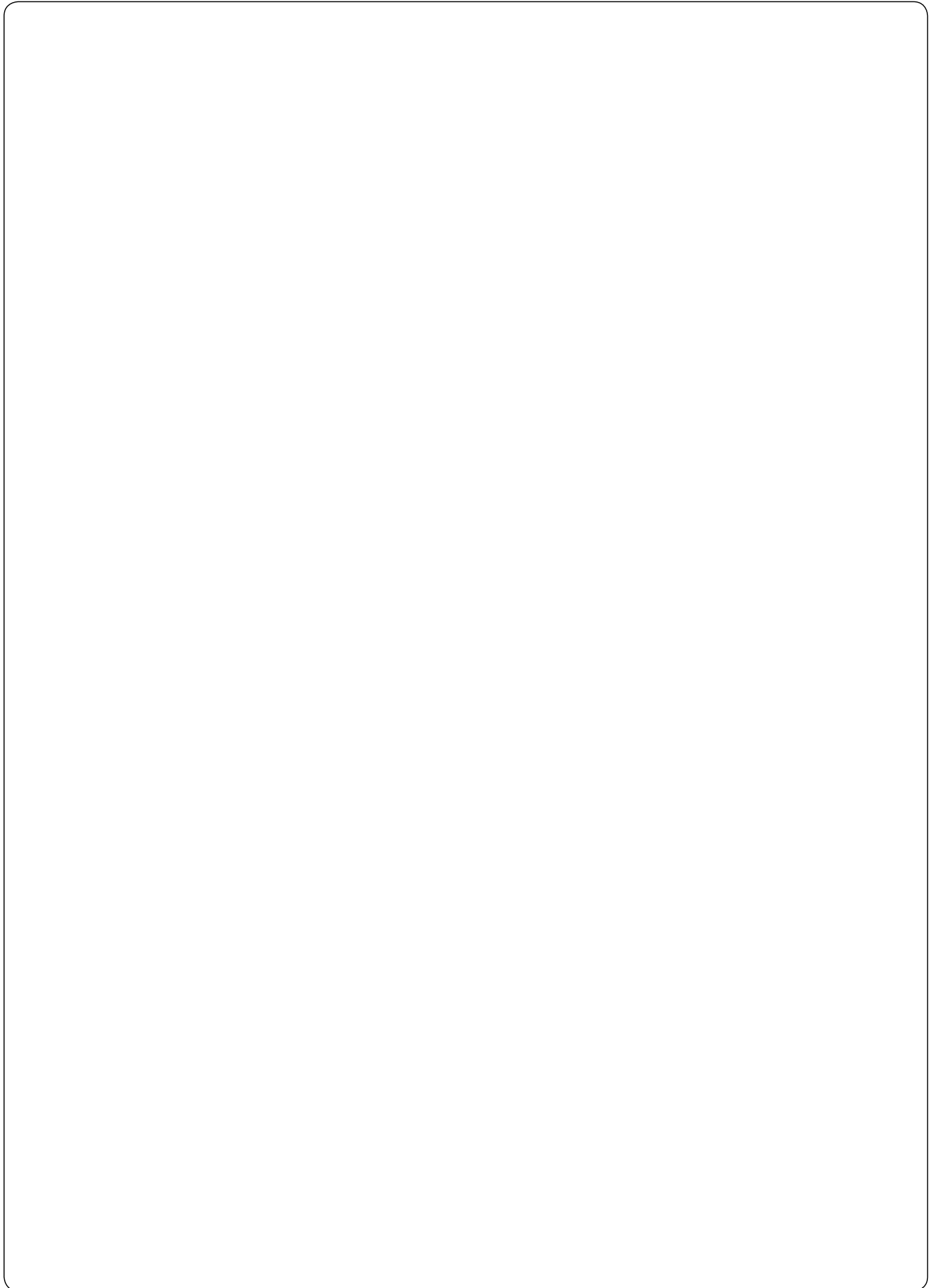

266.

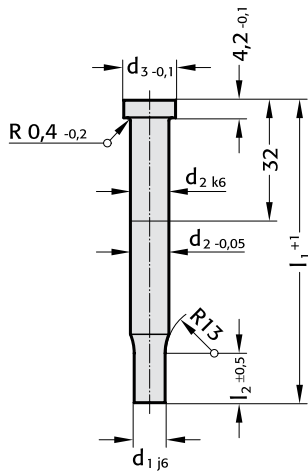

Werkstoff:

HSS
Order No.: 266.3.
Hardness: Shank 62±2 HRC
Head 45±5 HRC

Execution:

Head hot upset-forged; shank and head precision plunge-ground.

Ordering Code (example):

Punch	=	266.
Material HSS	=	3.
d ₁ = 8,0 mm	=	0800.
l ₁ = 71 mm	=	071
Order No	=	266.3.0800.071

Description of FIBRO materials for die components:
pages E 10 and E 11.

266.

diameter steps

d ₁	d ₁	d ₂	d ₃	l ₂	l ₁ ⁺¹
5- 8,9	0,1	10	13	13	
9-11,9		13	16		
12-15,9		16	19		
16-19,9	0,5	20	24		
20-24,9		25	29		

available at short notice in lengths:
71 and 80 mm; other lengths and dia. on request.

Precision Punches with Ejector Pin

267.



267.

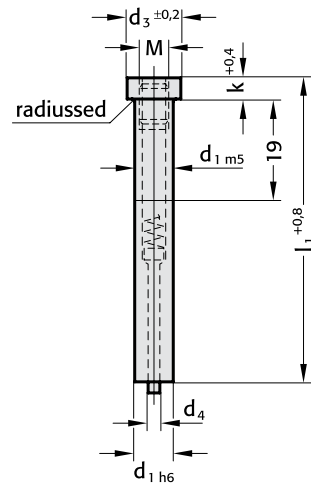

Execution:

Head hot upset-forged.
Shank and shoulder precision plunge-ground.

Material:

HSS
Order No: 267.3.
Hardness: Shank 64±2 HRC
Head 52±3 HRC

Ordering Code (example):

Punch	=	267.
Material HSS	=	3.
d ₁ = 8,0 mm	=	0800.
l ₁ = 71 mm	=	071
Order No	=	267.3.0800.071

Description of FIBRO materials for die components:
pages E 10 and E 11.

267.

d _{1-h6}	d ₃	d ₄	k	l ₁				M
				60	71	80	90	
5	8	0,5	5	●	●			M 3
6	9	0,8		●	●	●	●	
8	11	1,3		●	●	●	●	M 4
10	13			●	●	●	●	
13	16	1,6		●	●	●	●	M 5
16	19	2,4	6,4	●	●	●	●	M 6
20	23			●	●	●	●	
25	28	3,2		●	●	●	●	

FIBRO

268.
269.

Precision Punches with Ejector Pin, Stepped, Short/Long Point

Classified Point Shapes

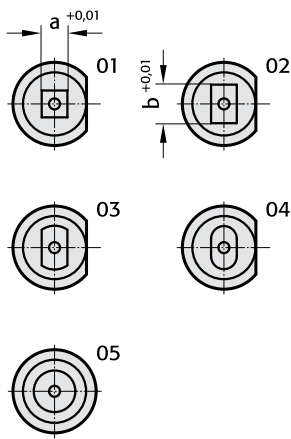

268.

269.

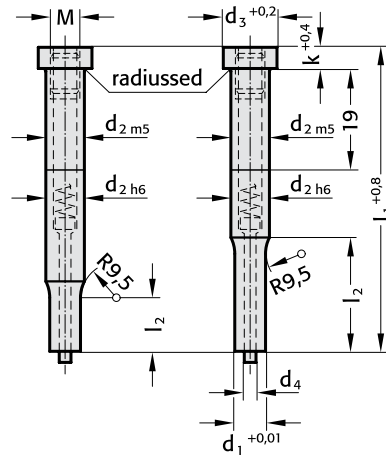

Material:

HSS
Order No: 268.3. (short point)
Hardness: Shank 64±2 HRC
Head 52±3 HRC

HSS
Order No: 269.3. (long point)
Hardness: Shank 64±2 HRC
Head 52±3 HRC

Description of FIBRO materials for die components:
pages E 10 and E 11.

Execution:

Head hot upset-forged.
Shank and shoulder precision plunge-ground.

Key flats parallel with longest size of shape, unless otherwise specified.

Ordering Code (example):

Punch	=	268.
Material HSS	=	3.
d ₂ = 8,0 mm	=	0800.
l ₁ = 71 mm	=	071.
Classified Point Shape 05	=	05.
d ₁ = 6,0 mm	=	0600
Order No	=	268.3.0800.071.05.0600

268./269.

268. 269.

d ₁	d ₂	d ₃	d ₄	k	l ₂	l ₂	60	71	l ₁	80	90	a min.	M
1,6- 4,9	5	8	0,5	5	7	-	●	●				1,6	M 3
2,3- 5,9	6	9	0,8			17,5	●	●		●	●	2,3	
3,5- 7,9	8	11	1,3		13	25	●	●		●	●	3,2	M 4
5,0- 9,9	10	13				28	●	●		●	●	4,8	
6,0-12,9	13	16	1,6				●	●		●	●		M 5
8,0-15,9	16	19	2,4	6,4			●	●		●	●	5,5	M 6
12,0-19,9	20	23					●	●		●	●		
16,0-24,9	25	28	3,2				●	●		●	●	6,5	

Sintered Hard Metal HIP-Densified

The HIP Process (hot isostatic pressing) consists of a special densification treatment.

Applied after the sintering stage, this widely used process involves compacting, at very high temperature and pressure, of the carbide structure. It yields an appreciable reduction in porosity, better strength properties and thus longer die life of press tool members.

As can be seen from the diagrams and tables, both compressive and flexural strength are improved.

For stamping die tooling, hard metal types of medium tungsten particle size, with a cobalt content of 9 to 12%, have been found successful in a wide field of applications.

Tensile Strength of Tungsten – 6% Cobalt Carbide in the Sintered-Only versus HIP-Densified State, in Dependence of Crystallite Particle Size

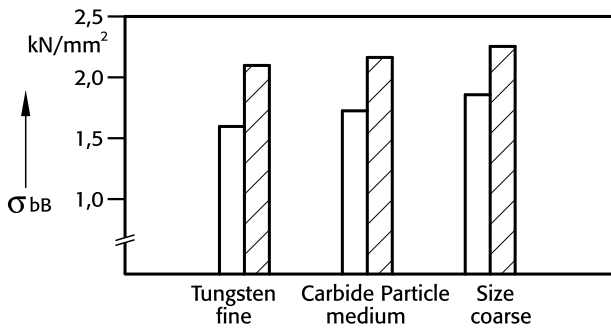

a) influence of crystallite size of hard metal phase
(left: sintered only – right: sintered and HIP-treated)

Tensile Strength of Tungsten – Cobalt Carbide in the Sintered-Only versus HIP-Densified State, in Dependence of total Cobalt Content

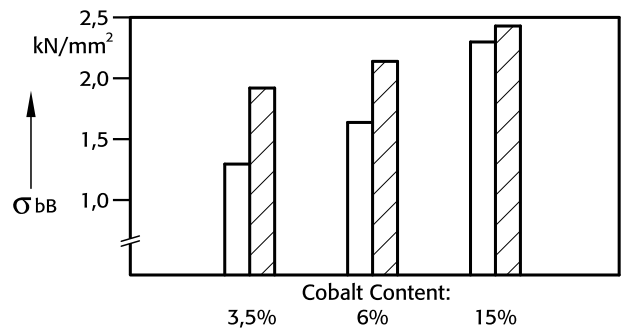

b) influence of cobalt content
(left: sintered only – right: sintered and HIP-treated)

Tungsten carbide-particle size	Co %	HV ₃₀ -Hardness		Flexural Strength N/mm ²	
		befor	after	befor	after
fine	3	1800	no changes	1200	1700
	6	1650		1500	2300
	9	1400		2000	2600
medium	6	1600		2000	2600
	9	1450		2350	2700
	12	1300		2450	2900
	15	1200		2700	2850
coarse	6	1400		1900	2250
	8	1350		2300	2600
	10	1200	2650	2850	

Flexural Strength and HV30-Hardness of Tungsten-Cobalt Carbides with/without HIP-Treatment and in Dependence of Tungsten Carbide Particle Size and Cobalt Content.

FIBRO

270. 272.
271. 273.

Carbide Punches – similar to DIN 9844 + DIN 9861

Cylindrical Head – Straight and Stepped

Conical Head – Straight and Stepped

270. Shape A

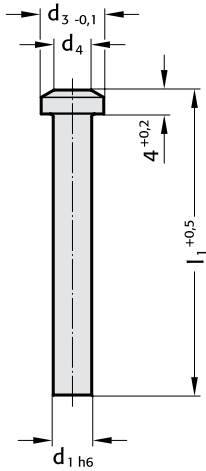

271. Shape B

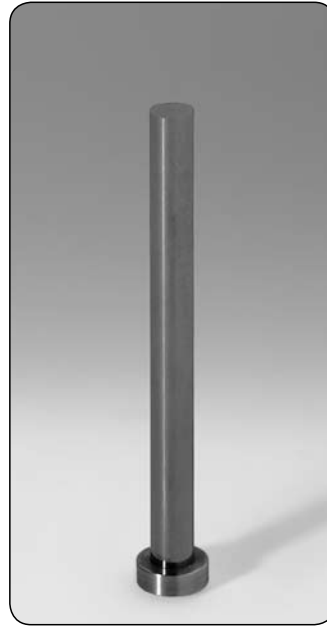
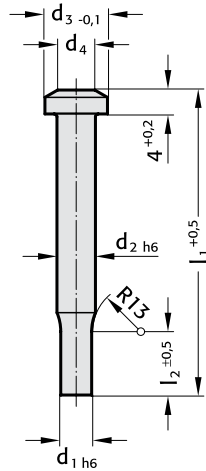

272. Shape D

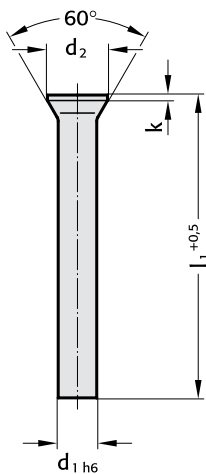

273. Shape C

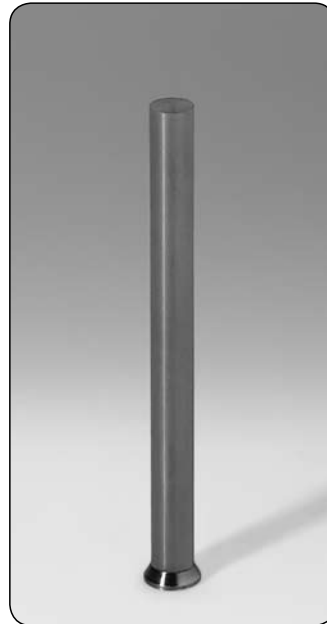
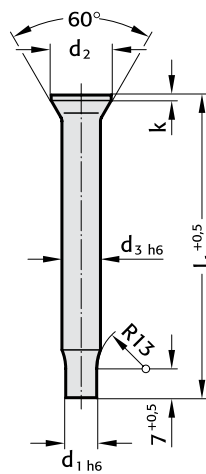

Material:

Tungsten-Cobalt Carbide

Order No: Shape A = 270.9., Shape B = 271.9.
 Shape D = 272.9., Shape C = 273.9.

Dimensions:

See DIN 9844 and DIN 9861 on pages E 12, E 13, E 14, E 15 and E 21.
Other diameters and lengths on request.

Delivery:

270.
Shape A from $d_1 = 1,0$ mm
272.
Shape D from $d_1 = 1,5$ mm

Execution:

Heads steel, brazed to shanks.
Shanks precision ground.

Ordering Code (example):

Carbide Punch	= 272.
Material: Tungsten-Cobalt Carbide	= 9.
$d_1 = 6,0$ mm	= 0600.
$l_1 = 71$ mm	= 071
Order No	= 272.9.0600.071

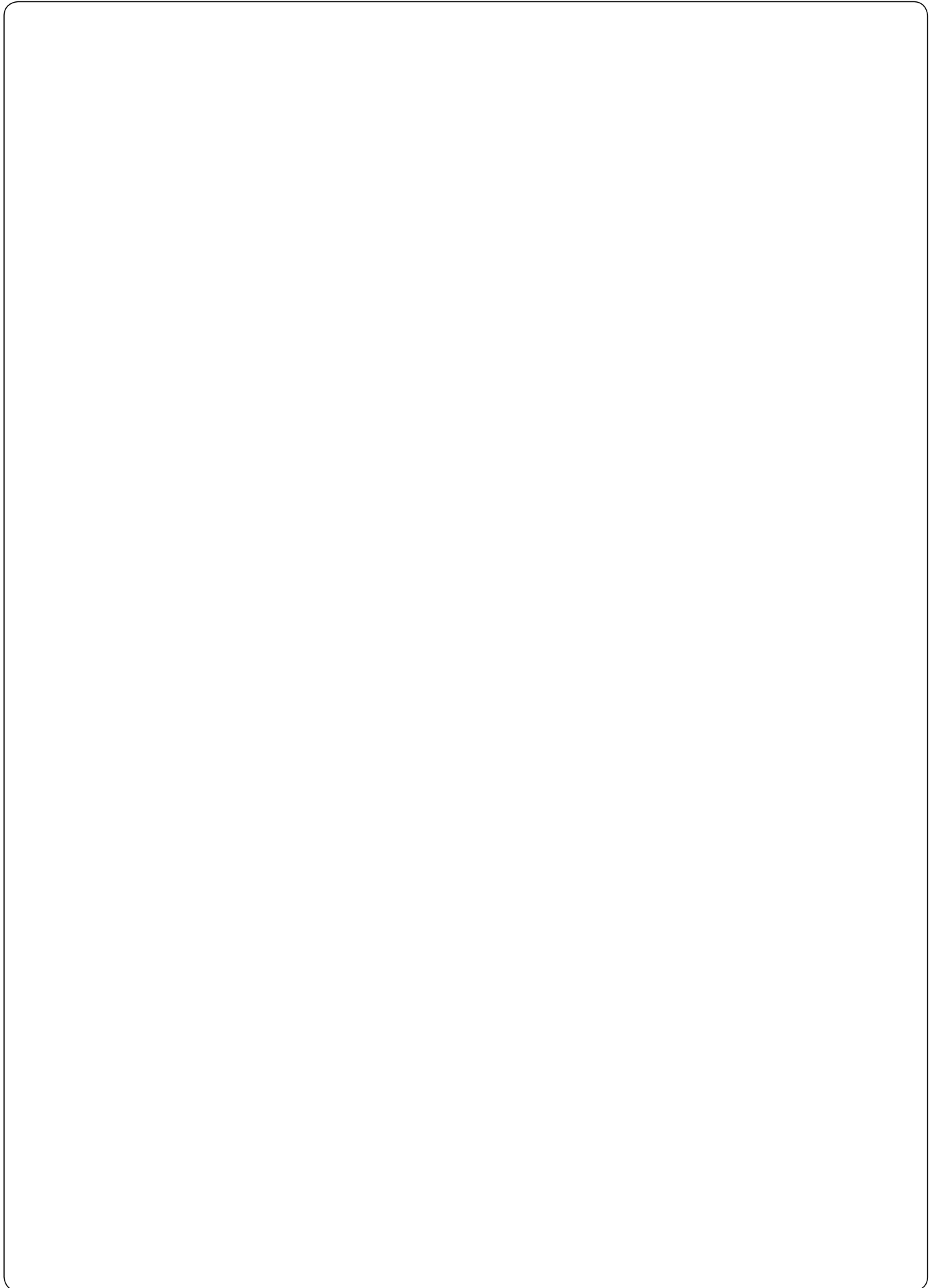

Ball-Lock Punches

A large, empty rectangular box with rounded corners, occupying most of the page. It is intended for drawing or writing.

Ordering example Ball-Lock Punches

NB: See table for standard dimensions
Special dimensions to order

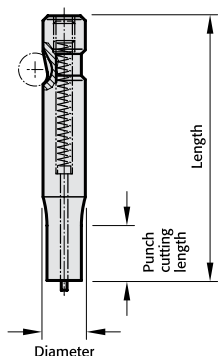

Punch:
22 without ejector pin
27 with ejector pin

2 2 4 2 . 2 F 1 . 0 6 5 0 . 0 4 5 0 B

Punch cutting length: l_1	Order No
13	= 1
19	= 2
25	= 3
30	= 4
special	= X

Format: Slot length P = 6,5 mm

Format: Slot width W = 4,5 mm

Version:	Order No
○ blank	= 0
⊙ round	= 1
□ square	= 2
▭ rectangular	= 3
◻ slot	= 4
◻ rectangle with radiused corners	= 5
▽ pilot pin with tapered tip	= 6
∇ pilot pin parabolic tip	= 7
special shapes	= 9

Type:	Order No
light	= 2
heavy	= 3
punch larger, light	= 4
punch larger, heavy	= 5

Diameter: d_2	Order No
6 (light duty only)	= 1
10	= 2
13	= 3
16	= 4
20	= 5
25	= 6
32	= 7
38 (light duty only)	= 8
40 (heavy duty only)	= 9

Length: l	Order Code character
50	= A
56	= B
63	= C
71	= D
80	= E
90	= F
100	= G
110	= H
125	= J
140	= K
150	= L
175	= M
200	= N
special	= X

Angle:	Order Code character
0°	= A
90°	= B
180°	= C
270°	= D
special	= X

Ordering Code (Example):

2 2 4 2 . 2 F 1 . 0 6 5 0 . 0 4 5 0 B

- Angle = 90° (B)
- Format: Slot, width W = 4,5 mm (0450)
- Format: Slot, length P = 6,5 mm (0650)
- Punch cutting length: l_1 = 13 mm (1)
- Length: l = 90 mm (F)
- Diameter: d_2 = 10 mm (2)
- Type = light (2)
- Version: Slot (4)
- Punch: without ejector pin (22)

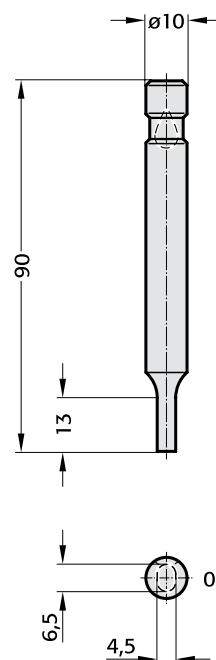

Ball-Lock Punches
blank, light duty

2202.

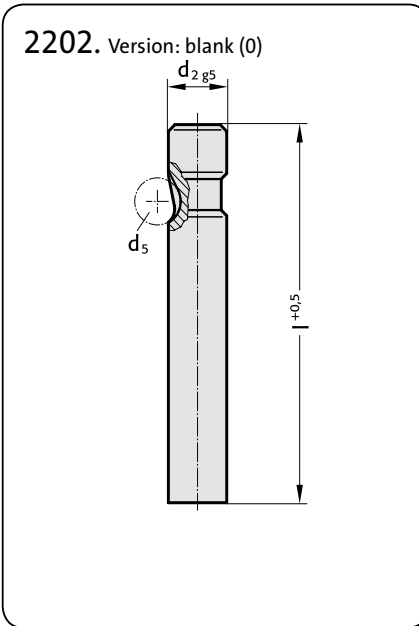

Material:
HSS
hardened: 62 ± 2 HRC

Execution:
Shaft fine ground.

Ordering Code (Example):
Synopsis see fold out page E31

2202.

d ₂ / (Order No)	d ₅	l / (Order Code character)										
		63 (C)	71 (D)	80 (E)	90 (F)	100 (G)	110 (H)	125 (J)	140 (K)	150 (L)	175 (M)	200 (N)
6 (1)	6	●	●	●	●	●						
10 (2)	8	●	●	●	●	●	●	●				
13 (3)	8	●	●	●	●	●	●	●	●	●	●	
16 (4)	8	●	●	●	●	●	●	●	●	●	●	●
20 (5)	8	●	●	●	●	●	●	●	●	●	●	●
25 (6)	8	●	●	●	●	●	●	●	●	●	●	●
32 (7)	8		●	●	●	●	●	●	●	●	●	●
38 (8)	8			●	●	●	●	●	●	●	●	●

Other lengths on request.

Ordering Code (Example):

2 2 0 2 . 7 G

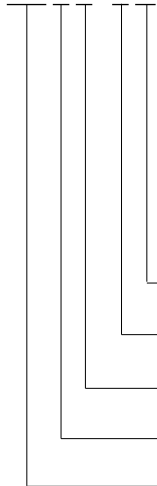

Length: l
100 mm
Diameter: d₂
32 mm
Type:
light
Version:
blank
Punch:
22 without ejector pin

Order Code character
= (G)
Order No
= (7)
Order No
= (2)
Order No
= (0)

Material:

HSS
hardened: 62 ± 2 HRC

Execution:

Shaft and punch diameter fine ground.

2212. Version: Round (1)

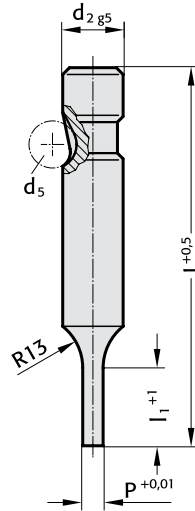

Ordering example:

Synopsis see fold out page E31

2212.

d ₂ / (Order No)	d ₅	P	l ₁ / (Order No)	l / (Order Code character)				
				63 (C)	71 (D)	80 (E)	90 (F)	100 (G)
6 (1)	6	1,6 - 5,9	13* (1)	●	●	●	●	●
10 (2)	8	1,6 - 9,9	13* (1) 19*(2)	●	●	●	●	●
13 (3)	8	5,0-12,9	13 (1) 19 (2)	●	●	●	●	●
16 (4)	8	8,0-15,9	13 (1) 19 (2) 25 (3)	●	●	●	●	●
20 (5)	8	12,0-19,9	13 (1) 19 (2) 25 (3)	●	●	●	●	●
25 (6)	8	16,0-24,9	13 (1) 19 (2) 25 (3)	●	●	●	●	●
32 (7)	8	24,0-31,9	13 (1) 19 (2) 25 (3)		●	●	●	●
38 (8)	8	30,0-37,9	19 (2) 25 (3) 30 (4)			●	●	●

* l₁ = 10 where P < 2,20

Other lengths on request

Ordering example:

2 2 1 2 . 7 G 2 . 2 4 5 0

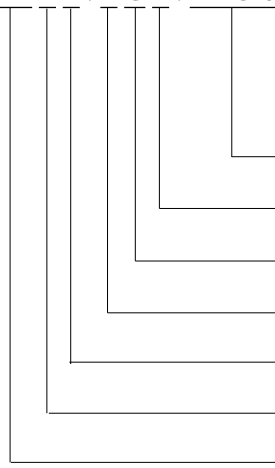

Format: Round
P = ø24,5 mm
Punch cutting length: l₁ 19 mm
Length: l 100 mm
Diameter: d₂ 32 mm
Type: light
Version: Round
Punch: without ejector pin (22)

= (2450)
Order No
= (2)
Order Code character
= (G)
Order No
= (7)
Order No
= (2)
Order No
= (1)

**Ball-Lock Punches,
stepped, light duty**

2222. 2232.
2242. 2252.



2222. Version: Square (2)

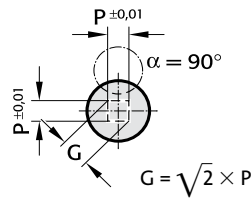

2232. Version: Rectangular (3)

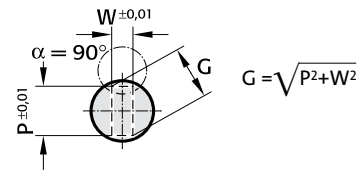

2242. Version: Slot (4)

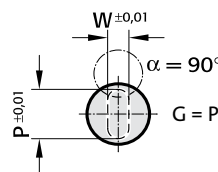

2252. Version: Rectangle with radiused corners (5)

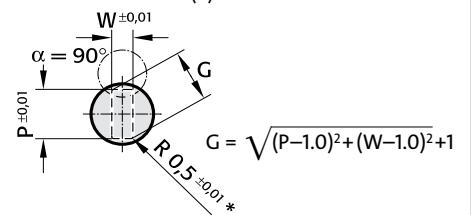

* For other radius options, see standardised special shapes, pages E 100 – E 101

2222./ 2232./ 2242. / 2252.

d ₂ / (Order No)	d ₅	W _{min.}	G _{max.}	l ₁ / (Order No)	l / (Order Code character)				
					63 (C)	71 (D)	80 (E)	90 (F)	100 (G)
6 (1)	6	1,6	5,9	13*(1)	●	●	●	●	●
10 (2)	8	1,6	9,9	13*(1) 19*(2)	●	●	●	●	●
13 (3)	8	4,5	12,9	13 (1) 19 (2)	●	●	●	●	●
16 (4)	8	6,0	15,9	13 (1) 19 (2) 25 (3)	●	●	●	●	●
20 (5)	8	8,0	19,9	13 (1) 19 (2) 25 (3)	●	●	●	●	●
25 (6)	8	10,0	24,9	13 (1) 19 (2) 25 (3)	●	●	●	●	●
32 (7)	8	12,5	31,9	13 (1) 19 (2) 25 (3)	●	●	●	●	●
38 (8)	8	14,0	37,9	19 (2) 25 (3) 30 (4)	●	●	●	●	●

*l₁ = 10 where P or W < 2,20

Other lengths on request

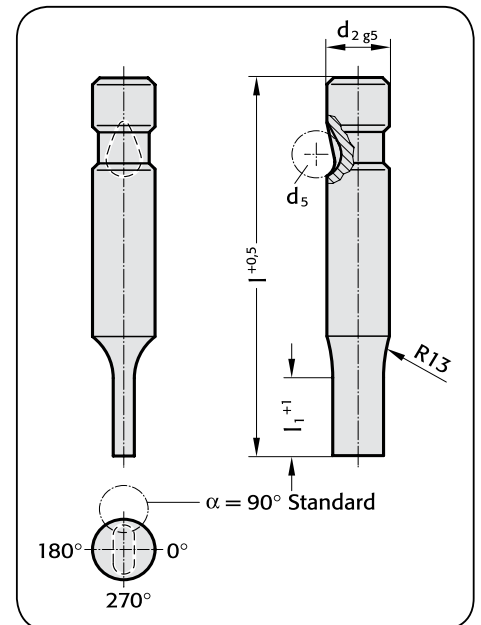

Ordering example:

2 2 4 2 . 2 F 1 . 0 6 5 0 . 0 4 5 0 B

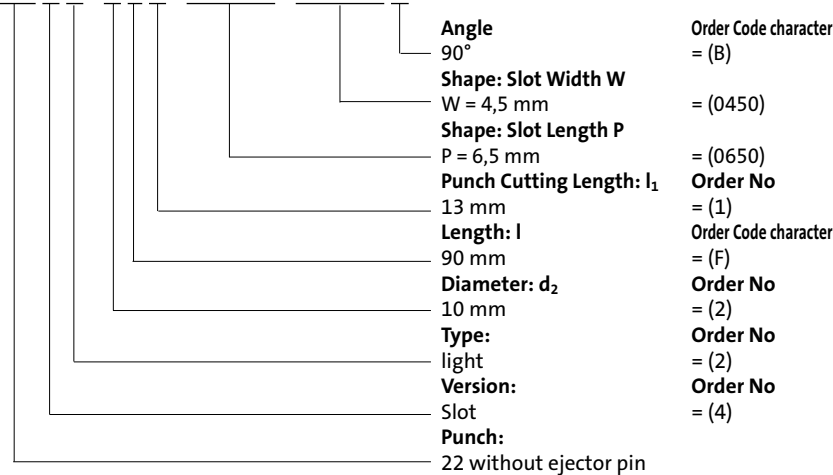

Material:

HSS
hardened: 62 ± 2 HRC

Execution:

Shaft and punch shape fine ground.

Ordering example:

Synopsis see fold out page E31

FIBRO

2702.

Ball-Lock Punches
blank with ejector pin, light duty

Material:

HSS
hardened: 62 ± 2 HRC

Execution:

Shaft fine ground.

Ordering example:

Synopsis see fold out page E31

2702. Version: Blank (0)

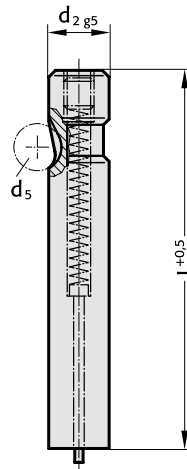

2702.

d_2 / (Order No)	d_5	l / (Order Code character)				
		63 (C)	71 (D)	80 (E)	90 (F)	100 (G)
6 (1)	6	●	●	●	●	●
10 (2)	8	●	●	●	●	●
13 (3)	8	●	●	●	●	●
16 (4)	8	●	●	●	●	●
20 (5)	8	●	●	●	●	●
25 (6)	8	●	●	●	●	●
32 (7)	8		●	●	●	●
38 (8)	8			●	●	●

Other lengths on request

Ordering example:

2702.7G

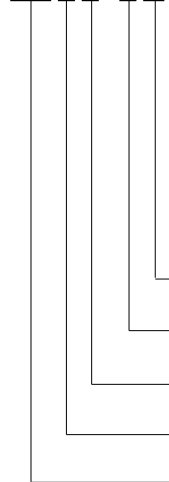

Length: l
100 mm
Diameter: d_2
32 mm
Type:
light
Version:
Blank
Punch:
with ejector pin (27)

Order Code character
= (G)
Order No
= (7)
Order No
= (2)
Order No
= (0)

Ball-Lock Punches stepped with ejector pin, light duty

FIBRO

2712.



2712. Version: Rund (1)

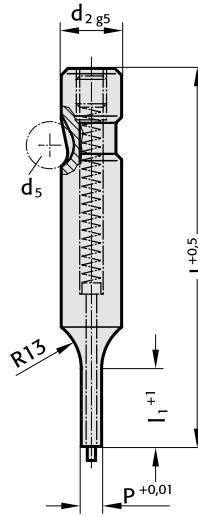

Material:

HSS
hardened: 62 ± 2 HRC

Execution:

Shaft and punch diameter fine ground.

Ordering example:

Synopsis see fold out page E31

2712.

d ₂ / (Order No)	d ₅	P	l ₁ / (Order No)	l / (Order Code character)				
				63 (C)	71 (D)	80 (E)	90 (F)	100 (G)
6 (1)	6	1,6 - 5,9	13* (1)	●	●	●	●	●
10 (2)	8	1,6 - 9,9	13* (1) 19* (2)	●	●	●	●	●
13 (3)	8	5,0-12,9	13 (1) 19 (2)	●	●	●	●	●
16 (4)	8	8,0-15,9	13 (1) 19 (2) 25 (3)	●	●	●	●	●
20 (5)	8	12,0-19,9	13 (1) 19 (2) 25 (3)	●	●	●	●	●
25 (6)	8	16,0-24,9	13 (1) 19 (2) 25 (3)	●	●	●	●	●
32 (7)	8	24,0-31,9	13 (1) 19 (2) 25 (3)		●	●	●	●
38 (8)	8	30,0-37,9	19 (2) 25 (3) 30 (4)			●	●	●

* l₁ = 10 where P < 2,20

Other lengths on request

Ordering example:

2 7 1 2 . 7 G 2 . 2 4 5 0

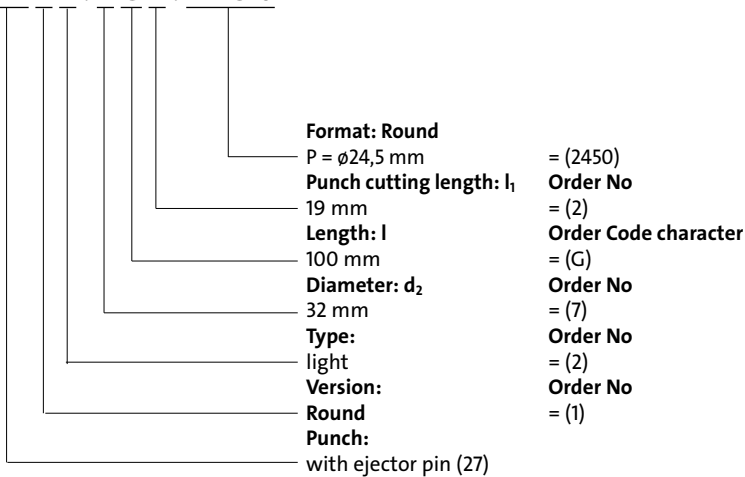

FIBRO

2722. 2732.
2742. 2752.

Ball-Lock Punches, stepped with ejector pin, light duty

2722. Version: Square (2)

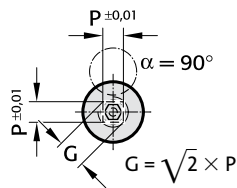

2732. Version: Rectangular (3)

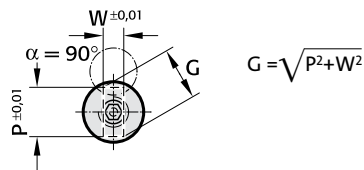

2742. Version: Slot (4)

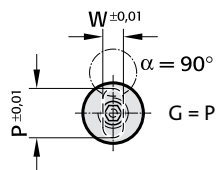

2752. Rectangle with radiused corners (5)

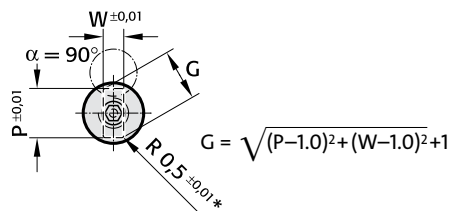

* For other radius options, see standardised special shapes, pages E 100 – E 101.



2722./ 2732./ 2742. / 2752.

d ₂ / (Order No)	d ₅	W _{min.}	G _{max.}	l ₁ / (Order No)	l / (Order Code character)				
					63 (C)	71 (D)	80 (E)	90 (F)	100 (G)
6 (1)	6	1,6	5,9	13* (1)	●	●	●	●	●
10 (2)	8	1,6	9,9	13* (1) 19* (2)	●	●	●	●	●
13 (3)	8	4,5	12,9	13 (1) 19 (2)	●	●	●	●	●
16 (4)	8	6,0	15,9	13 (1) 19 (2) 25 (3)	●	●	●	●	●
20 (5)	8	8,0	19,9	13 (1) 19 (2) 25 (3)	●	●	●	●	●
25 (6)	8	10,0	24,9	13 (1) 19 (2) 25 (3)	●	●	●	●	●
32 (7)	8	12,5	31,9	13 (1) 19 (2) 25 (3)		●	●	●	●
38 (8)	8	14,0	37,9	19 (2) 25 (3) 30 (4)			●	●	●

*l₁ = 10 where P or W < 2,20

Other lengths on request

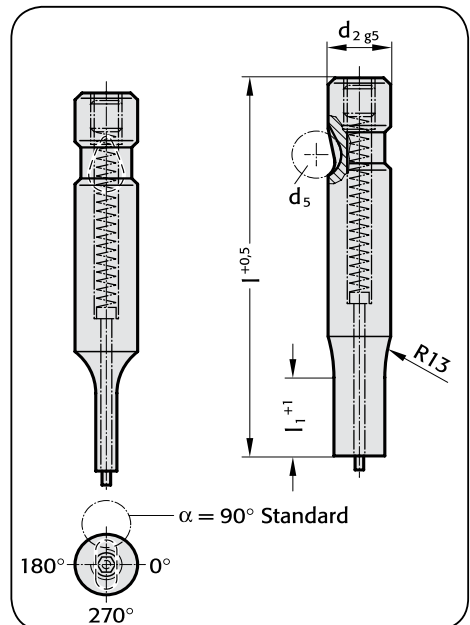

Ordering example:

2742.2F1.0650.0450B

Angle 90°
 Format: Slot, width W
 W = 4,5 mm
 Format: Slot, length P
 P = 6,5 mm
 Punch cutting length: l₁
 13 mm
 Length: l
 90 mm
 Diameter: d₂
 10 mm
 Type: light
 Version: Slot
 Punch: with ejector pin (27)

Order Code character = (B)
 = (0450)
 = (0650)
 Order No = (1)
 Order Code character = (F)
 Order No = (2)
 Order No = (2)
 Order No = (4)

Material:

HSS
 hardened: 62 ± 2 HRC

Execution:

Shaft and punch shape fine ground.

Ordering example:

Synopsis see fold out page E31

FIBRO

Ball-Lock Punches
punch larger than shaft,
light duty

2214.

Material:

HSS
hardened: 62 ± 2 HRC

Execution:

Shaft and punch diameter fine ground.

Ordering example:

Synopsis see fold out page E31

2214. Version: Round (1)

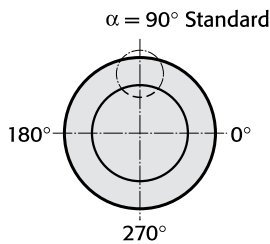
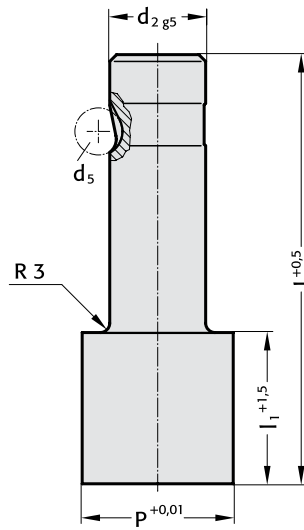

2214.

d ₂ / (Order No)	d ₅	P	l ₁ / (Order No)	l / (Order Code character)			
				80 (E)	90 (F)	100 (G)	
13 (3)	8	13,1-32,0	19 (2)	30 (4)	●	●	●
16 (4)	8	16,1-38,0	19 (2)	30 (4)	●	●	●
20 (5)	8	20,1-40,0	19 (2)	30 (4)	●	●	●
25 (6)	8	25,1-44,0	19 (2)	30 (4)	●	●	●
32 (7)	8	32,1-50,0	19 (2)	30 (4)	●	●	●

Other lengths on request

Ordering example:

2 2 1 4 . 7 G 2 . 3 2 1 0

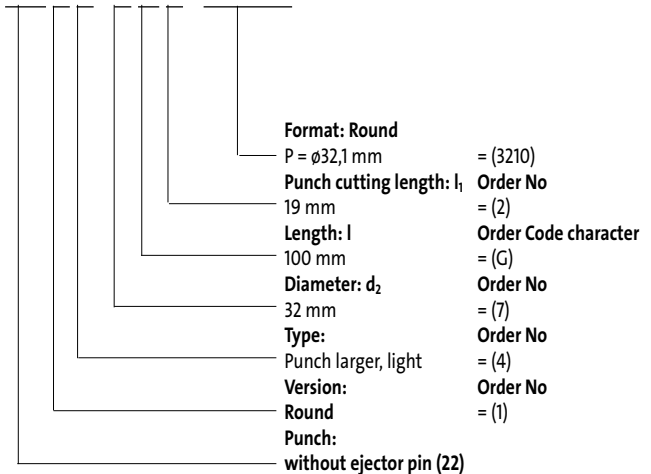

Ball-Lock Punches,, punch larger than shaft, light duty

FIBRO

2224. 2234.
2244. 2254.



2224. Version: Square (2)

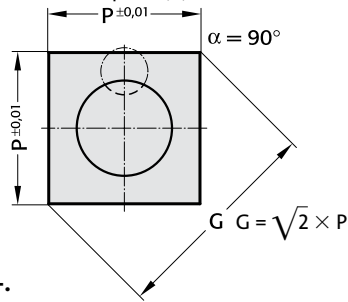

2234. Version: Rectangular (3)

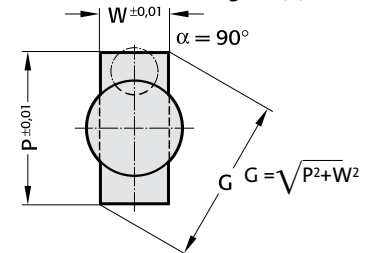

2244. Version: Slot (4)

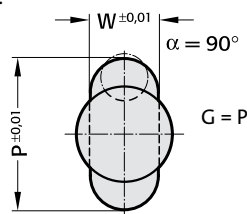

2254. Version: Rectangle with radiused corners (5)

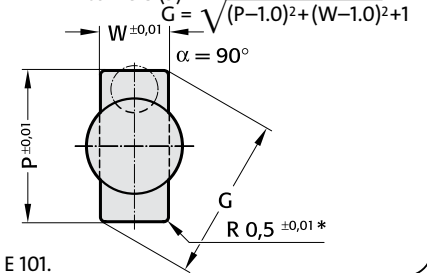

* For other radius options, see standardised special shapes, pages E 100 – E 101.

2224./ 2234./ 2244. / 2254.

d ₂ / (Order No)	d ₅	W _{min.}	G _{max.}	l ₁ / (Order No)	l / (Order Code character)		
					80 (E)	90 (F)	100 (G)
13 (3)	8	5,0	32,0	19 (2) 30 (4)	●	●	●
16 (4)	8	6,5	38,0	19 (2) 30 (4)	●	●	●
20 (5)	8	8,0	40,0	19 (2) 30 (4)	●	●	●
25 (6)	8	10,0	44,0	19 (2) 30 (4)	●	●	●
32 (7)	8	11,5	50,0	19 (2) 30 (4)	●	●	●

Other lengths on request

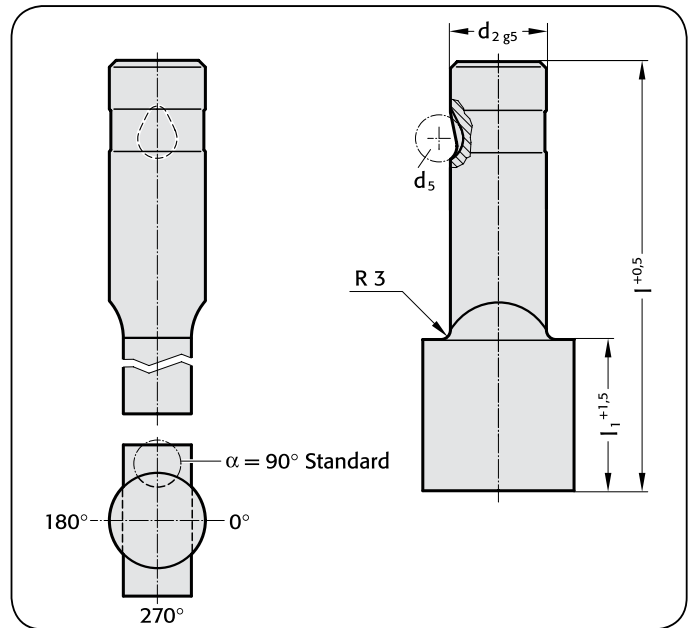

Ordering example:

2 2 3 4 . 7 F 2 . 3 8 0 0 . 1 1 5 0 B

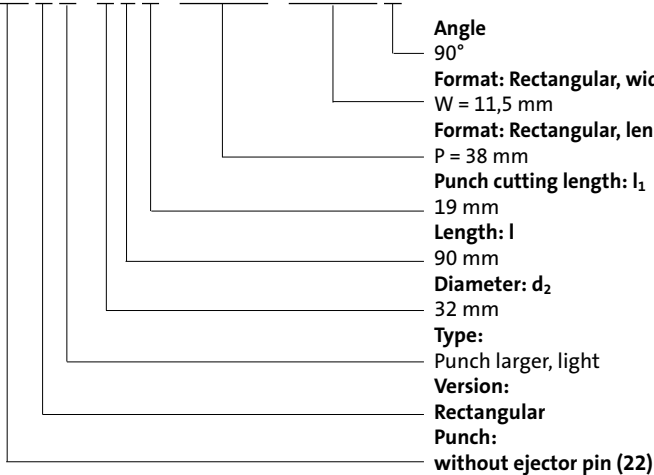

Order Code character = (B)
Format: Rectangular, width W = (1150)
Format: Rectangular, length P = (3800)
Punch cutting length: l₁ = (2)
Length: l = (F)
Diameter: d₂ = (7)
Type: Punch larger, light = (4)
Version: Rectangular = (3)
Punch: without ejector pin (22)

Material:

HSS
hardened: 62 ± 2 HRC

Execution:

Shaft and punch shape fine ground.

Ordering example:

Synopsis see fold out page E31

FIBRO

2704.

**Ball-Lock Punches,
punch larger than shaft,
light duty with ejector pin**

Material:

HSS
hardened: 62 ± 2 HRC

Execution:

Shaft and punch diameter fine ground.

Ordering example:

Synopsis see fold out page E31

2704. Version: Blank (0)

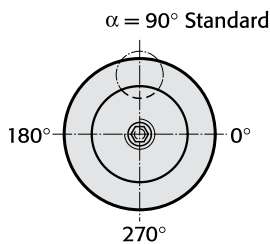
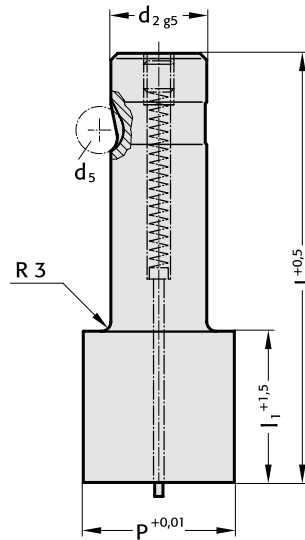

2704.

d ₂ / (Order No)	d ₅	P	l ₁ / (Order No)		l / (Order Code character)		
					80 (E)	90 (F)	100 (G)
13 (3)	8	32,0	19 (2)	30 (4)	●	●	●
16 (4)	8	38,0	19 (2)	30 (4)	●	●	●
20 (5)	8	40,0	19 (2)	30 (4)	●	●	●
25 (6)	8	44,0	19 (2)	30 (4)	●	●	●
32 (7)	8	50,0	19 (2)	30 (4)	●	●	●

Other lengths on request

Ordering example:

2704.4F4.3800

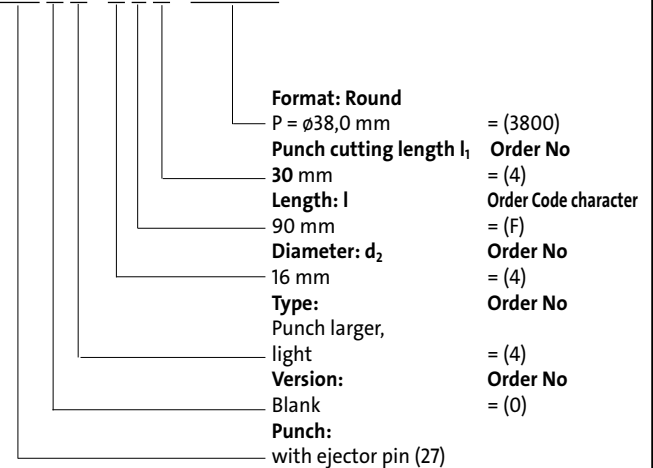

FIBRO

2724. 2734.
2744. 2754.

Ball-Lock Punches,
punch larger than shaft,
light duty with ejector pin

2724.

Version:
Square (2)

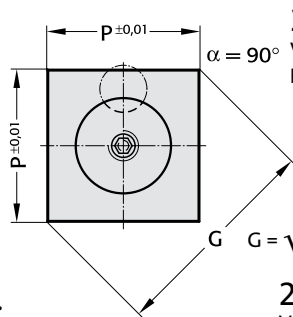

2734.

Version:
Rectangular
(3)

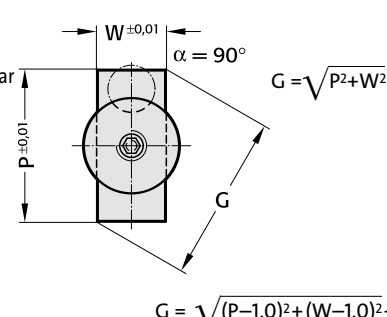

2744.

Version:
Slot (4)

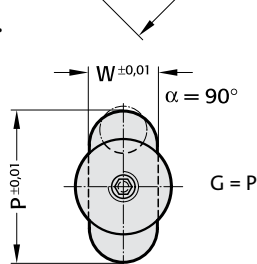

2754.

Version:
Rectangle
with radiused
corners (5)

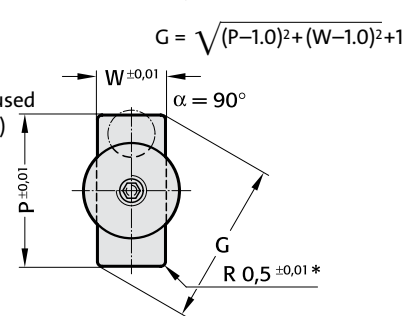

* For other radius options,
see standardised special shapes, pages E 100 – E 101.



2724./ 2734./ 2744. / 2754.

d ₂ / (Order No)	d ₅	W _{min.}	G _{max.}	l ₁ / (Order No)	l / (Order Code character)		
					80 (E)	90 (F)	100 (G)
13 (3)	8	5,0	32,0	19 (2) 30 (4)	●	●	●
16 (4)	8	6,5	38,0	19 (2) 30 (4)	●	●	●
20 (5)	8	8,0	40,0	19 (2) 30 (4)	●	●	●
25 (6)	8	10,0	44,0	19 (2) 30 (4)	●	●	●
32 (7)	8	11,5	50,0	19 (2) 30 (4)	●	●	●

Other lengths on request

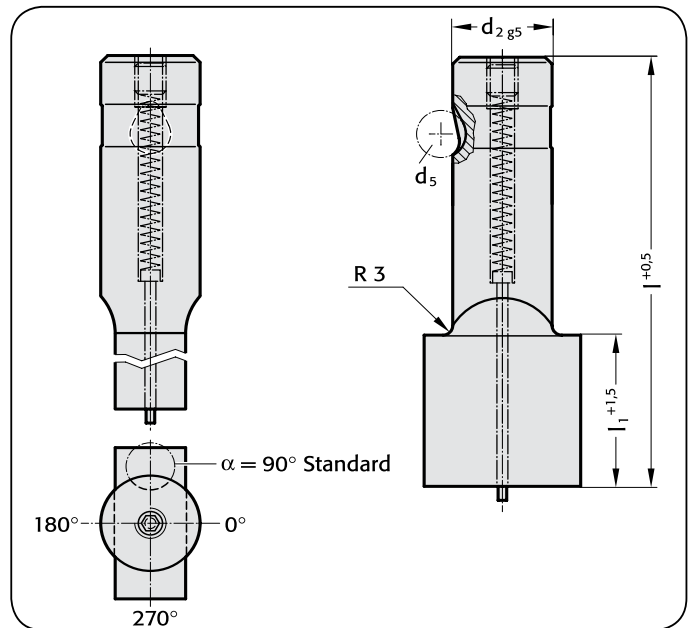

Ordering example:

2 7 3 4 . 7 F 2 . 3 8 0 0 . 1 1 5 0 B

Angle
90°
Order Code character
= (B)

Format: Rectangular, width W
W = 11,5 mm
= (1150)

Format: Rectangular, length P
P = 38 mm
= (3800)

Punch cutting length: l₁
19 mm
Order No
= (2)

Length: l
90 mm
Order Code character
= (F)

Diameter: d₂
32 mm
Order No
= (7)

Type:
Punch larger, light
Order No
= (4)

Version:
Rectangular
Order No
= (3)

Punch:
with ejector pin (27)

Material:

HSS
hardened: 62 ± 2 HRC

Execution:

Shaft and punch shape fine ground.

Ordering example:

Synopsis see fold out page E31

Ball-Lock Pilot Pins,
with tapered tip, light duty

2262.



2262. Version: Pilot pin with tapered tip (6)

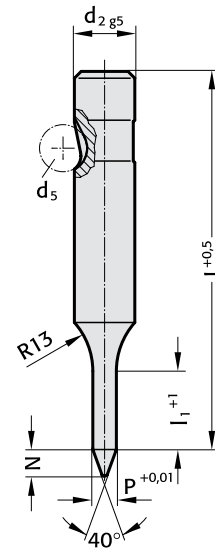

2262.

d ₂ / (Order No)	d ₅	P	I ₁ / (Order No)	N	I / (Order Code character)								
					71 (D)	80 (E)	90 (F)	100 (G)	110 (H)	125 (J)	140 (K)	150 (L)	
10 (2)	8	5,9- 9,9	19 (2)	8	●	●	●	●	●				
13 (3)	8	9,9-12,9	19 (2)	10	●	●	●	●	●	●			
16 (4)	8	12,9-15,9	25 (3)	15	●	●	●	●	●	●	●		●
20 (5)	8	15,9-19,9	25 (3)	20	●	●	●	●	●	●	●	●	●
25 (6)	8	19,9-24,9	25 (3)	25	●	●	●	●	●	●	●	●	●
32 (7)	8	24,9-31,9	25 (3)	30		●	●	●	●	●	●	●	●
38 (8)	8	31,9-37,9	30 (4)	35		●	●	●	●	●	●	●	●

Other lengths on request

Ordering example:

2 2 6 2 . 4 G 3 . 1 4 0 0

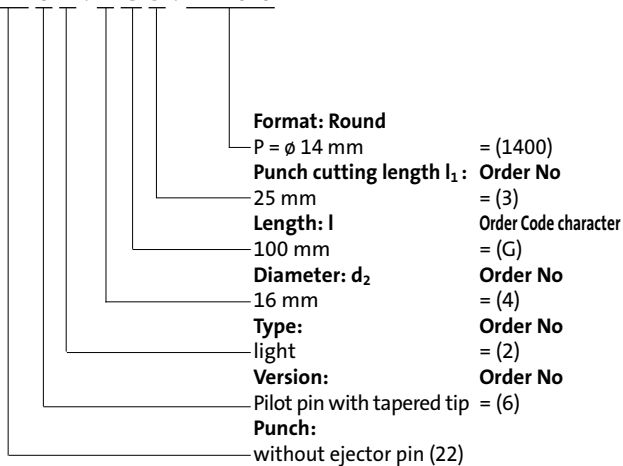

Material:

HSS
hardened: 62 ± 2 HRC

Execution:

Shaft and pilot pin fine ground.

Ordering example:

Synopsis see fold out page E31

FIBRO

2272.

Ball-Lock Pilot Pins, with parabolic tip, light duty

2272. Version: Pilot pin parabolic tip (7)

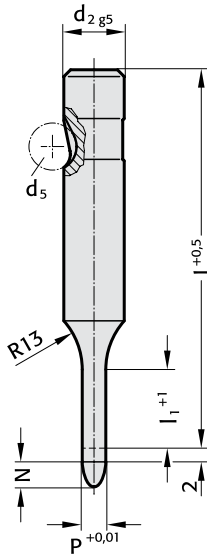

2272.

d ₂ / (Order No)	d ₅	P	l ₁ / (Order No)	l / (Order Code character)						
				50 (A)	56 (B)	63 (C)	71 (D)	80 (E)	90 (F)	100 (G)
6 (1)	6	2,9- 5,9	13 (1)	●	●	●	●	●	●	●
10 (2)	8	5,9- 9,9	19 (2)	●	●	●	●	●	●	●
13 (3)	8	9,9-12,9	19 (2)	●	●	●	●	●	●	●
16 (4)	8	12,9-15,9	25 (3)			●	●	●	●	●
20 (5)	8	15,9-19,9	25 (3)			●	●	●	●	●
25 (6)	8	19,9-24,9	25 (3)			●	●	●	●	●
32 (7)	8	24,9-31,9	25 (3)				●	●	●	●
38 (8)	8	31,9-37,9	30 (4)					●	●	●

Other lengths on request

Ordering example:
2 2 7 2 . 4 G 3 . 1 4 0 0

Format: Round
P = ø 14 mm = (1400)
Punch cutting length l₁: 25 mm = (3)
Order No = (3)
Length: l 100 mm = (G)
Order Code character = (G)
Diameter: d₂ 16 mm = (4)
Order No = (4)
Type: light = (2)
Order No = (2)
Version: Pilot pin parabolic tip = (7)
Order No = (7)
Punch: without ejector pin (22)

Material:

HSS
hardened: 62 ± 2 HRC

Execution:

Shaft and pilot pin fine ground.

„l“ length of pilot pin is without tip

Note: The 2 mm length provides full guidance before the blanking punch contacts the sheet metal.

	P	N
	≤ 10 mm	8 mm
10,1 mm	- 15 mm	12 mm
	> 15 mm	15 mm

Ordering example:

Synopsis see fold out page E31

Ball-Lock Punches,
blank, heavy duty

2203.

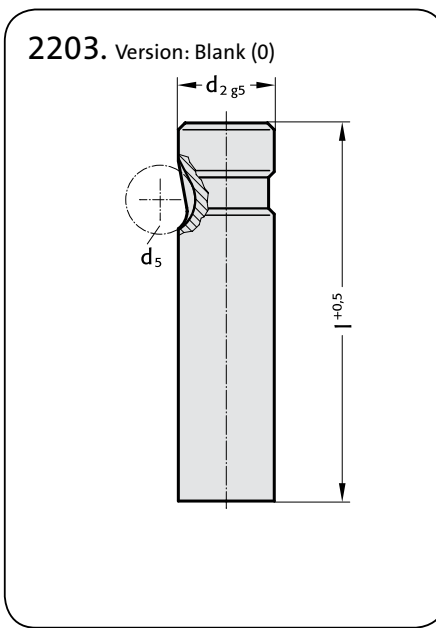

Material:

HSS
hardened: 62 ± 2 HRC

Execution:

Shaft fine ground.

Ordering example:

Synopsis see fold out page E31

2203.

d ₂ / (Order No)	d ₅	l / (Order Code character)											
		63 (C)	71 (D)	80 (E)	90 (F)	100 (G)	110 (H)	125 (J)	140 (K)	150 (L)	175 (M)	200 (N)	
10 (2)	10	●	●	●	●	●	●	●					
13 (3)	12	●	●	●	●	●	●	●	●	●			
16 (4)	12	●	●	●	●	●	●	●	●	●	●		
20 (5)	12	●	●	●	●	●	●	●	●	●	●	●	
25 (6)	12		●	●	●	●	●	●	●	●	●	●	●
32 (7)	12		●	●	●	●	●	●	●	●	●	●	●
40 (9)	12			●	●	●	●	●	●	●	●	●	●

Other lengths on request

Ordering example:

2203.7G

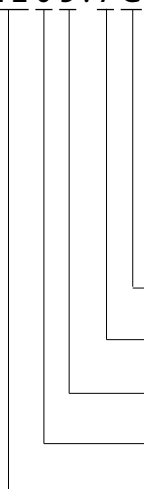

Length: l
100 mm
Diameter: d₂
32 mm
Type:
heavy
Version:
Blank
Punch:
without ejector pin (22)

Order Code character
= (G)
Order No
= (7)
Order No
= (3)
Order No
= (0)

FIBRO

2213.

Ball-Lock Punches, stepped, heavy duty

Material:

HSS
hardened: 62 ± 2 HRC

Execution:

Shaft and punch diameter fine ground.

2213. Version: Round (1)

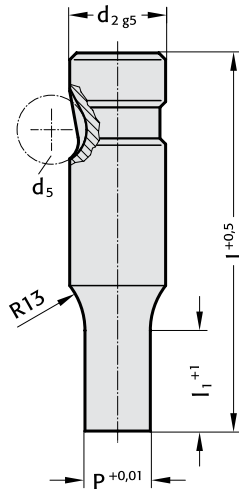

Ordering example:

Synopsis see fold out page E31

2213.

d ₂ / (Order No)	d ₅	P	l ₁ / (Order No)	l / (Order Code character)						
				63 (C)	71 (D)	80 (E)	90 (F)	100 (G)	110 (H)	125 (J)
10 (2)	10	1,6- 9,9	13* (1) 19*(2)	●	●	●	●	●	●	●
13 (3)	12	5,0-12,9	13 (1) 19 (2)	●	●	●	●	●	●	●
16 (4)	12	8,0-15,9	13 (1) 19 (2) 25 (3)	●	●	●	●	●	●	●
20 (5)	12	12,0-19,9	13 (1) 19 (2) 25 (3)	●	●	●	●	●	●	●
25 (6)	12	16,0-24,9	13 (1) 19 (2) 25 (3)		●	●	●	●	●	●
32 (7)	12	24,0-31,9	13 (1) 19 (2) 25 (3)		●	●	●	●	●	●
40 (9)	12	30,0-39,9	19 (2) 25 (3) 30 (4)			●	●	●	●	●

* l₁ = 10 where P < 2,20

Other lengths on request

Ordering example:

2 2 1 3 . 7 G 2 . 2 4 5 0

Format: Round
 P = ø24,5 mm
Punch cutting length: l₁
 19 mm
Length: l
 100 mm
Diameter: d₂
 32 mm
Type:
 heavy
Version:
 Round
Punch:
 without ejector pin (22)

= (2450)
Order No
 = (2)
Order Code character
 = (G)
Order No
 = (7)
Order No
 = (3)
Order No
 = (1)

**Ball-Lock Punches,
stepped, heavy duty**

2223. 2233.
2243. 2253.



2223. Version: Square (2)

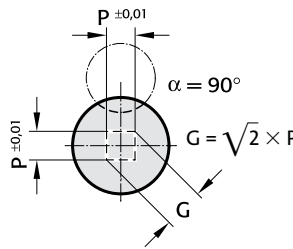

2233. Version: Rectangular (3)

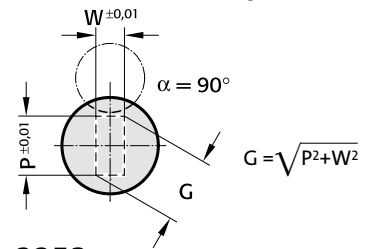

2243. Version: Slot (4)

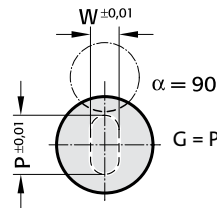

2253. Version: Rectangle with radiused corners (5)

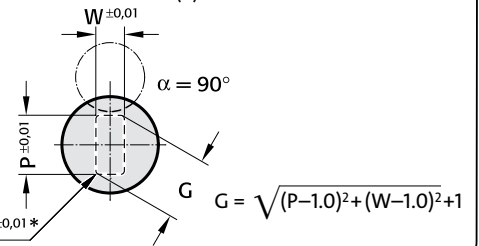

* For other radius options, see standardised special shapes, pages E 100 – E 101.

2223./ 2233./ 2243. / 2253.

d ₂ / (Order No)	d ₅	W _{min.}	G _{max.}	l ₁ / (Order No)	l / (Order Code character)						
					63 (C)	71 (D)	80 (E)	90 (F)	100 (G)	110 (H)	125 (J)
10 (2)	10	1,6	9,9	13* (1) 19* (2)	●	●	●	●	●	●	●
13 (3)	12	4,5	12,9	13 (1) 19 (2)	●	●	●	●	●	●	●
16 (4)	12	6,0	15,9	13 (1) 19 (2) 25 (3)	●	●	●	●	●	●	●
20 (5)	12	8,0	19,9	13 (1) 19 (2) 25 (3)	●	●	●	●	●	●	●
25 (6)	12	10,0	24,9	13 (1) 19 (2) 25 (3)	●	●	●	●	●	●	●
32 (7)	12	12,5	31,9	13 (1) 19 (2) 25 (3)	●	●	●	●	●	●	●
40 (9)	12	14,0	39,9	19 (2) 25 (3) 30 (4)	●	●	●	●	●	●	●

*l₁ = 10 where P or W < 2,20

Other lengths on request

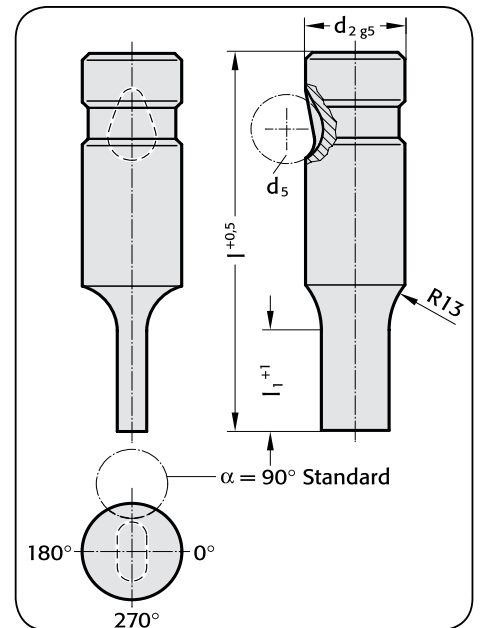

Ordering example:

2 2 4 3 . 3 E 2 . 1 2 1 5 . 0 9 1 5 B

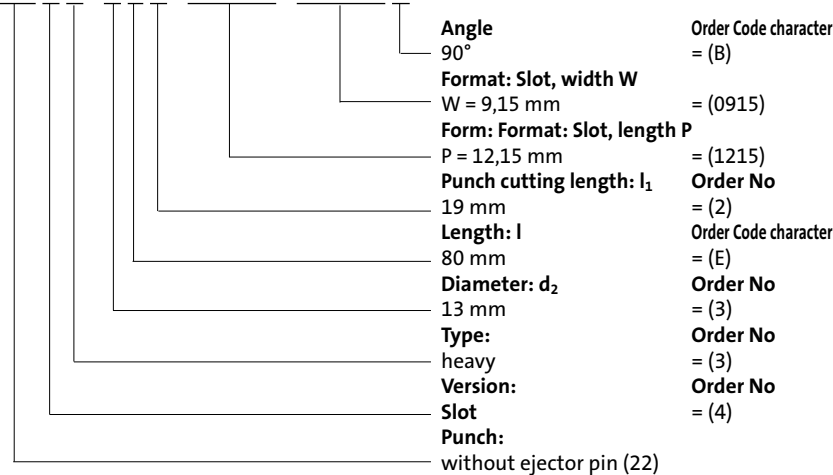

Material:

HSS
hardened: 62 ± 2 HRC

Execution:

Shaft and punch shape fine ground.

Ordering example:

Synopsis see fold out page E31

FIBRO

**Ball-Lock Punches
blank with ejector pin,
heavy duty**

2703.

Material:

HSS
hardened: 62 ± 2 HRC

Execution:

Shaft fine ground.

Ordering example:

Synopsis see fold out page E31

2703. Version: Blank (0)

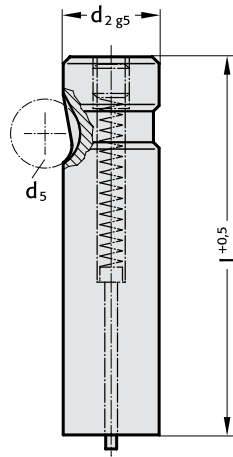

2703.

d_2 / (Order No)	d_5	l / (Order Code character)						
		63 (C)	71 (D)	80 (E)	90 (F)	100 (G)	110 (H)	125 (J)
10 (2)	10	●	●	●	●	●		
13 (3)	12	●	●	●	●	●	●	●
16 (4)	12	●	●	●	●	●	●	●
20 (5)	12	●	●	●	●	●	●	●
25 (6)	12		●	●	●	●	●	●
32 (7)	12		●	●	●	●	●	●
40 (9)	12			●	●	●	●	●

Other lengths on request

Ordering example:

2703.7G

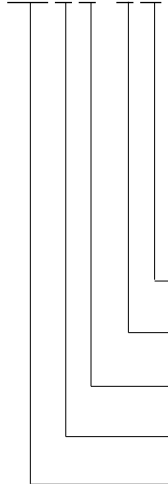

Length: l
100 mm
Diameter: d_2
32 mm
Type:
heavy
Version:
Blank
Punch:
with ejector pin (27)

Order Code character
= (G)
Order No
= (7)
Order No
= (3)
Order No
= (0)

Ball-Lock Punches stepped with ejector pin, heavy duty

FIBRO

2713.

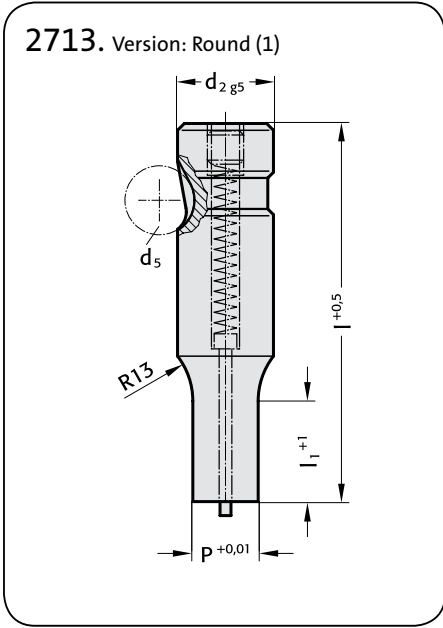

Material:

HSS
hardened: 62 ± 2 HRC

Execution:

Shaft and punch diameter fine ground.

Ordering example:

Synopsis see fold out page E31

2713.

d ₂ / (Order No)	d ₅	P	l ₁ / (Order No)		l / (Order Code character)						
					63 (C)	71 (D)	80 (E)	90 (F)	100 (G)	110 (H)	125 (J)
10 (2)	10	1,6- 9,9	13* (1)	19* (2)	●	●	●	●	●		
13 (3)	12	5,0-12,9	13 (1)	19 (2)	●	●	●	●	●	●	●
16 (4)	12	8,0-15,9	13 (1)	19 (2)	25 (3)	●	●	●	●	●	●
20 (5)	12	12,0-19,9	13 (1)	19 (2)	25 (3)	●	●	●	●	●	●
25 (6)	12	16,0-24,9	13 (1)	19 (2)	25 (3)		●	●	●	●	●
32 (7)	12	24,0-31,9	13 (1)	19 (2)	25 (3)		●	●	●	●	●
40 (9)	12	30,0-39,9	19 (2)	25 (3)	30 (4)			●	●	●	●

* l₁ = 10 where P < 2,20

Other lengths on request

Ordering example:

2713.3C1.0550

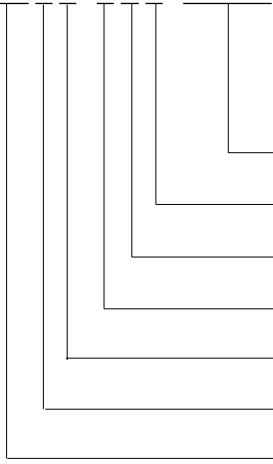

Format: Round
P = ø5,5 mm
Punch cutting length: l₁
13 mm
Length: l
63 mm
Diameter: d₂
13 mm
Type:
heavy
Version:
Round
Punch:
with ejector pin (27)

= (0550)
Order No
= (1)
Order Code character
= (C)
Order No
= (3)
Order No
= (3)
Order No
= (1)

FIBRO

**Ball-Lock Punches,
punch larger than shaft,
heavy duty**

2215.

Material:

HSS
hardened: 62 ± 2 HRC

Execution:

Shaft and punch diameter fine ground.

Ordering example:

Synopsis see fold out page E31

2215. Version: Round (1)

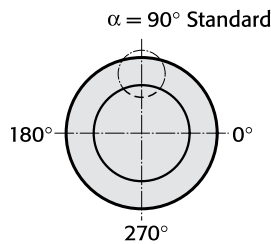
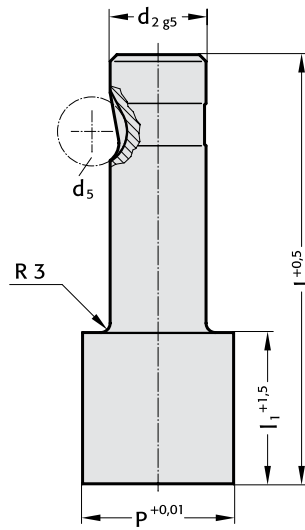

2215.

d_2 / (Order No)	d_5	P	l_1 / (Order No)	30 (4)	l / (Order Code character)		
					80 (E)	90 (F)	100 (G)
13 (3)	12	13,1-32,0	19 (2)	30 (4)	●	●	●
16 (4)	12	16,1-38,0	19 (2)	30 (4)	●	●	●
20 (5)	12	20,1-40,0	19 (2)	30 (4)	●	●	●
25 (6)	12	25,1-44,0	19 (2)	30 (4)	●	●	●
32 (7)	12	32,1-50,0	19 (2)	30 (4)	●	●	●
40 (9)	12	40,1-56,0	19 (2)	30 (4)	●	●	●

Other lengths on request

Ordering example:

2 2 1 5 . 7 G 2 . 3 2 1 0

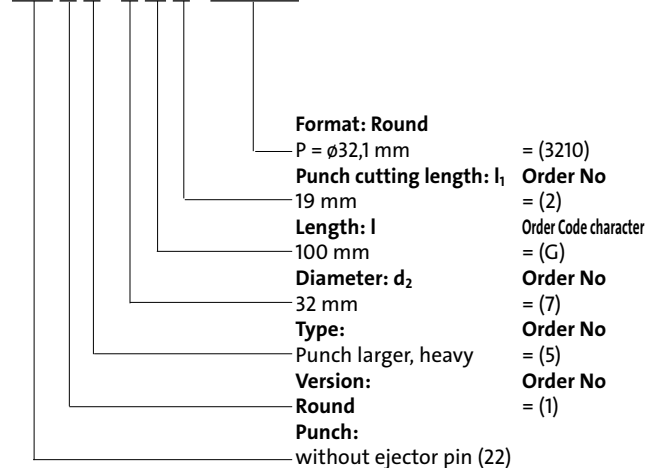

Ball-Lock Punches, punch larger than shaft, heavy duty

FIBRO

2225. 2235.
2245. 2255.

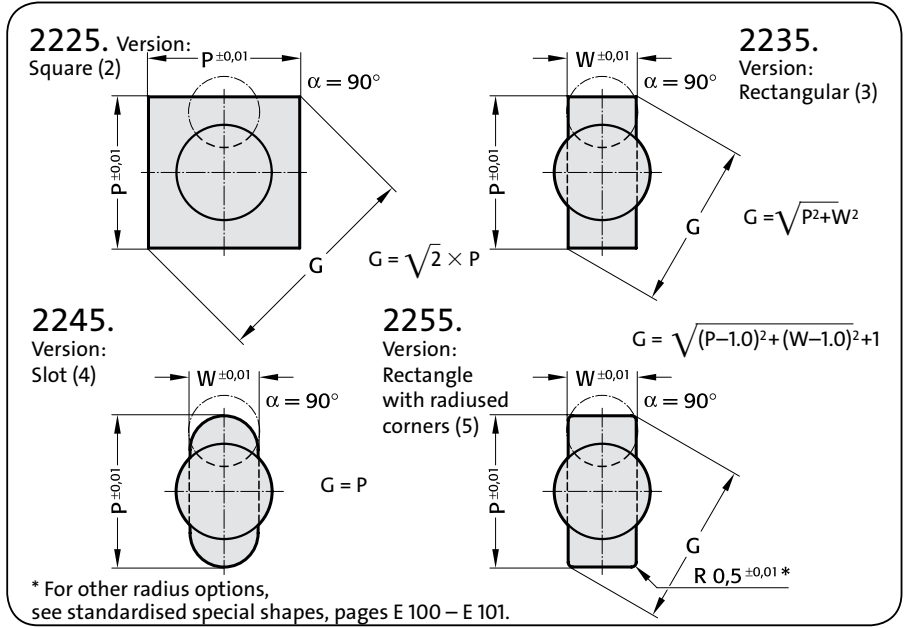

2225./ 2235./ 2245. / 2255.

d_2 / (Order No)	d_5	$W_{min.}$	$G_{max.}$	l_1 / (Order No)	I / (Order Code character)		
					80 (E)	90 (F)	100 (G)
13 (3)	12	5,0	32,0	19 (2) 30 (4)	●	●	●
16 (4)	12	6,5	38,0	19 (2) 30 (4)	●	●	●
20 (5)	12	8,0	40,0	19 (2) 30 (4)	●	●	●
25 (6)	12	10,0	44,0	19 (2) 30 (4)	●	●	●
32 (7)	12	11,5	50,0	19 (2) 30 (4)	●	●	●
40 (9)	12	14,0	56,0	19 (2) 30 (4)	●	●	●

Other lengths on request

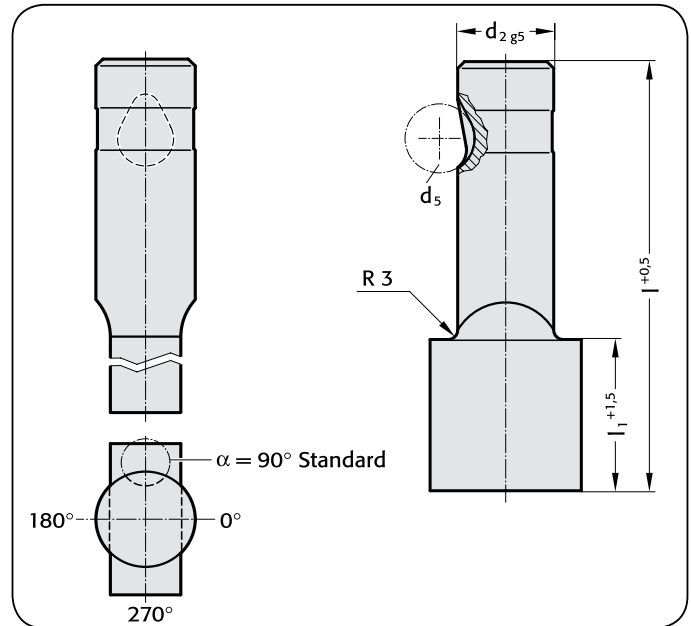

Ordering example:

2 2 3 5 . 4 F 4 . 1 4 0 0 . 1 1 0 0 B

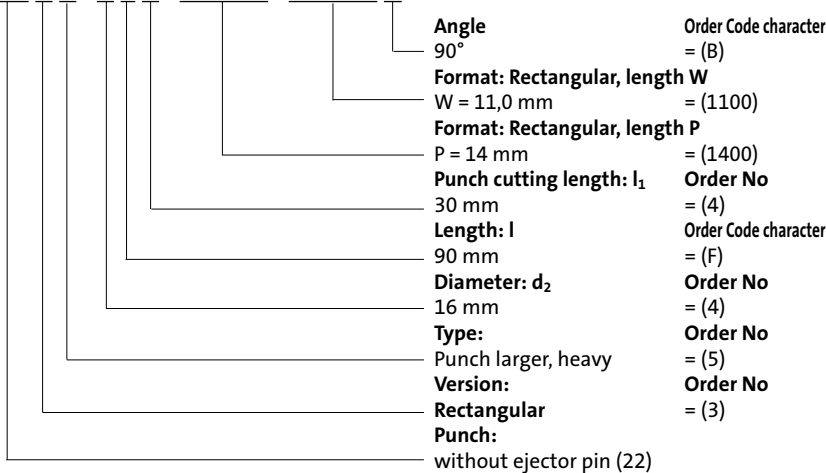

Material:

HSS
hardened: 62 ± 2 HRC

Execution:

Shaft and punch shape fine ground.

Ordering example:

Synopsis see fold out page E31

FIBRO

2705.

**Ball-Lock Punches,
punch larger than shaft,
heavy duty with ejector pin**

Material:

HSS
hardened: 62 ± 2 HRC

Execution:

Shaft and punch diameter fine ground.

Ordering example:

Synopsis see fold out page E31

2705. Version: Blank (0)

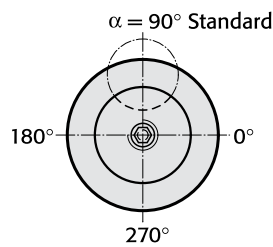
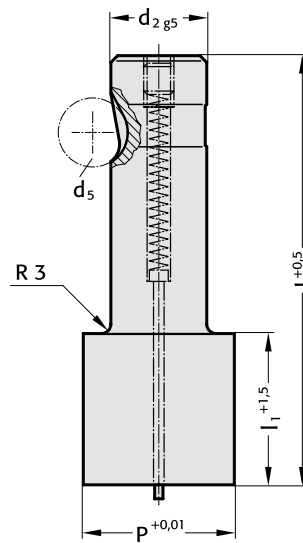

2705.

d ₂ /(Order No)	d ₅	P	l ₁ /(Order No)	l/(Order Code character)			
				80 (E)	90 (F)	100 (G)	
13 (3)	12	32,0	19 (2)	30 (4)	●	●	●
16 (4)	12	38,0	19 (2)	30 (4)	●	●	●
20 (5)	12	40,0	19 (2)	30 (4)	●	●	●
25 (6)	12	44,0	19 (2)	30 (4)	●	●	●
32 (7)	12	50,0	19 (2)	30 (4)	●	●	●
40 (9)	12	56,0	19 (2)	30 (4)	●	●	●

Other lengths on request

Ordering example:

2705.7G4.5000

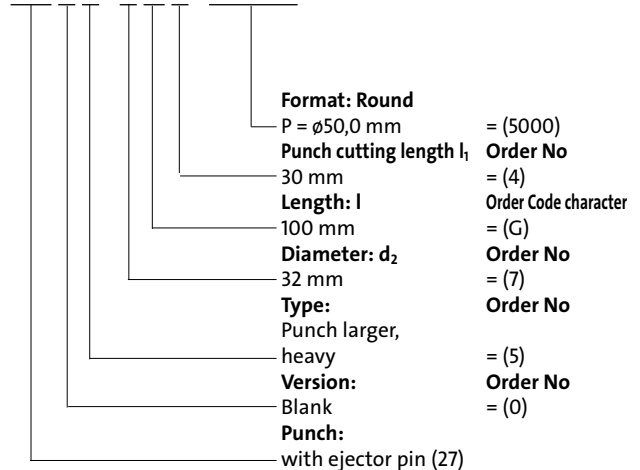

FIBRO

2725. 2735.
2745. 2755.

Ball-Lock Punches, punch larger than shaft, heavy duty with ejector pin

2725.
Version:
Square (2)

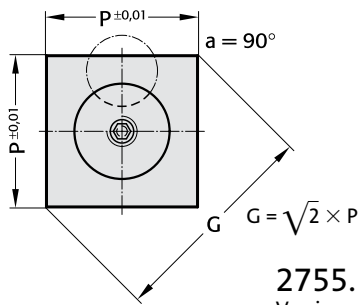

2735.
Version:
Rectangular (3)

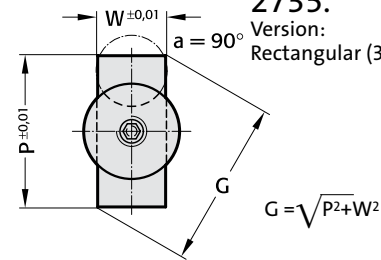

2745.
Version:
Slot (4)

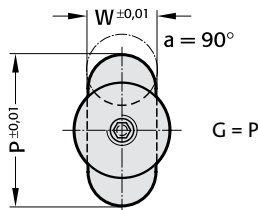

2755.
Version:
Rectangle
with radiused
corners (5)

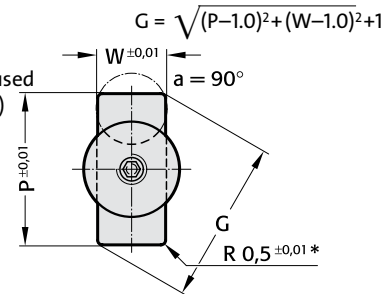

* For other radius options,
see standardised special shapes, pages E 100 – E 101.



2725./ 2735./ 2745. / 2755.

d ₂ / (Order No)	d ₅	W _{min.}	G _{max.}	l ₁ / (Order No)	l / (Order Code character)		
					80 (E)	90 (F)	100 (G)
13 (3)	12	5,0	32,0	19 (2) 30 (4)	●	●	●
16 (4)	12	6,5	38,0	19 (2) 30 (4)	●	●	●
20 (5)	12	8,0	40,0	19 (2) 30 (4)	●	●	●
25 (6)	12	10,0	44,0	19 (2) 30 (4)	●	●	●
32 (7)	12	11,5	50,0	19 (2) 30 (4)	●	●	●
40 (9)	12	14,0	56,0	19 (2) 30 (4)	●	●	●

Other lengths on request

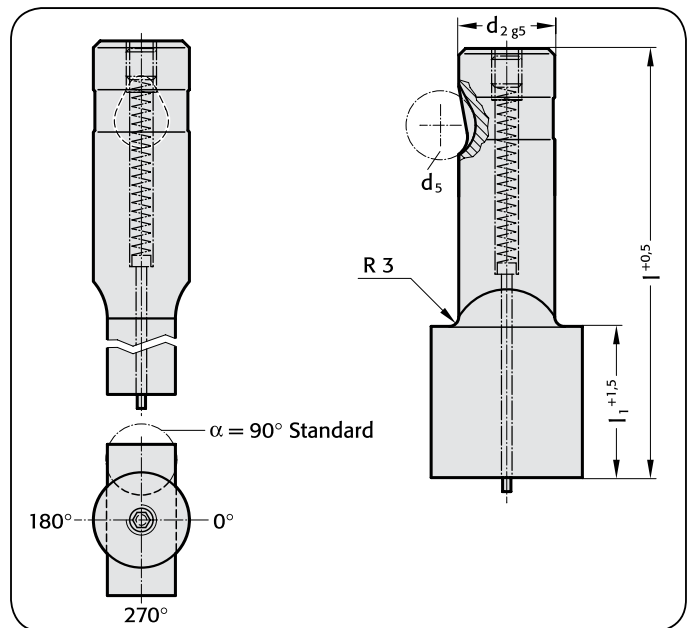

Ordering example:

2735.4F4.1400.1100B

Angle
90°
Order Code character
= (B)
Format: Rectangular, width W
W = 11,0 mm
= (1100)
Format: Rectangular, length P
P = 14,0 mm
= (1400)
Punch cutting length: l₁
30 mm
Order No
= (4)
Length: l
90 mm
Order Code character
= (F)
Diameter: d₂
16 mm
Order No
= (4)
Type:
Punch larger, heavy
Order No
= (5)
Version:
Rectangular
Order No
= (3)
Punch:
with ejector pin (27)

Material:

HSS
hardened: 62 ± 2 HRC

Execution:

Shaft and punch shape fine ground.

Ordering example:

Synopsis see fold out page E31

Ball-Lock Pilot Pins,
with tapered tip, heavy duty

2263.



2263. Version: Pilot pin with tapered tip (6)

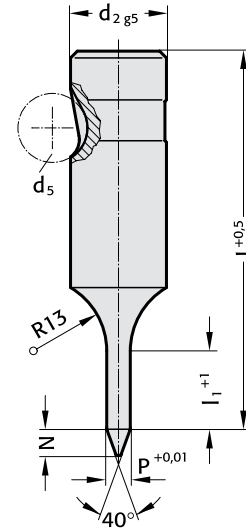

2263.

d ₂ / (Order No)	d ₅	P	l ₁ / (Order No)	N	l / (Order Code character)								
					71 (D)	80 (E)	90 (F)	100 (G)	110 (H)	125 (J)	140 (K)	150 (L)	
10 (2)	10	5,9 - 9,9	19 (2)	8	●	●	●	●	●				
13 (3)	12	9,9 - 12,9	19 (2)	10	●	●	●	●	●	●	●		
16 (4)	12	12,9 - 15,9	25 (3)	15	●	●	●	●	●	●	●	●	
20 (5)	12	15,9 - 19,9	25 (3)	20	●	●	●	●	●	●	●	●	●
25 (6)	12	19,9 - 24,9	25 (3)	25		●	●	●	●	●	●	●	●
32 (7)	12	24,9 - 31,9	25 (3)	30		●	●	●	●	●	●	●	●
40 (9)	12	31,9 - 39,9	30 (4)	40		●	●	●	●	●	●	●	●

Other lengths on request

Ordering example:
2 2 6 3 . 4 G 3 . 1 4 0 0

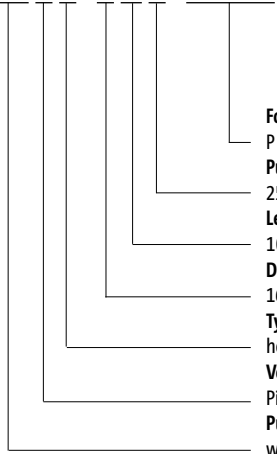

Format: Round
P = ø 14 mm = (1400)
Punch cutting length l₁: 25 mm Order No = (3)
Length: l 100 mm Order Code character = (G)
Diameter: d₂ 16 mm Order No = (4)
Type: heavy Order No = (3)
Version: Pilot pin with tapered tip Order No = (6)
Punch: without ejector pin (22)

Material:

HSS
hardened: 62 ± 2 HRC

Execution:

Shaft and pilot pin fine ground.

Ordering example:

Synopsis see fold out page E31

2273. Version: Pilot pin parabolic tip (7)

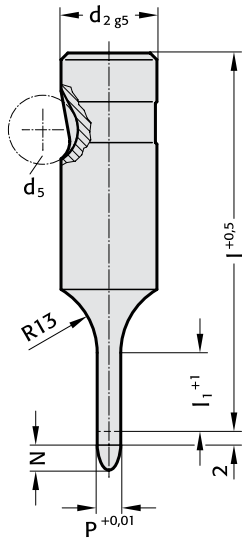

2273.

d ₂ / (Order No)	d ₅	P	l ₁ / (Order No)	l / (Order Code character)						
				63 (C)	71 (D)	80 (E)	90 (F)	100 (G)	110 (H)	125 (J)
10 (2)	10	5,9 - 9,9	19 (2)	●	●	●	●	●		
13 (3)	12	9,9 - 12,9	19 (2)	●	●	●	●	●	●	●
16 (4)	12	12,9 - 15,9	25 (3)	●	●	●	●	●	●	●
20 (5)	12	15,9 - 19,9	25 (3)	●	●	●	●	●	●	●
25 (6)	12	19,9 - 24,9	25 (3)	●	●	●	●	●	●	●
32 (7)	12	24,9 - 31,9	25 (3)		●	●	●	●	●	●
40 (9)	12	31,9 - 39,9	30 (4)			●	●	●	●	●

Other lengths on request

**Ordering example:
2 2 7 3 . 4 G 3 . 1 4 0 0**

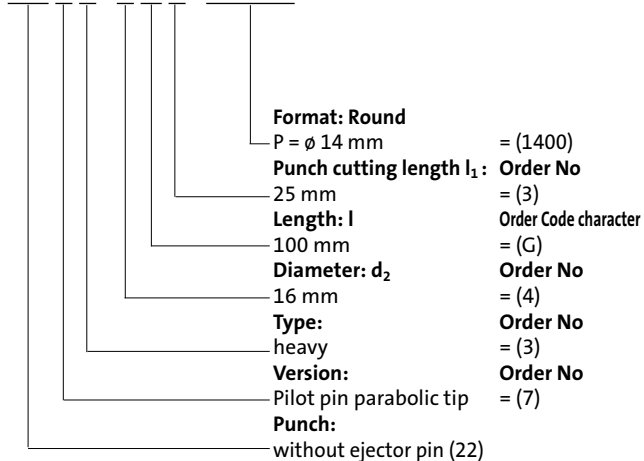

Material:

HSS
hardened: 62 ± 2 HRC

Execution:

„l“ length of pilot pin is without tip
„l“ Length des Suchers ist ohne Spitze
Note: The 2 mm length provides full guidance before the blanking punch contacts the sheet metal.

	P	N
	≤10 mm	8 mm
10,1 mm	- 15 mm	12 mm
	> 15 mm	15 mm

Ordering example:

Synopsis see fold out page E31

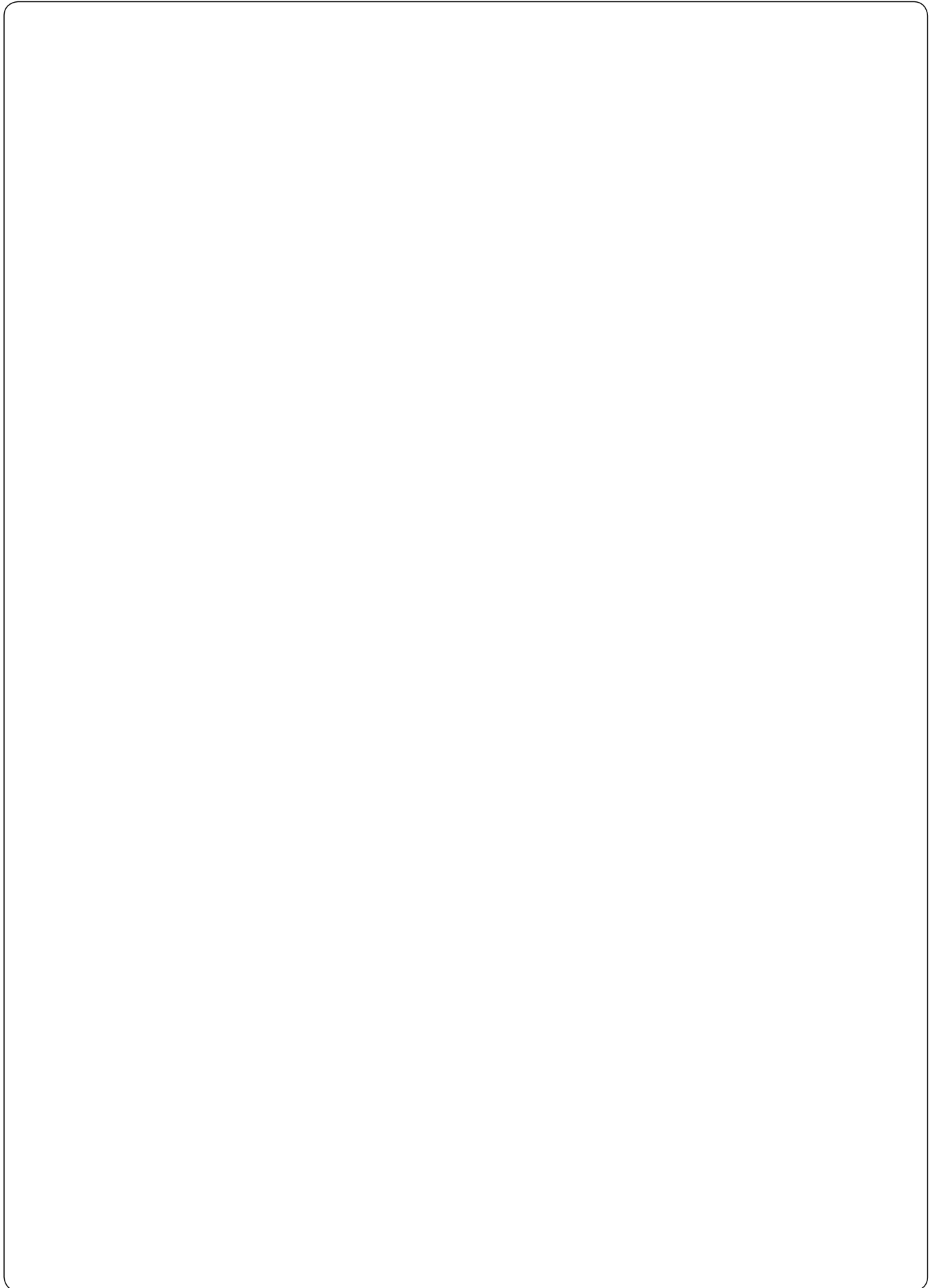

Precision Punches ISO

A large, empty rectangular box with rounded corners, occupying most of the page. It is intended for drawing or writing.

Ordering example Precision Punches ISO 8020

NB: See table for standard dimensions
Special dimensions to order

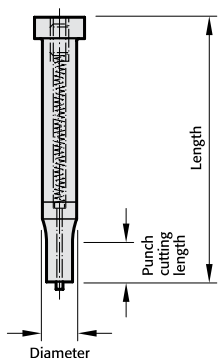

2 2 4 1 . 2 G 4 . 0 6 5 0 . 0 4 5 0 A

Punch:
22 without ejector pin
27 with ejector pin

Punch cutting length: l_1	Order No
8	= 1
10	= 2
13	= 3
19	= 4
25	= 5
30	= 6
special	= x

Format: Slot length P = 6,5 mm

Format: Slot width W = 4,5 mm

Version:	Order No
○ blank	= 0
⊙ round	= 1
□ square	= 2
▭ rectangular	= 3
⬭ slot	= 4
▭ rectangle with radiused corners	= 5
▽ pilot pin with tapered tip	= 6
∩ pilot pin parabolic tip	= 7
special shapes	= 9

Diameter: d_1	Order No
3	= 1
4	= 2
5	= 3
6	= 4
8	= 5
10	= 6
13	= 7
16	= 8
20	= 9
25	= 10
32	= 11

Length: l	Order Code character
50	= A
56	= B
63	= C
71	= D
80	= E
90	= F
100	= G
110	= H
120	= J
125	= K
140	= L
150	= M
200	= N
special	= X

Angle:	Order Code character
0°	= A
90°	= B
180°	= C
270°	= D
special	= X

Type:	Order No
ISO	= 1

Ordering Code (Example):

2241.7G4.0650.0450A

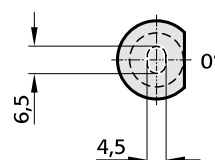
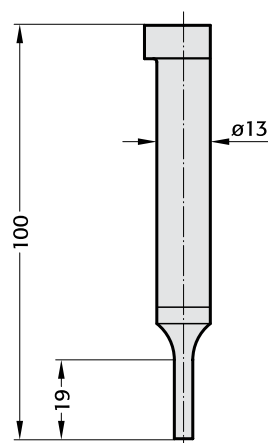
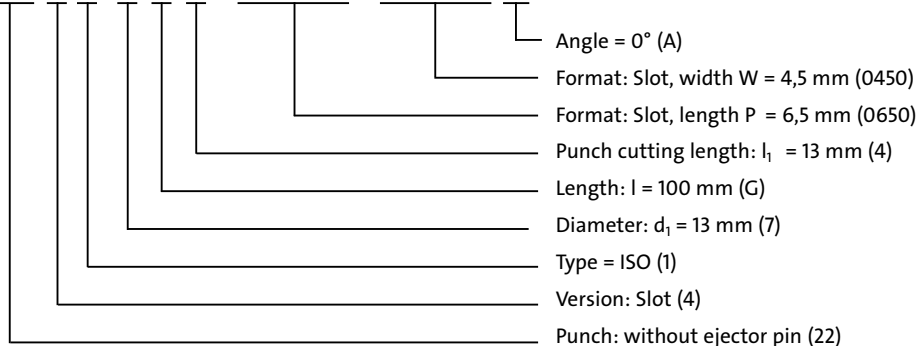

Precision Punches,
blank, ISO 8020

2201.



2201. Version: blank (0)

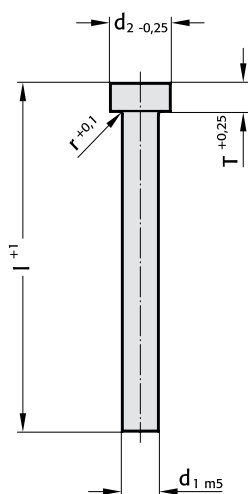

Material:

HSS
Hardness: shaft 64 ± 2 HRC
 head 52 ± 5 HRC

ASP 23 - ASP 2023
Hardness: shaft 64 ± 2 HRC
 head 52 ± 5 HRC

Ordering example: 2201.6D.ASP

Diameter d_1 = 10

Length = 71

(see fold out pages)

Execution:

Punch head hot upset-forged, punch,
shoulder and punch diameter fine ground.

Ordering example:

Synopsis see fold out page E63

2201.

d_1 / (Order No)	d_2	r	T	l / (Order Code character)						
				71 (D)	80 (E)	90 (F)	100 (G)	120 (J)	150 (M)	200 (N)
3 (1)	5	0,25	3	●	●	●	●	●		
4 (2)	6	0,25	3	●	●	●	●	●		
5 (3)	8	0,3	5	●	●	●	●	●		
6 (4)	9	0,3	5	●	●	●	●	●		
8 (5)	11	0,3	5	●	●	●	●	●		
10 (6)	13	0,3	5	●	●	●	●	●	●	
13 (7)	16	0,4	5	●	●	●	●	●	●	
16 (8)	19	0,4	5	●	●	●	●	●	●	●
20 (9)	23	0,4	5	●	●	●	●	●	●	●
25 (10)	28	0,4	5	●	●	●	●	●	●	●
32 (11)	35	0,4	5	●	●	●	●	●	●	●

Ordering example:

2201.7G

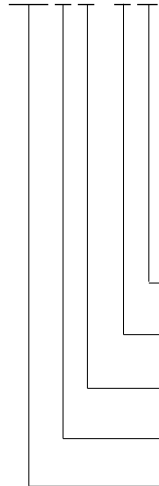

Length: l
100 mm
Diameter: d_1
13 mm
Type:
ISO
Version:
Blank
Punch:
without ejector pin (22)

Order Code character
= (G)
Order No
= (7)
Order No
= (1)
Order No
= (0)

FIBRO

2211.

**Precision Punches,
stepped, ISO 8020**



2211. Version: Round (1)

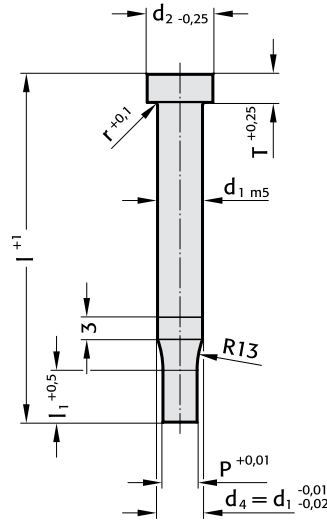

Material:

HSS
 Hardness: shaft 64±2 HRC
 head 52±5 HRC
 ASP 23 – ASP 2023
 upon request

Execution:

Punch head hot upset-forged, punch, shoulder and punch diameter fine ground.

Ordering example:

Synopsis see fold out page E63

2211.

d ₁ / (Order No)	d ₂	P	l ₁ / (Order No)		r	T	l / (Order Code character)				
							71 (D)	80 (E)	90 (F)	100 (G)	120 (J)
3 (1)	5	0,8- 2,9	8 (1)	10 (2)	0,25	3	●	●	●	●	●
4 (2)	6	1,0- 3,9	8 (1)	13 (3)	0,25	3	●	●	●	●	●
5 (3)	8	1,5- 4,9	13 (3)	19 (4)	0,3	5	●	●	●	●	●
6 (4)	9	1,6- 5,9	13 (3)	19 (4)	0,3	5	●	●	●	●	●
8 (5)	11	2,5- 7,9	19 (4)	25 (5)	0,3	5	●	●	●	●	●
10 (6)	13	4,0- 9,9	19 (4)	25 (5)	0,3	5	●	●	●	●	●
13 (7)	16	5,0-12,9	19 (4)	25 (5)	0,4	5	●	●	●	●	●
16 (8)	19	8,0-15,9	19 (4)	25 (5)	0,4	5	●	●	●	●	●
20 (9)	23	12,0-19,9	19 (4)	25 (5)	0,4	5	●	●	●	●	●
25 (10)	28	16,5-24,9	19 (4)	25 (5)	0,4	5	●	●	●	●	●
32 (11)	35	20,0-31,9	25 (5)	30 (6)	0,4	5	●	●	●	●	●

Ordering example:

2 2 1 1 . 7 G 4 . 0 7 0 0

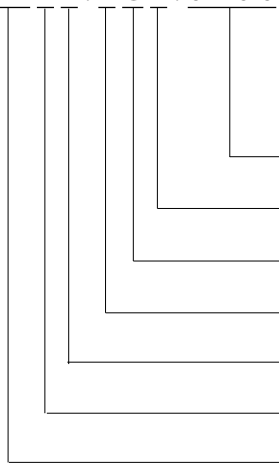

Version: Round
 P = ø7,0 mm
Punch cutting length: l₁
 19 mm
Length: l
 100 mm
Diameter: d₁
 13 mm
Type:
 ISO
Version:
 Round
Punch:
 without ejector pin (22)

= (0700)
Order No
 = (4)
Order Code character
 = (G)
Order No
 = (7)
Order No
 = (1)
Order No
 = (1)

**Precision Punches,
stepped, ISO 8020**

2221. 2231.
2241. 2251.

2221. Version: Square (2)

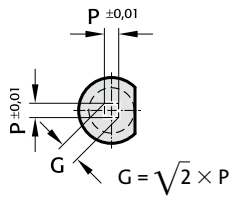

2231. Version: Rectangular (3)

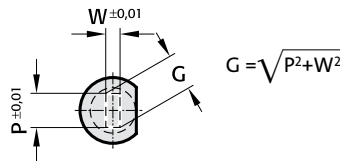

2241. Version: Slot (4)

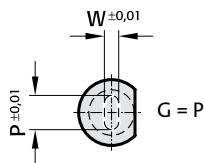

2251. Rectangle with radiused corners (5)

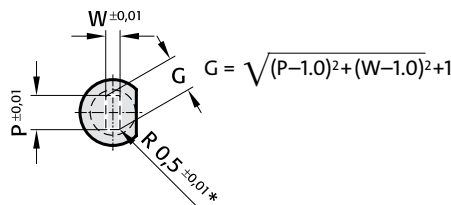

* For other radius options, see standardised special shapes, pages E 100 – E 101



2221./ 2231./ 2241. / 2251.

d ₁ /(Order No)	d ₂	W _{min.}	G _{max.}	l ₁ /(Order No)	r	T	l/(Order Code character)					
							(D)	(E)	(F)	(G)	(J)	
3 (1)	5	0,5	2,9	8 (1)	10 (2)	0,25	3	●	●	●	●	●
4 (2)	6	0,8	3,9	8 (1)	13 (3)	0,25	3	●	●	●	●	●
5 (3)	8	1,0	4,9	13 (3)	19 (4)	0,3	5	●	●	●	●	●
6 (4)	9	1,6	5,9	13 (3)	19 (4)	0,3	5	●	●	●	●	●
8 (5)	11	2,0	7,9	19 (4)	25 (5)	0,3	5	●	●	●	●	●
10 (6)	13	3,5	9,9	19 (4)	25 (5)	0,3	5	●	●	●	●	●
13 (7)	16	4,5	12,9	19 (4)	25 (5)	0,4	5	●	●	●	●	●
16 (8)	19	6,0	15,9	19 (4)	25 (5)	0,4	5	●	●	●	●	●
20 (9)	23	8,0	19,9	19 (4)	25 (5)	0,4	5	●	●	●	●	●
25 (10)	28	10,0	24,9	19 (4)	25 (5)	0,4	5	●	●	●	●	●
32 (11)	35	10,0	31,9	25 (4)	30 (6)	0,4	5	●	●	●	●	●

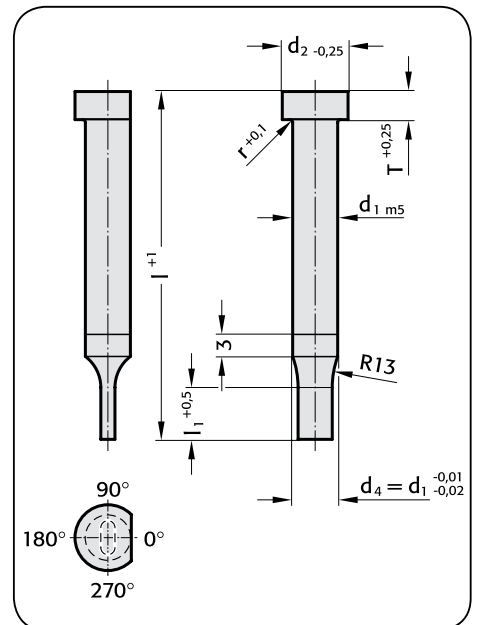

Ordering example:

2 2 4 1 . 1 0 E 5 . 2 0 2 0 . 1 2 2 0 A

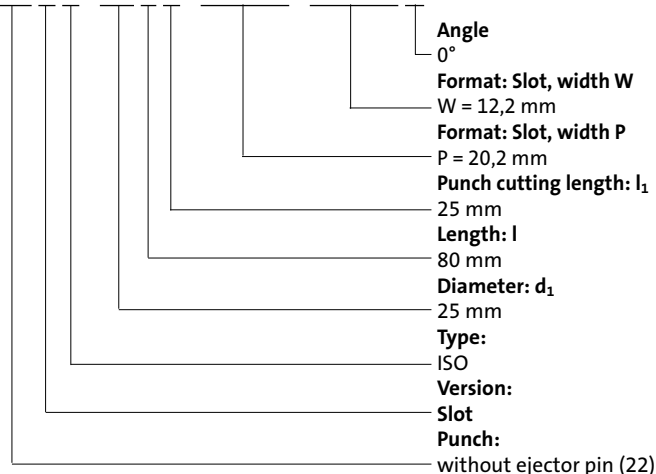

Order Code character = (A)
= (1220)
= (2020)
Order No = (5)
Order Code character = (E)
Order No = (10)
Order No = (1)
Order No = (4)

Material:

HSS
Hardness: shaft 64±2 HRC
head 52±5 HRC

Execution:

Punch head hot upset-forged, shaft, shoulder and punch shape fine ground.

The anti-rotation surface parallel to P = 0° as standard.

ASP 23 – ASP 2023 upon request

Ordering example:

Synopsis see fold out page E63

FIBRO

2701.

Precision Punches,
blank, with ejector pin,
ISO 8020



2701. Version: Blank (0)

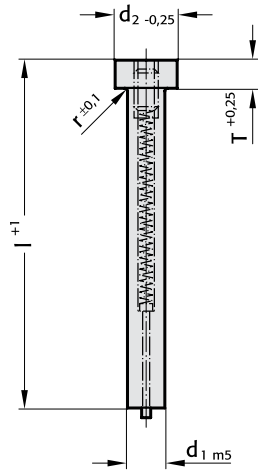

Material:

HSS
Hardness: shaft 64±2 HRC
head 52±5 HRC

Execution:

Punch head hot upset-forged, shaft and shoulder fine ground.

Ordering example:

Synopsis see fold out page E63

2701.

d ₁ / (Order No)	d ₂	r	T	l / (Order Code character)				
				71 (D)	80 (E)	90 (F)	100 (G)	120 (J)
5 (3)	8	0,3	5	●	●	●	●	●
6 (4)	9	0,3	5	●	●	●	●	●
8 (5)	11	0,3	5	●	●	●	●	●
10 (6)	13	0,3	5	●	●	●	●	●
13 (7)	16	0,4	5	●	●	●	●	●
16 (8)	19	0,4	5	●	●	●	●	●
20 (9)	23	0,4	5	●	●	●	●	●
25 (10)	28	0,4	5	●	●	●	●	●
32 (11)	35	0,4	5	●	●	●	●	●

Ordering example:

2 7 0 1 . 1 1 G

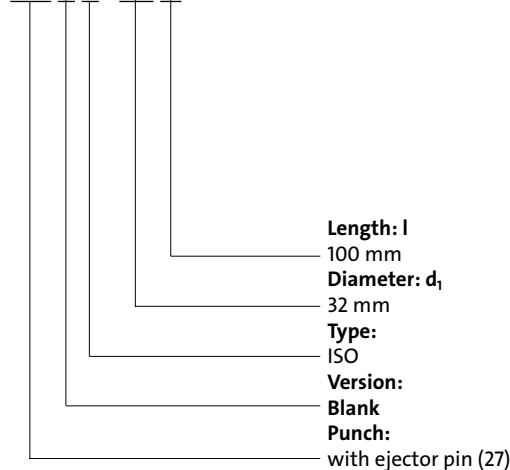

Order Code character
= (G)
Order No
= (11)
Order No
= (1)
Order No
= (0)

Precision Punches,
stepped, with ejector pin,
ISO 8020

FIBRO

2711.



2711. Version: Round (1)

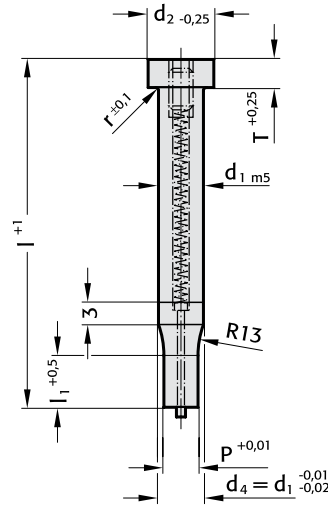

Material:

HSS
Hardness: shaft 64±2 HRC
head 52±5 HRC

Execution:

Punch head hot upset-forged, shaft, shoulder and punch diameter fine ground.

Ordering example:

Synopsis see fold out page E63

2711.

d ₁ / (Order No)	d ₂	P	l ₁ / (Order No)		r	T	l / (Order Code character)				
							71 (D)	80 (E)	90 (F)	100 (G)	120 (J)
5 (3)	8	1,6- 4,9	13 (3)	19 (4)	0,3	5	●	●	●	●	●
6 (4)	9	2,5- 5,9	13 (3)	19 (4)	0,3	5	●	●	●	●	●
8 (5)	11	2,5- 7,9	19 (4)	25 (5)	0,3	5	●	●	●	●	●
10 (6)	13	4,0- 9,9	19 (4)	25 (5)	0,3	5	●	●	●	●	●
13 (7)	16	5,0-12,9	19 (4)	25 (5)	0,4	5	●	●	●	●	●
16 (8)	19	8,0-15,9	19 (4)	25 (5)	0,4	5	●	●	●	●	●
20 (9)	23	12,0-19,9	19 (4)	25 (5)	0,4	5	●	●	●	●	●
25 (10)	28	16,5-24,9	19 (4)	25 (5)	0,4	5	●	●	●	●	●
32 (11)	35	20,0-31,9	25 (5)	30 (6)	0,4	5	●	●	●	●	●

Ordering example:

2711.7G4.0700

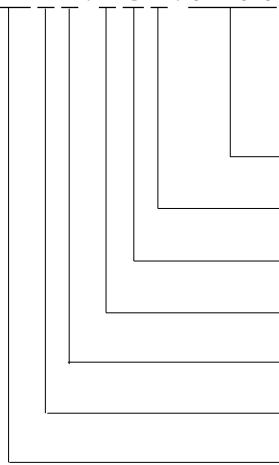

Format: Round
P = ø7,0 mm
Punch cutting length: l₁
19 mm
Length: l
100 mm
Diameter: d₁
13 mm
Type:
ISO
Version:
Round
Punch:
with ejector pin (27)

= (0700)
Order No
= (4)
Order Code character
= (G)
Order No
= (7)
Order No
= (1)
Order No
= (1)

FIBRO

2721. 2731.
2741. 2751.

Precision Punches, stepped, with ejector pin, ISO 8020

2721. Version: Square (2)

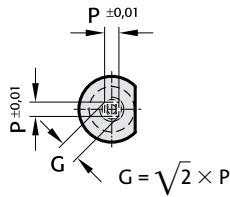

2731. Version: Rectangular (3)

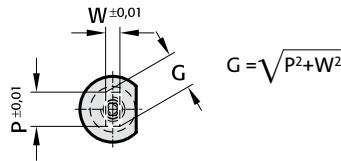

2741. Version: Slot (4)

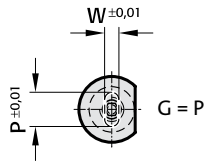

2751. Rectangle with radiused corners (5)

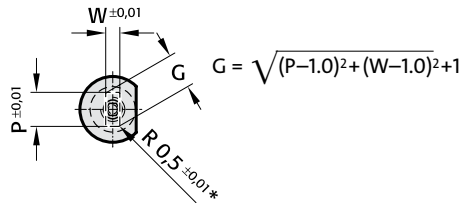

* For other radius options, see standardised special shapes, pages E 100 – E 101

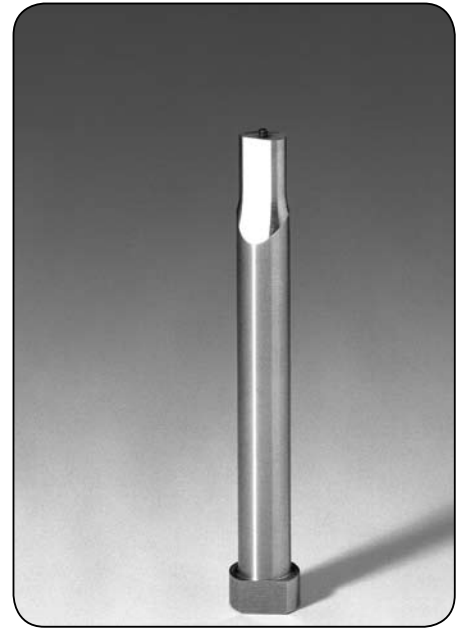

2721./ 2731./ 2741./ 2751.

d ₁ / (Order No)	d ₂	W _{min.}	G _{max.}	l ₁ / (Order No)	r	T	l / (Order Code character)					
							71 (D)	80 (E)	90 (F)	100 (G)	120 (J)	
5 (3)	8	1,6	4,9	13 (3)	19 (4)	0,3	5	●	●	●	●	●
6 (4)	9	2,5	5,9	13 (3)	19 (4)	0,3	5	●	●	●	●	●
8 (5)	11	2,5	7,9	19 (4)	25 (5)	0,3	5	●	●	●	●	●
10 (6)	13	4,0	9,9	19 (4)	25 (5)	0,3	5	●	●	●	●	●
13 (7)	16	5,0	12,9	19 (4)	25 (5)	0,4	5	●	●	●	●	●
16 (8)	19	8,0	15,9	19 (4)	25 (5)	0,4	5	●	●	●	●	●
20 (9)	23	12,0	19,9	19 (4)	25 (5)	0,4	5	●	●	●	●	●
25 (10)	28	16,5	24,9	19 (4)	25 (5)	0,4	5	●	●	●	●	●
32 (11)	35	20,0	31,9	25 (5)	30 (6)	0,4	5	●	●	●	●	●

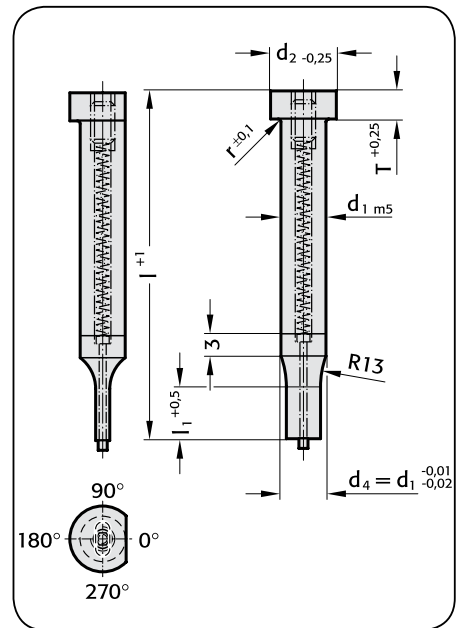

Ordering example:

2741.10D4.2040.1440B

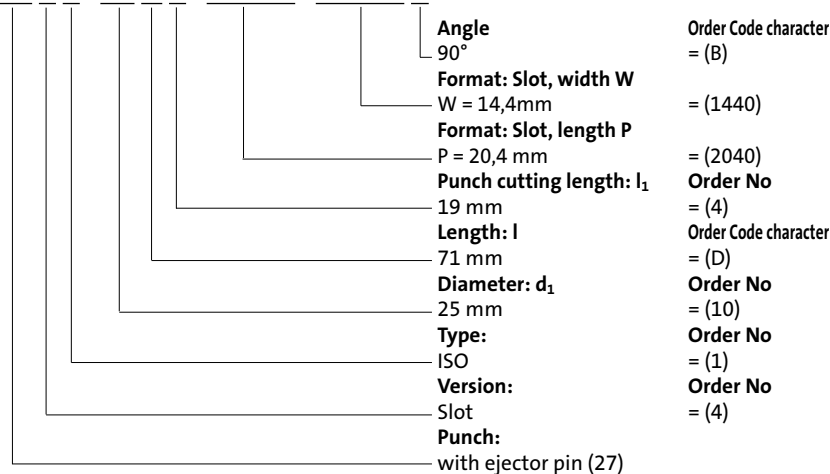

Material:

HSS
Hardness: shaft 64±2 HRC
head 52±5 HRC

Execution:

Punch head hot upset-forged, shoulder, shaft and punch shape fine ground.

The anti-rotation surface parallel to P = 0° as standard.

Ordering example:

Synopsis see fold out page E63

Pilot Pins with tapered tip,
ISO 8020

2261.



2261. Version: Pilot pin with tapered tip (6)

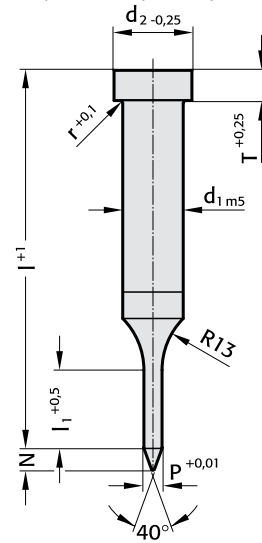

2261.

d ₁ / (Order No)	d ₂	T	P	l ₁ / (Order No)	N	l / (Order Code character)										
						63 (C)	71 (D)	80 (E)	90 (F)	100 (G)	110 (H)	125 (K)	140 (L)			
5 (3)	8	5	1,0- 4,9	13 (3) -- --	4	●	●									
6 (4)	9	5	1,6- 5,9	13 (3) -- --	5	●	●	●								
8 (5)	11	5	2,5- 7,9	13 (3) -- --	6	●	●	●	●							
10 (6)	13	5	4,0- 9,9	13 (3) 19 (4) --	8	●	●	●	●	●	●					
13 (7)	16	5	5,0-12,9	13 (3) 19 (4) --	10	●	●	●	●	●	●	●				
16 (8)	19	5	8,0-15,9	13 (3) 19 (4) 25 (5)	15		●	●	●	●	●	●	●			
20 (9)	23	5	12,0-19,9	13 (3) 19 (4) 25 (5)	20		●	●	●	●	●	●	●	●		
25 (10)	28	5	16,5-24,9	13 (3) 19 (4) 25 (5)	25		●	●	●	●	●	●	●	●	●	
32 (11)	35	5	20,0-31,9	-- 19 (4) 25 (5)	30			●	●	●	●	●	●	●	●	

Ordering example:

2 2 6 1 . 1 0 D 3 . 1 7 5 0

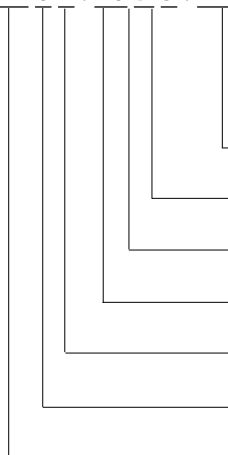

Format: Round
 P = ø 17,5 mm = (1750)
Punch cutting length l₁: Order No
 25 mm = (3)
Length: l Order Code character
 71 mm = (D)
Diameter: d₁ Order No
 32 mm = (10)
Type: Order No
 ISO = (1)
Version: Order No
 Pilot pin with tapered tip = (6)
Punch:
 without ejector pin (22)

Material:

HSS
 Hardness: shaft 64±2 HRC
 head 52±5 HRC

Execution:

Head hot upset-forged, shoulder, shaft and pilot fine ground.

Ordering example:

Synopsis see fold out page E63

2271. Version: Pilot pin parabolic tip (7)

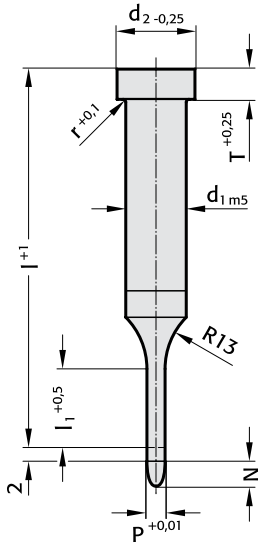

2271.

d ₁ / (Order No)	d ₂	T	P	l ₁ / (Order No)	l / (Order Code character)							
					50 (A)	56 (B)	63 (C)	71 (D)	80 (E)	90 (F)	100 (G)	
5 (3)	8	5	1,0- 4,9	10 (2) 13 (3) --	●	●	●	●				
6 (4)	9	5	1,6- 5,9	10 (2) 13 (3) --	●	●	●	●	●			
8 (5)	11	5	2,5- 7,9	10 (2) 13 (3) --	●	●	●	●	●			
10 (6)	13	5	4,0- 9,9	10 (2) 13 (3) 19 (4)	●	●	●	●	●	●		●
13 (7)	16	5	5,0-12,9	10 (2) 13 (3) 19 (4)	●	●	●	●	●	●		●
16 (8)	19	5	8,0-15,9	-- 13 (3) 19 (4)	●	●	●	●	●	●		●
20 (9)	23	5	12,0-19,9	-- 13 (3) 19 (4)		●	●	●	●	●		●
25 (10)	28	5	16,5-24,9	-- 13 (3) 19 (4)		●	●	●	●	●		●
32 (11)	35	5	20,0-31,9	-- -- 19 (4)				●	●	●		●

Ordering example:

2 2 7 1 . 1 0 B 3 . 2 3 0 0

- Format: Round**
- P = ø 23 mm = (2300)
- Punch cutting length l₁:** Order No = (3)
25 mm
- Length: l** Order Code character = (B)
56 mm
- Diameter: d₁** Order No = (10)
32 mm
- Type:** Order No = (1)
ISO
- Version:** Order No = (7)
Pilot pin parabolic tip
- Punch:**
without ejector pin (22)

Material:

HSS
Hardness: shaft 64±2 HRC
head 52±5 HRC

Execution:

Head hot upset-forged, shoulder, shaft and pilot fine ground.

„l“ length of pilot pin is without tip

Note: The 2 mm length provides full guidance before the blanking punch contacts the sheet metal.

	P	N
	≤ 10 mm	8 mm
10,1 mm	- 15 mm	12 mm
	> 15 mm	15 mm

Ordering example:

Synopsis see fold out page E63

Pilot Units
to Daimler Standard

2276.



2276.

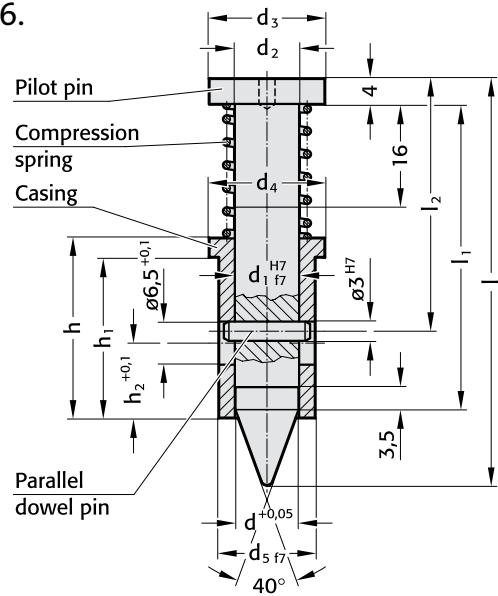

Description:

The pilot unit provides exact positioning of sheet metal parts. There are 2 sizes.

The pilot unit 10 can be used for a hole diameter of 5 ~ 10 mm and is available as a finished item, 9.8 mm diameter. Smaller diameters have to be ground by the tool making department.

The pilot unit 16 is used for diameter 10 - 16 mm and is available as a blank, 15.8 mm diameter.

Material:

The pilot unit consists of:
Pilot pin, Casing, Compression spring, Parallel dowel pin.

2276.

Order No	d	d ₁	d ₂	d ₃	d ₄	d ₅	h	h ₁	h ₂	l ₁	l ₂	l	Spring force in daN	
													preloaded	compressed
2276.1.	9.8	10	10	18	18	15	28	25	12	47.5	39.3	63.2	4.9	6.2
2.	15.8	16	16	24	30	26	28	25	12	54.5	46.3	72.5	4.8	5.6

Ordering example:

2 2 7 6 . 1 . A . 0 9 8 0

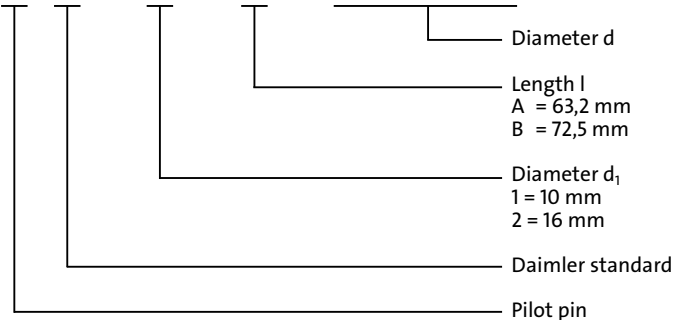

Precision Matrixes

A large, empty rectangular box with rounded corners, occupying most of the page. It is intended for drawing or writing.

Ordering example Precision Matrixes

NB: See table for standard dimensions
Special dimensions to order

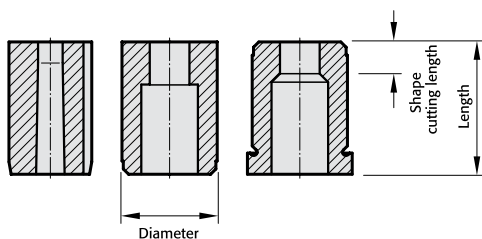

2 6 4 6 . 10 F 6 . 1 3 5 0 . 0 6 5 0 A 2

Matrixes:
26 matrixes

Format: Slot length
P = 13,5 mm

Format:
Slot width
W = 6,5 mm

Version:	Order No
⊙ blank (pilot hole bore)	= 0
⊙ round	= 1
⊖ square	= 2
⊖ rectangular	= 3
⊖ slot	= 4
⊖ rectangle with radiused corners	= 5
⊖ special shapes	= 9

Shape cutting length: l	Order No
2	= 1
3	= 2
4	= 3
5	= 4
6	= 5
8	= 6
10	= 7
12	= 8
special	= X

Diameter: d ₂	Order No
5	= 1
6	= 2
8	= 3
10	= 4
13	= 5
16	= 6
20	= 7
22	= 8
25	= 9
32	= 10
38	= 11
40	= 12
45	= 13
50	= 14
56	= 15
63	= 16
71	= 17
76	= 18
86	= 19
90	= 20
100	= 21

Length: l ₁	Order Code character
13	= A
16	= B
20	= C
22	= D
25	= E
28	= F
30	= G
32	= H
35	= J
40	= K
special	= X

Angle:	Order Code character
0°	= A
90°	= B
180°	= C
270°	= D
special	= X

Anti-rotation element:	Order No
pin Ø 3	= 1
pin Ø 4	= 2
pin Ø 6	= 3
polished surface (continuous)	= 4
polished surface, top, 14 mm	= 5
polished surface, bottom, 14 mm	= 6
special	= X

Type:	Order No
automotive standard	= 5
without shoulder ISO 8977	= 6
with shoulder ISO 8977	= 7

Ordering Code (Example):

2 6 4 6 . 10 F 6 . 1 3 5 0 . 0 6 5 0 A 2

- Anti-rotation element = Pin Ø4 (2)
- Angle = 0° (A)
- Format: Slot, width W = 6,5 mm (0650)
- Format: Slot, length P = 13,5 mm (1350)
- Shape cutting length: l = 8 mm (6)
- Length: l₁ = 28 mm (F)
- Diameter: d₂ = 32 mm (10)
- Type = without shoulder ISO 8977 (6)
- Version: Slot (4)
- Matrixes:
Matrixes (26)

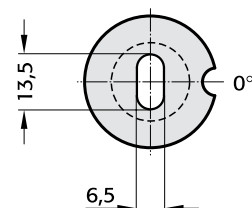
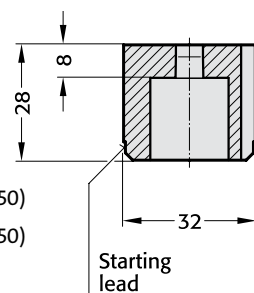

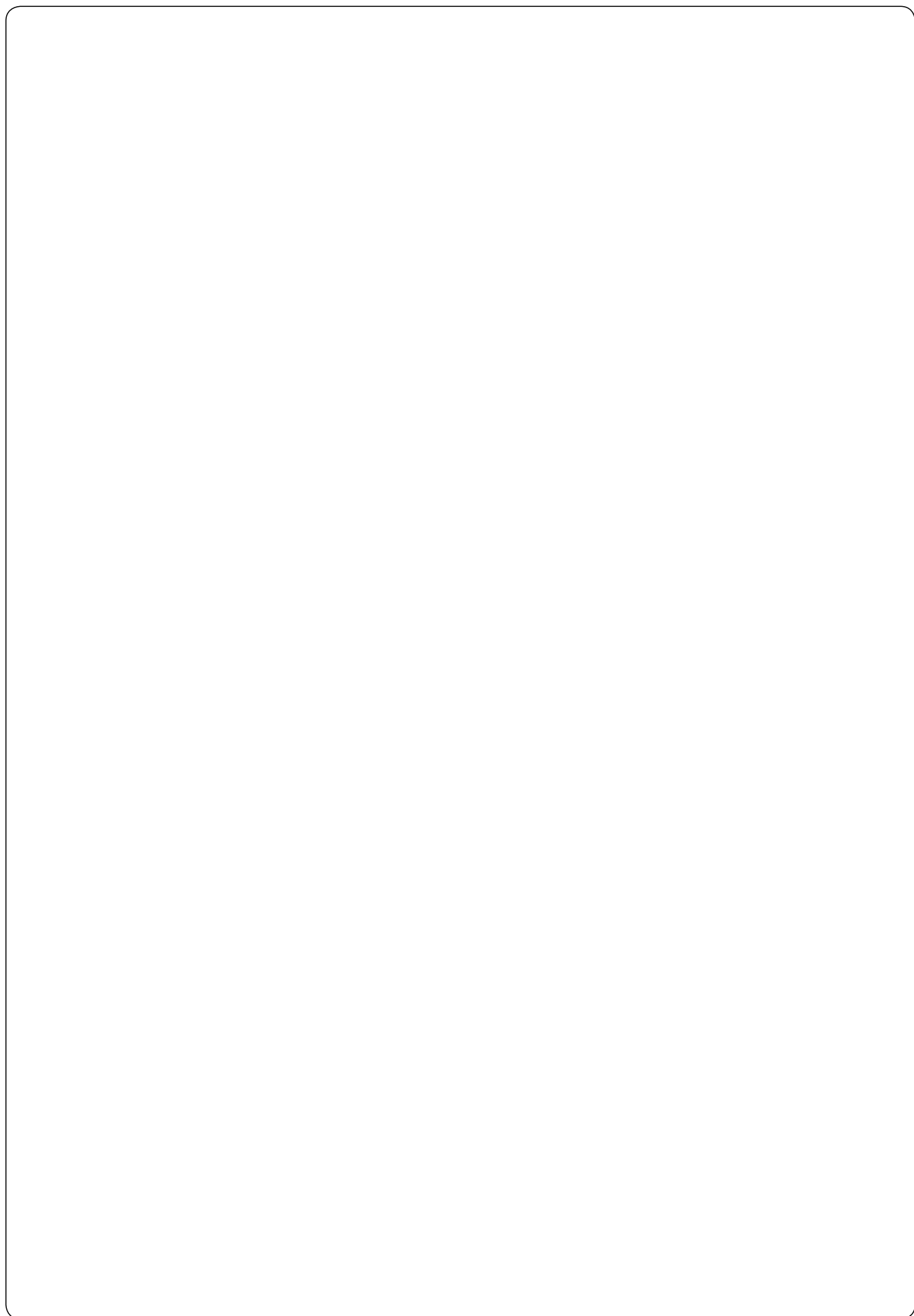

2606.

Material:

HSS
hardened: 62 ± 2 HRC

Execution:

Diameter d_2 , starting lead and face surfaces ground.
Diameter P is a bored pilot hole for wire EDM.

Ordering example:

Synopsis see fold out page E75.

2606.

Version: Blank (Pilot hole bore) (0)

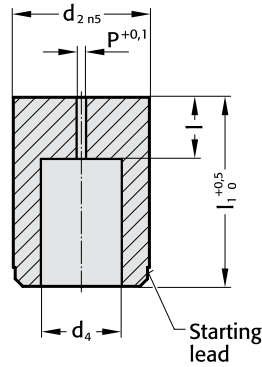

2606.

d_2 / (Order No)	d_4	P	l / (Order No)	l_1 / (Order Code character)										
				16 (B)	20 (C)	22 (D)	25 (E)	28 (F)	30 (G)	32 (H)	35 (J)	40 (K)		
5 (1)	2,8	0,8	2 (1)	●	●	●	●	●	●	●	●	●		
6 (2)	3,5	1,0	3 (2)	●	●	●	●	●	●	●	●	●		
8 (3)	4,0	1,0	4 (3)	●	●	●	●	●	●	●	●	●		
10 (4)	5,8	1,0	4 (3) 8 (6)	●	●	●	●	●	●	●	●	●		
13 (5)	8,0	1,2	5 (4) 8 (6)		●	●	●	●	●	●	●	●		
16 (6)	9,5	1,2	5 (4) 8 (6)		●	●	●	●	●	●	●	●		
20 (7)	12,0	1,5	8 (6) 12 (8)		●	●	●	●	●	●	●	●		
22 (8)	15,0	1,5	8 (6) 12 (8)		●	●	●	●	●	●	●	●		
25 (9)	17,3	1,5	8 (6) 12 (8)		●	●	●	●	●	●	●	●		
32 (10)	20,7	1,5	8 (6) 12 (8)		●	●	●	●	●	●	●	●		
40 (12)	27,7	1,5	8 (6) 12 (8)				●	●	●	●	●	●		
50 (14)	37,0	1,5	8 (6) 12 (8)				●	●	●	●	●	●	●	

Other lengths on request

Ordering example:

2606.10F8

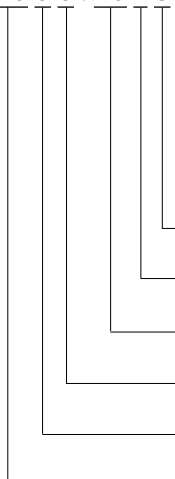

Shape cutting length: l
12 mm
Length: l_1
28 mm
Diameter: d_2
32 mm
Type:
without sholder ISO 8977
Version:
Blank (pilot hole bore)
Matrixes:
26 Matrixes

Order No
= (8)
Order Code character
= (F)
Order No
= (10)
Order No
= (6)
Order No
= (0)

Precision Matrixes
without shoulder, cylindrical
ISO 8977

FIBRO

2616.



2616.

Version: Round (1)

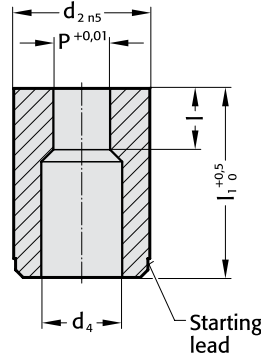

Material:

HSS
hardened: 62 ± 2 HRC

Execution:

Diameter d_2 , starting lead and face surfaces ground.

Ordering example:

Synopsis see fold out page E75.

2616.

d_2 / (Order No)	d_4	P	l / (Order No)	l_1 / (Order Code character)										
				16 (B)	20 (C)	22 (D)	25 (E)	28 (F)	30 (G)	32 (H)	35 (J)	40 (K)		
5 (1)	2,8	1,0- 2,4	2 (1)	●	●	●	●	●	●	●	●	●		
6 (2)	3,5	1,6- 3,0	3 (2)	●	●	●	●	●	●	●	●	●		
8 (3)	4,0	2,0- 3,5	4 (3)	●	●	●	●	●	●	●	●	●		
10 (4)	5,8	2,5- 5,0	4 (3) 8 (6)	●	●	●	●	●	●	●	●	●		
13 (5)	8,0	4,0- 7,0	5 (4) 8 (6)		●	●	●	●	●	●	●	●		
16 (6)	9,5	6,0- 9,0	5 (4) 8 (6)		●	●	●	●	●	●	●	●		
20 (7)	12,0	8,0-11,0	8 (6) 12 (8)		●	●	●	●	●	●	●	●		
22 (8)	15,0	9,0-14,0	8 (6) 12 (8)		●	●	●	●	●	●	●	●		
25 (9)	17,3	10,7-16,0	8 (6) 12 (8)		●	●	●	●	●	●	●	●		
32 (10)	20,7	15,0-20,0	8 (6) 12 (8)		●	●	●	●	●	●	●	●		
40 (12)	27,7	19,0-27,0	8 (6) 12 (8)				●	●	●	●	●	●		
50 (14)	37,0	26,0-36,0	8 (6) 12 (8)					●	●	●	●	●	●	●

Other lengths on request

Ordering example: without anti-rotation element

2 6 1 6 . 1 0 F 8 . 1 5 1 0

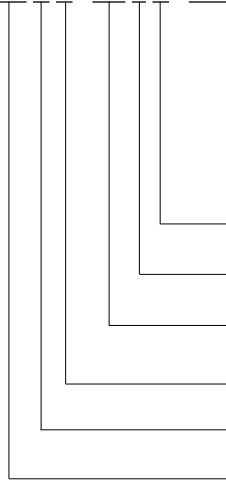

Format: Round
P = \varnothing 15,1 mm = (1510)
Shape cutting length: l = (8)
12 mm = (8)
Length: l_1 = (F)
28 mm = (F)
Diameter: d_2 = (10)
32 mm = (10)
Type: = (6)
without sholder ISO 8977 = (6)
Version: = (1)
Round = (1)
Matrixes:
26 Matrixes

Ordering example: with anti-rotation element from $d_2 \geq 10$ mm

2 6 1 6 . 1 0 F 8 . 1 5 1 0 A 4

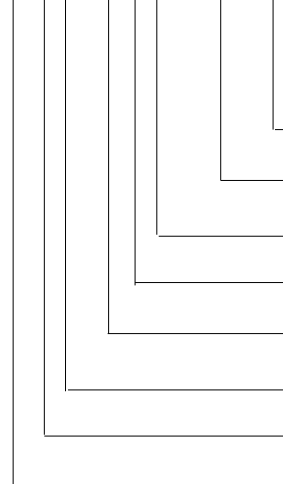

Anti-rotation element: = (4)
Polished surface (continuous)
Angle: = (A)
0° = (A)
Format: Round
P = \varnothing 15,1 mm = (1510)
FormschneidLength: l = (8)
12 mm = (8)
Length: l_1 = (F)
28 mm = (F)
Diameter: d_2 = (10)
32 mm = (10)
Type: = (6)
without sholder ISO 8977 = (6)
Version: = (1)
Round = (1)
Matrixes:
26 Matrixes

anti-rotation element 1 (1)

Pin $\varnothing 3$	
d_2	F
10	5
13	6,5
16	8
20	10
22	11
25	12,5
32	16
40	20
50	25

anti-rotation element 2 (2)

Pin $\varnothing 4$	
d_2	F
10	6
13	7,2
16	8
20	10
22	11
25	12,5
32	16
40	20
50	25

anti-rotation element 3 (3)

Pin $\varnothing 6$	
d_2	F
10	7
13	8,2
16	9
20	11
22	12
25	13,5
32	16
40	20
50	25

anti-rotation element 4 (4)

d_2	F
10	4
13	5,5
16	7
20	8,5
22	9,5
25	11
32	14
40	18
50	23

anti-rotation element 5 (5)

d_2	F
10	4
13	5,5
16	7
20	8,5
22	9,5
25	11
32	14
40	18
50	23

anti-rotation element 6 (6)

d_2	F
10	4
13	5,5
16	7
20	8,5
22	9,5
25	11
32	14
40	18
50	23

Ordering example:
Synopsis see fold out page E75.

**Precision Matrixes
without shoulder, cylindrical
ISO 8977**

FIBRO

2626. 2636.
2646. 2656.



2626. Version: Square (2)

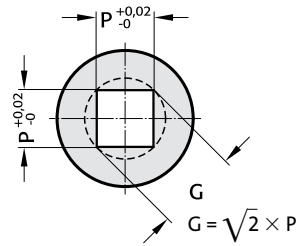

2636. Version: Rectangular (3)

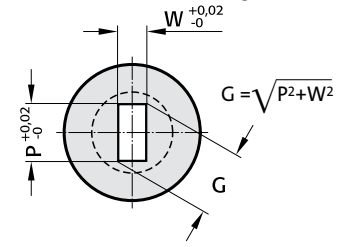

2646. Version: Slot (4)

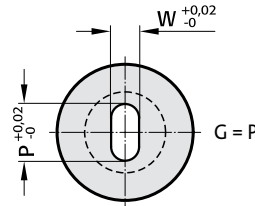

2656. Version: Rectangle with radiused corners (5)

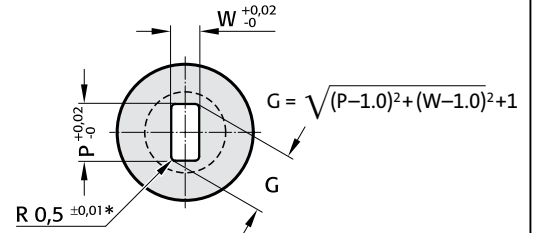

* For other radius options, see standardised special shapes, pages E100 – E101.

Material:

HSS
hardened: 62 ± 2 HRC

Execution:

Diameter d_2 , starting lead and face surfaces ground.

Ordering example:

Synopsis see fold out page E75.

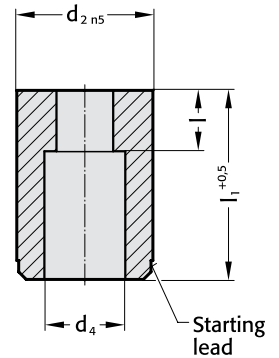
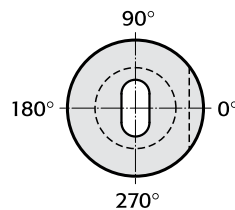
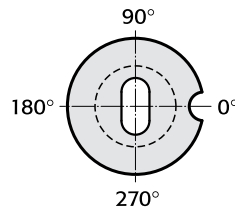

2626./ 2636./ 2646./ 2456.

d_2 / (Order No)	d_4	$W_{min.}$	$G_{max.}$	l / (Order No)		l_1 / (Order Code character)											
						16 (B)	20 (C)	22 (D)	25 (E)	28 (F)	30 (G)	32 (H)	35 (J)	40 (K)			
10 (4)	5,8	1,2	5,0	4 (3)	8 (6)	●	●	●	●	●	●	●	●	●	●	●	●
13 (5)	8,0	2,0	7,0	5 (4)	8 (6)		●	●	●	●	●	●	●	●	●	●	●
16 (6)	9,5	2,4	9,0	5 (4)	8 (6)		●	●	●	●	●	●	●	●	●	●	●
20 (7)	12,0	3,2	11,0	8 (6)	12 (8)		●	●	●	●	●	●	●	●	●	●	●
22 (8)	15,0	4,0	14,0	8 (6)	12 (8)		●	●	●	●	●	●	●	●	●	●	●
25 (9)	17,3	4,8	16,0	8 (6)	12 (8)		●	●	●	●	●	●	●	●	●	●	●
32 (10)	20,7	5,5	20,0	8 (6)	12 (8)			●	●	●	●	●	●	●	●	●	●
40 (12)	27,7	6,4	27,0	8 (6)	12 (8)				●	●	●	●	●	●	●	●	●
50 (14)	37,0	9,0	36,0	8 (6)	12 (8)				●	●	●	●	●	●	●	●	●

Other lengths on request

anti-rotation element 1 (1)

Pin $\varnothing 3$	
d_2	F
10	5
13	6,5
16	8
20	10
22	11
25	12,5
32	16
40	20
50	25

Starting lead

$d_{2\ ns}$

F

90°

180°

0°

270°

anti-rotation element 2 (2)

Pin $\varnothing 4$	
d_2	F
10	6
13	7,2
16	8
20	10
22	11
25	12,5
32	16
40	20
50	25

Starting lead

$d_{2\ ns}$

F

90°

180°

0°

270°

anti-rotation element 3 (3)

Pin $\varnothing 6$	
d_2	F
10	7
13	8,2
16	9
20	11
22	12
25	13,5
32	16
40	20
50	25

Starting lead

$d_{2\ ns}$

F

90°

180°

0°

270°

anti-rotation element 4 (4)

d_2	F
10	4
13	5,5
16	7
20	8,5
22	9,5
25	11
32	14
40	18
50	23

Starting lead

$d_{2\ ns}$

F

90°

180°

0°

270°

anti-rotation element 5 (5)

d_2	F
10	4
13	5,5
16	7
20	8,5
22	9,5
25	11
32	14
40	18
50	23

Starting lead

$d_{2\ ns}$

F

90°

180°

0°

270°

anti-rotation element 6 (6)

d_2	F
10	4
13	5,5
16	7
20	8,5
22	9,5
25	11
32	14
40	18
50	23

Starting lead

$d_{2\ ns}$

F

90°

180°

0°

270°

Ordering example:

2636.10F8.1350.0650A4

Anti-rotation element:

Polished surface
(continuous)

Angle:
0°

Format: Rectangular, width W
W = 6,5 mm

Format: Rectangular, length P
P = 13,5 mm

Shape cutting length: l
12 mm

Length: l₁
28 mm

Diameter: d₂
32 mm

Type:
without sholder ISO 8977

Version:
Rectangular

Matrixes:
26 Matrixes

Order No

= (4)

Order Code character

= (A)

= (0650)

= (1350)

Order No

= (8)

Order Code character

= (F)

Order No

= (10)

Order No

= (6)

Order No

= (3)

Ordering example:

Synopsis see fold out page E75.

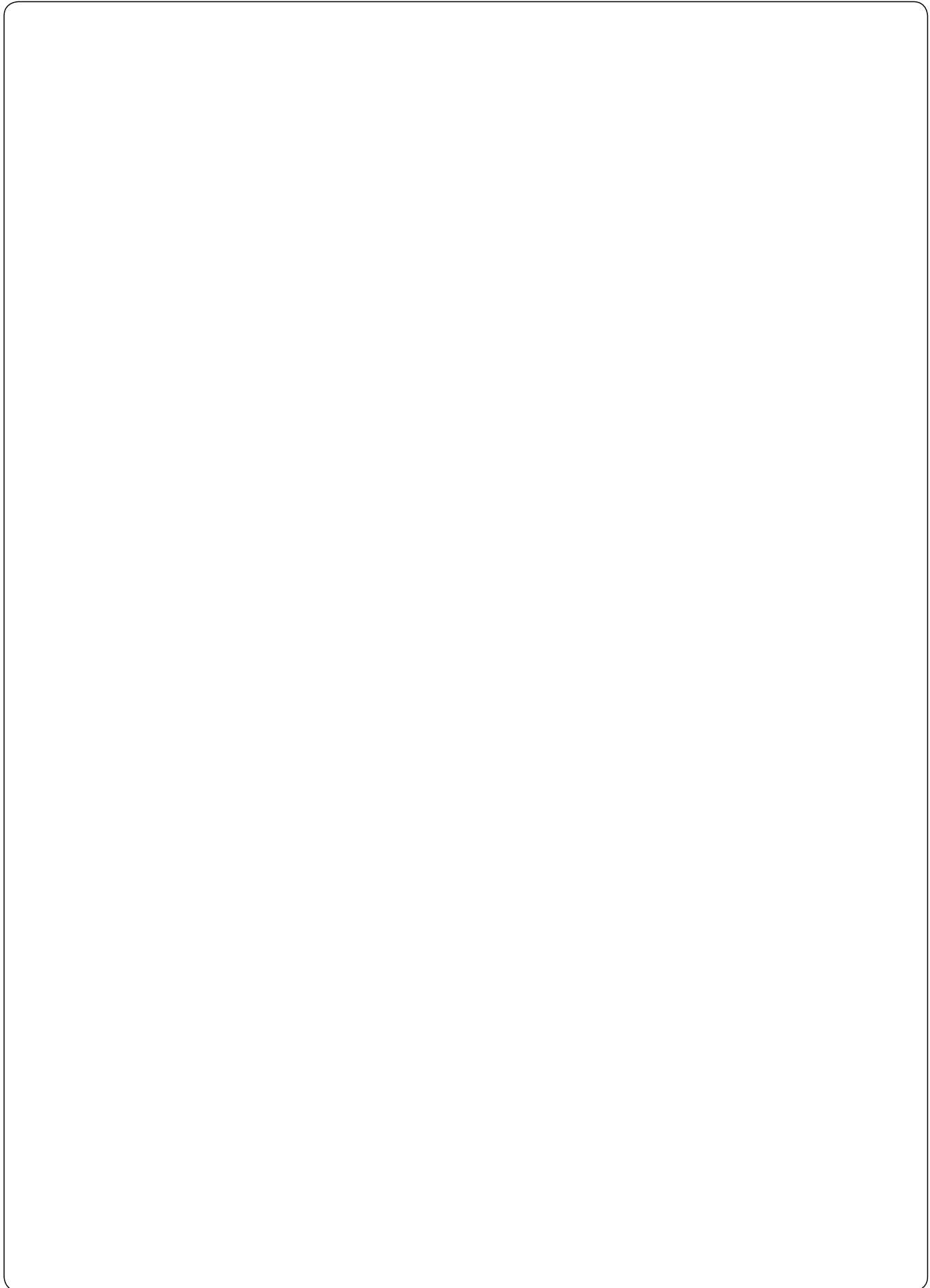

FIBRO

2607.

Precision Matrixes with shoulder, cylindrical, ISO 8977

Material:

HSS
hardened: 62 ± 2 HRC

Execution:

Diameter d_2 , and end faces ground.

Diameter P is a bored pilot hole for wire EDM.

Ordering example:

Synopsis see fold out page E75.

2607.

Version: Blank (pilot hole bore) (0)

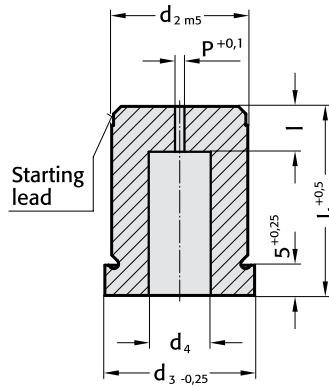

2607.

d_2 /(Order No)	d_3	d_4	P	l/(Order No)	l_1 /(Order Code character)							
					16 (B)	20 (C)	22 (D)	25 (E)	28 (F)	30 (G)	32 (H)	35 (J)
5 (1)	8	2,8	0,8	2 (1)	●	●	●	●	●	●	●	●
6 (2)	9	3,5	1,0	3 (2)	●	●	●	●	●	●	●	●
8 (3)	11	4,0	1,0	4 (3)	●	●	●	●	●	●	●	●
10 (4)	13	5,8	1,0	4 (3) 8 (6)	●	●	●	●	●	●	●	●
13 (5)	16	8,0	1,2	5 (4) 8 (6)		●	●	●	●	●	●	●
16 (6)	19	9,5	1,2	5 (4) 8 (6)		●	●	●	●	●	●	●
20 (7)	23	12,0	1,5	8 (6) 12 (8)		●	●	●	●	●	●	●
22 (8)	25	15,0	1,5	8 (6) 12 (8)		●	●	●	●	●	●	●
25 (9)	28	17,3	1,5	8 (6) 12 (8)		●	●	●	●	●	●	●
32 (10)	35	20,7	1,5	8 (6) 12 (8)		●	●	●	●	●	●	●
40 (12)	43	27,7	1,5	8 (6) 12 (8)		●	●	●	●	●	●	●
50 (14)	53	37,0	1,5	8 (6) 12 (8)		●	●	●	●	●	●	●

Other lengths on request

Ordering example:

2607.10F8

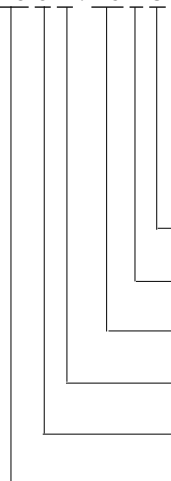

Shape cutting length: l
12 mm
Length: l_1
28 mm
Diameter: d_2
32 mm
Type:
with sholder ISO 8977
Version:
Blank (pilot hole bore)
Matrixes:
26 Matrixes

Order No
= (8)
Order Code character
= (F)
Order No
= (10)
Order No
= (7)
Order No
= (0)

Precision Matrixes with shoulder, cylindrical, ISO 8977

2617.



2617. Version: Round (1)

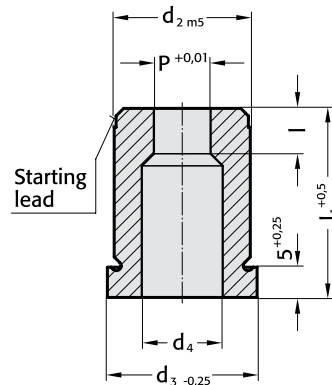

Material:

HSS
hardened: 62 ± 2 HRC

Execution:

Diameter d_2 , and end faces ground.

Ordering example:

Synopsis see fold out page E75.

2617.

d_2 / (Order No)	d_3	d_4	P	l / (Order No)	l_1 / (Order Code character)							
					16 (B)	20 (C)	22 (D)	25 (E)	28 (F)	30 (G)	32 (H)	35 (J)
5 (1)	8	2,8	1,0- 2,4	2 (1)	●	●	●	●	●	●	●	●
6 (2)	9	3,5	1,6- 3,0	3 (2)	●	●	●	●	●	●	●	●
8 (3)	11	4,0	2,0- 3,5	4 (3)	●	●	●	●	●	●	●	●
10 (4)	13	5,8	2,5- 5,0	4 (3) 8 (6)	●	●	●	●	●	●	●	●
13 (5)	16	8,0	4,0- 7,0	5 (4) 8 (6)		●	●	●	●	●	●	●
16 (6)	19	9,5	6,0- 9,0	5 (4) 8 (6)		●	●	●	●	●	●	●
20 (7)	23	12,0	8,0-11,0	8 (6) 12 (8)		●	●	●	●	●	●	●
22 (8)	25	15,0	9,0-14,0	8 (6) 12 (8)		●	●	●	●	●	●	●
25 (9)	28	17,3	10,7-16,0	8 (6) 12 (8)		●	●	●	●	●	●	●
32 (10)	35	20,7	15,0-20,0	8 (6) 12 (8)		●	●	●	●	●	●	●
40 (12)	43	27,7	19,0-27,0	8 (6) 12 (8)		●	●	●	●	●	●	●
50 (14)	53	37,0	26,0-36,0	8 (6) 12 (8)		●	●	●	●	●	●	●

Other lengths on request

Ordering example: without anti-rotation element

2617.10F8.1510

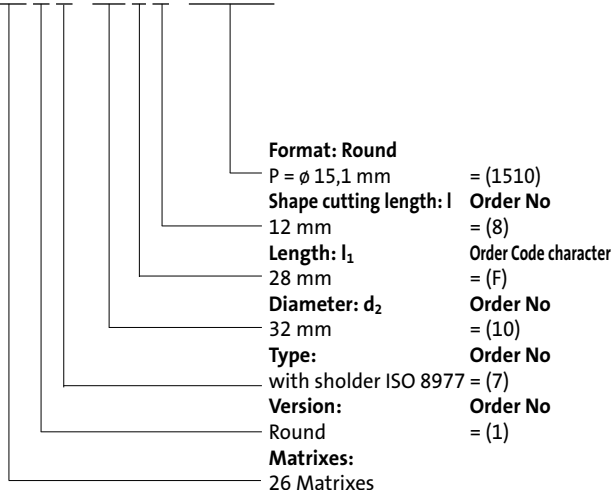

Ordering example: with anti-rotation element from $d_2 \geq 8$ mm

2617.10F8.1510A4

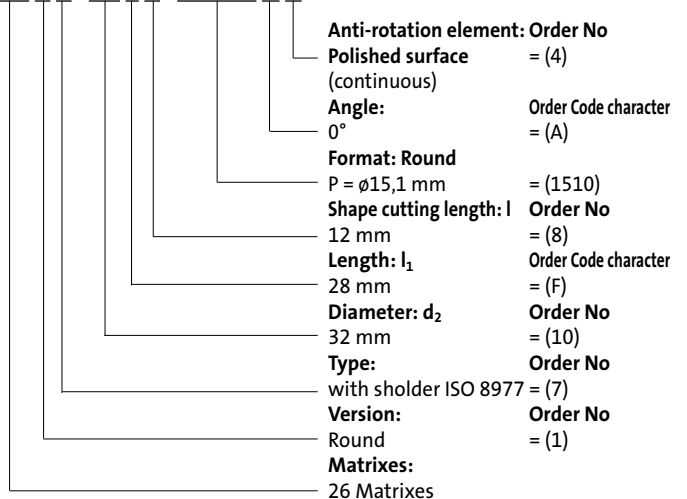

Anti-rotation element 1 (1)

Starting lead

Pin $\varnothing 3$	
d_2	F
8	5,5
10	6,5
13	8
16	9,5
20	11,5
22	12,5
25	14
32	17,5
40	21,5
50	26,5

Anti-rotation element 2 (2)

Starting lead

Pin $\varnothing 4$	
d_2	F
8	6
10	7
13	8,5
16	10
20	12
22	13
25	14,5
32	18
40	22
50	27

Anti-rotation element 3 (3)

Starting lead

Pin $\varnothing 6$	
d_2	F
8	7
10	8
13	9,5
16	11
20	13
22	14
25	15,5
32	19
40	23
50	28

Anti-rotation element 4 (4)

Starting lead

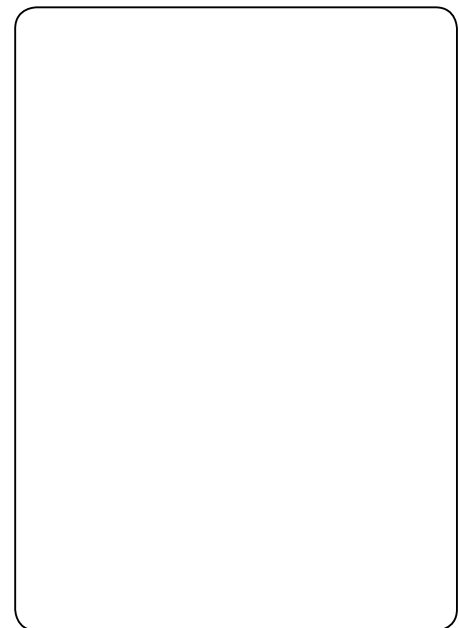
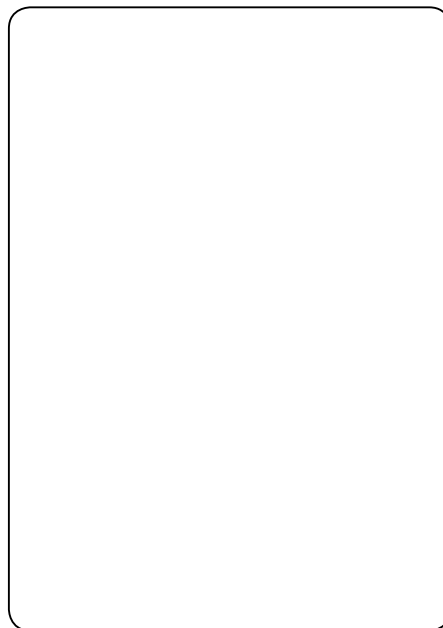

Ordering example:
Synopsis see fold out page E75.

Precision Matrixes with shoulder,
cylindrical ISO 8977

2627. 2637.
2647. 2657.



2627. Version: Square (2)

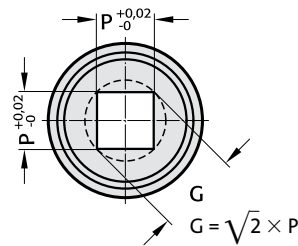

2637. Version: Rectangular (3)

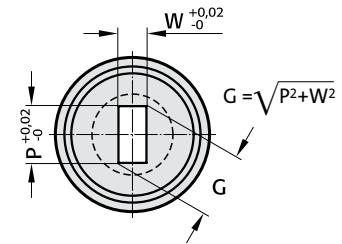

2647. Version: Slot (4)

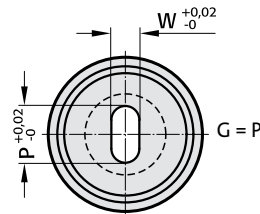

2657. Version: Rectangle with radiused corners (5)

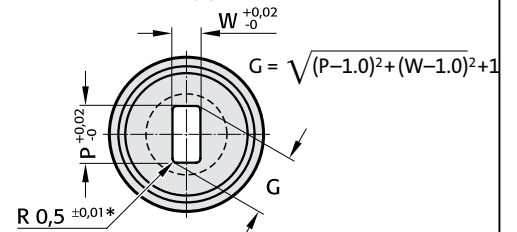

* For other radius options, see standardised special shapes, pages E100 – E101.

Material:

HSS
hardened: 62 ± 2 HRC

Execution:

Diameter d_2 , and end faces ground.

Ordering example:

Synopsis see fold out page E75.

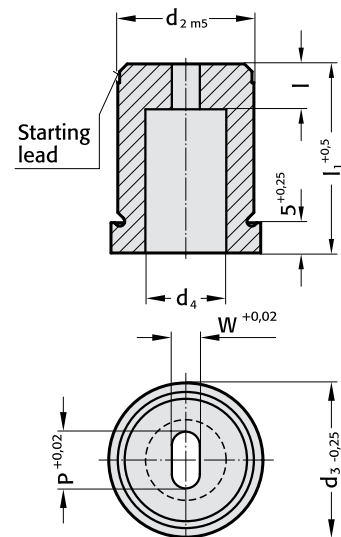
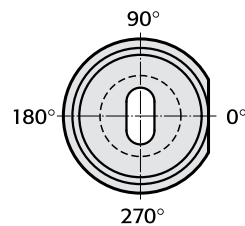
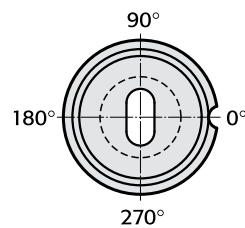

2627./ 2637./ 2647./ 2457.

d_2 /(Order No)	d_3	d_4	$W_{min.}$	$G_{max.}$	I/(Order No)	l_1 /(Order Code character)									
						16 (B)	20 (C)	22 (D)	25 (E)	28 (F)	30 (G)	32 (H)	35 (J)		
8 (3)	11	4,0	1,2	3,5	4 (3)	●	●	●	●	●	●	●	●	●	●
10 (4)	13	5,8	1,2	5,0	4 (3) 8 (6)	●	●	●	●	●	●	●	●	●	●
13 (5)	16	8,0	2,0	7,0	5 (4) 8 (6)		●	●	●	●	●	●	●	●	●
16 (6)	19	9,5	2,4	9,0	5 (4) 8 (6)		●	●	●	●	●	●	●	●	●
20 (7)	23	12,0	3,2	11,0	8 (6) 12 (8)		●	●	●	●	●	●	●	●	●
22 (8)	25	15,0	4,0	14,0	8 (6) 12 (8)		●	●	●	●	●	●	●	●	●
25 (9)	28	17,3	4,8	16,0	8 (6) 12 (8)		●	●	●	●	●	●	●	●	●
32 (10)	35	20,7	5,5	20,0	8 (6) 12 (8)		●	●	●	●	●	●	●	●	●
40 (12)	43	27,7	6,4	27,0	8 (6) 12 (8)		●	●	●	●	●	●	●	●	●
50 (14)	53	37,0	6,4	36,0	8 (6) 12 (8)		●	●	●	●	●	●	●	●	●

Other lengths on request

Anti-rotation element 1 (1)

Starting lead

Pin $\varnothing 3$	
d_2	F
8	5,5
10	6,5
13	8
16	9,5
20	11,5
22	12,5
25	14
32	17,5
40	21,5
50	26,5

Anti-rotation element 2 (2)

Starting lead

Pin $\varnothing 4$	
d_2	F
8	6
10	7
13	8,5
16	10
20	12
22	13
25	14,5
32	18
40	22
50	27

Anti-rotation element 3 (3)

Starting lead

Pin $\varnothing 6$	
d_2	F
8	7
10	8
13	9,5
16	11
20	13
22	14
25	15,5
32	19
40	23
50	28

Anti-rotation element 4 (4)

Starting lead

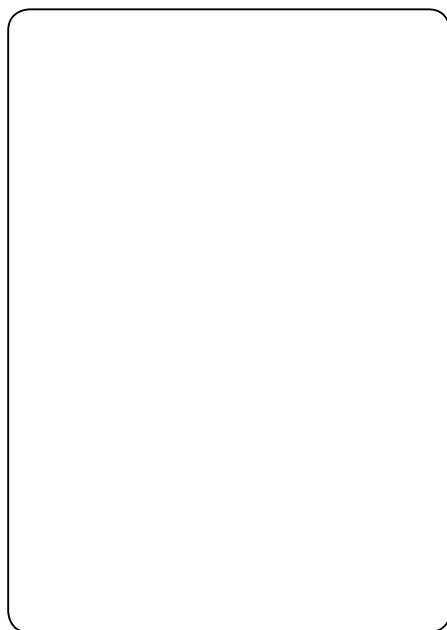
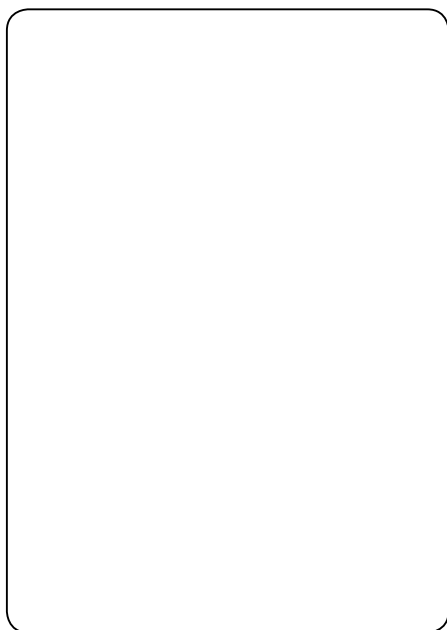

Ordering example:

2 6 3 7 . 10 F 8 . 13 5 0 . 06 5 0 A 4

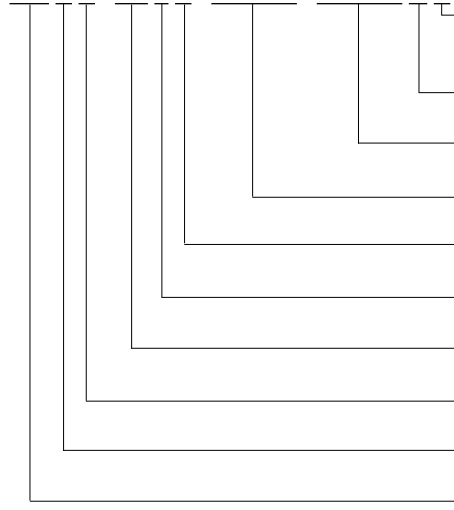

- Anti-rotation element:** Order No = (4)
- Polished surface (continuous)
- Angle:** Order Code character = (A)
- 0°
- Format: Rectangular, width W** = (0650)
- W = 6,5 mm
- Format: Rectangular, length P** = (1350)
- P = 13,5 mm
- Shape cutting length: l** Order No = (8)
- 12 mm
- Length: l₁** Order Code character = (F)
- 28 mm
- Diameter: d₂** Order No = (10)
- 32 mm
- Type:** Order No = (7)
- with sholder ISO 8977
- Version:** Order No = (3)
- Rectangular
- Matrixes:**
- 26 Matrixes

Ordering example:
Synopsis see fold out page E75.

Matrixes without shoulder,
automotive standard

2605.



2605.

Version: Blank (pilot hole bore) (0)

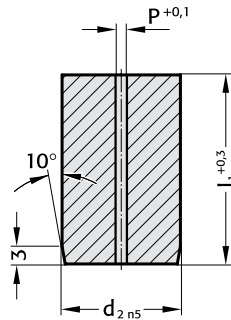

Material:

HSS
hardened: 62±2 HRC

Execution:

Diameter d_2 , and end faces ground.
Diameter P is a bored pilot hole for wire EDM

Ordering example:

Synopsis see fold out page E75.

2605.

d_2 / (Order No)	P	l_1 / (Order Code character)										
		13 (A)	16 (B)	20 (C)	22 (D)	25 (E)	28 (F)	30 (G)	32 (H)	35 (J)	40 (K)	
10 (4)	0,8	●	●	●	●	●	●	●	●	●	●	●
13 (5)	0,8	●	●	●	●	●	●	●	●	●	●	●
16 (6)	1,5			●	●	●	●	●	●	●	●	●
20 (7)	2,4			●	●	●	●	●	●	●	●	●
22 (8)	3,0			●	●	●	●	●	●	●	●	●
25 (9)	3,0			●	●	●	●	●	●	●	●	●
32 (10)	3,0			●	●	●	●	●	●	●	●	●
38 (11)	3,0			●	●	●	●	●	●	●	●	●
40 (12)	3,0				●	●	●	●	●	●	●	●
45 (13)	3,0				●	●	●	●	●	●	●	●
50 (14)	3,0				●	●	●	●	●	●	●	●
56 (15)	3,0				●	●	●	●	●	●	●	●
63 (16)	3,0				●	●	●	●	●	●	●	●
71 (17)	3,0				●	●	●	●	●	●	●	●
76 (18)	3,0				●	●	●	●	●	●	●	●
86 (19)	3,0				●	●	●	●	●	●	●	●
90 (20)	3,0				●	●	●	●	●	●	●	●
100 (21)	3,0				●	●	●	●	●	●	●	●

Other lengths on request

Ordering example:

2605.10F

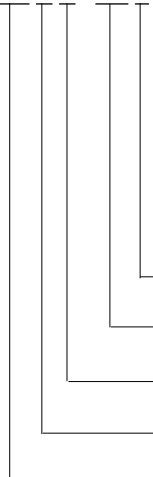

Length: l_1
28 mm
Diameter: d_2
32 mm
Type:
without sholder Automotive Standaard
Version:
Blank (pilot hole bore)
Matrixes:
26 Matrixes

Order Code character
= (F)
Order No
= (10)
Order No
= (5)
Order No
= (0)

2615.

Matrixes without shoulder, automotive standard

Material:

HSS
hardened: 62±2 HRC

Execution:

Diameter d_2 , and end faces ground.

Ordering example:

Synopsis see fold out page E75.

2615.

Version: Round (1)

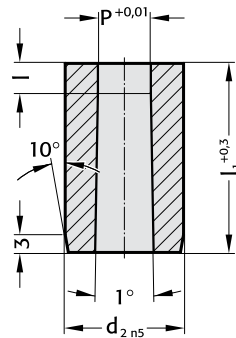

2615.

d_2 / (Order No)	P	l / (Order No)	l_1 / (Order Code character)									
			13 (A)	16 (B)	20 (C)	22 (D)	25 (E)	28 (F)	30 (G)	32 (H)	35 (J)	40 (K)
10 (4)	1,6- 6,8	3 (2) 4 (3) 5 (4)	●	●	●	●	●	●	●	●	●	●
13 (5)	3,0- 8,8	3 (2) 5 (4) 8 (6)	●	●	●	●	●	●	●	●	●	●
16 (6)	7,4-10,8	3 (2) 5 (4) 8 (6)			●	●	●	●	●	●	●	●
20 (7)	9,5-13,6	3 (2) 5 (4) 10 (7)			●	●	●	●	●	●	●	●
22 (8)	10,5-15,0	3 (2) 6 (5) 10 (7)			●	●	●	●	●	●	●	●
25 (9)	12,0-17,0	3 (2) 6 (5) 10 (7)			●	●	●	●	●	●	●	●
32 (10)	16,0-22,0	3 (2) 6 (5) 12 (8)			●	●	●	●	●	●	●	●
38 (11)	18,0-27,0	3 (2) 8 (6) 12 (8)			●	●	●	●	●	●	●	●
40 (12)	18,0-27,0	3 (2) 8 (6) 12 (8)				●	●	●	●	●	●	●
45 (13)	18,0-35,0	3 (2) 8 (6) 12 (8)				●	●	●	●	●	●	●
50 (14)	18,0-40,0	3 (2) 8 (6) 12 (8)				●	●	●	●	●	●	●
56 (15)	18,0-45,0	3 (2) 8 (6) 12 (8)				●	●	●	●	●	●	●
63 (16)	18,0-50,0	3 (2) 8 (6) 12 (8)				●	●	●	●	●	●	●
71 (17)	18,0-56,0	3 (2) 8 (6) 12 (8)				●	●	●	●	●	●	●
76 (18)	25,0-60,0	3 (2) 8 (6) 12 (8)					●	●	●	●	●	●
86 (19)	25,0-66,0	3 (2) 8 (6) 12 (8)					●	●	●	●	●	●
90 (20)	32,0-70,0	3 (2) 8 (6) 12 (8)					●	●	●	●	●	●
100 (21)	32,0-78,0	3 (2) 8 (6) 12 (8)					●	●	●	●	●	●

Other lengths on request

Ordering example: without anti-rotation element

2 6 1 5 . 10 F 8 . 2 1 9 0

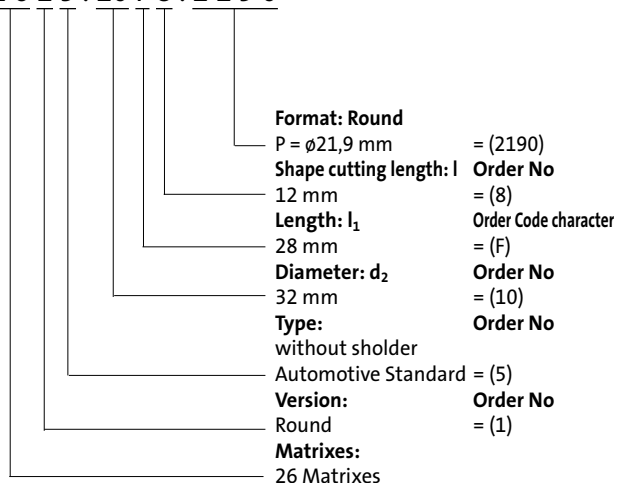

Ordering example: with anti-rotation element

2 6 1 5 . 10 F 8 . 2 1 9 0 A 3

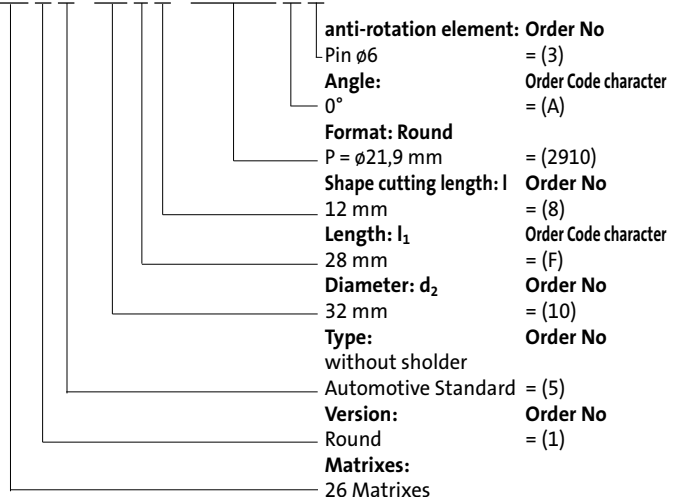

Matrixes without shoulder, automotive standard

2625. 2635.
2645. 2655.



2625. Version: Square (2)

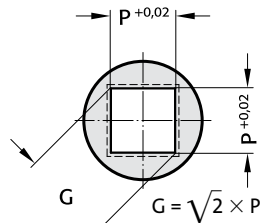

2635. Version: Rectangular (3)

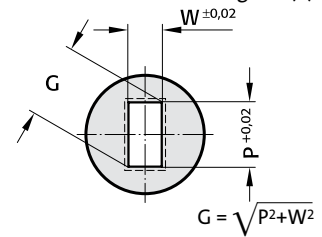

2645. Version: Slot (4)

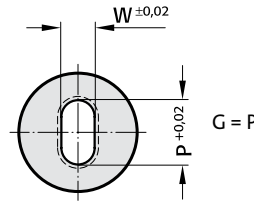

2655. Version: Rectangle with radiused corners (5)

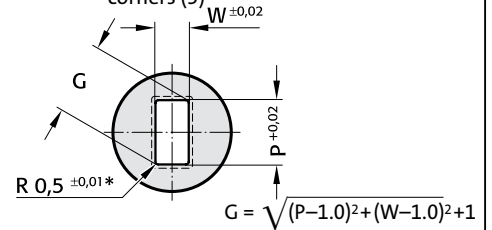

* For other radius options, see standardised special shapes, pages E100 – E101.

2625./ 2635./ 2645./ 2655.

d ₂ /(Order No)	W _{min}	G _{max}	l/(Order No)	l ₁ /(Order Code character)											
				13 (A)	16 (B)	20 (C)	22 (D)	25 (E)	28 (F)	30 (G)	32 (H)	35 (J)	40 (K)		
10 (4)	1,3	6,8	3 (2) 4 (3) 5 (4)	●	●	●	●	●	●	●	●	●	●	●	●
13 (5)	1,9	8,8	3 (2) 5 (4) 8 (6)	●	●	●	●	●	●	●	●	●	●	●	●
16 (6)	1,9	10,8	3 (2) 5 (4) 8 (6)			●	●	●	●	●	●	●	●	●	●
20 (7)	1,9	13,6	3 (2) 5 (4) 10 (7)			●	●	●	●	●	●	●	●	●	●
22 (8)	1,9	15,0	3 (2) 6 (5) 10 (7)			●	●	●	●	●	●	●	●	●	●
25 (9)	1,9	17,0	3 (2) 6 (5) 10 (7)			●	●	●	●	●	●	●	●	●	●
32 (10)	1,9	22,0	3 (2) 6 (5) 12 (8)			●	●	●	●	●	●	●	●	●	●
38 (11)	1,9	27,0	3 (2) 8 (6) 12 (8)				●	●	●	●	●	●	●	●	●
40 (12)	1,9	27,0	3 (2) 8 (6) 12 (8)				●	●	●	●	●	●	●	●	●
45 (13)	2,4	35,0	3 (2) 8 (6) 12 (8)				●	●	●	●	●	●	●	●	●
50 (14)	4,0	40,0	3 (2) 8 (6) 12 (8)				●	●	●	●	●	●	●	●	●
56 (15)	4,0	45,0	3 (2) 8 (6) 12 (8)				●	●	●	●	●	●	●	●	●
63 (16)	4,0	50,0	3 (2) 8 (6) 12 (8)				●	●	●	●	●	●	●	●	●
71 (17)	4,0	56,0	3 (2) 8 (6) 12 (8)				●	●	●	●	●	●	●	●	●
76 (18)	5,6	60,0	3 (2) 8 (6) 12 (8)				●	●	●	●	●	●	●	●	●
86 (19)	5,6	66,0	3 (2) 8 (6) 12 (8)				●	●	●	●	●	●	●	●	●
90 (20)	5,6	70,0	3 (2) 8 (6) 12 (8)				●	●	●	●	●	●	●	●	●
100 (21)	5,6	78,0	3 (2) 8 (6) 12 (8)				●	●	●	●	●	●	●	●	●

Other lengths on request

Material: HSS hardened 62±2

Execution: Diameter d₂ and end faces ground.

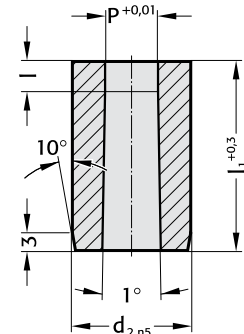

Ordering example:

Synopsis see fold out page E75.

Ordering example: without anti-rotation element

2635.10F8.1350.0650A3

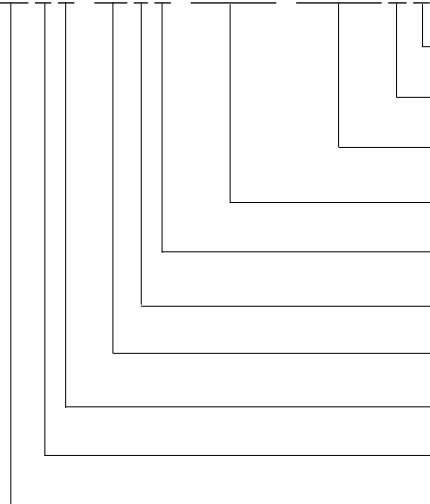

- Anti-rotation element:** Order No = (3)
Pin ø6
- Angle:** Order Code character = (A)
0°
- Format: Rectangular, width W**
W = 6,5 mm = (0650)
- Format: Rectangular, length P**
P = 13,5 mm = (1350)
- Shape cutting length: l** Order No = (8)
12 mm
- Length: l₁** Order Code character = (F)
28 mm
- Diameter: d₂** Order No = (10)
32 mm
- Type:** Order No = (5)
without sholder Automotive Standard
- Version:** Order No = (3)
Square
- Matrixes:**
26 Matrixes

Anti-rotation element 3 (3)

d ₂	F	Pin Ø6	
		d ₂	F
10	7		
13	8,2		
16	9		
20	11		
22	12		
25	13,5		
32	16		
38	19		
40	20		
45	22,5		
50	25		
56	28		
63	31,5		
71	35,5		
76	38		
85	42,5		
90	45		
100	50		

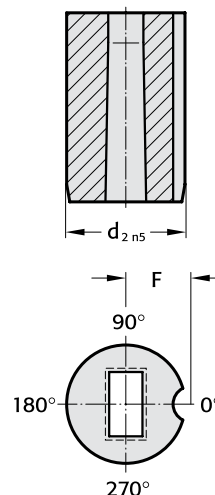

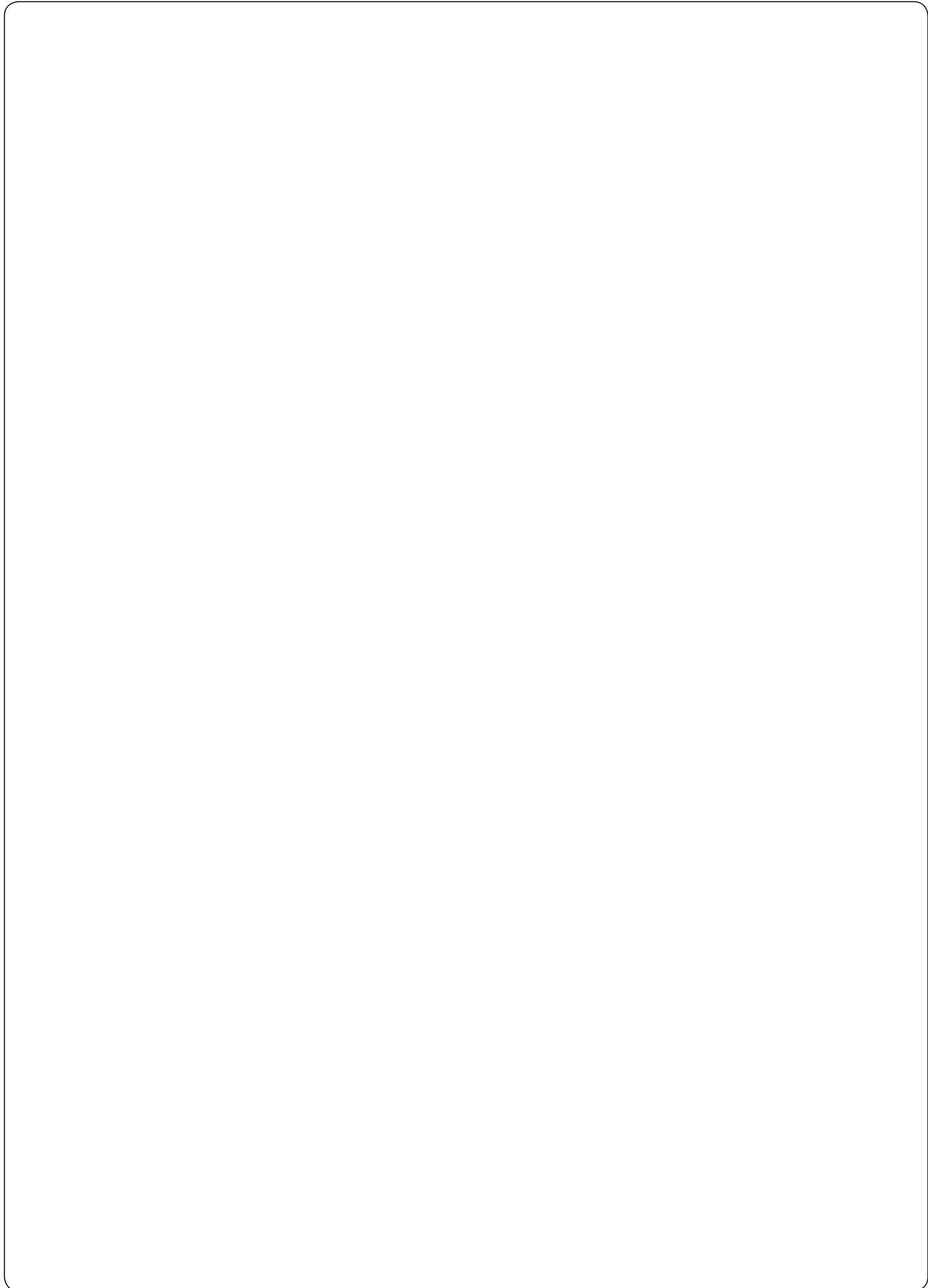

Precision Guide Bushes for Punches
DIN 9845, Shape C
ISO 8978

FIBRO

262.
2621.



Material:

262.
Case hardened steel
Order No. 262.1.
Hardness 740 ± 40 HV 10

2621.
WS, hardened
Order No 2621.1.
Hardness HRC 60 ± 2

Execution:

Diameters d_1 , d_2 and starting lead ground.

Description of FIBRO materials for die components:
pages E 10–E 11.

262. Shape C DIN 9845

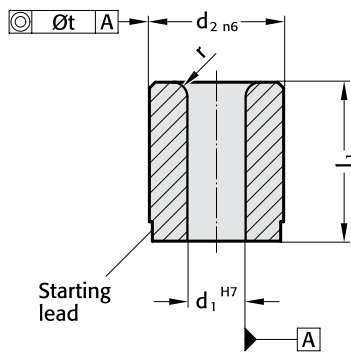

2621. ISO 8978

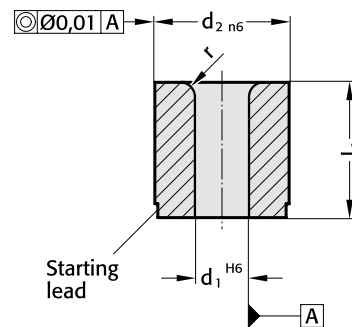

262.

d_1	Diameter steps	d_2	t	l_1	r
0,5– 1,0	0,1	5	0,01	9	1
1,1– 2,0		6		12	
2,1– 3,0		7			
3,1– 4,0		8			
4,1– 5,0		10		16	
5,1– 6,0		12	0,02		1,5
6,1– 8,0		15		20	
8,1–10,0		18			2
10,1–12,0		22		28	
12,1–15,0		26			
15,1–18,0	0,5	30		36	

Other diameters on request.

Ordering Code (example):

Guide Bush for punches DIN 9845 = 262.
Material case hardened steel = 1.
 $d_1 = \varnothing 2,4$ mm = 0240.
 $l_1 = 12$ mm = 012
Order No = 262.1.0240.012

2621.

d_1	Diameter steps	d_2	l_1	r
1,0– 2,4	0,1	5	8	1
1,6– 3,0		6	12,5	1
2,0– 3,5		8	12,5	1,5
3,0– 5,0		10	16	2
4,0– 7,2		13	16	2
6,0– 8,8		16	20	2
7,5–11,3		20	20	2,5
11,0–16,6		25	25	2,5
15,0–20,0	0,5	32	25	4
18,0–27,0		40	32	4
26,0–36,0		50	40	4

Ordering Code (example):

Guide Bush for punches ISO 8978 = 2621.
Material WS = 1.
 $d_1 = \varnothing 2,0$ mm = 0200.
 $d_2 = \varnothing 6$ mm = 0600
Order No = 2621.1.0200.0600

FIBRO

260.
261.

Precision Matrixes with and without collar DIN 9845 Shape A, Shape B

Material:

HSS
Order No: Shape A = 260.3.
 Shape B = 261.3.
Hardness: 62 ± 2 HRC

Description of FIBRO materials for die components: pages E 10–E 11.

260. Shape A

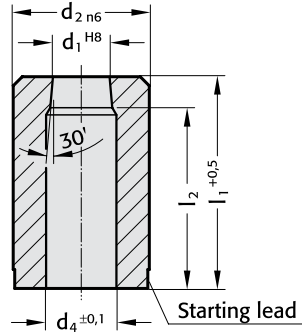

Execution:

Diameters d_1 , d_2 and face surfaces ground.

261. Shape B

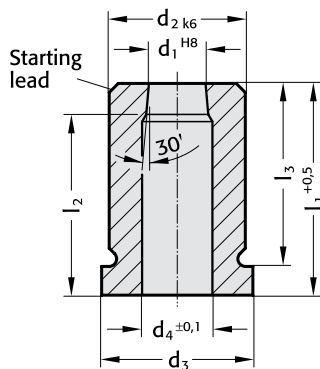

260.

Diameter d_1	steps	d_2	d_4	short		long	
				l_1	l_2	l_1	l_2
0,5– 1,0	0,1	5	$d_1^{+0,3}$	20	18	–	–
1,1– 2,0		6			17	28	25
2,1– 3,0		7	$d_1^{+0,5}$				
3,1– 4,0		8					
4,1 –5,0		10	$d_1^{+0,7}$		16		24
5,1– 6,0		12					
6,1– 8,0		15					
8,1–10,0		18	d_1^{+1}				
10,1–12,0		22			15		23
12,1–15,0		26					
15,1–18,0		30		–	–		

Other diameters on request.

261.

Diameter d_1	steps	d_2	d_3	d_4	short			long		
					l_1	l_2	l_3	l_1	l_2	l_3
0,5– 1,0	0,1	5	7	$d_1^{+0,3}$	20	18	16	–	–	–
1,1– 2,0		6	8			17		28	25	24
2,1– 3,0		7	9	$d_1^{+0,5}$						
3,1– 4,0		8	10							
4,1 –5,0		10	12	$d_1^{+0,7}$			16		24	
5,1– 6,0		12	14							
6,1– 8,0		15	17							
8,1–10,0		18	20	d_1^{+1}						
10,1–12,0		22	24			15			23	
12,1–15,0		26	28							
15,1–18,0		30	32		–	–	–			

Ordering Code (example):

Matrix = 261.
Material HSS = 3.
 $d_1 = \varnothing 2,20$ mm = 0220.
 $l_1 = 28$ mm = 028
Order No = 261.3.0220.028

Precision Matrixes with and without collar cylindrical

FIBRO

2602.

2612.



2602.

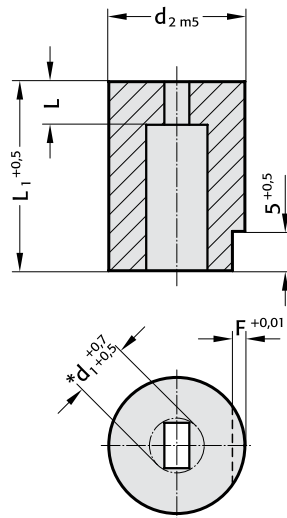

*d₁ = size over corners

Classified Shape

With starting holes for wire-EDM as per 2601. page E95

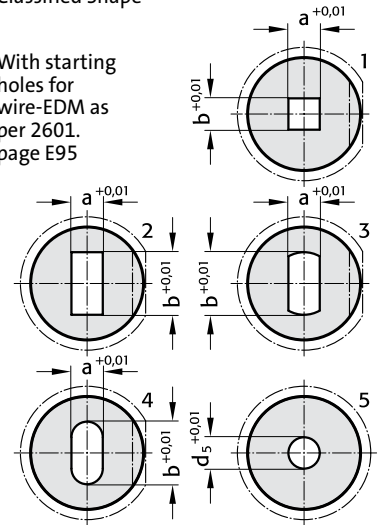

2612.

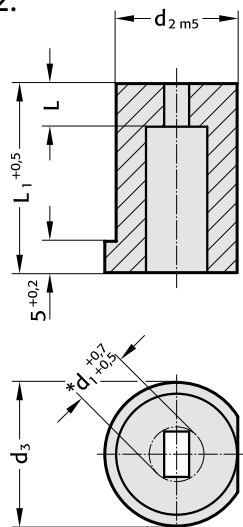

*d₁ = size over corners

Material:

HSS
Order No.: 2602. o. 2612.3.
Hardness: 64±2 HRC

Execution:

Diameters d₂ and face surfaces ground.
Key flats parallel with **A** unless otherwise specified.

2602.

Size over corners		L ₁								
d ₁ , d ₅	d ₂	L	F	16	19	22	25	28	32	
1,8 – 3,2	8	3	1,0	●	●	●	●	●	●	
2,0 – 5,0	10			●	●	●	●	●	●	
3,0 – 7,0	13		1,5	●	●	●	●	●	●	
5,0 – 8,0	16	5		●	●	●	●	●	●	
7,0 – 11,0	20			●	●	●	●	●	●	
11,0 – 16,0	25		2,5	●	●	●	●	●	●	
16,0 – 19,0	32	7		●	●	●	●	●	●	
19,0 – 28,0	40			●	●	●	●	●	●	

Ordering code (example):

Matrix = 2602.
Material HSS = 3.
d₂ = 16 mm = 016.
L₁ = 32 mm = 032.
Shape 2 = 2.
a = 3,96 mm = 0396.
b = 5,16 mm = 0516
Order No = 2602.3.016.032.2.0396.0516

2612.

Size over corners			L ₁								
d ₁ , d ₅	d ₂	d ₃	L	16	19	22	25	28	32		
1,8 – 3,2	8	11	3	●	●	●	●	●	●		
2,0 – 5,0	10	13		●	●	●	●	●	●		
3,0 – 7,0	13	16		●	●	●	●	●	●		
5,0 – 8,0	16	19	5	●	●	●	●	●	●		
7,0 – 11,0	20	23		●	●	●	●	●	●		
11,0 – 16,0	25	28		●	●	●	●	●	●		
16,0 – 19,0	32	35	7	●	●	●	●	●	●		
19,0 – 28,0	40	43		●	●	●	●	●	●		

Ordering code (example):

Matrix = 2612.
Material HSS = 3.
d₂ = 16 mm = 016.
L₁ = 28 mm = 028.
Shape 2 = 2.
a = 3,96 mm = 0396.
b = 5,16 mm = 0516
Order No = 2612.3.016.028.2.0396.0516

FIBRO

2601.
2611.

Precision Matrixes with and without collar conical

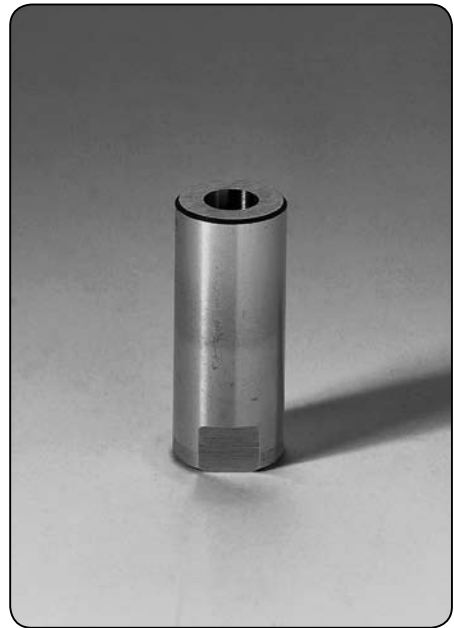
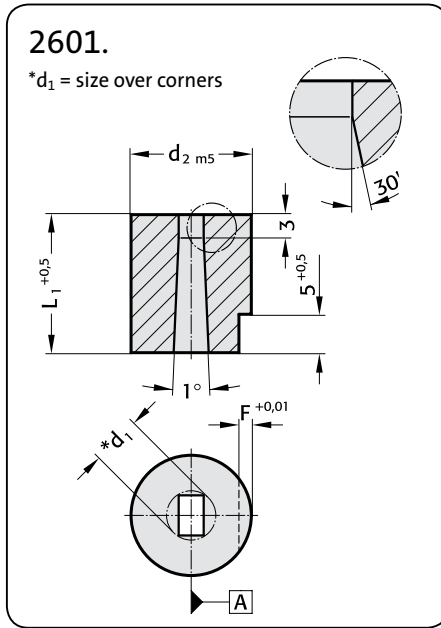
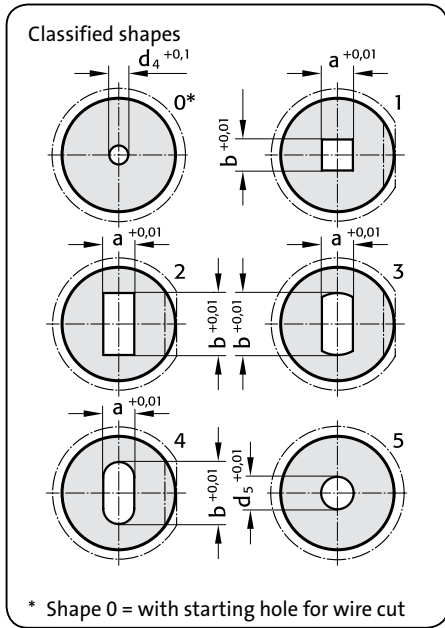

Material:
HS
Order No.: 2601. o. 2611.3.
Hardness: 64 ± 2 HRC

Execution:
Diameters d₂ precision ground;
face surfaces ground.
Key flats parallel with **A**
unless otherwise specified.

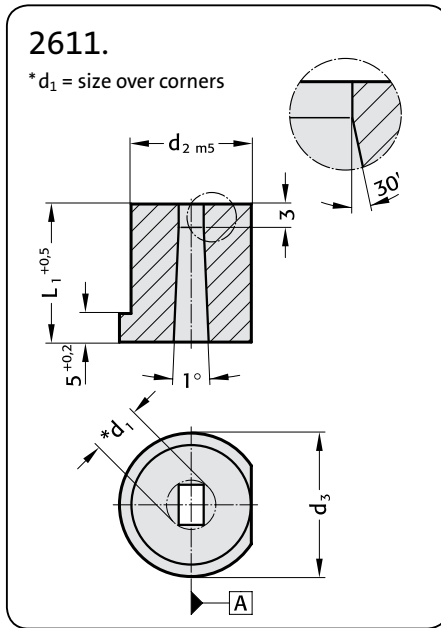

2601.

Size over corners				L ₁					
d ₁ , d ₅	d ₂	d ₄	F	16	19	22	25	28	32
1,8– 3,2	8	1,0	1,0	●	●	●	●	●	●
2,0– 5,0	10			●	●	●	●	●	●
3,0– 7,0	13	1,5	1,5	●	●	●	●	●	●
5,0– 8,0	16			●	●	●	●	●	●
7,0–11,0	20			●	●	●	●	●	●
11,0–16,0	25	2,5	2,5	●	●	●	●	●	●
16,0–19,0	32			●	●	●	●	●	●
19,0–28,0	40			●	●	●	●	●	●

Ordering Code (example):

Matrix = 2601.
Material HSS = 3.
d₂ = 16 mm = 016.
L₁ = 32 mm = 032.
Shape 2 = 2.
a = 3,96 mm = 0396.
b = 5,16 mm = 0516
Order No = 2601.3.016.032.2.0396.0516

2611.

Size over corners					L ₁					
d ₁ , d ₅	d ₂	d ₃	d ₄	F	16	19	22	25	28	32
1,8– 3,2	8	11	1,0		●	●	●	●	●	●
2,0– 5,0	10	13			●	●	●	●	●	●
3,0– 7,0	13	16	1,5		●	●	●	●	●	●
5,0– 8,0	16	19			●	●	●	●	●	●
7,0–11,0	20	23			●	●	●	●	●	●
11,0–16,0	25	28	2,5		●	●	●	●	●	●
16,0–19,0	32	35			●	●	●	●	●	●
19,0–28,0	40	43			●	●	●	●	●	●

Ordering Code (example):

Matrix = 2611.
Material HSS = 3.
d₂ = 16 mm = 016.
L₁ = 32 mm = 032.
Shape 2 = 2.
a = 3,96 mm = 0396.
b = 5,16 mm = 0516
Order No = 2611.3.016.032.2.0396.0516

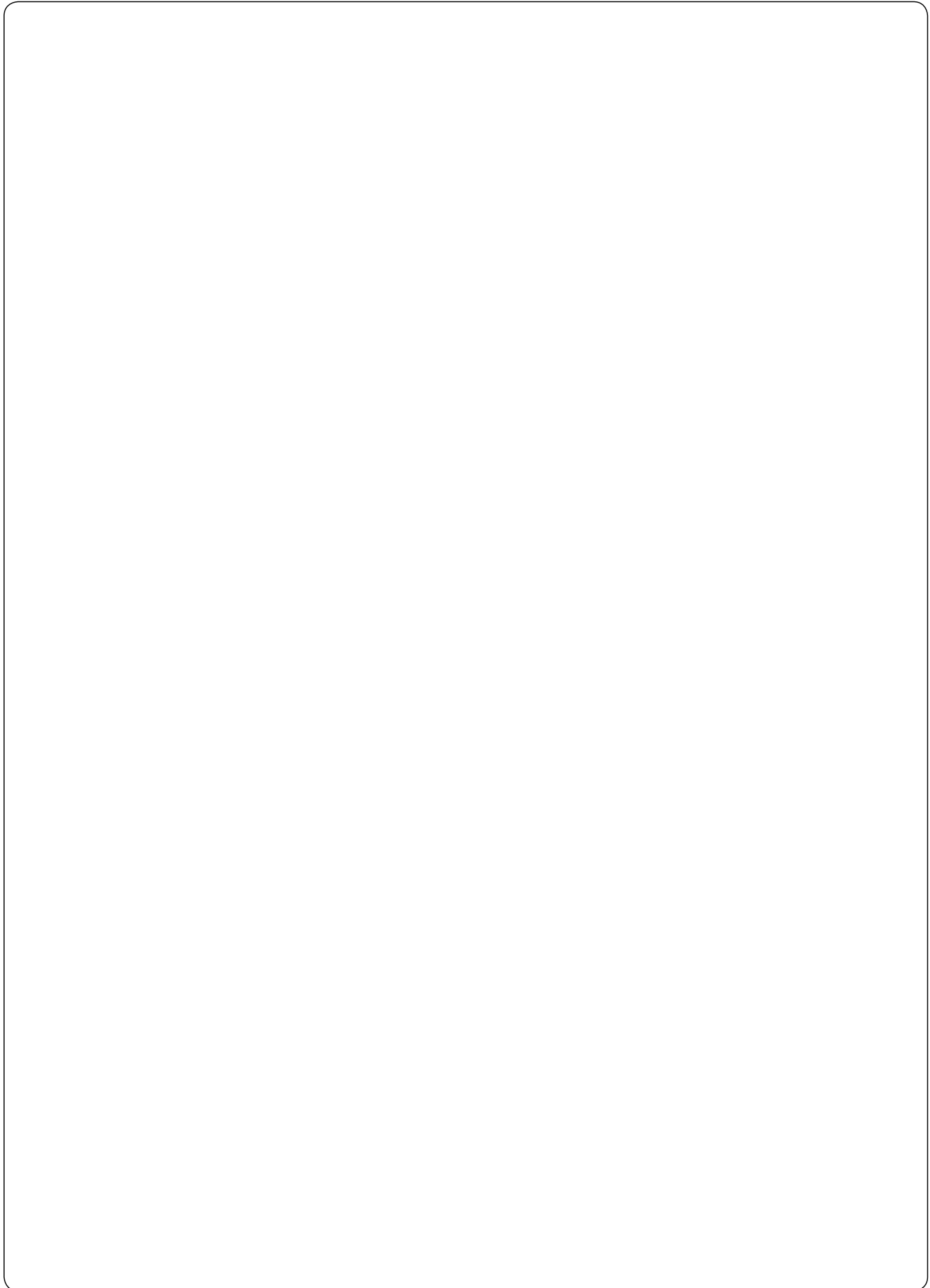

Standardised Special Shapes

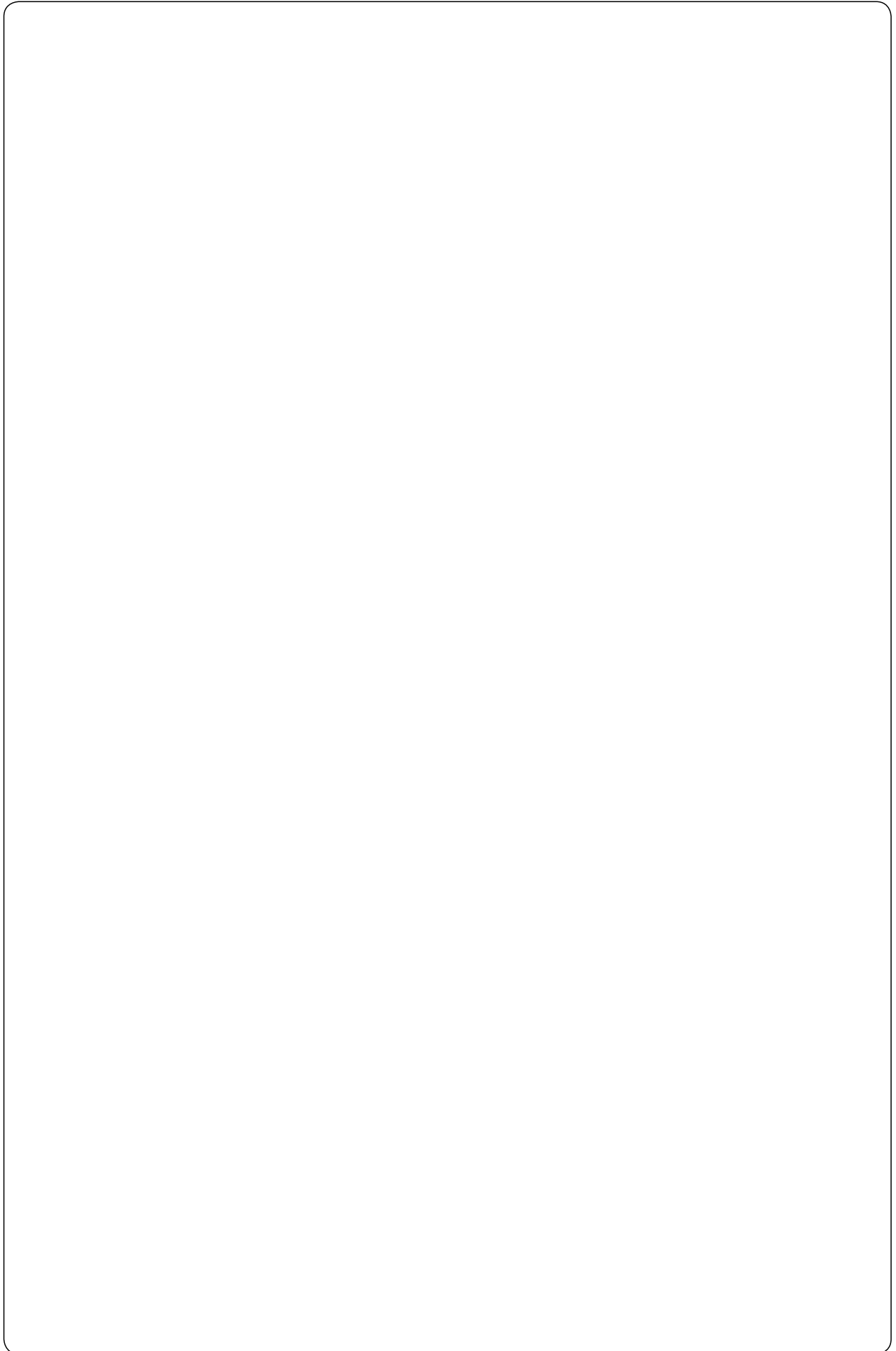

Ordering examples

Special shapes

Punches/Cutting bushes

2 2 9 2 . . F 2 4 . . .

Punch:
22 without ejector pin

Special shape

NB:
All the parameters
must be given for
special shapes!

Special shape F 24

You will find diameters and
lengths on the pages of
punches you have selected.

Type:	Order No
ISO 8020	= 1
ball-lock, light duty	= 2
ball-lock, heavy duty	= 3
ball-lock, larger cutting edge, light duty	= 4
ball-lock, larger cutting edge, heavy duty	= 5

View Punch

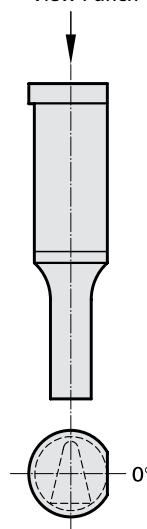

2 6 9 5 . . F 2 4 . . .

Matrixes

Special shape

NB:
All the parameters
must be given for
special shapes!

Special shape F 24

You will find diameters
and lengths on the pages
of cutting bushes you have
selected.

Type:	Order No
automotive	= 5
without shoulder ISO 8977	= 6
with shoulder ISO 8977	= 7

View Matrix

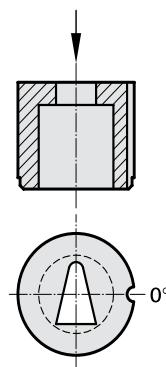

Standardised special shapes

90°

Round, flattened

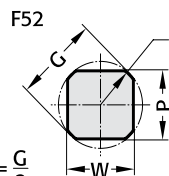
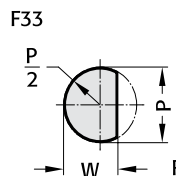
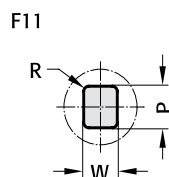
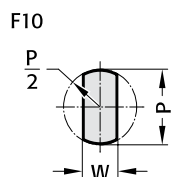

Key-hole shapes

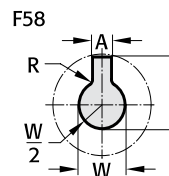
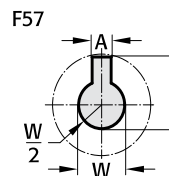
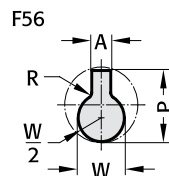
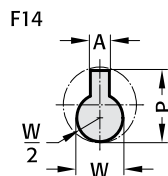
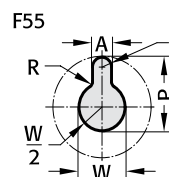
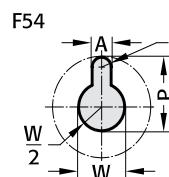
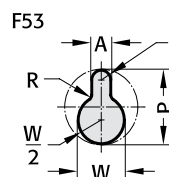
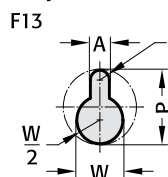

Various

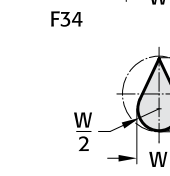
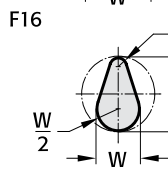
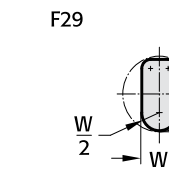
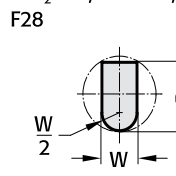
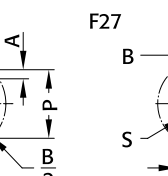
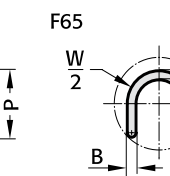
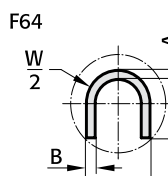
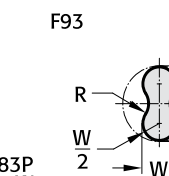
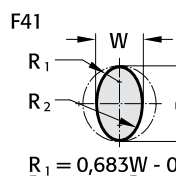

180° Triangles, trapezes

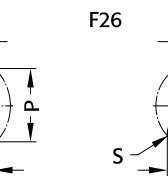
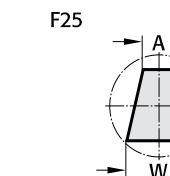
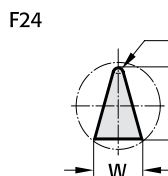
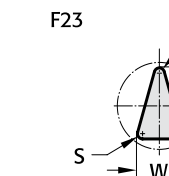
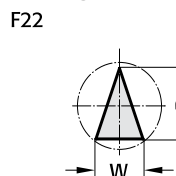

0°

Key-hole

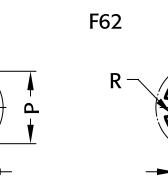
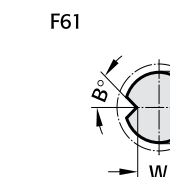
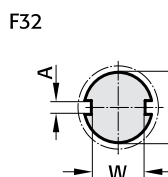
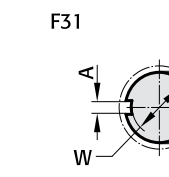
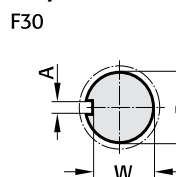

Polygons

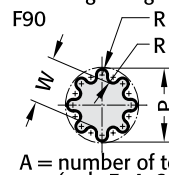
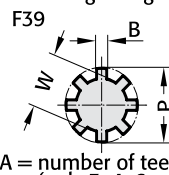
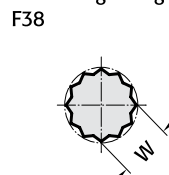
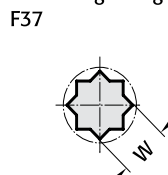
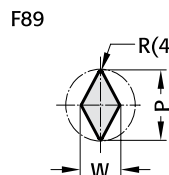
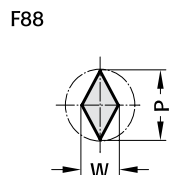
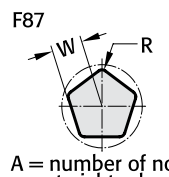
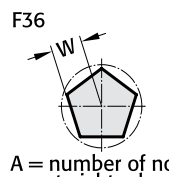
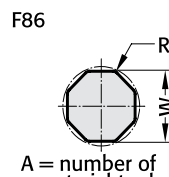
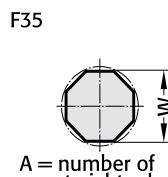
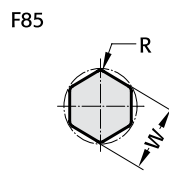
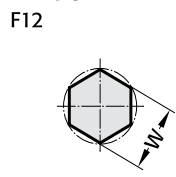

270°

90°

Multi key-hole shapes

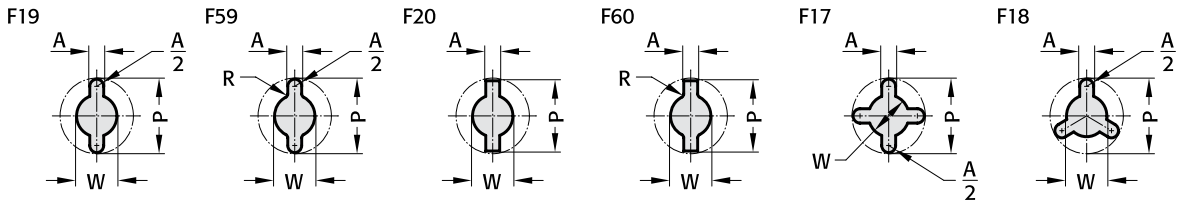

Double T-shapes

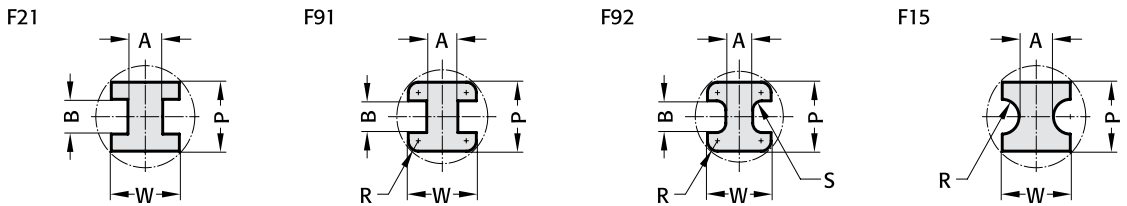

Simple T-shapes

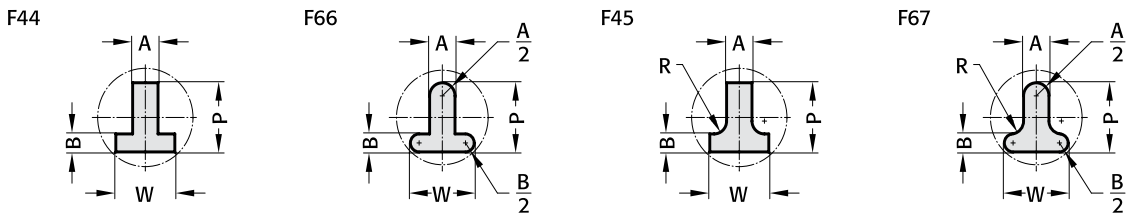

L-shapes

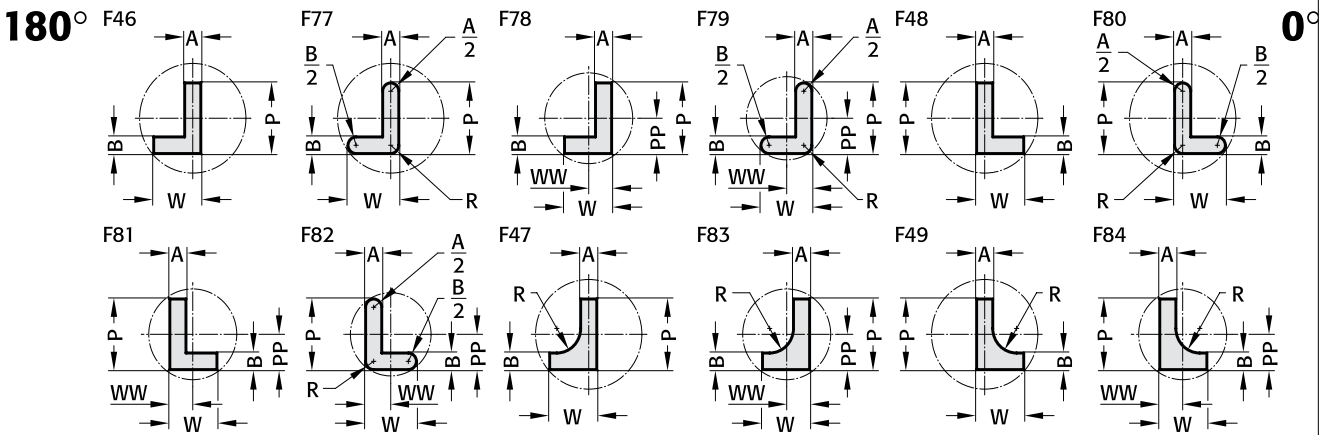

U-shapes

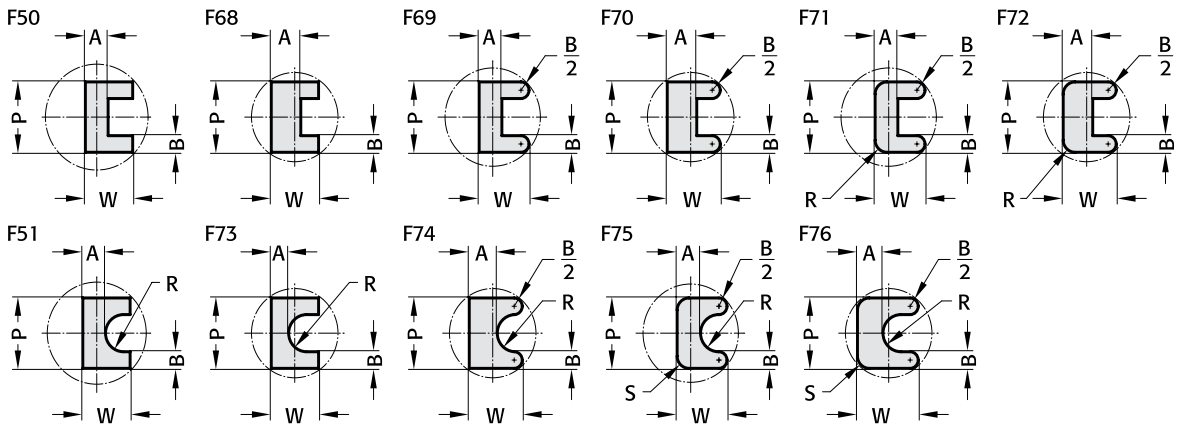

270°

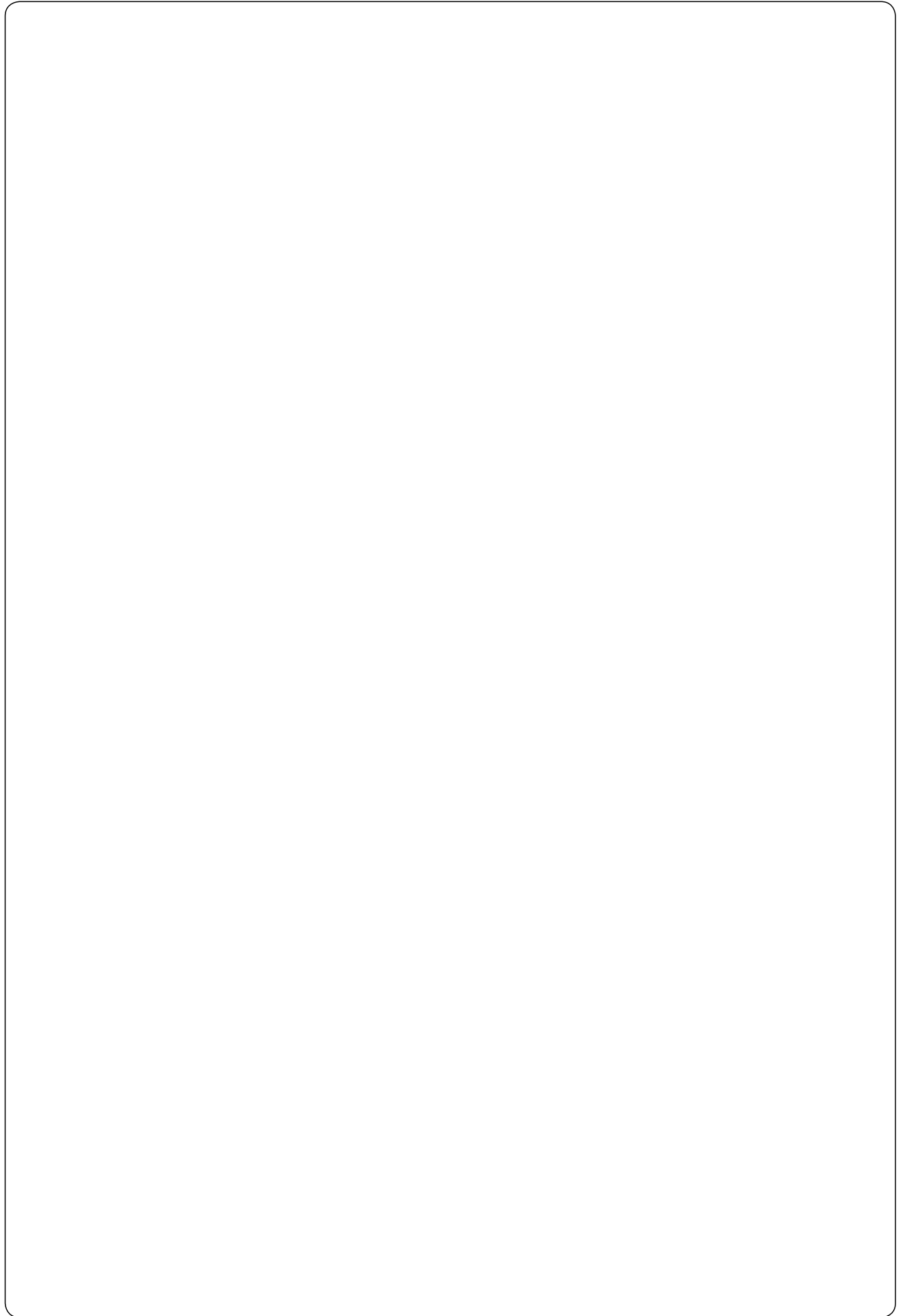

Ordering Code (example) Matrixes for Dynamic Stripper (DAE)

Note: See table for standard dimensions

Ordering Code (example):
2618.06.6E4.09

- Matrixes for Dynamic Stripper (DAE) (2618)
- Version: blank (pilot hole bore) (0)
- Type: without collar for Dynamic Stripper (DAE) (6)
- Diameter $d_2 = 16$ mm (6)
- Length: $l_1 = 25$ mm (E)
- Shape cutting length: $l = 5$ mm (4)
- $d_4 = 9$ mm (09)

Version	Order No
blank (pilot hole bore)	= 0

Type	Order No
without collar for Dynamic Stripper (DAE)	= 6
with collar for Dynamic Stripper (DAE)	= 7

Diameter d_2	Order No
13	= 5
16	= 6
20	= 7

Length l_1	Order Code character
25	= E

Shape cutting length l	Order No
5	= 4

Ordering Code (example):
2618.16.6E4.0431

- Matrixes for Dynamic Stripper (DAE) (2618)
- Version: Round (1)
- Type: without collar for Dynamic Stripper (DAE) (6)
- Diameter $d_2 = 16$ mm (6)
- Length: $l_1 = 25$ mm (E)
- Shape cutting length: $l = 5$ mm (4)
- Shape: Round $P = 4.31$ mm (0431)

Version	Order No
Round	= 1

Type	Order No
without collar for Dynamic Stripper (DAE)	= 6
with collar for Dynamic Stripper (DAE)	= 7

Diameter d_2	Order No
13	= 5
16	= 6
20	= 7

Length l_1	Order Code character
25	= E

Shape cutting length l	Order No
5	= 4

Dynamic Stripper (DAE)

2618.

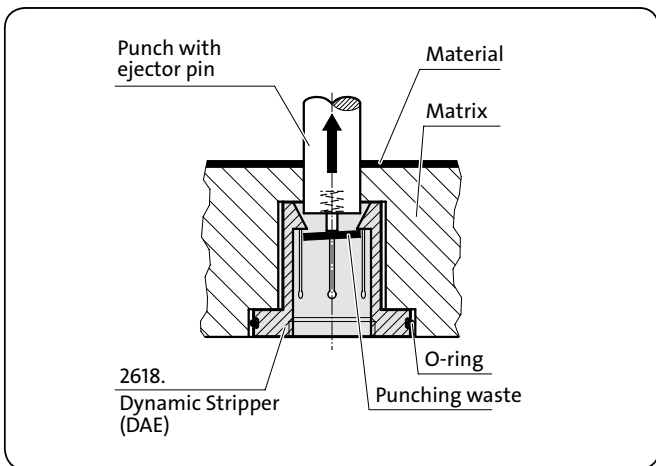
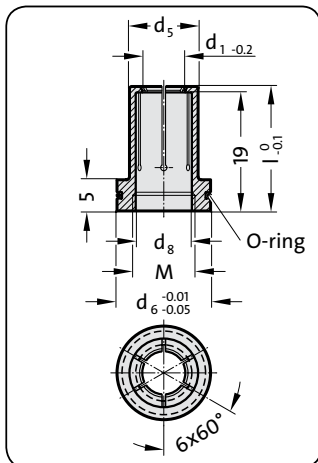

Mounting Example:

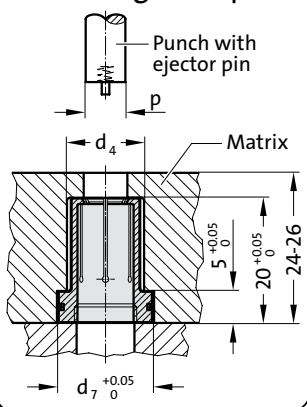

Mounting Example:

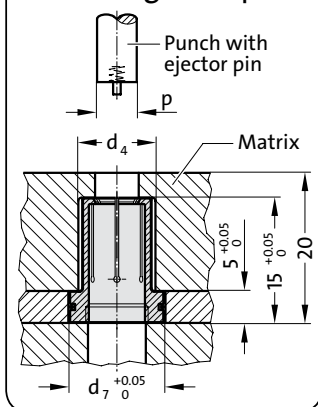

Material: Steel, hardened

Description:

The Dynamic Stripper is used in blanking tools for punching operations using material up to 2 mm thick. The Stripper is below the die. It is similar in shape to a segmented chuck. After the punching operation the punch enters the Stripper with the punch waste still attached.

The Dynamic Stripper opens up to receive the punch. On the return stroke the Dynamic Stripper strips the punch waste from the punch.

The stripping element diameter is manufactured 0.2 mm smaller than the diameter P of the punch. To ensure reliable stripping the minimum entry depth into the Dynamic Stripper must be no less than 1 mm.

The Dynamic Stripper can help to protect both the tool and the product from damage and also accelerate the production rate.

2618.

Cutting punch „P“ Gradation 0.01	Stripper „d1“ (Order ø)	Matrix					
		d5	d6	l	M	d4	d7
3.00 - 3.09	3.0	7	11	19.95	M6	8	11
3.10 - 3.19	3.1						
3.20 - 3.29	3.2						
3.30 - 3.39	3.3						
3.40 - 3.49	3.4						
3.50 - 3.59	3.5						
3.60 - 3.69	3.6						
3.70 - 3.79	3.7						
3.80 - 3.89	3.8						
3.90 - 3.99	3.9						
4.00 - 4.09	4.0						
4.10 - 4.19	4.1	8	12	19.95	M8	9	12
4.20 - 4.29	4.2						
4.30 - 4.39	4.3						
4.40 - 4.49	4.4						
4.50 - 4.59	4.5						
4.60 - 4.69	4.6						
4.70 - 4.79	4.7						
4.80 - 4.89	4.8						
4.90 - 4.99	4.9						
5.00 - 5.09	5.0						
5.10 - 5.19	5.1	9	13	19.95	M8	10	13
5.20 - 5.29	5.2						
5.30 - 5.39	5.3						
5.40 - 5.49	5.4						
5.50 - 5.59	5.5						
5.60 - 5.69	5.6						
5.70 - 5.79	5.7						
5.80 - 5.89	5.8						
5.90 - 5.99	5.9						
6.00 - 6.09	6.0						
6.10 - 6.19	6.1	10	14	19.95	M10	11	14
6.20 - 6.29	6.2						
6.30 - 6.39	6.3						
6.40 - 6.49	6.4						
6.50 - 6.59	6.5						
6.60 - 6.69	6.6						
6.70 - 6.79	6.7						
6.80 - 6.89	6.8						
6.90 - 6.99	6.9						
7.00 - 7.09	7.0						
7.10 - 7.19	7.1	11	15	19.95	M10	12	15
7.20 - 7.29	7.2						
7.30 - 7.39	7.3						
7.40 - 7.49	7.4						
7.50 - 7.59	7.5						
7.60 - 7.69	7.6						
7.70 - 7.79	7.7						
7.80 - 7.89	7.8						
7.90 - 7.99	7.9						
8.00 - 8.09	8.0						

Ordering Code (example):

Dynamic Stripper (DAE)	= 2618.
d5 = Ø 7 mm	= 07.
l = 19.95 mm	= 020.
d1 = 3.0 mm	= 0300
Order No	= 2618.07.020.0300

FIBRO Patent pending

2618.06.
2618.16.

**Matrixes without collar
for Dynamic Stripper (DAE)**

2618.06.

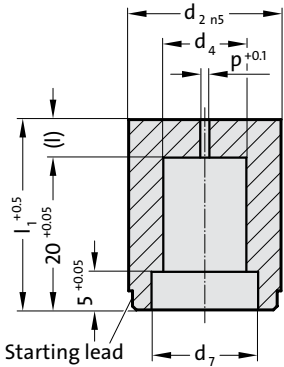

2618.06. with pilot hole bore

d ₂	d ₄	d ₇	P	l	l ₁
13	8	11	1.2	5	25
16	9	12	1.2	5	25
16	10	13	1.5	5	25
20	11	14	1.5	5	25
20	12	15	1.5	5	25

Material:

HSS
hardened: 62±2HRC

Execution:

Diameter d₂, starting lead and end faces ground.
Diameter P is a bored pilot hole for wire EDM.

Ordering Code (example):

see fold-out page E103

2618.16.

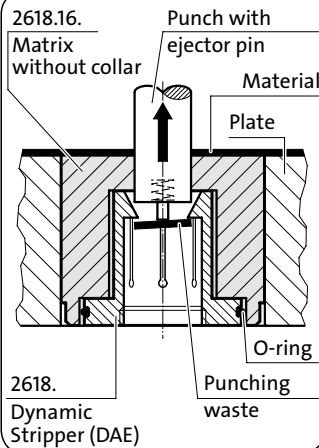
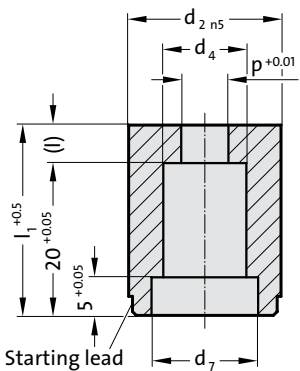

Mounting Example:

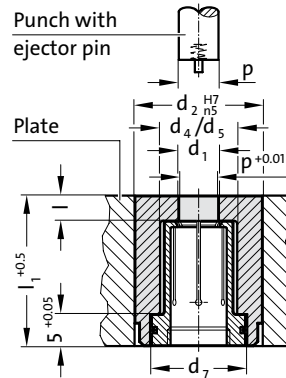

2618.16.

d ₂	d ₄	d ₇	l	l ₁	Matrix Gradation 0.01		d ₁ Gradation 0.1
					DAE	P	
13	8	11	5	25	7	3.00 - 4.29	3.0 - 4.0
16	9	12	5	25	8	4.30 - 5.29	4.1 - 5.0
16	10	13	5	25	9	5.30 - 6.29	5.1 - 6.0
20	11	14	5	25	10	6.30 - 7.29	6.1 - 7.0
20	12	15	5	25	11	7.30 - 8.29	7.1 - 8.0

Material:

Steel (HSS), hardened

Execution:

Diameter d₂, starting lead and end faces ground.

Note:

Order Dynamic Stripper (DAE) separately

Ordering Code (example):

see fold-out page E103

Patent pending

Matrixes with collar
for Dynamic Stripper (DAE)

FIBRO

2618.07.
2618.17.

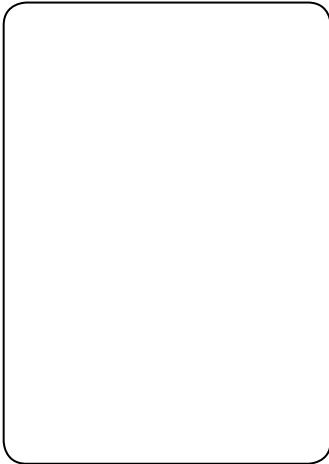
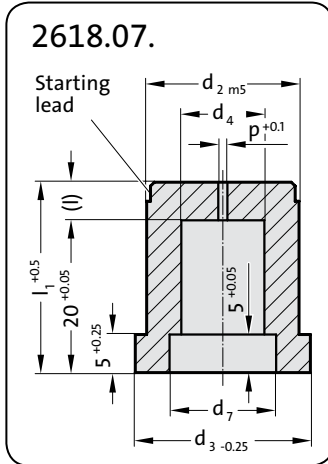

Material:

HSS
hardened: 62±2HRC

Execution:

Diameter d₂, starting lead and end faces ground.
Diameter P is a bored pilot hole for wire EDM.

Ordering Code (example):

see fold-out page E103

2618.07. with pilot hole bore

d ₂	d ₃	d ₄	d ₇	P	l	l ₁
13	16	8	11	1.2	5	25
16	19	9	12	1.2	5	25
16	19	10	13	1.5	5	25
20	23	11	14	1.5	5	25
20	23	12	15	1.5	5	25

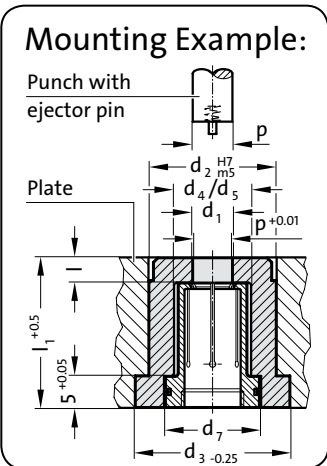
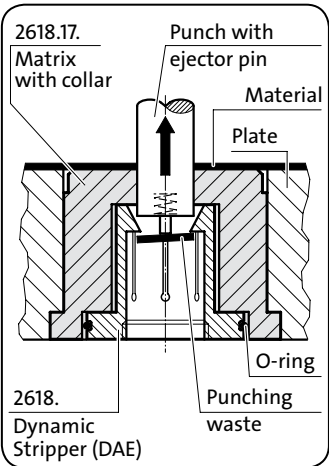
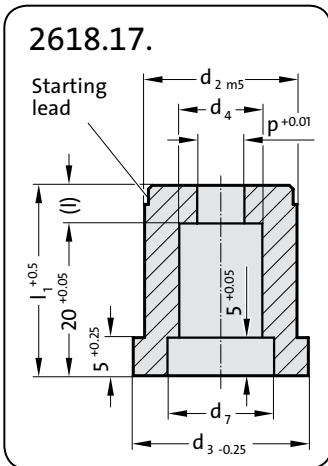

Material:

Steel (HSS), hardened

Execution:

Diameter d₂, starting lead and end faces ground.

Note:

Order Dynamic Stripper (DAE) separately

Ordering Code (example):

see fold-out page E103

2618.17.

d ₂	d ₃	d ₄	d ₇	l	l ₁	Matrix		d ₁
						Gradation 0.01	DAE	
13	16	8	11	5	25	3.00 - 4.29	7	3.0 - 4.0
16	19	9	12	5	25	4.30 - 5.29	8	4.1 - 5.0
16	19	10	13	5	25	5.30 - 6.29	9	5.1 - 6.0
20	23	11	14	5	25	6.30 - 7.29	10	6.1 - 7.0
20	23	12	15	5	25	7.30 - 8.29	11	7.1 - 8.0

Precision Retainers for Ball-Lock Punches

Triangle Precision Retainers for Ball-Lock Punches, light duty for Ball-Lock Punches, heavy duty

FIBRO
2664.05.
2664.06.

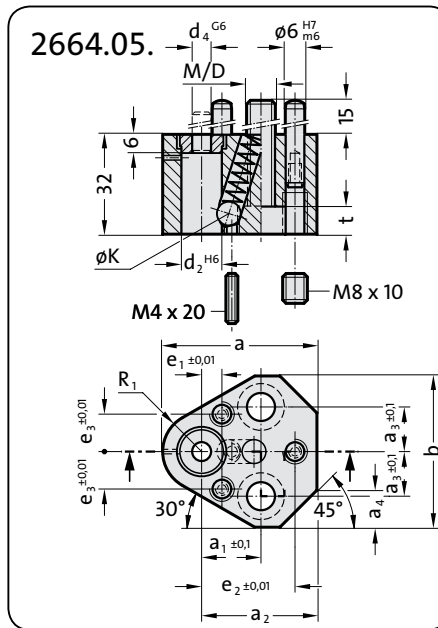
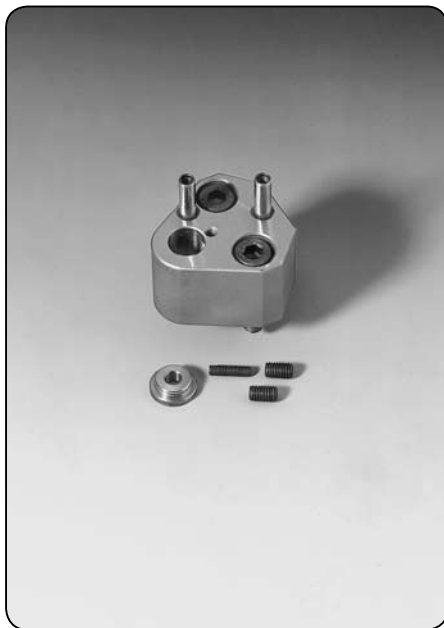

Execution:

Version for metal thicknesses <3 mm.

The punch locating hole d_2 is manufactured to a tolerance of ± 0.01 mm relative to the 6 stud holes H7. This ensures the interchangeability of the locating plate with other polygon versions.

Note:

Special punch retainers available to order.

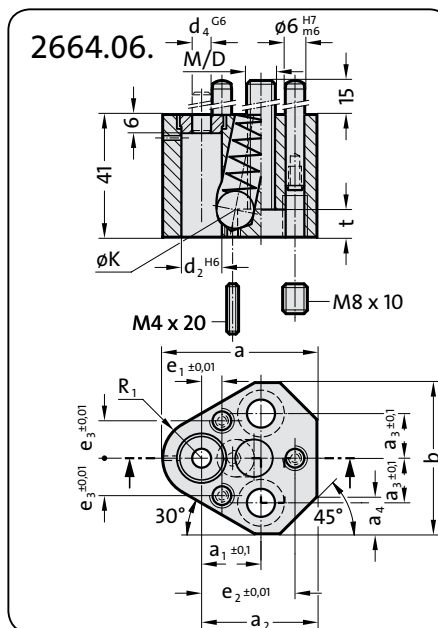
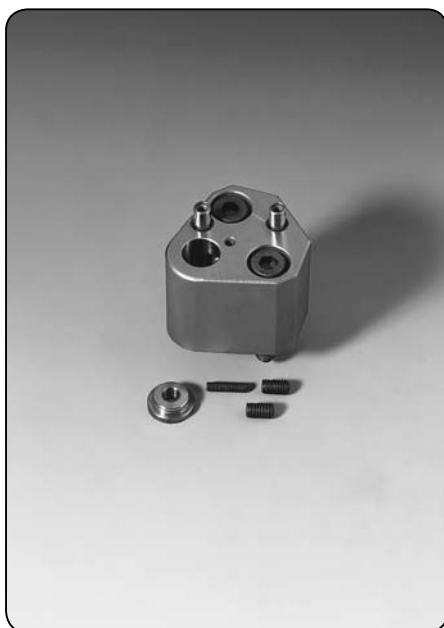

Execution:

Version for metal thicknesses >3 mm.

The punch locating hole d_2 is manufactured to a tolerance of ± 0.01 mm relative to the 6 stud holes H7. This ensures the interchangeability of the locating plate with other polygon versions.

Note:

Special punch retainers available to order.

2664.05.

d_2	10	13	16	20	25	32	38
d_4	6	6	6	6	6	6	6
M/D	8/9	8/9	8/9	10/11	12/13,5	12/13,5	12/13,5
a	43,5	49,5	52,5	59	68,5	68,5	76
a_1	19,05	19,05	19,05	19,05	23,82	23,82	27
a_2	34	37	38,5	42	46,5	46,5	50
a_3	11,12	14,27	15,87	17,47	19,84	19,84	24
a_4	10	12	13	14	16	16	18
b	41	48,5	51,5	56,5	64,5	64,5	72,5
e_1	7,5	6,5	6	5	7	7	10
e_2	26,92	29,97	31,75	33,53	40,64	40,64	43,99
e_3	9	12	13,5	16,5	22	22	26
ϕK	8	8	8	8	8	8	8
t	9	9	9	11	13	13	13
R_1	9,5	12,5	14	17	22	22	26

Ordering example:

Triangle retainer	= 2664.
for ball-lock punch, light duty	= 05.
$d_2 = \phi 13$ mm	= 13
Order number	= 2664.05.13

2664.06.

d_2	10	13	16	20	25	32	40
d_4	6	6	6	6	6	6	6
M/D	8/9	8/9	8/9	10/11	12/13,5	12/13,5	12/13,5
a	43,5	49,5	52,5	59	68,5	68,5	76
a_1	19,05	19,05	19,05	19,05	23,82	23,82	27
a_2	34	37	38,5	42	46,5	46,5	50
a_3	11,12	14,27	15,87	17,47	19,84	19,84	24
a_4	10	12	13	14	16	16	18
b	41	48,5	51,5	56,5	64,5	64,5	72,5
e_1	7,5	6,5	6	5	7	7	10
e_2	26,92	29,97	31,75	33,53	40,64	40,64	43,99
e_3	9	12	13,5	16,5	22	22	26
ϕK	10	12	12	12	12	12	12
t	9	9	9	11	13	13	13
R_1	9,5	12,5	14	17	22	22	26

Ordering example:

Triangle retainer	= 2664.
for ball-lock punch, heavy duty	= 06.
$d_2 = \phi 13$ mm	= 13
Order number	= 2664.06.13

FIBRO

2664.07.
2664.10.

Triangle Precision Retainers for Ball-Lock Punches, light duty for Ball-Lock Punches, heavy duty

Execution:

Version for metal thicknesses <3 mm.

The punch locating hole d_2 is manufactured to a tolerance of ± 0.01 mm relative to the 6 stud holes H7. This ensures the interchangeability of the locating plate with other polygon versions.

Note:

Special punch retainers available to order.

2664.07.

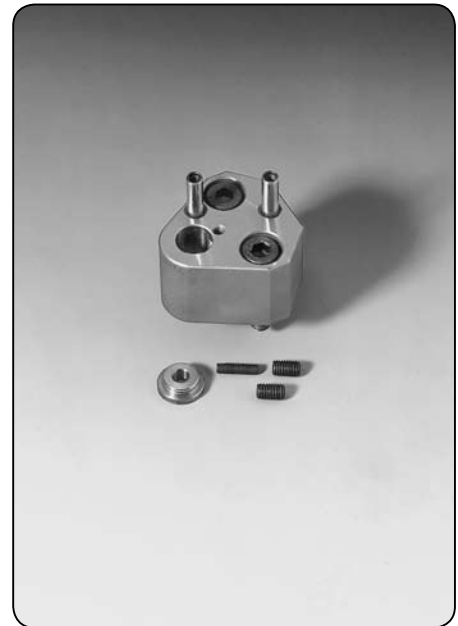
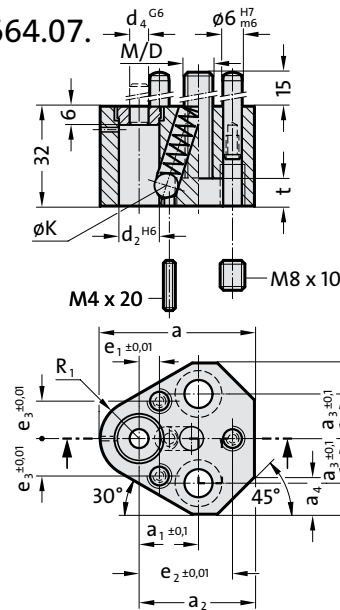

Execution:

Version for metal thicknesses >3 mm.

The punch locating hole d_2 is manufactured to a tolerance of ± 0.01 mm relative to the 6 stud holes H7. This ensures the interchangeability of the locating plate with other polygon versions.

Note:

Special punch retainers available to order.

2664.10.

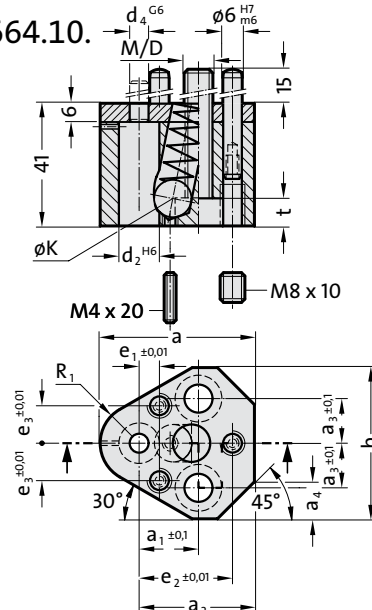

2664.07.

d_2	6
d_4	3
M/D	6/6,6
a	35
a_1	19,05
a_2	27
a_3	11,12
a_4	6
b	37,5
e_1	9,0
e_2	23
e_3	8
ØK	6
t	7
R_1	8

Ordering example:

Triangle retainer	=	2664.
light duty	=	07.
$d_2 = \text{Ø } 6 \text{ mm}$	=	06
Order number	=	2664.07.06

2664.10.

d_2	10	13	16	20	25	32	40
d_4	6	6	6	6	6	6	6
M/D	8/9	8/9	8/9	10/11	12/13,5	12/13,5	12/13,5
a	43,5	49,5	52,5	59	68,5	68,5	76
a_1	19,05	19,05	19,05	19,05	23,82	23,82	27
a_2	34	37	38,5	42	46,5	46,5	50
a_3	11,12	14,27	15,87	17,47	19,84	19,84	24
a_4	10	12	13	14	16	16	18
b	41	48,5	51,5	56,5	64,5	64,5	72,5
e_1	7,5	6,5	6	5	7	7	10
e_2	26,92	29,97	31,75	33,53	40,64	40,64	43,99
e_3	9	12	13,5	16,5	22	22	26
ØK	10	12	12	12	12	12	12
t	9	9	9	11	13	13	13
R_1	9,5	12,5	14	17	22	22	26

Ordering example:

Triangle retainer	=	2664.
heavy duty	=	10.
$d_2 = \text{Ø } 13 \text{ mm}$	=	13
Order number	=	2664.10.13

Triangle Precision Retainers
for Ball-Lock Punches, light duty
for Ball-Lock Punches, heavy duty

FIBRO
2664.08.
2664.09.

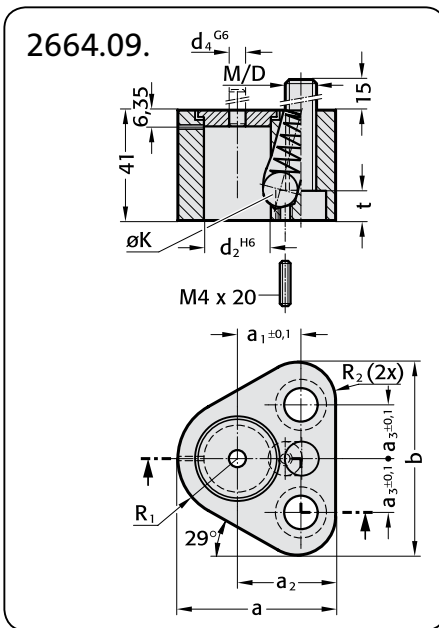
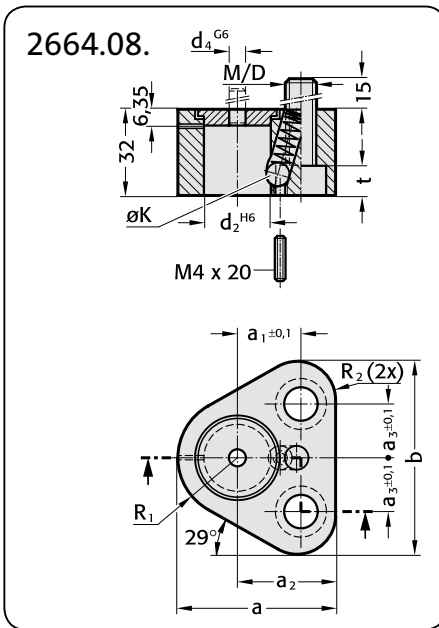

2664.08.

d ₂	10	13	16	20	25	32
d ₄	6	6	6	6	6	6
M/D	8	8	8	10	12	12
a	38,5	41,7	43,3	47,5	59,2	59,2
a ₁	19,05	19,05	19,05	19,05	23,82	23,82
a ₂	29	29	29	30	37	37
a ₃	11,12	14,27	15,87	17,47	19,84	19,84
b	40,61	47,93	51,59	57,93	70,85	70,85
ØK	8	8	8	8	8	8
t	9	9	9	11	13	13
R ₁	9,5	12,7	14,3	17,5	22,2	22,2
R ₂	9,5	9,5	9,5	11	15	15

Ordering example:

Triangle retainer for ball-lock punch	= 2664.
light duty	= 08.
d ₂ = Ø 20 mm	= 20
Order No	= 2664.08.20

2664.09.

d ₂	10	13	16	20	25	32
d ₄	6	6	6	6	6	6
M/D	8	8	8	10	12	12
a	38,5	41,7	43,3	47,5	59,2	59,2
a ₁	19,05	19,05	19,05	19,05	23,82	23,82
a ₂	29	29	29	30	37	37
a ₃	11,12	14,27	15,87	17,47	19,84	19,84
b	40,61	47,93	51,59	57,93	70,85	70,85
ØK	10	12	12	12	12	12
t	9	9	9	11	13	13
R ₁	9,5	12,7	14,3	17,5	22,2	22,2
R ₂	9,5	9,5	9,5	11	15	15

Ordering example:

Triangle retainer for ball-lock punch	= 2664.
heavy duty	= 09.
d ₂ = Ø 20 mm	= 20
Order No	= 2664.09.20

2192.10. 236.1. 2666.04. 2192.72. 2666.06. 2666.01. 2666.03. 2192.72.

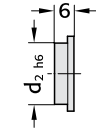
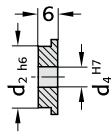
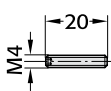
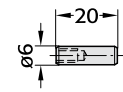
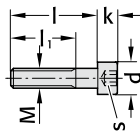

Retainer	Ø d _i	Socket head cap screw	Dowel pin	Ball	Ball release pin	Spring	Pressure disk for centring pin	Pressure Disc	Pin screw
2664.05.	10	2192.10.08.035	236.1.0600.020	2666.04.008	2192.72.04.020	2666.06.008	2666.01.10	2666.03.10	2192.72.08.008
	13	2192.10.08.035	236.1.0600.020	2666.04.008	2192.72.04.020	2666.06.008	2666.01.13	2666.03.13	2192.72.08.008
	16	2192.10.08.035	236.1.0600.020	2666.04.008	2192.72.04.020	2666.06.008	2666.01.16	2666.03.16	2192.72.08.008
	20	2192.10.10.035	236.1.0600.020	2666.04.008	2192.72.04.020	2666.06.008	2666.01.20	2666.03.20	2192.72.08.008
	25	2192.10.12.035	236.1.0600.020	2666.04.008	2192.72.04.020	2666.06.008	2666.01.25	2666.03.25	2192.72.08.008
	32	2192.10.12.035	236.1.0600.020	2666.04.008	2192.72.04.020	2666.06.008	2666.01.32	2666.03.32	2192.72.08.008
	38	2192.10.12.035	236.1.0600.020	2666.04.008	2192.72.04.020	2666.06.008	2666.01.38	2666.03.38	2192.72.08.008
2664.06./10.	10	2192.10.08.040	236.1.0600.020	2666.04.010	2192.72.04.020	2666.06.010	2666.01.10	2666.03.10	2192.72.08.008
	13	2192.10.08.040	236.1.0600.020	2666.04.012	2192.72.04.020	2666.06.012	2666.01.13	2666.03.13	2192.72.08.008
	16	2192.10.08.040	236.1.0600.020	2666.04.012	2192.72.04.020	2666.06.012	2666.01.16	2666.03.16	2192.72.08.008
	20	2192.10.10.050	236.1.0600.020	2666.04.012	2192.72.04.020	2666.06.012	2666.01.20	2666.03.20	2192.72.08.008
	25	2192.10.12.050	236.1.0600.020	2666.04.012	2192.72.04.020	2666.06.012	2666.01.25	2666.03.25	2192.72.08.008
	32	2192.10.12.050	236.1.0600.020	2666.04.012	2192.72.04.020	2666.06.012	2666.01.32	2666.03.32	2192.72.08.008
	40	2192.10.12.050	236.1.0600.020	2666.04.012	2192.72.04.020	2666.06.012	2666.01.40	2666.03.38	2192.72.08.008
2664.07.	6	2192.10.06.035	236.1.0600.020	2666.04.006	2192.72.04.020	2666.06.006	2666.01.06	2666.03.06	2192.72.08.008
2664.08.	10	2192.10.08.035	236.1.0600.020	2666.04.008	2192.72.04.020	2666.06.008	2666.01.10	2666.03.10	2192.72.08.008
	13	2192.10.08.035	236.1.0600.020	2666.04.008	2192.72.04.020	2666.06.008	2666.01.13	2666.03.13	2192.72.08.008
	16	2192.10.08.035	236.1.0600.020	2666.04.008	2192.72.04.020	2666.06.008	2666.01.16	2666.03.16	2192.72.08.008
	20	2192.10.10.035	236.1.0600.020	2666.04.008	2192.72.04.020	2666.06.008	2666.01.20	2666.03.20	2192.72.08.008
	25	2192.10.12.035	236.1.0600.020	2666.04.008	2192.72.04.020	2666.06.008	2666.01.25	2666.03.25	2192.72.08.008
	32	2192.10.12.035	236.1.0600.020	2666.04.008	2192.72.04.020	2666.06.008	2666.01.32	2666.03.32	2192.72.08.008
2664.09.	10	2192.10.08.040	236.1.0600.020	2666.04.010	2192.72.04.020	2666.06.010	2666.01.10	2666.03.10	2192.72.08.008
	13	2192.10.08.040	236.1.0600.020	2666.04.012	2192.72.04.020	2666.06.012	2666.01.13	2666.03.13	2192.72.08.008
	16	2192.10.08.040	236.1.0600.020	2666.04.012	2192.72.04.020	2666.06.012	2666.01.16	2666.03.16	2192.72.08.008
	20	2192.10.10.040	236.1.0600.020	2666.04.012	2192.72.04.020	2666.06.012	2666.01.20	2666.03.20	2192.72.08.008
	25	2192.10.12.040	236.1.0600.020	2666.04.012	2192.72.04.020	2666.06.012	2666.01.25	2666.03.25	2192.72.08.008
	32	2192.10.12.040	236.1.0600.020	2666.04.012	2192.72.04.020	2666.06.012	2666.01.32	2666.03.32	2192.72.08.008
Ball release tool		Hook shape	straight	straight with threaded tip					

2666.05.01

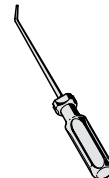

2666.05.02

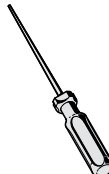

2666.05.03

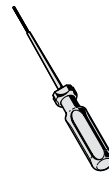

**Square Precision Retainers
for Ball-Lock Punches, light duty**

**2661.07.
2661.08.**

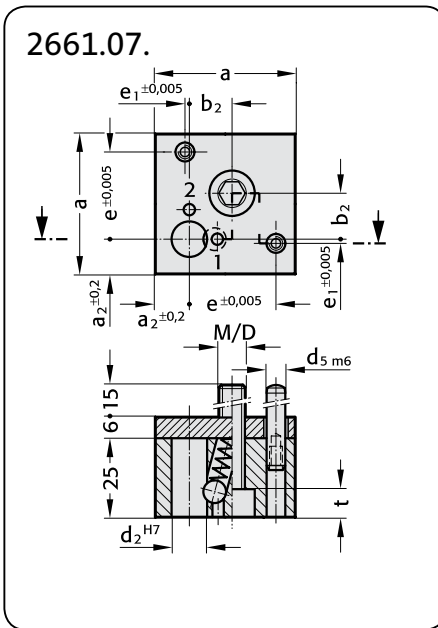

Execution:
The centres of the pinholes d_5 are the reference points for the position of the punch bore.
The dimensions e and e_1 have a tolerance of $\pm 0,005$ mm.
The square ball-lock retainers are interchangeable.
The order must specify position 1 or 2 for the locking ball.
Ball channel horizontal = 1
Ball channel vertical = 2

Note:
Supplied with dowel pins and screws
DIN EN ISO 4762.

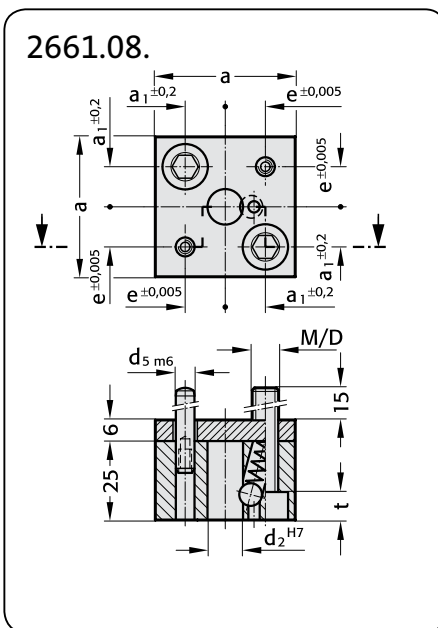
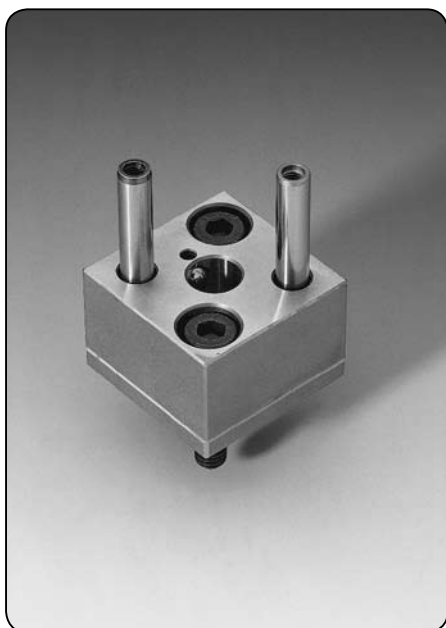

Execution:
The centres of the pinholes d_5 are the reference points for the position of the punch bore.
The e -dimensions have a tolerance of $\pm 0,005$ mm.
The square ball-lock retainers are interchangeable.

Note:
Supplied with dowel pins and screws
DIN EN ISO 4762.

2661.07.

d_2	d_5	M/D	a	a_2	b_2	e	e_1	t
10	8	8/9	45	11	15	28	1	9
13								
16								
20	10	10/11	56	17	18	32	5	11
25								

Ordering code (example):

Square Retainer	= 2661.
for Ball-Lock Punch	= 07.
$d_2 = \varnothing 20$ mm	= 20.
Vertical ball race	= 2
Order No	= 2661.07.20.2

2661.08.

d_2	d_5	M/D	a	a_1, e	t
6	8	8/9	45	13	9
10					
13					
16					
20	10	10/11	56	16	11
25		12/13,5	63	20	13

Ordering code (example):

Square Retainer	= 2661.
for Ball-Lock Punch	= 08.
$d_2 = \varnothing 20$ mm	= 20
Order No	= 2661.08.20

Material:

Punch plate case-hardened 740±40 HV 10
Pressure plate hardened 60 +2 HRC

Execution:

The centres of the pin holes d_5 are the reference points for the position of the punch bore.

The dimensions e , e_1 and e_2 have a tolerance of ± 0,005 mm.

The rectangular ball-lock retainers are interchangeable.

Note:

Supplied with dowel pins and screws
DIN EN ISO 4762.

2662.05.

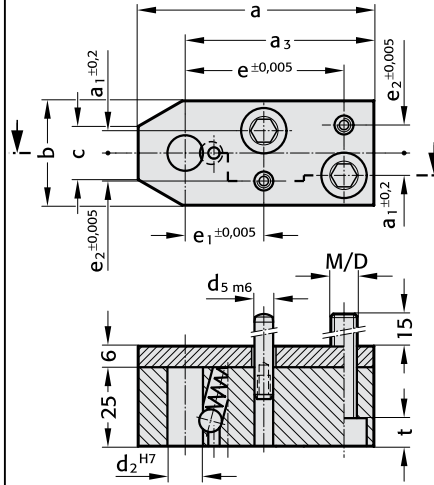

2662.05.

d_2	d_5	M/D	a	a_3	a_1	b	e	e_1	e_2	c	t
6	8	8/9	75	60	7	32	50	25	9	16	9
10											
13											
16											
20	10	10/11	85	63	9	40	53	28	11	20	11
25											

Ordering code (example):

Rectangular Retainer	= 2662.
for Ball-Lock Punch	= 05.
$d_2 = \varnothing 20$ mm	= 20
Order No	= 2662.05.20

ACCU-LOCK Fixture Device for Ball-Lock Punches

light duty
heavy duty

FIBRO

2668.2.

2668.3.

2668.2./2668.3.

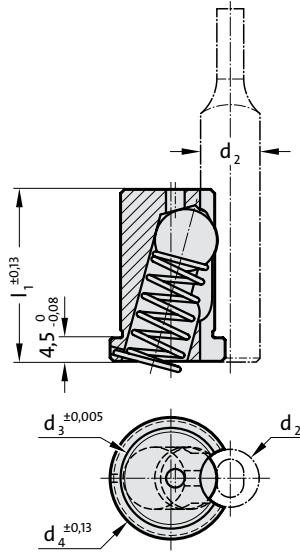

2668.2.

Order code	Cutting punch- \varnothing "d ₂ "	d ₃	d ₄	l ₁
2668.2.06	6	12	14.6	25.7
2668.2.10	10	14	16.6	25.7
2668.2.13	13	14	16.6	25.7
2668.2.16	16	14	16.6	25.7
2668.2.20	20	16	18.6	25.7
2668.2.25	25	16	18.6	25.7
2668.2.32	32	16	18.6	25.7
2668.2.38	38	16	18.6	25.7

2666.05.02
Ball release tool, straight

2668.3.

Order code	Cutting punch- \varnothing "d ₂ "	d ₃	d ₄	l ₁
2668.3.10	10	16	19.6	34.7
2668.3.13	13	20	24.6	34.7
2668.3.16	16	20	24.6	34.7
2668.3.20	20	20	24.6	34.7
2668.3.25	25	20	24.6	34.7
2668.3.32	32	20	24.6	34.7
2668.3.40	40	20	24.6	34.7

2666.05.02
Ball release tool, straight



Typical Application:



Mounting Example:

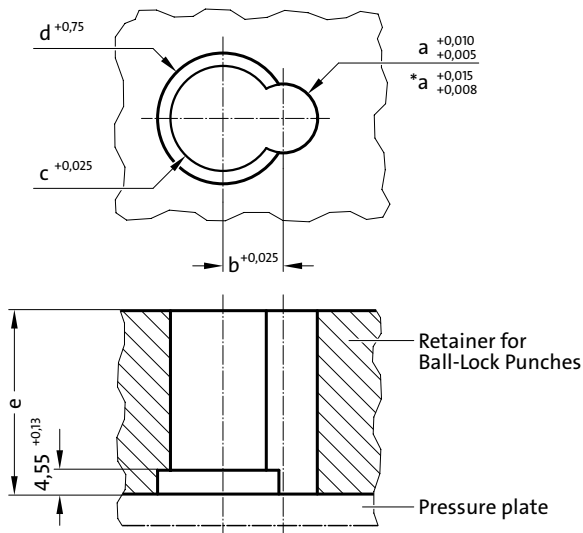

Mounting dimensions for 2668.2. / 2668.3.

Order-No.	a	b	c	d	e
2668.2.06	6	6.5	12.013	15.0	25.7
2668.2.10	10	9.0	14.013	17.0	25.7
2668.2.13	13	10.5	14.013	17.0	25.7
2668.2.16	16	12.0	14.013	17.0	25.7
2668.2.20	20	14.0	16.013	19.0	25.7
2668.2.25	25	16.5	16.013	19.0	25.7
2668.2.32	*32	20.0	16.013	19.0	25.7
2668.2.38	*38	23.0	16.013	19.0	25.7
2668.3.10	10	10.0	16.013	20.0	34.7
2668.3.13	13	11.5	20.013	25.0	34.7
2668.3.16	16	13.0	20.013	25.0	34.7
2668.3.20	20	15.0	20.013	25.0	34.7
2668.3.25	25	17.5	20.013	25.0	34.7
2668.3.32	*32	21.0	20.013	25.0	34.7
2668.3.40	*40	25.0	20.013	25.0	34.7

Precision Retainers ISO

Triangle Precision Retainers,
for round Punches, ISO 8020
for Profile Punches, ISO 8020

FIBRO
2664.02.
2664.04.

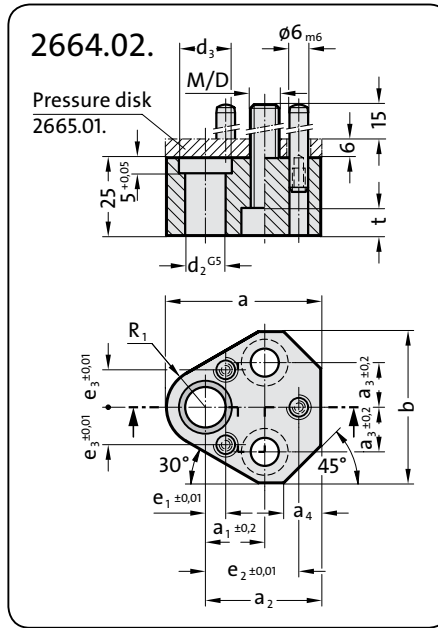

Execution:

The centres of the pinholes d_3 are the reference points for the position of the punch bore.
The dimensions e_1 , e_2 and e_3 have a tolerance of ± 0.01 mm.
The triangle retainers are interchangeable.

Note:

Pressure plate 2665.01 to be ordered separately for the receiving punch plate.

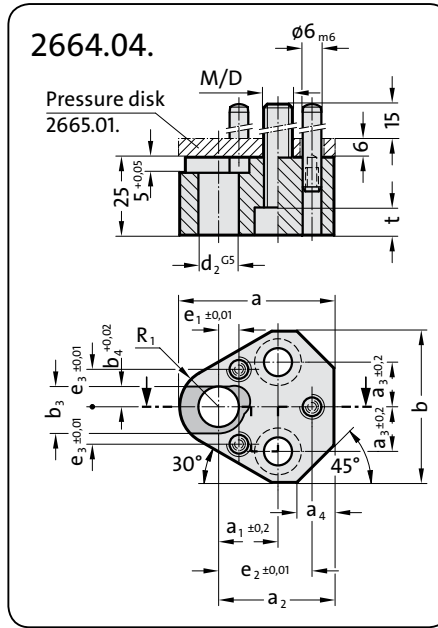
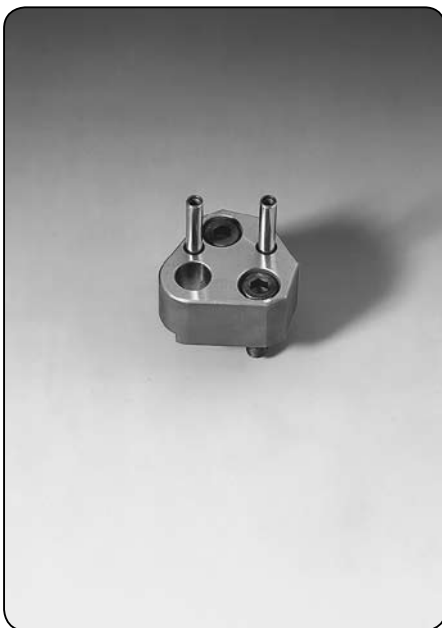

Execution:

The centres of the pinholes d_3 are the reference points for the position of the punch bore.
The dimensions e_1 , e_2 and e_3 have a tolerance of ± 0.01 mm.
The triangle retainers are interchangeable.

Note:

Pressure plate 2665.01 to be ordered separately for the receiving punch plate.

2664.02.

d_2	10	13	16	20	25	32
d_3	14	17	20	24	29	36
M/D	8/9	8/9	8/9	10/11	12/13,5	12/13,5
a	43,5	49,5	52,5	59	68,5	68,5
a_1	19,05	19,05	19,05	19,05	23,82	23,82
a_2	34	37	38,5	42	46,5	46,5
a_3	11,12	14,27	15,87	17,47	19,84	19,84
a_4	10	12	13	14	16	16
b	41,0	48,5	51,5	56,5	64,5	64,5
e_1	7,5	6,5	6	5	7	7
e_2	26,92	29,97	31,75	33,53	40,64	40,64
e_3	9	12	13,5	16,5	22	22
t	9	9	9	11	13	13
R_1	9,5	12,5	14	17	22	22

Ordering example:

Triangle retainer	= 2664.
for round Punch, ISO 8020	= 02.
$d_2 = \varnothing 13$ mm	= 13
Order number	= 2664.02.13

2664.04.

d_2	10	13	16	20	25	32
M/D	8/9	8/9	8/9	10/11	12/13,5	12/13,5
a	43,5	49,5	52,5	59	68,5	68,5
a_1	19,05	19,05	19,05	19,05	23,82	23,82
a_2	34	37	38,5	42	46,5	46,5
a_3	11,12	14,27	15,87	17,47	19,84	19,84
a_4	10	12	13	14	16	16
b	41,0	48,5	51,5	56,5	64,5	64,5
b_3	12	15	18	23	28	35
b_4	5	6,5	8	10	12,5	16
e_1	7,5	6,5	6	5	7	7
e_2	26,92	29,97	31,75	33,53	40,64	40,64
e_3	9	12	13,5	16,5	22	22
t	9	9	9	11	13	13
R_1	9,5	12,5	14	17	22	22

Ordering example:

Triangle retainer	= 2664.
for Profile Punch, ISO 8020	= 04.
$d_2 = \varnothing 13$ mm	= 13
Order number	= 2664.04.13

Accessories for Precision Retainers,
triangular, for Punches, to ISO 8020

2192.10.

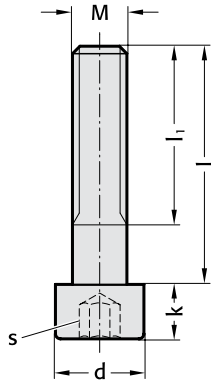

236.1.

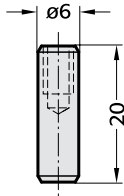

2192.72.

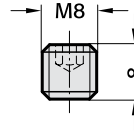

2665.01.

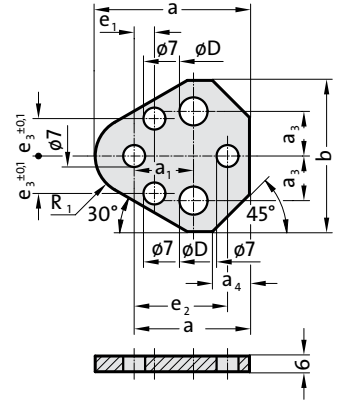

Retainer	Ø d ₂	Socket head cap screw	Dowel pin	Pin screw	Pressure plate
2664.02./04.	10	2192.10.08.035	236.1.0600.020	2192.72.08.008	2665.01.10
	13	2192.10.08.035	236.1.0600.020	2192.72.08.008	2665.01.13
	16	2192.10.08.035	236.1.0600.020	2192.72.08.008	2665.01.16
	20	2192.10.10.035	236.1.0600.020	2192.72.08.008	2665.01.20
	25	2192.10.12.035	236.1.0600.020	2192.72.08.008	2665.01.25
	32	2192.10.12.035	236.1.0600.020	2192.72.08.008	2665.01.32

**Square Precision Retainers
for Punches to ISO 8020**

**2661.01.
2661.02.**

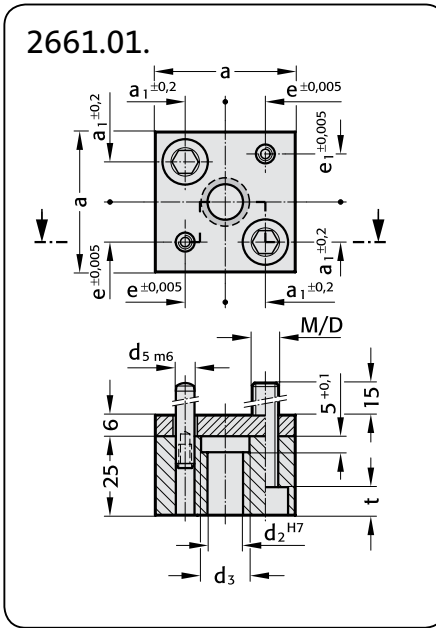
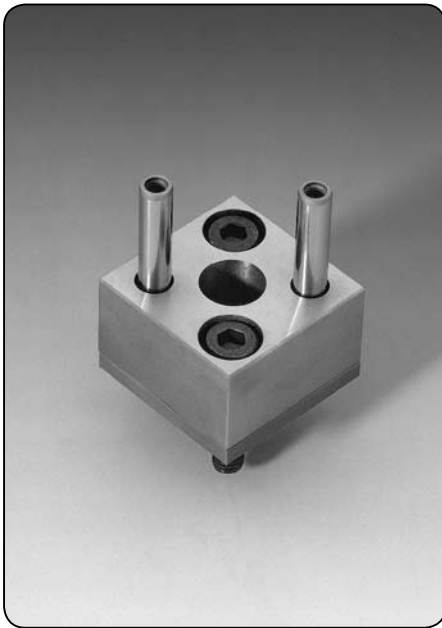

Execution:

The centres of the pinholes d_5 are the reference points for the position of the punch bore.
The dimensions e and e_1 have a tolerance of $\pm 0,005$ mm.
The square retainers are interchangeable.

Note:

Supplied with dowel pins and screws
DIN EN ISO 4762.

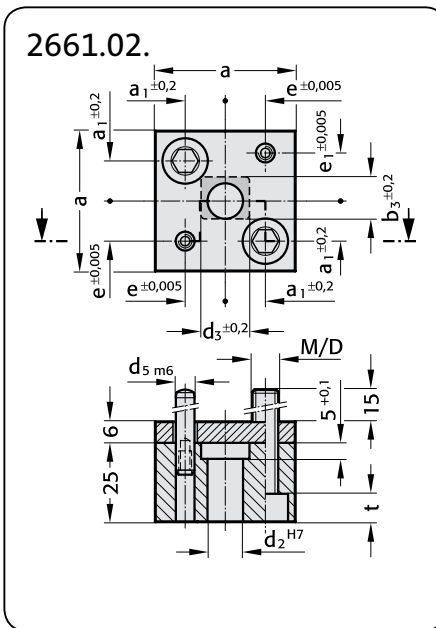

Execution:

The centres of the pinholes d_5 are the reference points for the position of the punch bore.
The dimensions e and e_1 have a tolerance of $\pm 0,005$ mm.
The square retainers are interchangeable.

Note:

Supplied with dowel pins and screws
DIN EN ISO 4762.

2661.01.

d_2	d_3	d_5	M/D	a	a_1, e	e_1	t
6	10	8	8/9	45	13	15,5	9
8	12						
10	14						
13	17						
16	20						
20	25	10	10/11	56	16	19	11
25	30		12/13,5	63	20	22,5	13

Ordering code (example):

Square Retainer = 2661.
for punch to ISO 8020 = 01.
 $d_2 = \varnothing 13$ mm = 13
Order No = 2661.01.13

2661.02.

d_2	d_3	d_5	M/D	a	a_1, e	e_1	b_3	t
6	10	8	8/9	45	13	15,5	8	9
8	12						10	
10	14						12	
13	17						15	
16	20						18	
20	25	10	10/11	56	16	19	22,5	11
25	30		12/13,5	63	20	22,5	27,5	13

Ordering code (example):

Square Retainer = 2661.
for punch to ISO 8020 = 02.
 $d_2 = \varnothing 20$ mm = 20
Order No = 2661.02.20

FIBRO

2662.01.
2662.02.

Rectangular Precision Retainers for Punches to ISO 8020

Execution:

The centres of the pinholes d_5 are the reference points for the position of the punch bore.
The dimensions b , e_1 and e_2 have a tolerance of $\pm 0,005$ mm.
The rectangular retainers are interchangeable.

Note:

Supplied with dowel pins and screws
DIN EN ISO 4762.

2662.01.

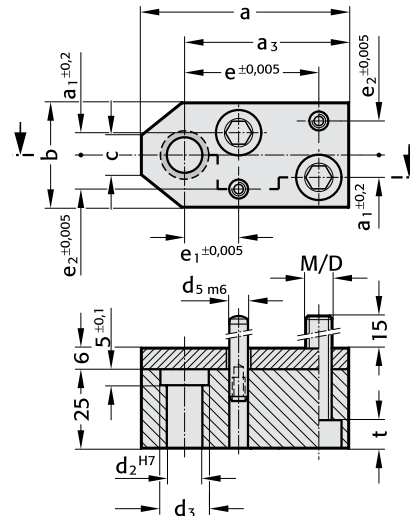

Execution:

The centres of the pinholes d_5 are the reference points for the position of the punch bore.
The dimensions e , e_1 and e_2 have a tolerance of $\pm 0,005$ mm.
The rectangular retainers are interchangeable.

Note:

Supplied with dowel pins and screws
DIN EN ISO 4762.

2662.02.

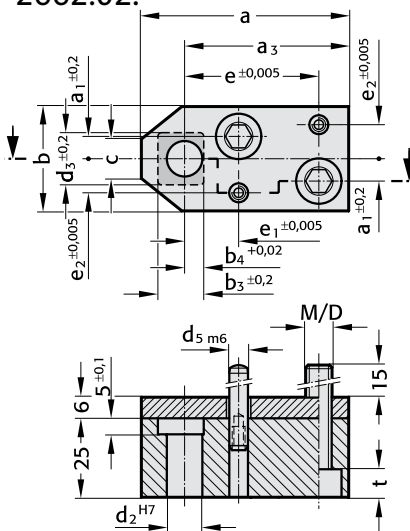

2662.01.

d_2	d_3	d_5	M/D	a	a_1	a_3	b	e	e_1	e_2	c	t
6	10	8	8/9	60	7	50	32	40	15	9	11	9
8	12											
10	14											
13	17			67		53		43	18		16	
16	20											
20	25	10	10/11	80	9	60	40	50	25	11	22	11
25	30											

2662.02.

d_2	d_3	d_5	M/D	a	a_1	a_3	b	b_3	b_4	e	e_1	e_2	c	t
6	10	8	8/9	60	7	50	32	8	3	40	15	9	11	9
8	12							10	4					
10	14							12	5					
13	17			67		53		15	6,5	43	18		16	
16	20							18	8					
20	25	10	10/11	80	9	60	40	22,5	10	50	25	11	22	11
25	30							27,5	12,5					

Ordering code (example):

Rectangular Retainer = 2662.
for Punch to ISO 8020 = 01.
 $d_2 = \varnothing 13$ mm = 13
Order No = 2662.01.13

Ordering code (example):

Rectangular Retainer = 2662.
for Punch to ISO 8020 = 02.
 $d_2 = \varnothing 20$ mm = 20
Order No = 2662.02.20

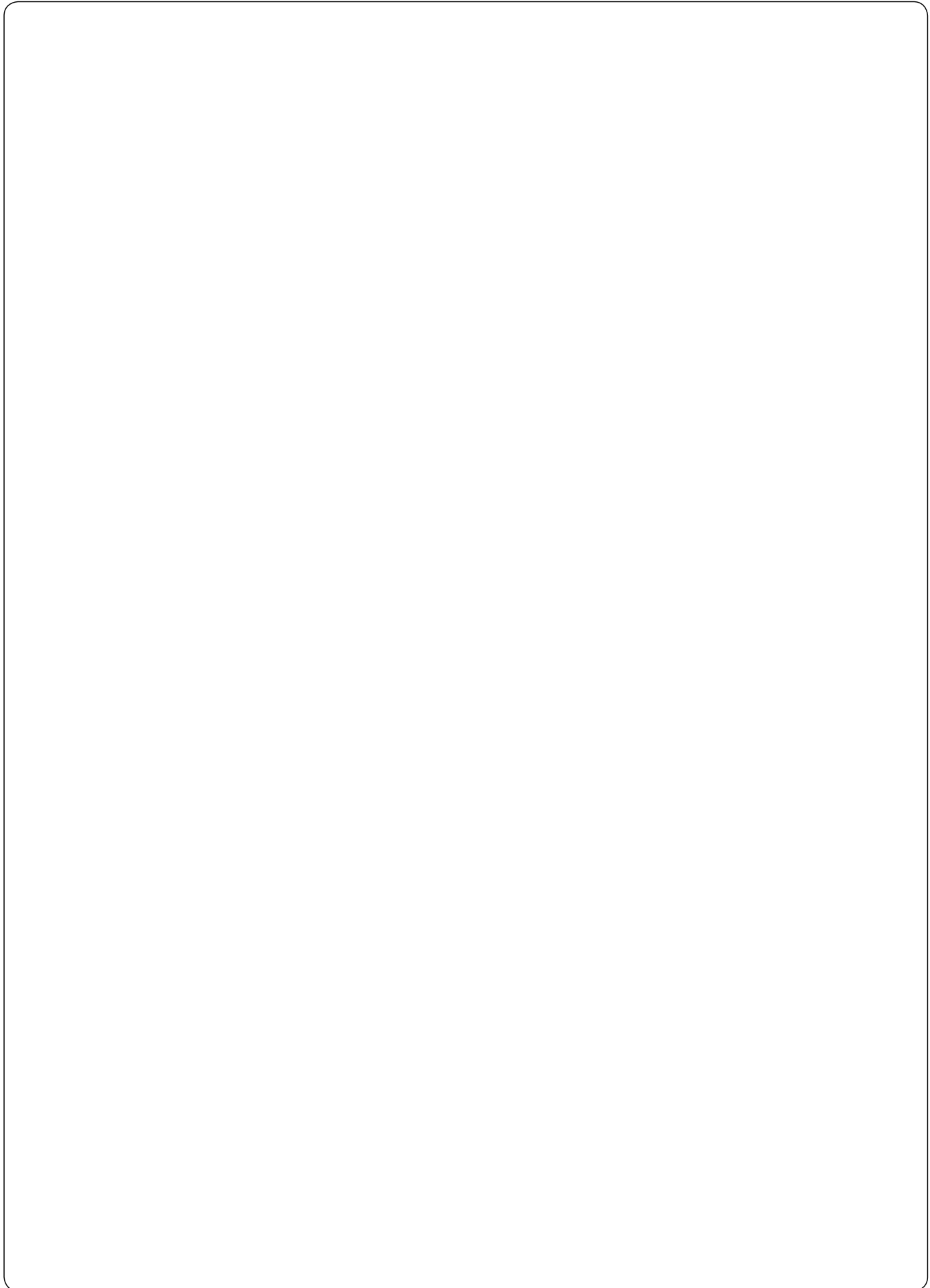

Precision Retainers VDI

**Square Precision Retainers
for round Punches to VDI 3374**

**2661.03.
2661.04.**

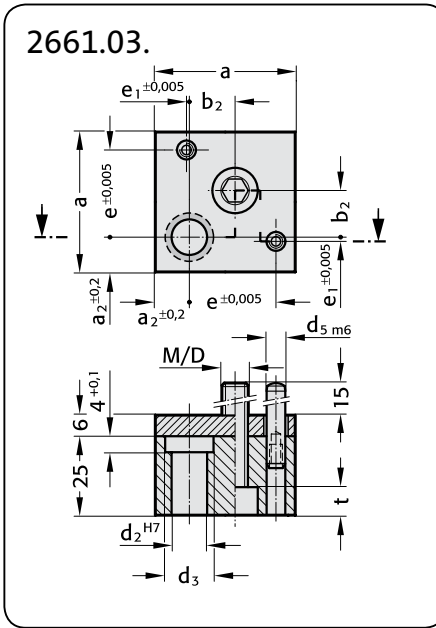

Execution:
The centres of the pinholes d_5 are the reference points for the position of the punch bore.
The e-dimensions have a tolerance of $\pm 0,005$ mm.
The square retainers are interchangeable.

Note:
Supplied with dowel pins and screws
DIN EN ISO 4762.

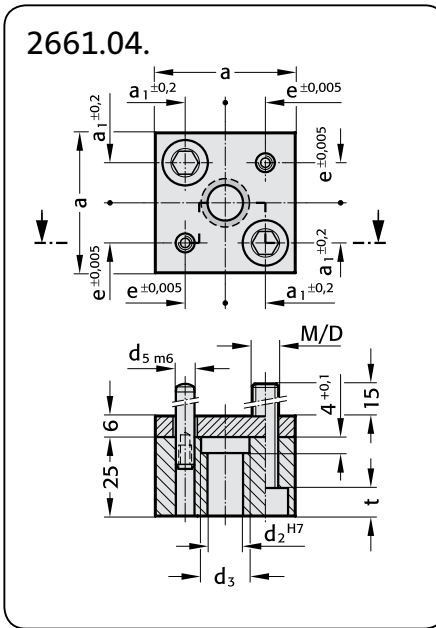
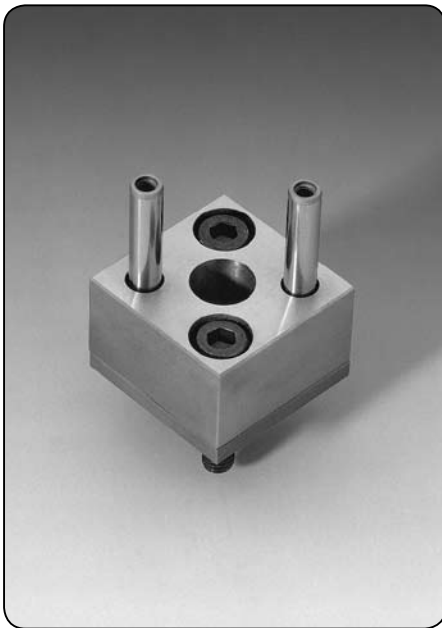

Execution:
The centres of the pinholes d_5 are the reference points for the position of the punch bore.
The e-dimensions have a tolerance of $\pm 0,005$ mm.
The square retainers are interchangeable.

Note:
Supplied with dowel pins and screws
DIN EN ISO 4762.

2661.03.

d_2	d_3	d_5	M/D	a	a_2	b_2	e	e_1	t
10	14	8	8/ 9	45	11	15	28	1	9
13	17								
16	20								
20	25	10	10/11	56	17	18	32	5	11
25	30								

Ordering code (example):
 Square retainer = 2661.
 for round Punch to VDI 3374 = 03.
 $d_2 = \varnothing 10$ mm = 10
 Order No = 2661.03.10

2661.04.

d_2	d_3	d_5	M/D	a	a_1, e	t
10	14	8	8/ 9	45	13	9
13	17					
16	20					
20	25	10	10/11	56	16	11
25	30		12/13,5	63	20	13
32	37					

Ordering code (example):
 Square retainer = 2661.
 for round Punch to VDI 3374 = 04.
 $d_2 = \varnothing 16$ mm = 16
 Order No = 2661.04.16

FIBRO

2661.05
2661.06.

Square Precision Retainers for Profile Punches to VDI 3374

Execution:

The centres of the pin holes d_5 are the reference points for the position of the punch bore.
The e-dimensions have a tolerance of $\pm 0,005$ mm.
The square retainers are interchangeable.

Note:

Supplied with dowel pins and screws
DIN EN ISO 4762.

2661.05.

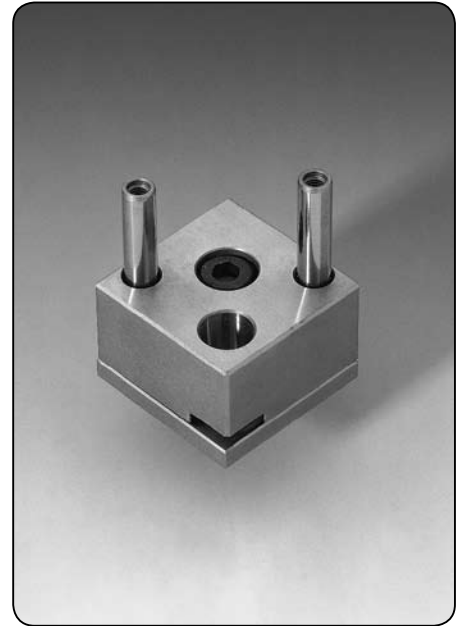
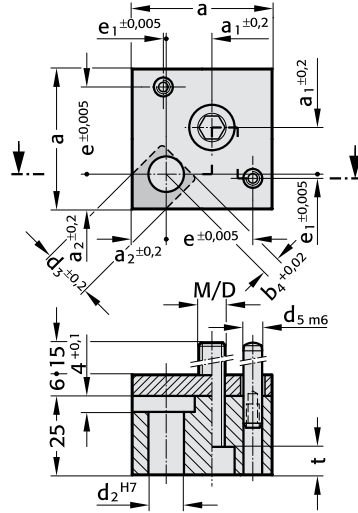

Execution:

The centres of the pin holes d_5 are the reference points for the position of the punch bore.
The e-dimensions have a tolerance of $\pm 0,005$ mm.
The square retainers are interchangeable.

Note:

Supplied with dowel pins and screws
DIN EN ISO 4762.

2661.06.

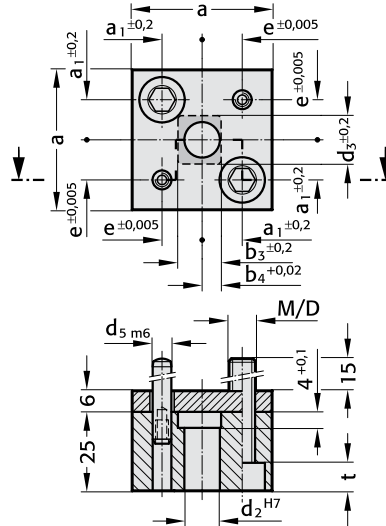

2661.05.

d_2	d_3	d_5	M/D	a	a_2	a_1	e	e_1	b_4	t
10	14	8	8/ 9	45	11	15	28	1	5	9
13	17								6,5	
16	20								8	
20	25	10	10/11	56	17	18	32	5	10	11
25	30								12,5	

2661.06.

d_2	d_3	d_5	M/D	a	a_1, e	b_3	b_4	t
10	14	8	8/ 9	45	13	12	5	9
13	17					15	6,5	
16	20					18	8	
20	25	10	10/11	56	16	22,5	10	11
25	30		12/13,5	63	20	27,5	12,5	

Ordering code (example):

Square retainer	= 2661.
for profile punch to VDI 3374	= 05.
$d_2 = \varnothing 13$ mm	= 13
Order No	= 2662.05.13

Ordering code (example):

Square retainer	= 2661.
for profile punch to VDI 3374	= 06.
$d_2 = \varnothing 20$ mm	= 20
Order No	= 2661.06.20

**Rectangular Precision Retainers
for Punches to VDI 3374**

**2662.03.
2662.04.**

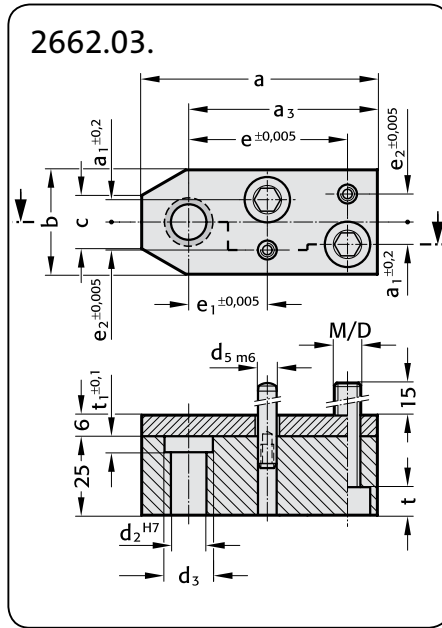

Execution:

The centres of the pin holes d_5 are the reference points for the position of the punch bore.
The e-dimensions have a tolerance of $\pm 0,005$ mm.
The rectangular retainers are interchangeable.

Note:

Supplied with dowel pins and screws
DIN EN ISO 4762.

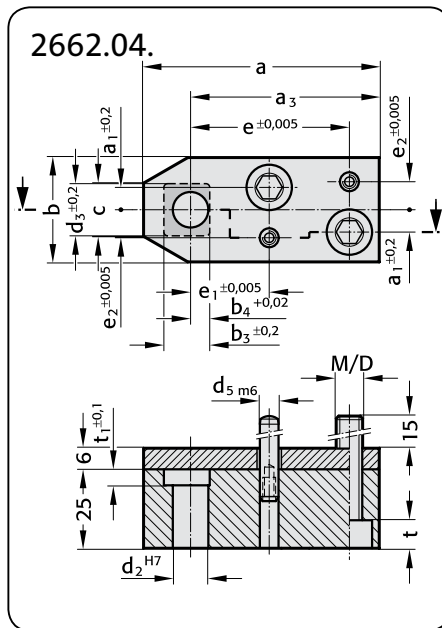

Execution:

The centres of the pin holes d_5 are the reference points for the position of the punch bore.
The e-dimensions have a tolerance of $\pm 0,005$ mm.
The rectangular retainers are interchangeable.

Note:

Supplied with dowel pins and screws
DIN EN ISO 4762.

2662.03.

d_2	d_3	d_5	M/D	a	a_1	a_3	b	e	e_1	e_2	c	t	t_1
6	10	8	8/9	75	7	60	32	50	25	9	16	9	3
10	14												4
13	17												
16	20												
20	25	10	10/11	85	9	63	40	53	28	11	20	11	
25	30												
32	37		12/13,5	95	13	70	50			15	30	13	

Ordering code (example):

Rectangular Retainer	= 2662.
for round punch to VDI 3374	= 03.
$d_2 = \varnothing 10$ mm	= 10
Order No	= 2662.03.10

2662.04.

d_2	d_3	d_5	M/D	a	a_1	a_3	b	b_3	b_4	e	e_1	e_2	c	t	t_1
6	10	8	8/9	75	7	60	32	8	3	50	25	9	16	9	3
10	14							12	5						4
13	17							15	6,5						
16	20							18	8						
20	25	10	10/11	85	9	63	40	22,5	10	53	28	11	20	11	
25	30							27,5	12,5						

Ordering code (example):

Rectangular Retainer	= 2662.
for profile punch to VDI 3374	= 04.
$d_2 = \varnothing 16$ mm	= 16
Order No	= 2662.04.16

Accessories

Stripping units

2431.7.



2431.7.

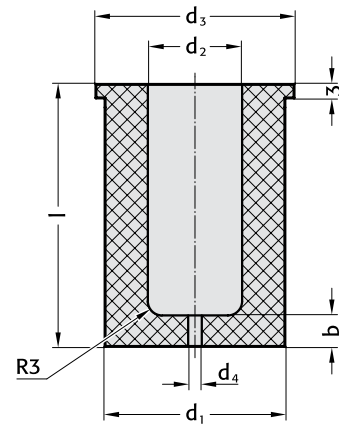

Material:

FIBROFLEX® 95 Shore A

Note:

Stripping units can be used for retainers 2664.02./04./05./06.

Installation example:

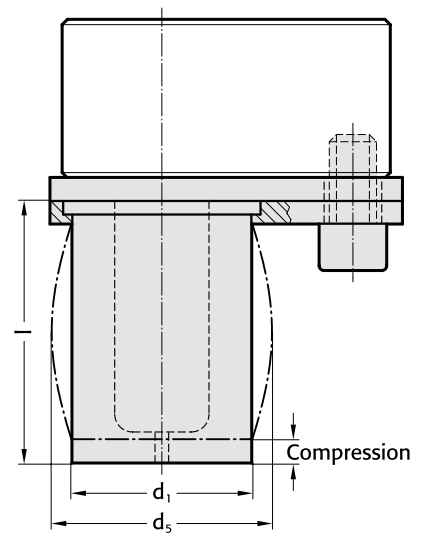

d ₂	Stripping unit length l				
	35	43	53	63	73
10	●	●	●	●	
13	●	●	●	●	●
16	●	●	●	●	●
20	●	●	●	●	●
25	●	●	●	●	●
32	●	●	●	●	●
38		●	●	●	●
40		●	●	●	●
Punch lengths in use					
Ball-lock punch, light duty	63	71	80	090	100
Ball-lock punch, heavy duty	71	80	90	100	110
Precision punch ISO 8020	—	71	80	090	100

2431.7.

d ₂	d ₁	d ₃	d ₄	d _{5 max.}	b	35	43	53	63	73
10	18	21	3	22	6	●	●	●	●	
13	23	26	3	26,5	6	●	●	●	●	●
16	30	33	3	34	6	●	●	●	●	●
20	33	36	3	38	7	●	●	●	●	●
25	40	43	3	47,6	7	●	●	●	●	●
32	50	54	4	57,9	7	●	●	●	●	●
38	60	64	4	69,6	8		●	●	●	●
40	60	64	4	69,6	8		●	●	●	●

Ordering example:

Stripping unit = 2431.7.
 d₂ = 10 mm = 10.
 l = 53 mm = 53
 Order number = 2431.7.10.53

* values for the stripping force are dependent on a number of parameters (e.g. lubricant, temperature etc.) and may vary from those given here.

** max spring travel should not exceed 15% of the length

d ₂	Stripping forces (N)*																	
	Spring travel	3mm			6mm			9mm			3mm			6mm			9mm	
Length	35	35	35	43	43	43	53	53	53	63	63	63	73	73	73	73	73	73
10	1300	**	**	1000	1700	**	900	1400	**	700	1200	1600	—	—	—	—	—	—
13	2100	**	**	1700	2700	**	1400	2200	**	1200	1900	2400	1000	1600	2000	—	—	—
16	3000	**	**	2500	4000	**	2000	3200	**	1700	2700	3500	1500	2400	3000	—	—	—
20	3500	**	**	2900	4700	**	2400	3800	**	2000	3200	4100	1700	2700	3600	—	—	—
25	5400	**	**	4400	7100	**	3600	5800	**	3000	4900	6300	2600	4200	5500	—	—	—
32	8400	**	**	6800	10900	**	5500	8800	**	4700	7500	9700	4000	6400	8400	—	—	—
38	—	—	—	—	—	**	7000	10400	**	6100	9200	12300	5000	7600	10100	—	—	—
40	—	—	—	10400	16600	**	8500	13600	**	7000	11300	14800	6000	9800	127000	—	—	—

2667.1.

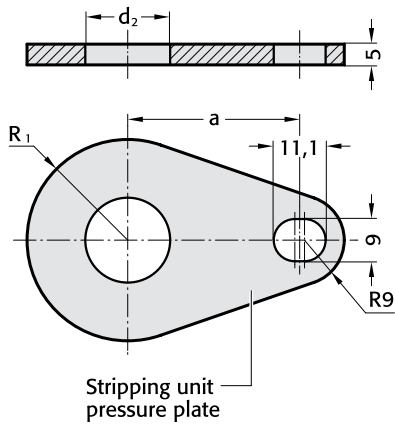

2667.2.

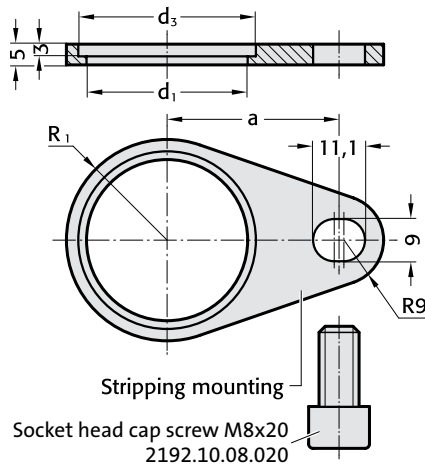

Installation example:

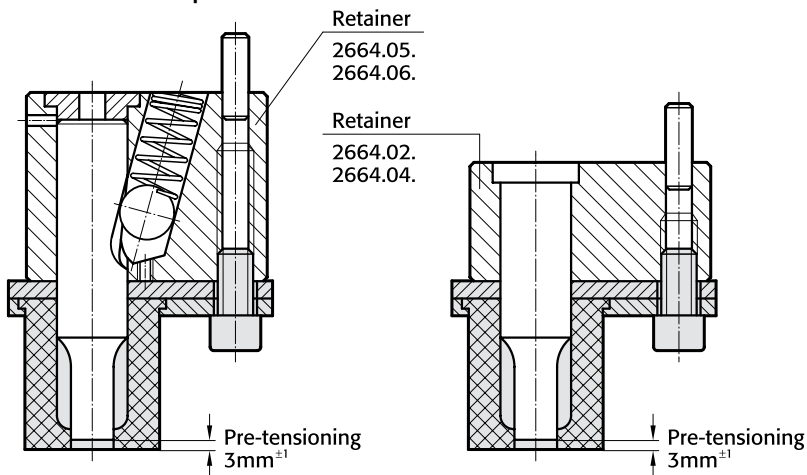

Mounting on retainer for ball-lock punch, multi-sided

Mounting on precision retainer, multi-sided ISO 8020

Note:

Pressure plate, mounting plate and screw must all be ordered individually.

2667.1/2.

d ₂	d ₁	d ₃	R ₁	a
10	18	21	13	28
13	23	26	15,5	31
16	30	33	18	32,9
20	33	36	20,5	34,8
25	40	43	24	39,8
32	50	54	31	41,3
38	60	64	36	44
40	60	64	36	44

Ordering example:

Stripping unit mountings = 2667.

Type = 1.

d₂ = 10mm = 010

Order number = 2667.1.010

Special Punches, Custom made
High-Precision Special Parts to Customer's Drawings



FIBRO

FIBRO manufactures Special Form Punches and -Matrices on most modern equipment. Projection Form Grinding, Creep Feed Grinding, EDM and Wire-EDM are used acc. to design details.

Many years of experience enable FIBRO to chose best suitable materials and methods. We manufacture to customer's drawings:

- Piercing Punches
- Draw Punched

- Form Punches
- Pre-Extrusion Punches and Ejectors for Bolt Manufacturing
- Flow-Forming Punches
- Punches with 30°-Conical Heads or other head shapes

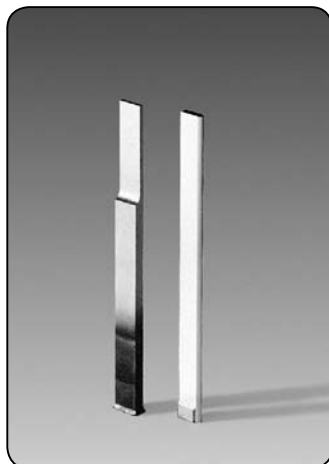
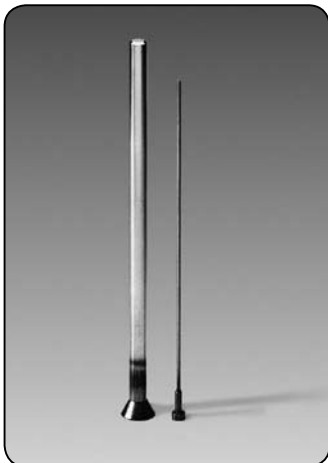

**Precision Punches, Square/Rectangular
without/with Hot Upset-Forged Head**

**230.
231.**

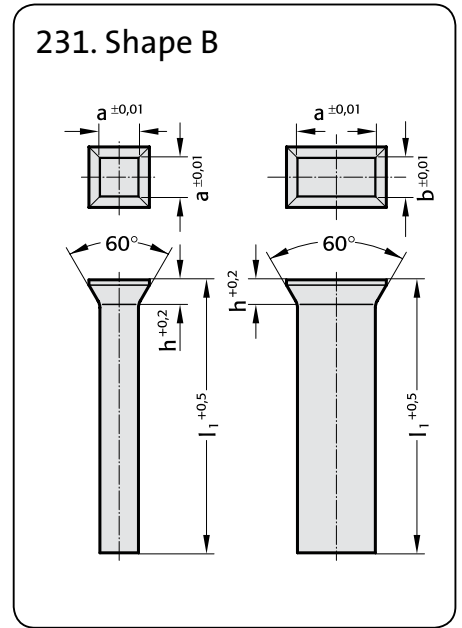
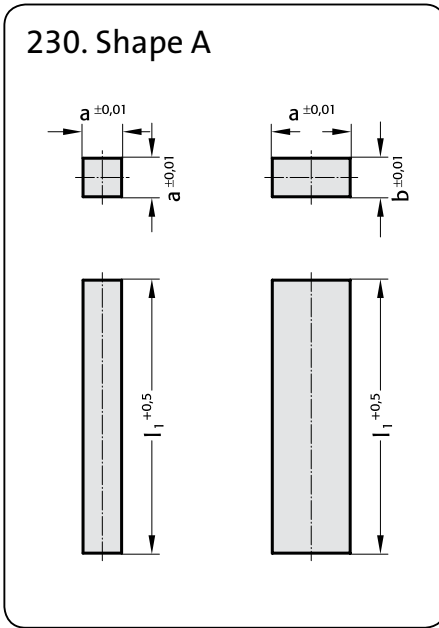

Material:
 HSS
 Order No: Shape A = 230.3, Shape B = 231.3.
 Hardness: Shank 64±2 HRC
 Head 52±3 HRC

Description of FIBRO materials for die components:
 pages E 10 and E 11.

Execution:
 Punch shanks precision ground.
 Heads hot upset forged – ground on special request.

230.

a	b	l ₁
1- 8	1	stock length of square punches: 73,5 mm; other materials and dimensions on request.
2-10	2	
3-12	3	
4-12	4	
5-15	5	
6-20	6	
7-24	7	
8-24	8	
9-28	9	
10-34	10	
12-34	12	

231.

a	b	h	l ₁
1- 8	1	1,2	stock length of square punches: 71 mm other materials and dimensions on request.
2-10	2	1,4	
3-12	3	1,8	
4-12	4		
5-15	5		
6-20	6	2,0	
7-24	7	2,8	
8-24	8		
9-28	9		
10-34	10		
12-34	12		

Ordering Code (example):

Punch = 231.
 Material HSS = 3.
 a = 10 mm = 1000.
 b = 6 mm = 0600.
 l₁ = 71 mm = 071
 Order No = 231.3.1000.0600.071

FIBRO

236.1.
236.001

Precision Dowel Pins (Parallel) with Internal Extracting Thread similar to DIN EN ISO 8735/ISO 8735 Dowel Pin Extractor "FIBROZIPP"

236.1.

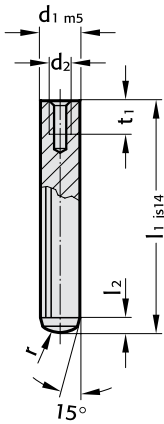

Material:

steel hardened

Order No: 236.1.

Hardness: 60±2 HRC

Execution:

Hardened and ground to finest finish. FIBRO Dowel Pins are manufactured with the exacting requirements of high class diemaking in mind. Whereas DIN EN ISO 8735 stipulates ISO Class 6 for dowels, we produce our pins to m5.

FIBRO Dowels with internal extracting thread deviate from DIN in that they are case-hardened and that a smaller thread is used. This increases the crosssection around the threaded hole and thus prevents breaking.

Ordering Code (example):

Dowel Pin with Extracting Thread = 236.1.

$d_1 = \varnothing 12 \text{ mm}$ = 1200.

$l_1 = 100 \text{ mm}$ = 100

Order No = 236.1.1200.100

236.1.

d_1	6	8	10	12	14	16	20	25
d_2	M 4	M 5	M 6	M 6	M 8	M 8	M 10	M 16
t_1	6	8	10	10	12	12	16	24
l_2	2,1	2,6	3	3,8	4	4,7	6	6
r	6	8	10	12	14	16	20	25
l_1								
16	●							
18	●							
20	●	●						
24	●	●	●					
28	●	●	●	●				
32	●	●	●	●	●			
36	●	●	●	●	●	●		
40	●	●	●	●	●	●	●	
45	●	●	●	●	●	●	●	●
50	●	●	●	●	●	●	●	●
55	●	●	●	●	●	●	●	●
60	●	●	●	●	●	●	●	●
70		●	●	●	●	●	●	●
80		●	●	●	●	●	●	●
90		●	●	●	●	●	●	●
100		●	●	●	●	●	●	●
120			●	●	●	●	●	●

236.001

FIBROZIPP

Extraction tool for the fast and convenient removal of dowels with internal extracting thread – also for shafts, plugs and other machine components.

The tool comes with interchangeable adaptors and screws, to fit all threads from M3 to M16.

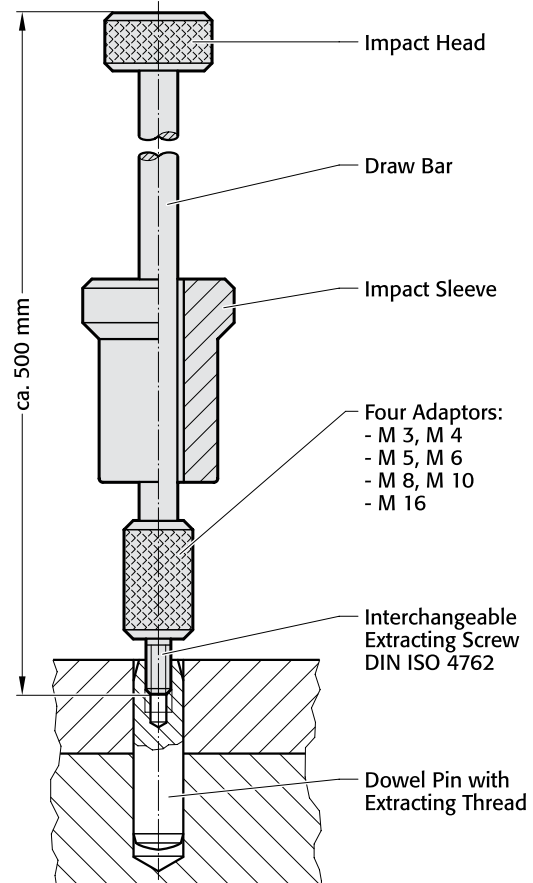

Precision Dowel Pins (Parallel) with Internal Extracting Thread
similar to DIN EN ISO 8735/ISO 8735
Dowel Pin Extractor "FIBROZIPP"

FIBRO
2361.1.
236.001

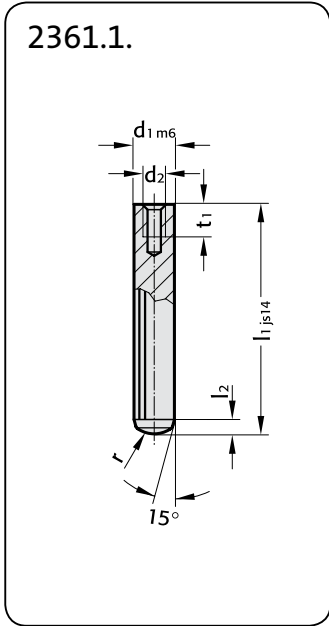

236.001 FIBROZIPP

Extraction tool for the fast and convenient removal of dowels with internal extracting thread – also for shafts, plugs and other machine components.

The tool comes with interchangeable adaptors and screws, to fit all threads from M3 to M16.

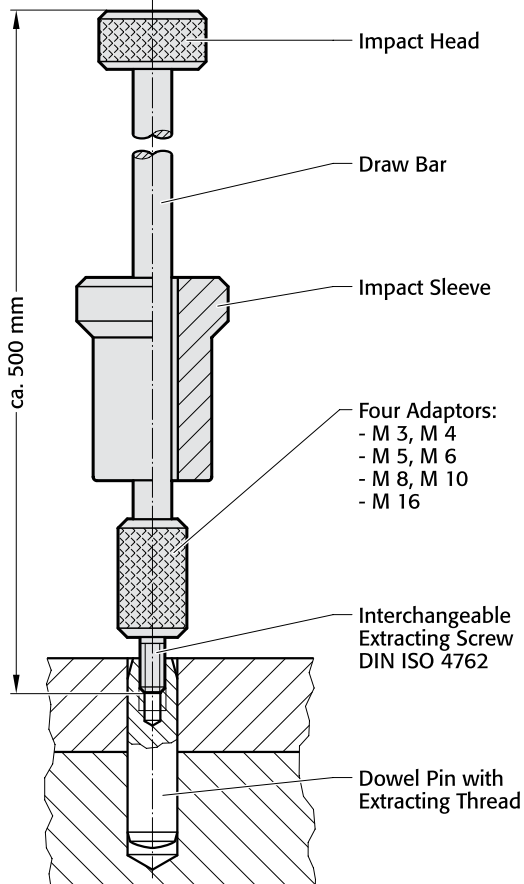

Ordering Code (example):

Dowel Pin = 2361.1.
 $d_1 = \varnothing 10 \text{ mm}$ = 1000.
 $l_1 = 45 \text{ mm}$ = 045
 Order No = 2361.1.1000.045

Material:

steel hardened

Order No: 2361.1.

Hardness: $60 \pm 2 \text{ HRC}$

Execution:

Hardened and ground to finest finish. FIBRO Dowel Pins are manufactured with the exacting requirements of high class diemaking in mind.

2361.1.

d_1	4	5	6	8	10	12	14	16	20
d_2	M 3	M 3	M 4	M 5	M 6	M 6	M 8	M 8	M 10
t_1	4,5	6	6	8	10	10	12	12	16
l_2	1,3	1,7	2,1	2,6	3	3,8	4	4,7	6
r	4	5	6	8	10	12	14	16	20
l_1									
8		●							
10	●	●							
12	●	●	●						
14	●	●	●						
16	●	●	●	●	●				
18	●	●	●	●	●				
20	●	●	●	●	●	●			
22			●	●					
24	●	●	●	●	●	●			
26			●	●					
28	●	●	●	●	●	●	●		
30	●	●	●	●	●	●			
32	●	●	●	●	●	●	●	●	
36	●	●	●	●	●	●	●	●	●
40	●	●	●	●	●	●	●	●	●
45		●	●	●	●	●	●	●	●
50	●	●	●	●	●	●	●	●	●
55		●	●	●	●	●	●	●	●
60		●	●	●	●	●	●	●	●
70			●	●	●	●	●	●	●
80			●	●	●	●	●	●	●
90				●	●	●	●	●	●
100				●	●	●	●	●	●
120				●	●	●	●	●	●

FIBRO

265.1.
2650.1.

High-Precision Liner Bushes for Dowel Pins, for bonding for push fit

265.1.
for epoxy bonding

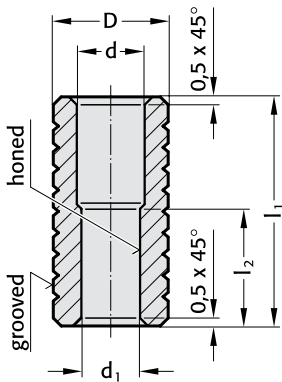

Material:
Tool Steel, hardened
Hardness 54±2 HRC

2650.1.
for push fit

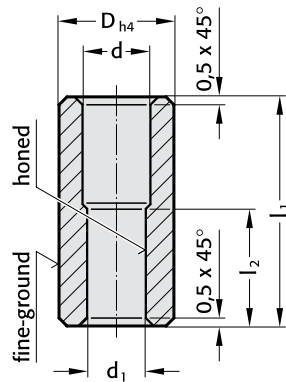

Material:
Tool Steel, hardened
Hardness 54±2 HRC

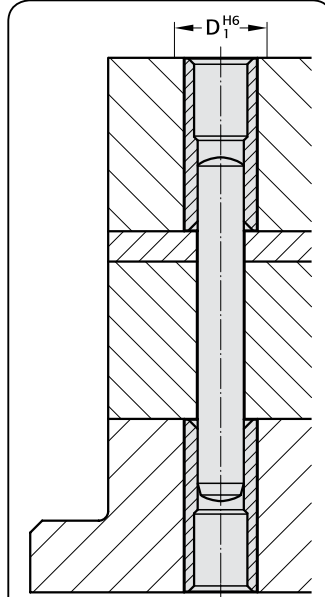
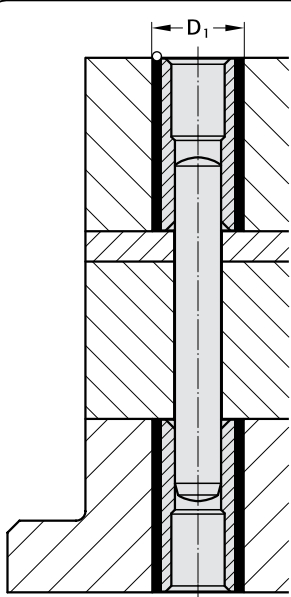
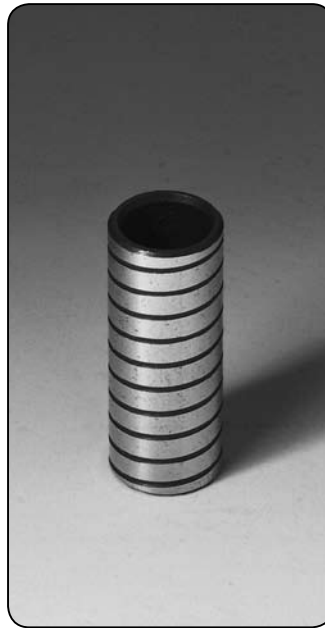

Epoxy-Bonding

FIBRO Hardened Dowel Liner Bushes solve the problem of wear on soft parts subjected to frequent dismantling. Held in perfect co-axial alignment by the close-fitting dowel, they are epoxy-bonded into rough-drilled clearance holes. In hardened parts, Dowel Liner Bushes help to overcome the ever-present toolroom problem of heat treatment distortion – insurmountable except where jig grinding facilities are available and justifiable on cost grounds. Retainer holes for Dowel Liner Bushes should be approximately 2 mm larger in diameter than the bush O.D. – a coarse finish is desirable. Following exact positioning/aligning, FIBROLIT® ZWO or FIBROFIX® SECHS is used for bonding.

Push Fit

The position of the bush is given by push fit hole tolerance $h6$. The adhesive order no. 281.648 provides optimum bush retention whilst offering the following advantages:

- high accuracy and stiffness
- no problems to find position when changing bushings.

We do not recommend to press fit bushings.

Ordering Code (example):

One Dowel Liner Bush – only –	
Dowel Liner Bush	= 265. analogous 2650.
Material: Tool Steel	= 1.
$d_1 = \varnothing 8,0$ mm	= 0800.
Quantity: one	= 1
Order No	= 265.1.0800.1

Ordering Code (example):

One Dowel Liner Bush + Matching Dowel	
Dowel Liner Bush	= 265. analogous 2650.
Material: Tool Steel	= 1.
$d_1 = \varnothing 8,0$ mm	= 0800.
Quantity: one	= 1.
Dowel: length= 40 mm	= 040
Order No	= 265.1.0800.1.040

Ordering Code (example):

Two Dowel Liner Bushes + one Dowel	
Dowel Liner Bush	= 265. analogous 2650.
Material: Tool Steel	= 1.
$d_1 = \varnothing 8,0$ mm	= 0800.
Quantity: two	= 2.
Dowel: length= 50 mm	= 050
Order No	= 265.1.0800.2.050

265.1.

d_1	d	D	D_1	l_1	l_2
6	7	10	12	25	12
8	9	12	14	30	16
10	11	16	18	36	20

2650.1.

d_1	d	D	D_1^{H6}	l_1	l_2
6	7	10	10	25	12
8	9	12	12	30	16
10	11	16	16	36	20

Precision Dowel Pins (Parallel)
similar to DIN EN ISO 8734/ISO 8734

235.1.



235.1.

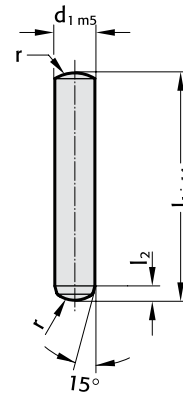

Execution:

Hardened and ground to finest finish.
FIBRO-Dowel Pins are manufactured with the exacting requirements of high class diemaking in mind. Whereas DIN EN ISO 8734 stipulates ISO Class 6 for dowels, we produce our pins to m5.

Material:

Order No: 235.1.
Hardness: 60±2 HRC
steel hardened

Ordering Code (example):

Dowel Pin	=	235.1.
$d_1 = \varnothing 10 \text{ mm}$	=	1000.
$l_1 = 80 \text{ mm}$	=	080
Order No	=	235.1.1000.080

235.1.

d_1	1	1,5	2	2,5	3	4	5	6	8	10	12	14	16	20
l_2	0,48	0,62	0,78	0,95	1,1	1,4	1,7	2,1	2,6	3	3,8	3,8	4,7	6
r	1	1,6	2	2,5	3	4	5	6	8	10	12	16	16	20
l_1														
6		●	●	●	●	●								
8	●	●	●	●	●	●	●							
10	●	●	●	●	●	●	●	●	●					
12	●	●	●	●	●	●	●	●	●	●				
14		●	●	●	●	●	●	●	●	●				
16		●	●	●	●	●	●	●	●	●	●			
18			●	●	●	●	●	●	●	●	●			
20			●	●	●	●	●	●	●	●	●	●		
24			●	●	●	●	●	●	●	●	●	●		
28			●	●	●	●	●	●	●	●	●	●		
32			●	●	●	●	●	●	●	●	●	●		
36		●	●	●	●	●	●	●	●	●	●	●	●	
40				●	●	●	●	●	●	●	●	●	●	●
45					●	●	●	●	●	●	●	●	●	●
50						●	●	●	●	●	●	●	●	●
55							●	●	●	●	●	●	●	●
60								●	●	●	●	●	●	●
70									●	●	●	●	●	●
80										●	●	●	●	●
90											●	●	●	●
100												●	●	●
120													●	●
130														●
140														

FIBRO

2351.1.

Precision Dowel Pins (Parallel) similar to DIN EN ISO 8734/ISO 8734

2351.1.

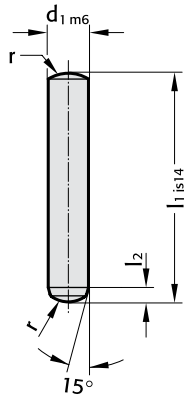

Material:

steel hardened

Order No: 2351.1.

Hardness: 60±2 HRC

Execution:

Hardened and ground to finest finish.

FIBRO-Dowel Pins are manufactured with the exacting requirements of high class diemaking in mind.

Ordering Code (example):

Dowel Pin = 2351.1.

∅ d₁ = 10 mm = 1000.

l₁ = 45 mm = 045

Order No = 2351.1.1000.045

2351.1.

d ₁	1	1,5	2	2,5	3	4	5	6	8	10	12	14	16	20	
l ₂	0,4	0,5	0,6	0,7	0,8	1	1,2	1,5	1,8	2	2,5	2,5	3	4	
r	1	1,6	2	2,5	3	4	5	6	8	10	12	16	16	20	
l ₁															
4	●	●	●												
5	●	●	●	●	●										
6	●	●	●	●	●	●									
8	●	●	●	●	●	●	●	●							
10	●	●	●	●	●	●	●	●	●						
12	●	●	●	●	●	●	●	●	●	●					
14		●	●	●	●	●	●	●	●	●					
16		●	●	●	●	●	●	●	●	●	●				
18			●	●	●	●	●	●	●	●	●				
20		●	●	●	●	●	●	●	●	●	●	●			
22		●	●	●	●	●	●	●	●	●	●	●	●		
24		●	●	●	●	●	●	●	●	●	●	●	●	●	
26			●	●	●	●	●	●	●	●	●	●	●		
28			●	●	●	●	●	●	●	●	●	●	●		
30			●	●	●	●	●	●	●	●	●	●	●		
32			●	●	●	●	●	●	●	●	●	●	●		
36				●	●	●	●	●	●	●	●	●	●	●	
40			●		●	●	●	●	●	●	●	●	●	●	
45					●	●	●	●	●	●	●	●	●	●	
50					●	●	●	●	●	●	●	●	●	●	
55						●	●	●	●	●	●	●	●	●	
60					●	●	●	●	●	●	●	●	●	●	
70						●	●	●	●	●	●	●	●	●	
80						●	●	●	●	●	●	●	●	●	
90							●	●	●	●	●	●	●	●	
100								●	●	●	●	●	●	●	
120									●	●	●	●	●	●	



FIBRO

276.
277.

Precision Drill Bushes Shape A DIN 172, with collar DIN 179, without collar

Material:

Special Steel, hardened
Hardness: 740±40 HV10

Execution:

Diameters d_1 and d_2 and shoulder precision ground.

Ordering Code (example):

Drill Bush	=	276.
Material: Special Steel	=	1.
$d_1 = 8,0$ mm	=	0800.
$l_1 = 20$ mm	=	020
Order No	=	276.1.0800.020

276. DIN 172 Shape A

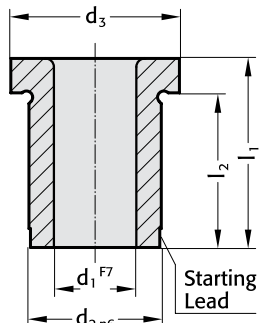

Material:

Special Steel, hardened
Hardness: 740±40 HV10

Execution:

Diameters d_1 and d_2 precision ground.

Ordering code (example):

Drill Bush	=	277.
Material: Special Steel	=	1.
$d_1 = 9,1$ mm	=	0910.
$l_1 = 25$ mm	=	025
Order No	=	277.1.0910.025

277. DIN 179 Shape A

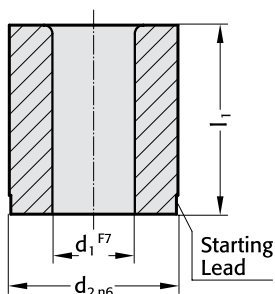

276.	d_1^*	d_2	d_3	short		medium		long	
				l_1	l_2	l_1	l_2	l_1	l_2
	0,4- 1,0	3	6	6	4	9	7	-	-
	1,1- 1,8	4	7	6	4	9	7	-	-
	1,9- 2,6	5	8	6	4	9	7	-	-
	2,7- 3,3	6	9	8	5,5	12	9,5	16	13,5
	3,4- 4,0	7	10	8	5,5	12	9,5	16	13,5
	4,1- 5,0	8	11	8	5,5	12	9,5	16	13,5
	5,1- 6,0	10	13	10	7	16	13	20	17
	6,1- 8,0	12	15	10	7	16	13	20	17
	8,1-10,0	15	18	12	9	20	17	25	22
	10,1-12,0	18	22	12	8	20	16	25	21
	12,1-15,0	22	26	16	12	28	24	36	32
	15,1-18,0	26	30	16	12	28	24	36	32
	18,1-22,0	30	34	20	15	36	31	45	40
	22,1-26,0	35	39	20	15	36	31	45	40
	26,1-30,0	42	46	25	20	45	40	56	51
	30,1-35,0	48	52	25	20	45	40	56	51
	35,1-42,0	55	59	30	25	56	51	67	62
	42,1-48,0	62	66	30	24	56	50	67	61
	48,1-55,0	70	74	30	24	56	50	67	61
	55,1-63,0	78	82	35	29	67	61	78	72

*diameter steps 0,1 mm

277.	d_1^*	d_2	short		medium		long	
			l_1	l_2	l_1	l_2	l_1	l_2
	0,4- 1,0	3	6	9	-	-	-	-
	1,1- 1,8	4	6	9	-	-	-	-
	1,9- 2,6	5	6	9	-	-	-	-
	2,7- 3,3	6	8	12	16	16	16	16
	3,4- 4,0	7	8	12	16	16	16	16
	4,1- 5,0	8	8	12	16	16	16	16
	5,1- 6,0	10	10	16	20	20	20	20
	6,1- 8,0	12	10	16	20	20	20	20
	8,1-10,0	15	12	20	25	25	25	25
	10,1-12,0	18	12	20	25	25	25	25
	12,1-15,0	22	16	28	36	36	36	36
	15,1-18,0	26	16	28	36	36	36	36
	18,1-22,0	30	20	36	45	45	45	45
	22,1-26,0	35	20	36	45	45	45	45
	26,1-30,0	42	25	45	56	56	56	56
	30,1-35,0	48	25	45	56	56	56	56
	35,1-42,0	55	30	56	67	67	67	67
	42,1-48,0	62	30	56	67	67	67	67
	48,1-55,0	70	30	56	67	67	67	67
	55,1-63,0	78	35	67	78	78	78	78

*diameter steps 0,1 mm

High-Precision Gauge Pins DIN 2269

240.

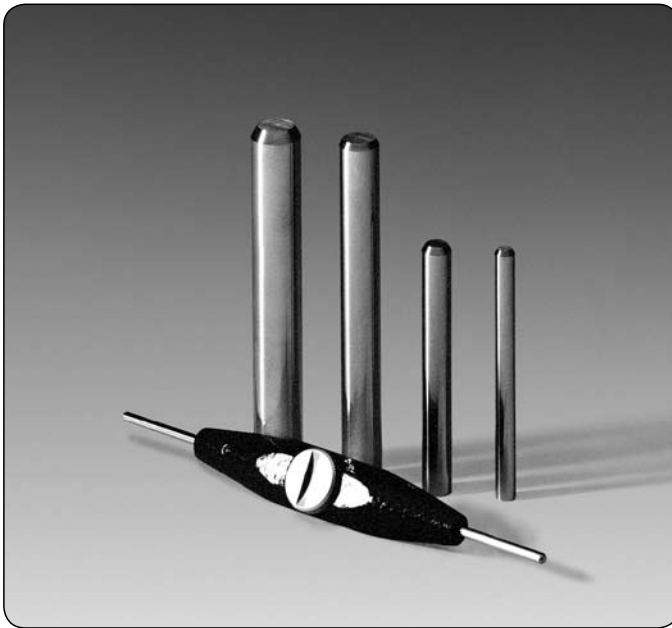

240.

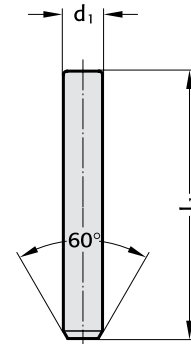

Material:

Alloy Tool Steel, hardened and tempered.
Age-treated repeatedly
Hardness: 60 ± 2HRC

Execution:

Precision ground
Class I – Accuracy: diameter tolerance ±0,001
Class II – Accuracy: diameter tolerance ±0,002

Direct gauging of bore diameters

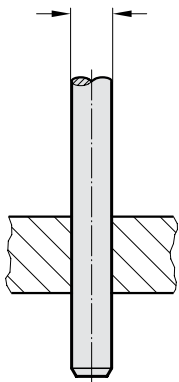

Measurement of centre-distance between two bores

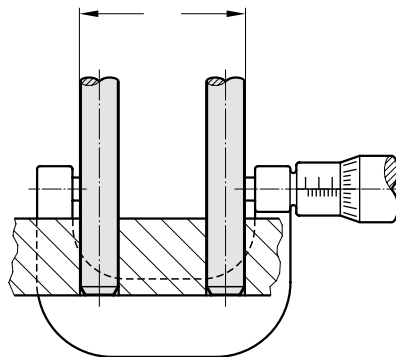

Concentricity check on a bush

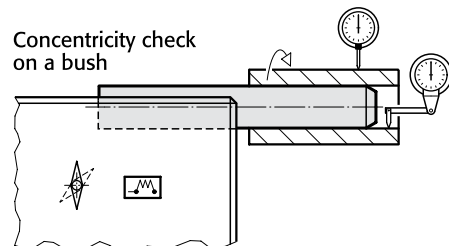

Measurements on prismatic faces

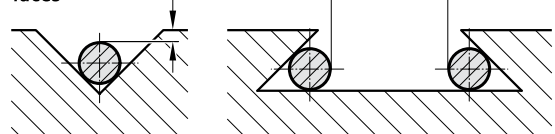

Single Pins:	Class I-Accuracy Class II-Accuracy	240.1. 240.2.
Small Set:	91 Gauge Pins from Ø 1-10 mm in steps of 0,1 mm, complete in wooden box Class I-Accuracy Class II-Accuracy	240.51. 240.52.
Large Set:	273 Gauge Pins from Ø 1-10 mm in steps of 0,1 mm, plus one each. 0,01 mm-oversize/undersize pin – complete in wooden box Class I-Accuracy Class II-Accuracy	240.41. 240.42.
Special Sets:	supplied to customer's requirements in respect of assortment and class of accuracy	
All Gauge Pins from 3 mm upward are marked with their actual size.		

240.

d_1	steps	l_1
0,30– 1,00	0,01	50
1,01– 3,00		
3,01– 6,00		
6,01– 10,00		70
10,01– 12,00		
12,01– 14,00		
14,01– 16,00		
16,01– 19,00		
19,01– 20,00		

Ordering Code (example):

Gauge Pin	= 240.
Class I-Accuracy	= 1.
$d_1 = \text{Ø } 4,04 \text{ mm}$	= 0404
Order No	= 240.1.0404

FIBRO

240.

High-Precision Gauge Pins DIN 2269 Gauge Pin Holders, Wooden Boxes



Calibration of a comparator

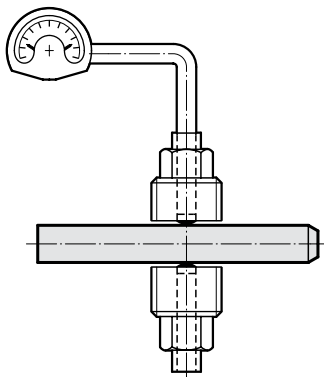

Inspection for squareness of a bore

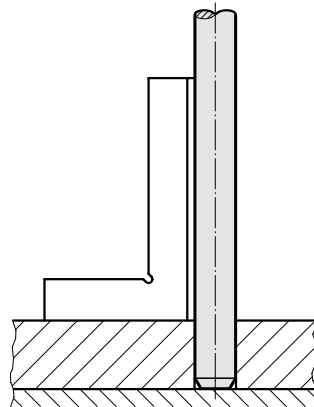

Check on parallelism

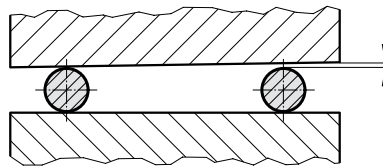

Measuring of gear teeth, threads etc.

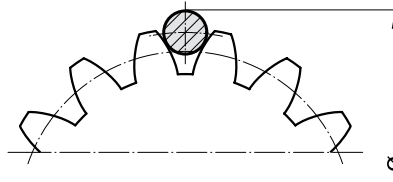

240.

Gauge Pin Holders
(with pins)

for diameters	Order No
from 1– 2	240.45.1
from 2– 4	240.45.2
from 4– 6	240.45.3
from 6– 8	240.45.4
from 8–10	240.45.5

Gauge Pin Holders are double-ended, to carry two pins e.g. for go – no go measurements etc.

Wooden boxes:
(without pins)

with drilled holes, for the safe and orderly storage of gauge pins – each hole marked with the requisite pin size.

Order No

Large Set of approx. 270 Pins
size: 390 x 250 x 90 mm

240.91.

Small Set of approx. 90 Pins
size: 285 x 155 x 90

240.92.

Boxes complete with carrier board inset
Class I-Accuracy
Class II-Accuracy

1
2

Ordering code (example):

Gauge pin box – approx. 270 pins	=	240.91.
Class I-Accuracy	=	1
Order No	=	240.91.1

**High Precision Gauge Pins with Handle
High Precision Gauge Pins – Boxed Sets**

240.11./22.
240.31./32.



240.11.

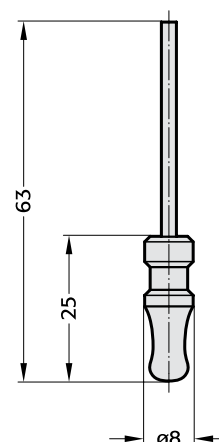

240.11. High-Precision Gauge Pins with Handle

The Gauge Pins are firmly fixed to the handle. Each Pin is marked with its true diameter.

Single Gauge Pins:	Ø 0,3 – 3,0 mm In dia. steps of 0.01 mm Class I -Accuracy Class II-Accuracy	Order No 240.11. 240.22.
--------------------	--	--------------------------------

Assortment: 84 Gauge Pins from 0.3 – 3.0 mm, in dia. steps of 0.1 mm plus one each pin with undersize 0.01 and oversize 0.01 mm (for example 0.29 – 0.30 – 0.31 etc.)
Class I -Accuracy 240.31.
Class II-Accuracy 240.32.

Special Assortments: to customer's specifications in respect of class of accuracy

Execution: Wooden boxes for Gauge Pins – with drilled holes in wooden tray insert. Each hole marked with true size of pin. External dimensions: 155x90x285 mm

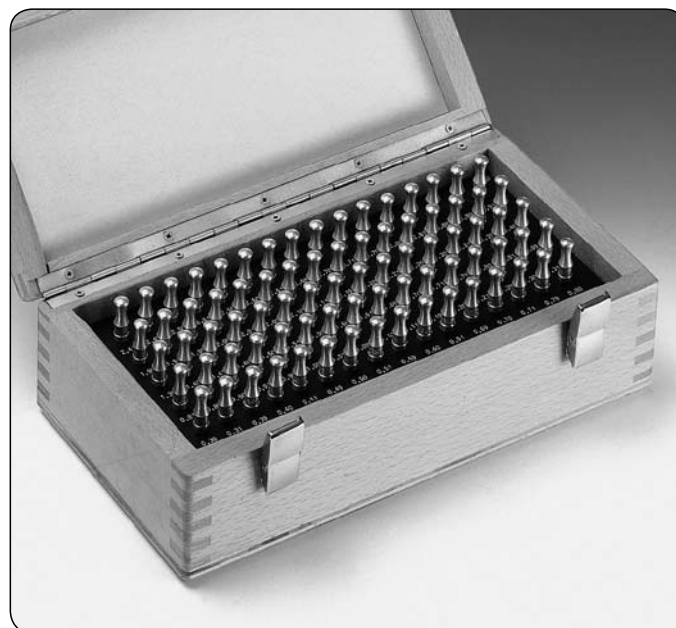

Material:

Alloy tool steel, hardened and tempered.
Repeatedly age-treated.
Hardness 60 ± 2 HRC.
fine-ground
Class I -Accuracy ±0.001
Class II-Accuracy ±0.002
to DIN 2269

Ordering Code (example):

Gauge Pin	= 240.
Class I-Accuracy, with handle	= 11.
d ₁ = 1,5 mm	= 0150
Order No	= 240.11.0150

FIBRO

2282.01.

Punching and Embossing Unit with Bottom Die for punched holes and self tapping screws

Material:

HSS

Execution:

The punching and embossing unit with bottom die consists of:

- 1 x punch die
- 1 x embossing die
- 1 x bottom die

Sheet metal thickness

- max. 0,6 mm = 2282.01.035
= 2282.01.039
- max. 0,8 mm = 2282.01.042
- max. 0,9 mm = 2282.01.048
- max. 1,0 mm = 2282.01.055
= 2282.01.063



2282.01.xxx

2282.01.xxx.1 Embossing die

2282.01.xxx.2 Punch die

2282.01.xxx.3 Bottom die

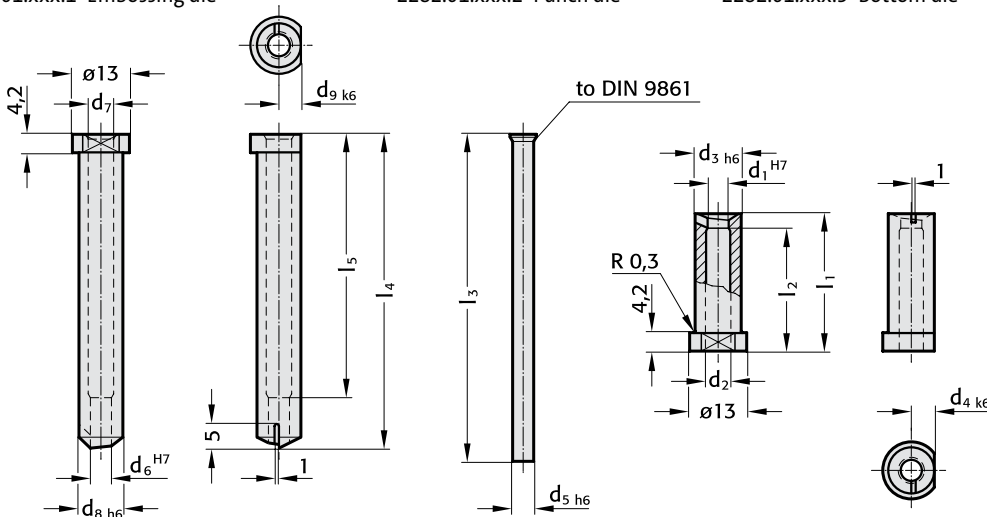

Example of application:

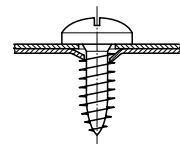

2282.01.

Order No	Nominal diameter = thread size	d ₁ ^{H7}	d ₂	d _{3h6}	d _{4k6}	d _{5h6}	d ₆ ^{H7}	d ₇	d _{8h6}	d _{9k6}	l ₁	l ₂	l ₃	l ₄	l ₅
2282.01.035	B 3,5	2,75	3,2	7,5	3,75	2,7	2,7	3,1	7,5	3,75	31,3	28	74,5	71,5	60
039	B 3,9	3,05	3,4	7,5	3,75	3,0	3,0	3,6	7,5	3,75					
042	B 4,2	3,15	3,5	8,5	4,25	3,1	3,1	3,7	8,0	4,0					
048	B 4,8	3,85	4,2	9,0	4,50	3,8	3,8	4,5	8,0	4,0					
055	B 5,5	4,35	4,8	9,0	4,50	4,3	4,3	5,0	8,0	4,0					
063	B 6,3	4,85	5,3	10,5	5,25	4,8	4,8	5,5	10,0	5,0					

Ordering Code (Example)

Punching and embossing unit with bottom die for punched holes = 2282.01.
 Nominal diameter = thread size (self tapping screw) = B = 3.5 mm = 035
 Order No = 2282.01.035

