

Linear and Motion Solutions

Linear guide systems

NEW
circular rails, lubricators,
FWN system



EP 2407 E

Linear guide systems



NADELLA

Summary

GU System

Sand blasted guide rails **GU..MT**

Ground guide rails **GU..M**

Guide Rollers **RKU**

Guide Wheels **FKU**

Lubricator **LUBU**

Guide pins **SAG**

NEW

ROLBLOC System

Sand blasted guide rails **GU..MT**

Ground guide rails **GU..M**

Guide Rollers **ROLBLOC**

FS System

Sand blasted guide rails **FS..MT**

Ground guide rails **FS..M**

Sand blasted guide rails **FSH..MT, FSX..MT**

Ground guide rails **FSH..M, FSX..M**

Sand blasted socket guide rails **FSB..MT**

Guide Rollers **FR..EI**

Guide Rollers **FRN..EI**

Guide Rollers **RKY, RKX**

Guide Wheels **FKY, FKX**

Floating Guide Rollers **FRL**

Floating Guide Rollers **FRLK..FRLR**

Lubricator **LUBY - LUBX**

NEW

FSR System

Circular rails **FSR..M**

NEW

	18	For medium-heavy loads	
	18		
	19		
	20		
	21		
	22		
	27		For medium-heavy loads Dirty environment
	27		
	34		For all applications
	35		
	36		
	37		
	38		
	39	For light-medium-loads	
	40	For light-medium loads with shocks	
	42	For medium-heavy loads	
	43	For medium-heavy loads	
	41	For light-medium loads	
	41		
	44-45		
	50	For light-medium loads	

Summary













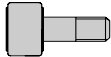











GP System	Guide rails GP..MC
	Ground guide rails GP..M
	Guide Rollers PK
	Guide Wheel FK
	Guide Rollers GC
	Lubricator LUBP
DC, C Systems	Guide rails DC
	Guide rails C
	Guide Rollers PFV
	Guide Rollers RKO
	Carriages T4PFV
	Wipers NAID
	Lubricator LUBC
FWS, FWH Systems	Guide rails FWS
	Guide rails FWH
	Guide Rollers FR..EI
	Guide Rollers FR
	Guide Rollers FR..-AS
	Guide Rollers FR..-AZ
	Carriages T4FR
	Sistems FWN
LM Systems	Guide rails LM
	Guide Rollers RCL, RCP, PFV
	Floating Guide Rollers RAL
	Guide Wheels GLA
	Carriages C3RCL, C3RCL, C3RYL
	Carriages C4RCL, C4RCL, C4RYL
	Carriages T4RCL, T4RCP, T4PFV, T4RAL, T4RYL
	Lubricator LUBM

NEW

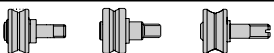
NEW

NEW

NEW

	54	For medium-heavy loads Dirty environment
	55	
	56	
	57	
	58	
	60	
	65	For medium loads Aggressive environment
	66	
	67-68	
	69	
	70	
	71	
	72	
	76	For light-medium loads
	77	
	78	
	79	
	80	
	81	
	82	
	85	For light-medium loads
	92	For light-medium loads
	93	
	94	
	95	
	96	
	96	
	97	
	97	

Nadella Linear System

With this line of products, NADELLA confirms the aim to provide manufacturing solutions tailored to the user's needs in order to achieve simple automation at a low cost.

The process under way of transferring production automation and relevant handling onto increasingly heavier and cumbersome units has prompted us to seek original and flexible components for the different commodity sectors.

We have accumulated sound working experience in the following sectors:

- marble-working machinery
- foundry machinery
- metal sheet working machinery
- special lifting machines
- pick up
- automatic warehouses
- textile machines
- machine tool protections and utilities
- oxygen cutting machines

Our Technical Department works with Customers and recommends the best component choice by making the calculations needed to determine the best life.

Guides

Length

The maximum length of each single guide component is shown on the dimensional tables.

The standard lengths of the rails are determined by adding the product of the fixing hole centre distance and the number of holes to twice the end dimension (see dimensional tables).

The following table provides the standard length tolerance.

Length	≥ 150 < 420	≥ 420 < 1.050	≥ 1.050 < 2.040	≥ 2.040 < 4.020	≥ 4.020 < 5.280
Length tolerance	±0,5	±0,8	±1,2	±2	±2,5

Joints

For strokes of greater length, the guide components can be joined after grinding the end faces (suffix R or RR). To maintain the hole centre distance tolerance, when ordering always specify the number of individual rails making one continuous length.

Please specify in the order when rails have to be matched.

Fixing holes

The guides are available with standard holes, as shown in dimensional tables, with special hole layout or without holes (see order code referencing)

Standard tolerance for hole position is $\pm 0,25$ mm

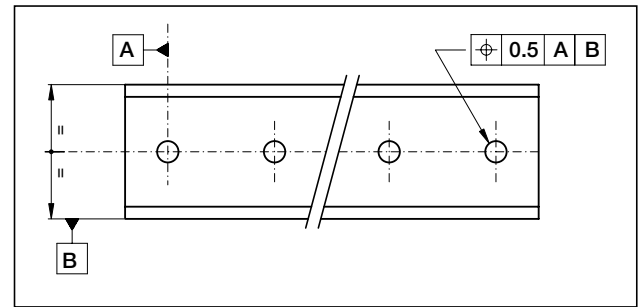

Steel guides

General

Steel rails are made of bearing steel to give best stability and durability. Raceways are induction hardened to achieve 58 HRC hardness minimum. The rail core remains soft to allow easy machining. Rails can be provided with different finishes to meet specific application requirements.

Guide rails MT type. Profile is produced by cold drawing process, raceways are induction hardened and sandblasted to improve surface strength and finish.

Guide rails M type. Profile is usually produced by cold drawing process, induction hardened on raceways and ground to improve surface finish and profile geometry and **to remove the partially decarburised surface** (0.1 mm max on cold drawn rails ..MT). Ground rails have to be used when there are high loads, heavy-duty cycles or when there is a high accuracy requirement.

Guide rails MC type (flat rail GP..MC only). MC rails are induction-hardened on every side and finish by-a-rough grinding.

Options

Corrosion protection

For use in oxidising environments or in the presence of corrosive agents, the guides are available with chemical nickel-plating protective anticorrosion treatment (suffix NW.).

This treatment features substantial mechanical characteristics together with a resistance to salty mist corrosion superior to that of hard chrome.

Circular rail

On request circular rails can be provided. Circular rails can be used as an alternative to rotating devices or as junction between straight rails.

Technical features

Standard rail straightness (for non-mounted rails) is 0.5 mm/m max. Higher accuracy can be supplied on request.

Temperature

Standard operating temperature range is -20°C up to 150°C . In lower or higher temperature applications please contact Nadella Technical Service. Special care is required if guide rollers are operating at maximum temperature.

Aluminium guides

General

Made by joining an aluminium alloy support element and hardened steel rods that form the sliding surfaces.

The best features of the two materials and relevant working technologies are combined to give the lightness of the alloy and the hardness and surface finish of the rods.

Guides of this type can be used for structural functions; they have a high moment of inertia that enables them to be used in many applications as carrying structures.

Aluminium extruded profiles are stabilised and anodised.

Sliding rods are induction hardened and ground.

Options

Corrosion protection

For use in oxidising environments or in the presence of corrosive agents, the guides of this series can feature stainless-steel bars (suffix NX).

Chromium-plated rods

Optional chromium-plated rods are available (suffix CH); the thickness of the chromium plating is $10 \pm 5 \mu\text{m}$ with hardness $\geq 800 \text{ HV}$.

Please check option availability in dimensional tables.

Joints

In case rail made by multiple C-DC or LM rails the most efficient joint can be realized with the insertion of a dowel pin inside the rods. This solution allows for simple assembly at the site and maintains alignment under load.

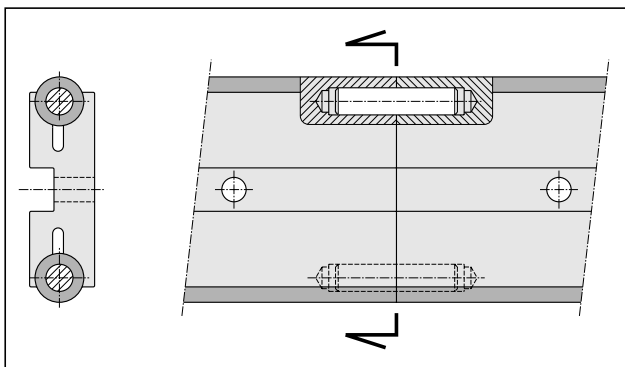

For rails FWS the joint can be realised by protruding the rods of one rail in order to engage them in the profile of the next rail. In the final configuration there will be a small gap between the aluminium profiles (see next drawing).

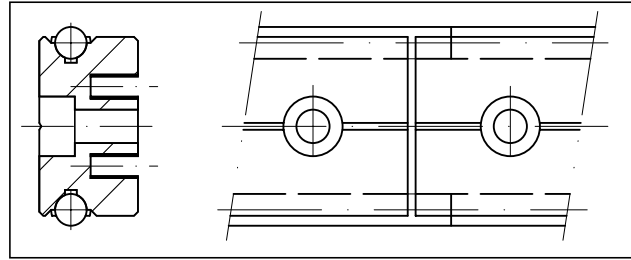

Technical features

Standard rails straightness (for non mounted rails) is 0.5 mm/m maximum. Higher accuracy can be supplied on request.

Temperature

Standard operating temperature range is -20°C up to 70°C . Applications with frequent temperature variation should be avoided. For operating conditions outside the given range please contact Nadella Technical Service

Guide rollers

General

Nadella provide a wide range of guide rollers to be able to meet different technical and economic requirements.

All guide rollers are produced in concentric and eccentric versions to allow backlash adjustment during assembly on final equipment. Eccentric rollers are identified by additional R in the code.

The sides of the races of the guide roller, except guide rollers FR,FR..AS,FR..AZ, are slightly convex. Besides reducing rolling friction, this also permits offsetting slight guide flexing or small assembly alignment errors.

Guide rollers are fitted with seals for bearing protection and lubricant retention as described in dimensional tables.

Guide rollers based on **needle or tapered roller bearings** (FRN..EI,RK..,PK..) are recommended for critical applications with heavy axial loads and/or shock loading. Guide rollers based on **ball bearings** (FR..FR..EI,RCL) are more suitable for lighter loads or high dynamic systems.

The carriages based on Rolbloc's system are recommended for applications with heavy loads, high frequency of work and aggressive environment (dust, abrasive).

When mounting guide rails opposite to each other with connected carriages, as shown in the sketch, a high level of parallelism between the guide rails is required when axially rigid rollers are used. To avoid operating problems it is recommended to use axial rigid fixed rollers on one carriage e.g.

FRN/FRNR...EI and axial movable rollers on the other carriage e.g. FRLK/FRLR. Movable rollers allow a little misalignment between the opposite mounted guide rails.

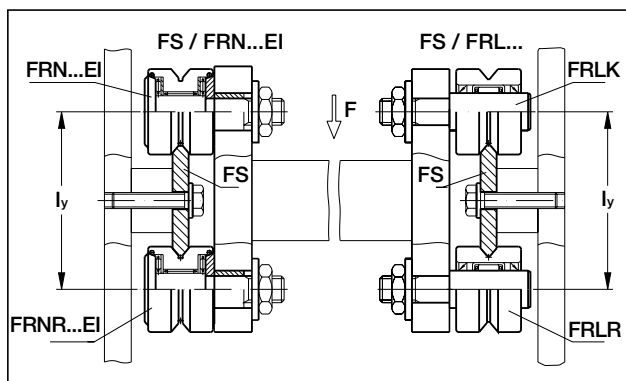

Another solution is to use one profiled guide rail e.g. FS and on the opposite side a flat rail e.g. GP in connection with rollers GC or PK.

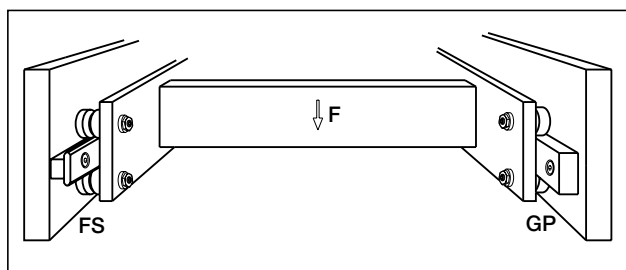

Technical features

Lubrication

Guide roller FRN..EI permits bearing relubrication. All other guide rollers are long life lubricated.

Temperature

Guide roller should not operate at constant temperature above 80°C. For short durations 100°C can be accepted. For higher temperature please see the “option section”.

Speed limit

Max velocity has to be determined for each application relevant to the guide roller type, size and load conditions. As general value, in normal conditions maximum speed is 4 m/sec. Contact Nadella Technical service in case of specific request.

Options

Corrosion protection

For uses in oxidising environments or in the presence of corrosive agents, the guide rollers are available in stainless steel (suffix NX). Check in the dimensional table component availability.

High temperature

On request guide rollers can be equipped with Viton seals to operate at temperature up to 120° (suffix V). Check in the dimensional table component availability.

Accessories

Tables and carriages

Standard table and carriages for C-DC and LM systems incorporate a black anodised aluminium plate fitted with guide rollers.

Wipers

Standard wipers NAID for C-DC rails are made from NBR compound moulded on a steel plate.

Lubricators

Are composed by two main parts: a plastic box with the same shape profile of the rail, and a lubricated felt; the felt is slightly pressed on the raceways by a spring. The plastic box, that drags the raceways, works as a wiper, and remove dust and shavings.

The plastic box can be mounted directly on the guide rollers plate by the appropriate aluminium plate included in the kit.

In the lubricators for guide rollers size 52 or higher, the grease nipple allows an easy connection with a re-lubrication system.

For the simply lubrication of the rails you can use one lubricator only on each raceway; in order to wipe the raceways it is better to mount two lubricators, before and after the carriage.

The lubricators are supplied with the felt already lubricated.

Lubrication

Bearing lubrication

All the guide rollers, except for the FRN..EI, based on needle bearings, are equipped with long life lubricated bearings. This means that the grease inside the bearings is enough for the entire life of the roller guide. The roller guide type FRN..EI, with needle bearings, allows the re-lubrication of the bearings.

Rail lubrication

Rails must be lubricated. This allows reducing the friction, to reach the calculated lifetime of the system and to work at high speed.

Not lubrication or sufficient lubrication is the cause of a rapid deterioration. The typical signal of the tribocorrosion is the developing of a red/dark oxides and rapid wearing of the rail and guide rollers.

The lubrication of the rail, the working environment and the load must be considered all together for a correct estimation of the lifetime of the guide system.

Generally speaking, for application with low frequency, can be sufficient a periodic relubrication with a grease or with a viscous oil. The re-lubrication interval depends on the application and must be always tested on the real working conditions.

In a system with ground rails and short stroke without lubricators, you can consider a re-lubrication interval every 100.000 cycles. You must reduce the interval with the increasing of the load and of the dimensions of the components, of the stroke and of the speed. For a constant lubrication we suggest to use lubricators with a felt, in order to have always a layer of lubricant between guide rollers and raceways.

The recommended lubricants are greases and oil for bearings, linear rails or chains, with a high viscosity of the basic oil and with EP additives, in order to separate the metallic surfaces even with low speed.

Assembly instructions

Guide rollers

The eccentric guide rollers allows the preload or clearance of the carriage to be adjusted independently of the guide roller mounting hole positioning tolerance or the distance between the rails.

Recommended mounting hole tolerance is H7.

When adjusting the eccentric guide roller care has to be taken to avoid excessive preload. Excessive preload can reduce the life of the linear system.

Set the preload turning the guide roller anticlockwise so that any movement caused by vibration will cause the nut to be tightened. Ensure the preload is not increased when tightening the nut.

A simple way of setting a roller preload is as follows:

1. move the slider on the guide, locking the roller being adjusted with two fingers to prevent it rotating
2. increase the preload by means of the wrench
3. repeat stage 1 making sure the roller slides without rolling
4. when it is no longer possible to prevent roller rolling, slightly decrease the preload action and fully tighten the lock nut, thereby setting the position of the eccentric.

When correctly adjusted it is just possible to cause the guide roller to slip on the guide rail when a torque is applied to the roller.

Guides

For single guide rail type FS, FWS, DC and LM no special assembly instructions are necessary. For multiple parallel rails parallelism has to be checked to avoid guide rollers overload or excessive carriage play. When constant preload is required parallelism error has to be lower than 0.050 mm.

Calculation procedure

Calculation is carried out in two steps, first defining the forces on the most heavily loaded roller and then estimating the safety factors and life.

Calculating the loads on the guide rollers

In the case of complex load situations, with forces acting in different directions, calculating the reactions on the rollers is difficult and hard to simplify.

In the event of the applied load having a direction parallel to one of the co-ordinate axes, the radial P_r and axial P_a components of the reactions on the most loaded roller can be obtained using elementary formulas.

With reference to the diagrams shown, we obtain the load components on the rollers relevant for checking and calculating the life, applying the following methods.

Angle α in the formulas is half the groove angle. Look in the dimensional table notes for the correct value.

Distance l_c is the effective contact distance. With the exception of ROLBLOC system the correct value is calculated as the guide rollers centre distance across the rail plus or minus the outer guide roller diameter, depending if the guide is outside or between the rollers.

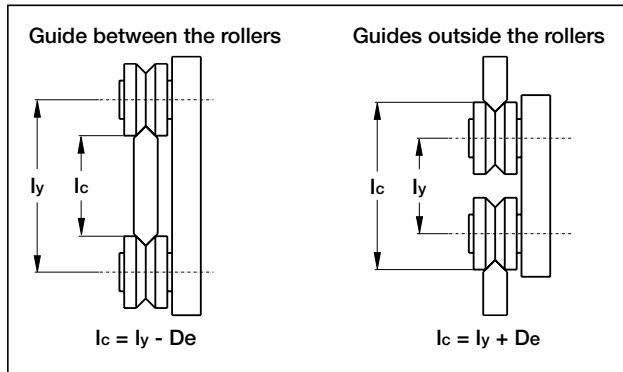

In case of ROLBLOC the distance l_c is the distance between the rails basis.

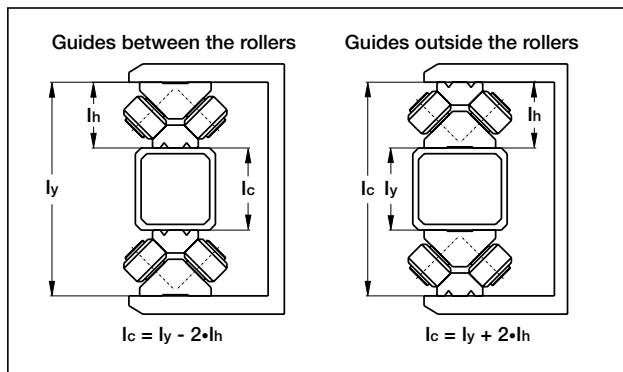
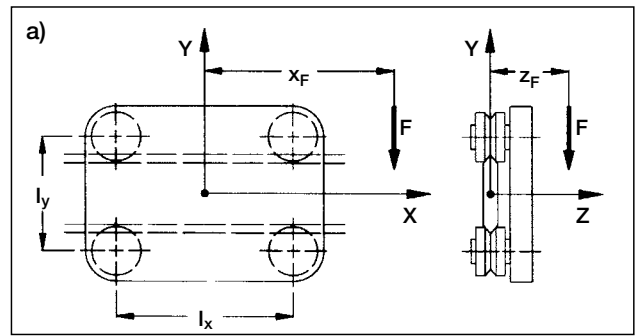

Diagram a) load F applied parallel to axis Y



$$P_a = \frac{F \cdot z_F}{2 \cdot l_c}$$

$$P_r = \frac{F \cdot (l_x + 2 \cdot x_F)}{2 \cdot l_x} + \frac{F \cdot z_F \cdot \tan \alpha}{2 \cdot l_c}$$

Diagram b) load F applied parallel to axis Z

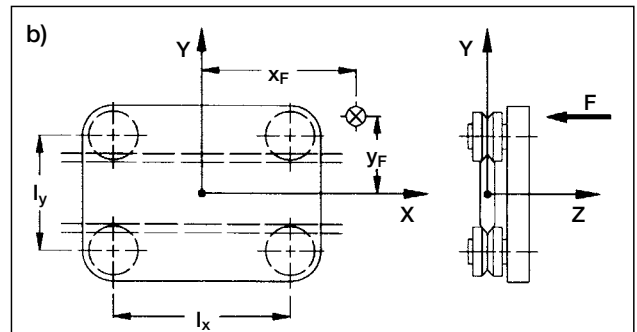

$$P_a = \frac{F}{4} + \frac{F \cdot x_F}{2 \cdot l_x} + \frac{F \cdot y_F}{2 \cdot l_c}$$

$$P_r = P_a \cdot \tan \alpha$$

Diagram c) load F applied parallel to axis X

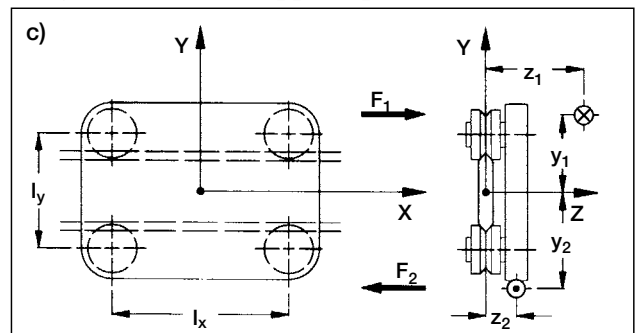

In this case the external load F_1 , applied at the point of co-ordinate $y_1 z_1$, should be considered together with reaction $F_2 = -F_1$, applied at the point of co-ordinate $y_2 z_2$. Calling Δy the absolute value of $y_2 - y_1$ and Δz the absolute value of $z_2 - z_1$, the following formula is used:

$$P_a = \frac{F_1 \cdot \Delta z}{2 \cdot l_x}$$

$$P_r = \frac{F_1}{l_x} \cdot \left(\frac{\Delta z \cdot \tan \alpha}{2} + \Delta y \right)$$

Guide roller calculation

In the table for each roller the following data is specified:

C_w basic dynamic load, it is the radial load [N] that applied to the guide roller gives 100 km nominal life*.

C_{or} bearing radial static load, it is the maximum radial load [N] that can be applied on the guide roller, limited by bearing contact stress.

C_{oa} bearing axial static load, it is the maximum axial load [N] that can be applied on the guide roller, limited by bearing contact stress.

F_r limit radial load, it is the maximum radial load [N] that can be applied on the guide roller due to the stud strength.

F_a limit axial load, it is the maximum axial load [N] that can be applied on the guide roller due to the stud strength.

X and Y coefficients to define the equivalent load for bearing life.

α is the contact angle dependent on the guide roller type.

Rollers FRN..EI work as combined bearings, the basic dynamic load is defined as:

C_{wr} basic radial dynamic load, it is the radial load [N] that applied to the guide roller gives 100 km nominal life*.

C_{wa} basic axial dynamic load, it is the axial load [N] that applied to the guide roller gives 100 km nominal life*.

Note1*: ISO 281 states ‘the nominal life will be exceeded by 90% of bearings before the first sign of material fatigue’.

Nominal life calculation

System life is the minimum life of either the bearings in the guide roller or the rail/roller contact surfaces.

For the rail/roller surface see the lubrication paragraph. For the bearings life proceed as follows.

The loads P_r and P_a are calculated for ideal condition. However, in practice, because of the structure and operating conditions a better calculation and life estimation is performed using overload factor f_w as follows:

- 1.0 – 1.2 smooth operation at low speed at constant load without shocks
- 1.2 – 1.5 smooth operation with load variation
- 1.5 – 2.0 operation with small shocks and vibrations
- 2.0 ~ 4.0 high acceleration, shocks and vibrations

Once P_a and P_r has been defined we can proceed to calculate the equivalent load P_{eq} (not for FRN..EI).

$$P_{eq} = X P_r + Y P_a \quad [N]$$

Coefficients X and Y can be obtained from guide rollers tables (in case of tapered bearings accordingly with ratio between P_a and P_r).

In case of pure radial guide roller as PK and GC or floating bearings FRL, RAL.

$$P_{eq} = P_r \quad [N]$$

Nominal bearing life:

$$L_{10} = 100 \left(\frac{C_w}{P_{eq} \cdot f_w} \right)^p \quad [km]$$

Where coefficient P is:

$P = 3$ for ball bearing guide rollers (FR,FR..EI, , RCL..., PFV..., RAL)

$P = 10/3$ for roller bearing guide rollers (PK...,RKY,RKX,ROLBLOC,GC,FRL..)

In case of guide rollers based on needle bearings type FRN..EI

nominal bearing life is calculated as the minimum between:

$$L_{10} = 100 \left(\frac{C_{wr}}{P_r \cdot f_w} \right)^{10/3} \quad [km]$$

and

$$L_{10} = 100 \left(\frac{C_{wa}}{P_a \cdot f_w} \right)^{10/3} \quad [km]$$

Checking the roller stud

The values of the radial limit loads F_r and axial limit loads F_a shown in the catalogue refer to extreme operating conditions, meaning:

$P_a = 0$ (pure radial load)

$P_r = P_a \tan \alpha$ (maximum axial load)

In intermediate cases, when the ratio is included between the extreme values, the equivalent limit load F_k to be considered must be calculated according to ratio $k = P_a/P_r$.

$$F_k = \frac{F_r \cdot F_a}{K \cdot F_r + (1 - K \tan \alpha) \cdot F_a} \quad [N]$$

To check the strength of the stud, in relation to the limit load, the safety factor has to be greater than 1

$$F_k/P_r > 1$$

Note: in the following common cases it is not necessary to calculate F_k and stud safety evaluation can be completed easily.

In case of floating bearings type FRL and guide rollers PK and GC there isn't any axial load. In case of loads acting in the guide roller plane (F_x or F_y)

acting with $Z=0$) the axial load is also zero (0) (see calculation example n° 3).

In these cases it has to be

$$\text{Safety stud check} \quad F_r/P_r > 1$$

In case of load F_z acting perpendicular at guide roller plane the axial load is maximum (load case c, example n° 4).

$$\text{Safety stud check} \quad F_a/P_a > 1$$

Checking the bearing max load

In case of guide rollers based on tapered roller bearings (PK..C, RKU.., RKY.., RKX..) or ball bearings (FR..EI RCL.. PFV..)

We proceed as for the stud

$$\text{ratio } k = P_a/P_r.$$

$$C_{ok} = \frac{C_{or} C_{oa}}{K C_{or} + (1 - K \tan \alpha) C_{oa}} \quad [\text{N}]$$

To check the bearing static safety factor it has to be:

$$C_{ok}/P_r > 1$$

As explained for stud calculation in case of pure radial load or max axial load, calculations can be made using values directly from the tables (see calculation example 3 and 4).

In case of guide rollers based on needle bearings type FRN..EI

To check the bearing static safety factor it has to be:

$$\begin{aligned} C_{or}/P_r &> 1 \\ C_{oa}/P_a &> 1 \end{aligned}$$

In case of guide rollers have two outer rings and ball bearings FR..,

To check the bearing static safety factor it has to be:

$$C_{or}/P_r > 1$$

$$C_{oa} / \left(\frac{P_a}{2} + \frac{P_r}{2 \tan \alpha} \right) > 1$$

Examples of calculation

1) A fork-lift truck featuring vertical movement (sketch 1).

The resulting magnitude of the weight passes through point 1, while the vertical force that balances this, for instance the traction of a timing belt, passes through point 2.

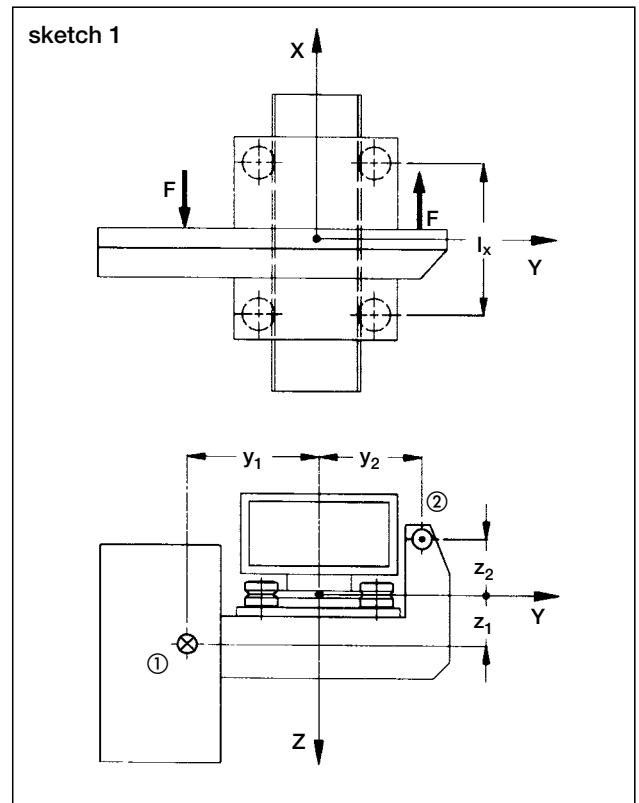

Guide rollers type RKY 52 are used with guide rail type FS 62 MT

overload factor $f_w = 1,0$

center distance $l_x = 300 \text{ mm}$ $l_y = 144,3$

$F = 2000 \text{ N}$ $z_1 = 100 \text{ mm}$ $y_1 = -150 \text{ mm}$

$z_2 = -250 \text{ mm}$ $y_2 = 350 \text{ mm}$

$\Delta_z = 350 \text{ mm}$ $\Delta_y = 500 \text{ mm}$

Load on rollers

$$P_a = \frac{2000 \cdot 350}{2 \cdot 300} = 1.167 \text{ N}$$

$$P_r = \frac{2000}{300} \cdot \left(\frac{350 \tan 40}{2} + 500 \right) = 4312 \text{ N}$$

Nominal life

$$k = P_a/P_r = 0.27 \rightarrow X = 0.77 \quad Y = 6.98$$

Equivalent dynamic load

$$P_{eq} = 0.77 \cdot 4312 + 6.98 \cdot 1167 = 11464 \text{ N}$$

$$L_{10} = 100 \left(\frac{40800}{11464 \cdot 1} \right)^{10/3} = 6880 \text{ km}$$

Stud safety coefficient

Equivalent limit load F_k

$$F_k = \frac{11900 \cdot 4250}{0.27 \cdot 11900 + (1 - 0.27 \tan 40) \cdot 4250} = 7780 \text{ N}$$

Stud safety coefficient

$$F_k/P_r = 7780 / 4312 = 1.8$$

Bearing safety coefficient

Equivalent limit load C_{ok}

$$C_{ok} = \frac{44000 \cdot 12400}{0.27 \cdot 44000 + (1 - 0.27 \tan 40) \cdot 12400} = 25380 \text{ N}$$

Bearing static safety coefficient

$$C_{ok}/P_r = 25380 / 4312 = 5,9$$

2) The horizontal axis of a manipulator in steel industry

The centre of gravity of the vertical axis and load is placed in the middle of the horizontal centre-axis l_x and 160 mm distance from the guide axis. The dirty environment and the possibility of shocks lead to the choice to ROLBLOC system.

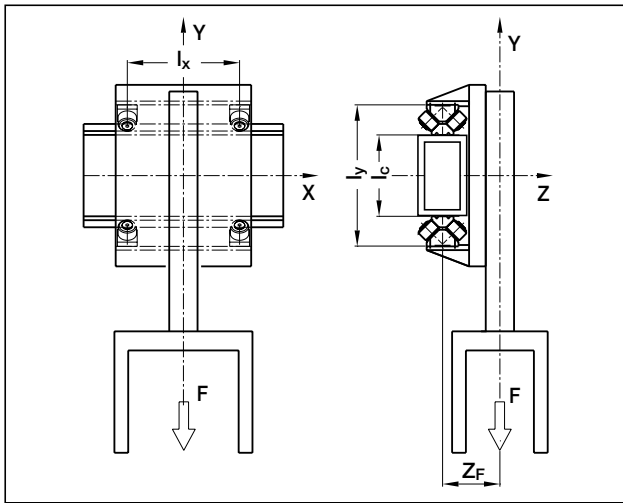

Guide rollers BL252 are used with guide GU62M
 Overload factor $f_w = 1,4$
 Centre distance $l_x = 350 \text{ mm}$ $l_y = 400 \text{ mm}$
 $F = 6000 \text{ N}$ $x = 0$ $y = -1000$ $z = 160 \text{ mm}$

Load on rollers

The effective centeraxis l_c is $400 - 85 - 85 = 230 \text{ mm}$

$$P_a = \frac{6000 \cdot 160}{2 \cdot 230} = 2087 \text{ N}$$

$$P_r = \frac{6000}{2} + \frac{6000 \cdot 160 \tan 45}{2 \cdot 230} = 5087 \text{ N}$$

Nominal life

From the ROLBLOC table $X=1, Y=1$

$$P_{eq} = 1 \cdot 2087 + 1 \cdot 5087 = 7174 \text{ N}$$

$$L_{10} = 100 \left(\frac{59000}{7174 \cdot 1.4} \right)^{10/3} = 36577 \text{ km}$$

Stud safety coefficient

$$K = P_a/P_r = 2087/5087 = 0,41$$

$$F_k = \frac{16800 \cdot 8400}{0.41 \cdot 16800 + (1 - 0.41 \tan 45) \cdot 8400} = 11915 \text{ N}$$

$$F_k/P_r = 11915 / 5087 = 2.3$$

Bearing safety coefficient

$$C_{ok} = \frac{62000 \cdot 31000}{0.41 \cdot 62000 + (1 - 0.41 \tan 45) \cdot 31000} = 43972 \text{ N}$$

$$F_k/P_r = 43972 / 5087 = 8.6$$

3) The sliding door of a machine tool (rail on top)

The door is supported by the rail DC type on the upper edge and driven on bottom side by an auto-aligning carriage C3RAL on LM guide rail type. Because of the effect of the bottom rail there isn't any torque applied at the DC rail. The door weight acts in a plane coincident with the roller/rail vertical axis and as such there is no over turning moment. In this case, limit load calculation can be easily carried out from basic data F_a and C_{oa} without F_k and C_{ok} calculation. Of course the calculation is always the same.

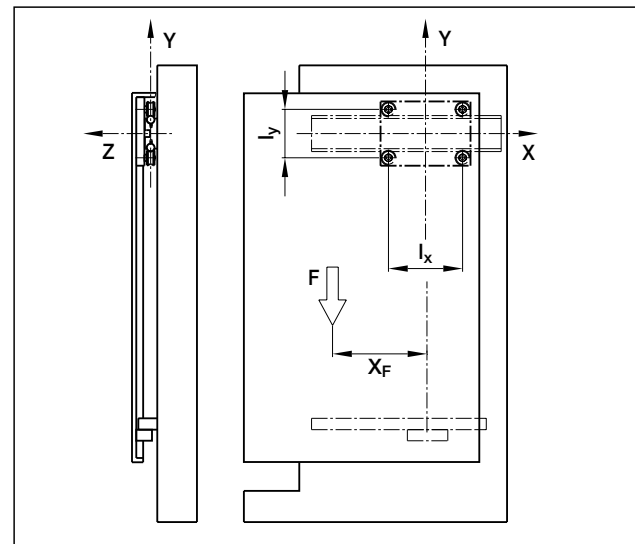

Guide rail DC18.65 is used with carriage
 T4 PFV 3518 250
 Overload factor $fw = 1,1$
 Centre distance $l_x = 213 \text{ mm}$ $l_y = 113 \text{ mm}$
 $F=450 \text{ N}$ $x=-300$ $y=-500$ $z = 0$
 (because of LM rail) mm

Load on rollers

The effective centeraxis l_c is $113 - 35 = 78 \text{ mm}$

$$P_a = \frac{450 \cdot 0}{2 \cdot 78} = 0 \text{ N}$$

$$P_r = \frac{450 \cdot (213 + 2 \cdot 300)}{2 \cdot 213} + \frac{450 \cdot 0 \cdot \tan(40)}{2 \cdot 213} = 859 \text{ N}$$

Nominal life

$$L_{10} = 100 \left(\frac{4570}{859 \cdot 1,1} \right)^3 = 11300 \text{ km}$$

Stud safety coefficient

$$F_r/P_r = 2120 / 859 = 2,4$$

Bearing safety coefficient

$$C_{or}/P_r = 2320 / 859 = 2,7$$

4) Transfer unit

The box weight loads the carriage with max axial load. In this load configuration the safety stud check calculation can be easily done directly by the F_a and Co_a value without F_k calculation.

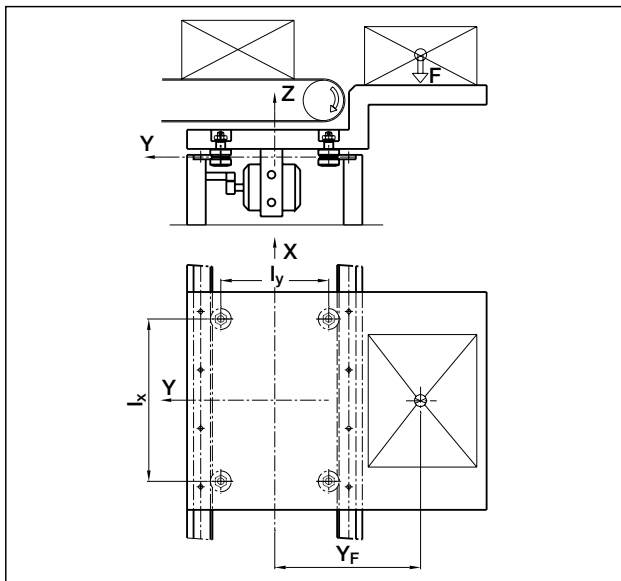

Guide rollers FRN(R)32EI with rails FSH32M
 Overload factor $fw = 1,2$
 Centre distance $l_x = 670 \text{ mm}$ $l_y = 450 \text{ mm}$
 $F=400 \text{ N}$ $x=0$ $y=650$ $z = 50 \text{ mm}$

Load on rollers

The effective centeraxis l_c is $450 + 32 = 482 \text{ mm}$

$$P_a = \frac{400}{4} + \frac{400 \cdot 650}{2 \cdot 482} = 370 \text{ N}$$

$$P_r = 370 \tan 40 = 310 \text{ N}$$

Nominal life

$$L_{10r} = 100 \left(\frac{5600}{310 \cdot 1,2} \right)^{10/3} = 840000 \text{ km}$$

$$L_{10a} = 100 \left(\frac{2100}{370 \cdot 1,2} \right)^{10/3} = 17760 \text{ km}$$

$$L_{10} = 17760 \text{ km}$$

Stud safety coefficient

$$F_a/P_a = 950 / 370 = 2.5$$

Bearing safety coefficient

$$C_{or}/P_r = 5100 / 370 = 13,7$$

For further details, contact the NADELLA Technical Service.

Guide rail order code

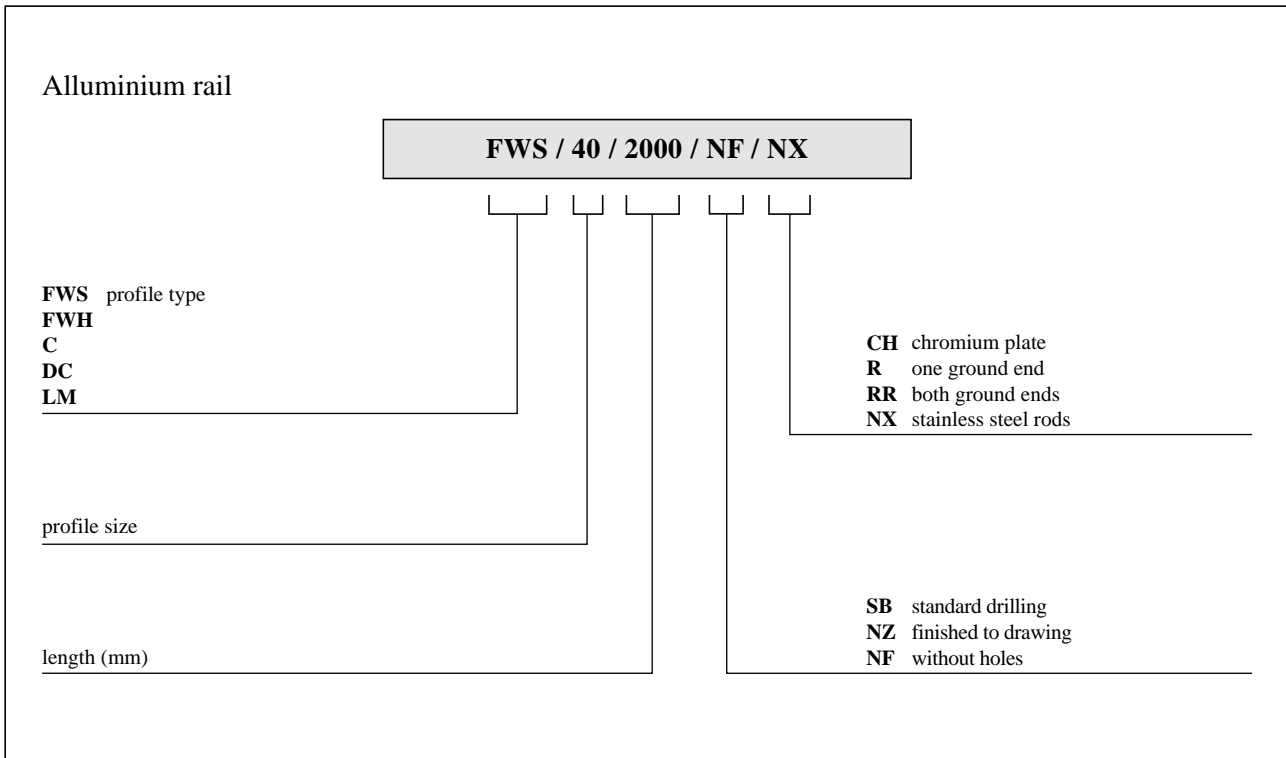
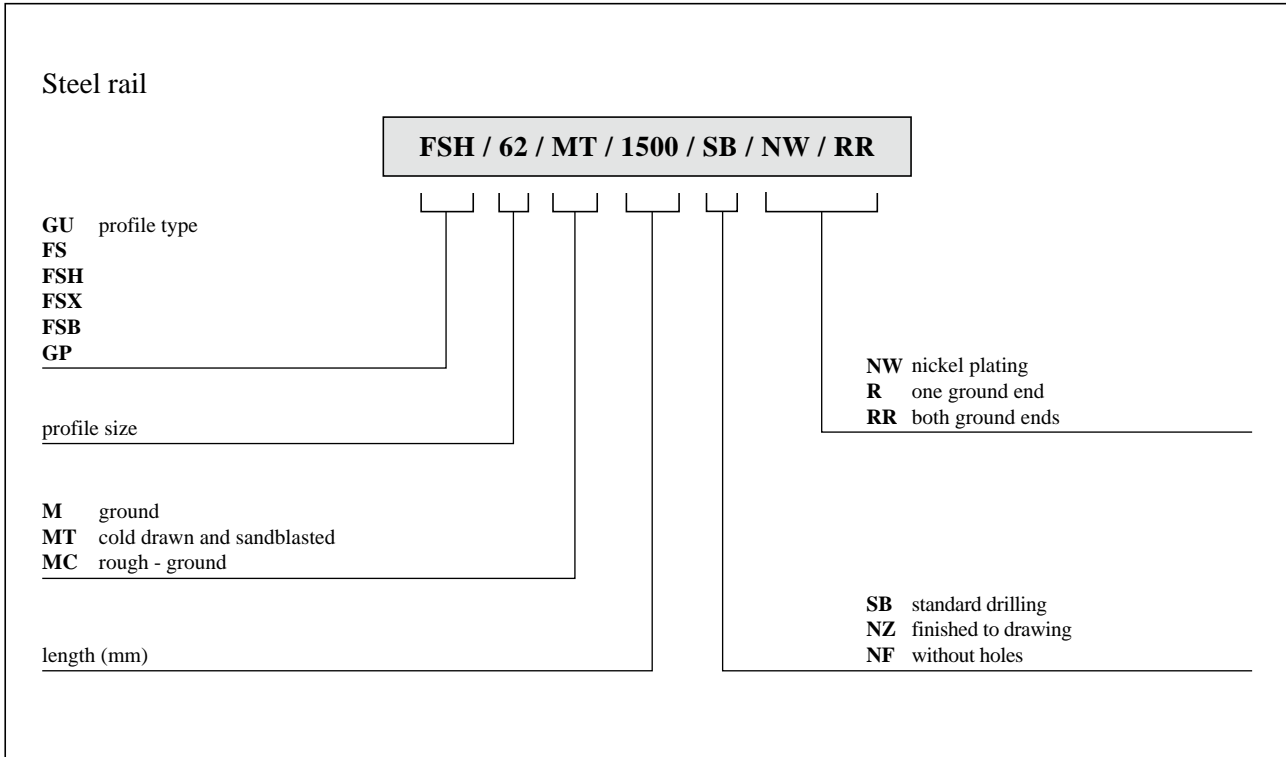

GU System

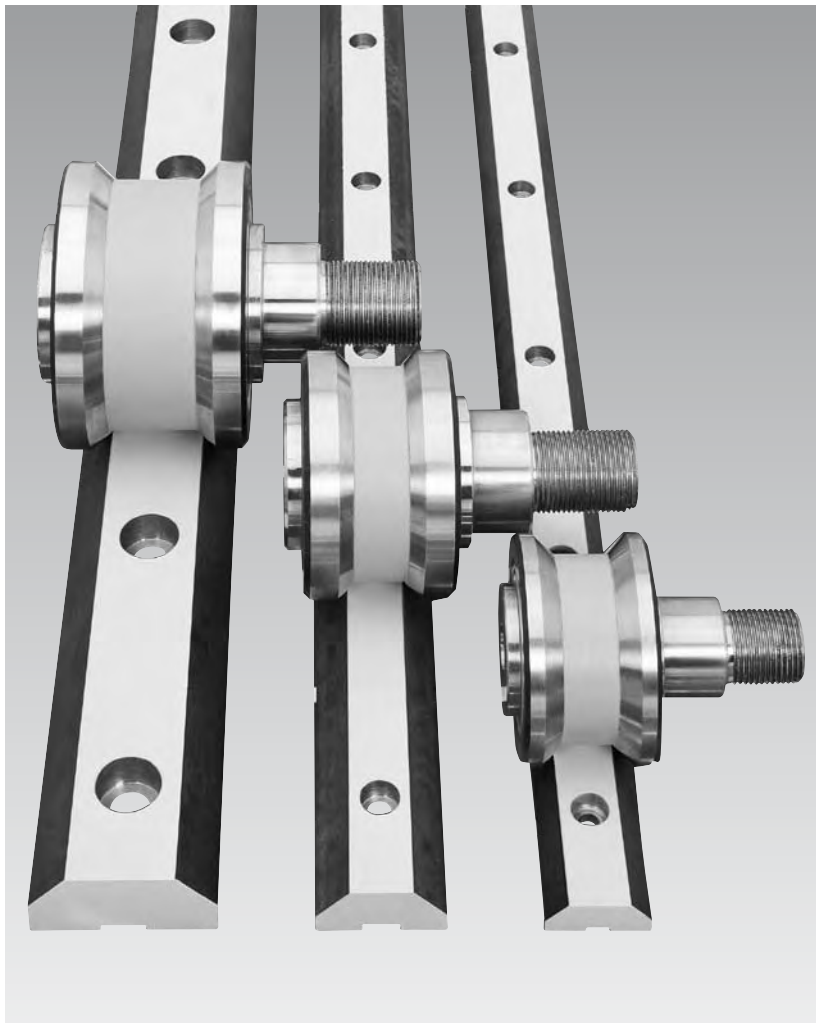

NADELLA

Guide Rails GU..M - GU..MT

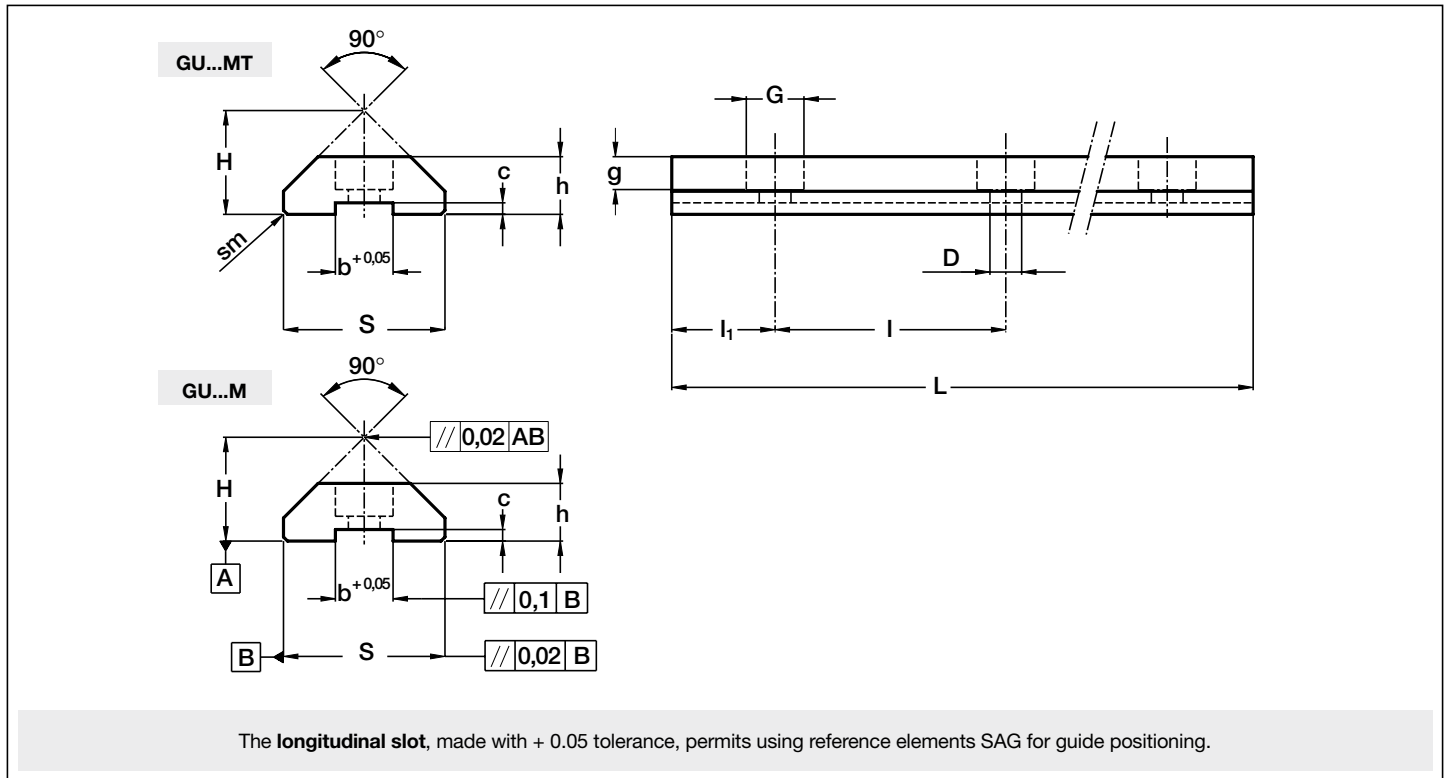

Type	Dimensions (mm)											Weight (kg/m) ⁽²⁾
	H ± 0.05	h ± 0.05	S ± 0.05	D + 0.1	G	g	b + 0.05	c ± 0.05	sm	I	I ₁	
GU 28 MT	19	11	28.8	5.5	10	5.7	10	2.5	0.7x45°	90	30	1.97
GU 35 MT	23.9	15.7	35.5	6.6	11	6.8	10	3.8	1x45°	90	30	3.35
GU 50 MT	35.5	21	50.8	11	18	11	16	4.3	1x45°	90	30	6.89

max length in single element L=6 000 mm (1)

Type	Dimensions (mm)											Weight (kg/m) ⁽²⁾
	H ± 0.05	h ± 0.05	S ± 0.05	D + 0.1	G	g	b + 0.05	c ± 0.05	I	I ₁		
GU 28 M	18	10	28	5.5	10	5.7	10	2	90	30	1.8	
GU 35 M	23	15	35	6.6	11	6.8	10	3.3	90	30	3.2	
GU 50 M	34.5	20	50	11	18	11	16	3.8	90	30	6.8	

max length in single element L=4 020 mm (1)

(1) longer rails are supplied in sections with ground butt joints - (2) Weight without holes

Rails finishing

- drawn, induction hardened and sandblasted tracks (**MT**);
- drawn, induction hardened and ground (**M**)
- Induction hardening on raceways only

Hole layout

- holes according to catalogue (**SB**)
- finishes to drawing (**NZ**)
- without holes (**NF**)

Optional features

- ground one end (**R**)
- ground both ends (**RR**)
- chemical Nickel-plating (**NW**)

Example of standard designation: **GU 35 MT/4300/SB**

See page 15 for standard codification

Guide Rollers **RKU**

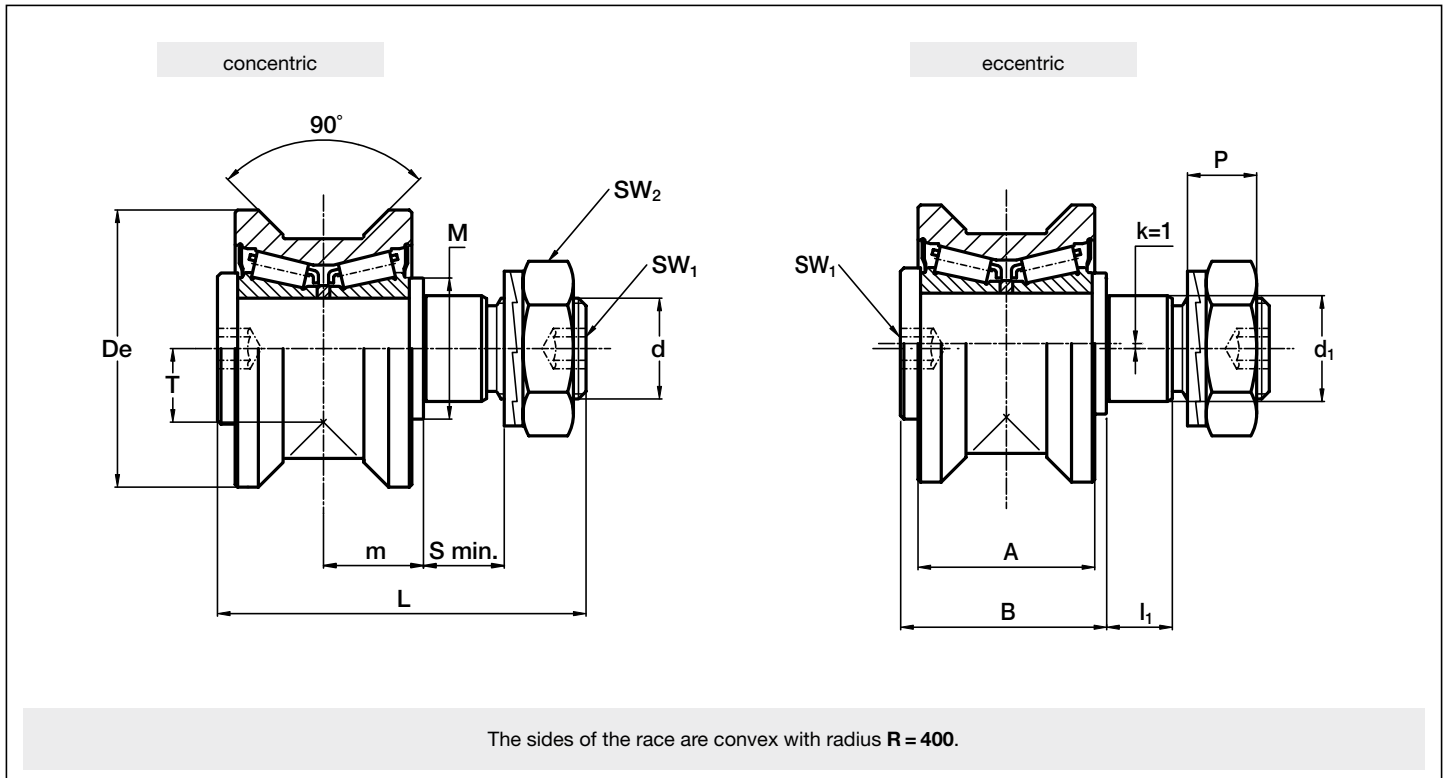

Type		Dimensions (mm)														
concentric	eccentric	De	d ₁ ⁽¹⁾	d	T	m	S min.	P	L	A	B	l ₁	M	SW ₁	SW ₂	k
RKU 55	RKUR 55	55	21	M 20 x 1.5	14.6	19.8	15	13.4	73	35	41	14	28	8	ch. 30	1
RKU 65	RKUR 65	65	27	M 24 x 1.5	18	20.8	19	15.4	83	37	44	18	35	10	ch. 36	1
RKU 75	RKUR 75	75	36	M 30 x 1.5	23.7	27	19	21.6	100	45	55	18	44	12	ch. 46	1
RKU 95	RKUR 95	95	38	M 36 x 1.5	25.5	30	24	24.6	115	53	62	23	50	14	ch. 55	1
RKU 115	RKUR 115	115	42	M 36 x 1.5	33.5	34	33	24.6	135	53	63 ⁽⁵⁾	32	56	14	ch. 55	1

Type		Bearing rating (N)			Limit loads (N)		Life coefficients				Torque wrench settings ⁽²⁾ (Nm)	Weight (kg)
		Dynamic	Static				P _a /P _r ≤ 0.1		P _a /P _r > 0.1			
			C _w ⁽⁶⁾	radial C _{or}	axial C _{oa}	radial F _r	axial F _a	X	Y	X		
RKU 55	RKUR 55	41 650	44 000	12 400	11 900	4 250	1	4.67	0.77	6.98	80	0.6
RKU 65	RKUR 65	46 800	50 400	12 750	22 100	6 800	1	3.93	0.74	6.55	160	0.9
RKU 75	RKUR 75	66 700	72 000	18 900	31 300	10 100	1	4.67	0.77	6.98	300	1.6
RKU 95	RKUR 95	116 800	136 000	37 800	43 700	12 600	1	3	0.8	4.96	450	2.8
RKU 115	RKUR 115	182 450	195 000	50 000	55 600	17 900	1	4.26	0.72	7.1	450	4.9

1) Housing bore tolerance: H7

2) The torque wrench settings are given for non-lubricated threads; for lubricated threads, multiply figure by 0.8

3) Standard seals: material NBR, RS type

4) On request, the guide rollers can be supplied in AISI 440 stainless steel (suffix **NX**) and with Viton seals for operating temperatures up to 120 °C (suffix **V**, no available for RKU 115)

5) Dimensions relating to the stainless-steel rollers (suffix **NX**)

6) C_w basic load for 100 km

7) The guide rollers include self-locking washers and hexagonal nut (DIN 439B) for fitting

8) Pressure angle α for load calculation: 45°

Guide wheels **FKU**

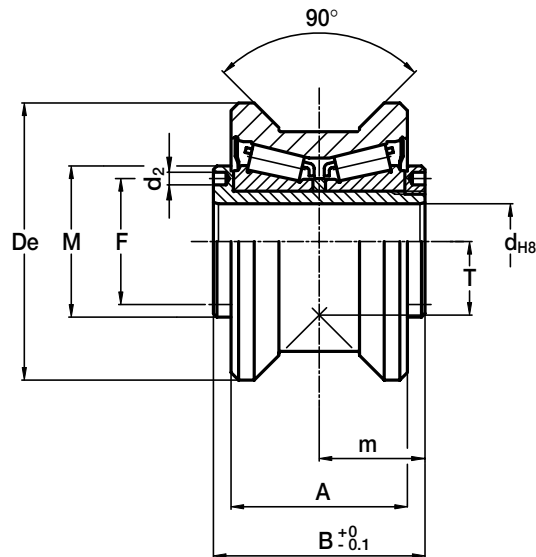

The sides of the race are convex with radius $R = 400$.

Type	Dimensions (mm)								
	De	d	T	m	A	B	F	d ₂	M
FKU 55	55	15	14.6	21	35	42	25	2.5	30
FKU 65	65	20	18	22.5	37	45	29	3	35
FKU 75	75	25	23.7	28	45	56	37	4	44
FKU 95	95	28	25.5	32	53	56 ⁽²⁾	42	4	49
FKU 115	115	35	33.5	36	60	63 ⁽²⁾	52	4	59

Type	Bearing rating (N)			Life coefficients				Weight (kg)
	Dynamic C _w ⁽³⁾	Static		P _a /P _r ≤ 0.1		P _a /P _r > 0.1		
		radial C _{or}	axial C _{oa}	X	Y	X	Y	
FKU 55	41 650	44 000	12 400	1	4.67	0.77	6.98	0.5
FKU 65	46 800	50 400	12 750	1	3.93	0.74	6.55	0.6
FKU 75	66 700	72 000	18 900	1	4.67	0.77	6.98	1.2
FKU 95	116 800	136 000	37 800	1	3	0.8	4.96	2.3
FKU 115	182 450	195 000	50 000	1	4.26	0.72	7.1	3.9

- 1) On request, the guide rollers can be supplied in AISI 440 stainless steel (suffix **NX**) and with Viton seals for operating temperatures up to 120 °C (suffix **V**)
- 2) Dimensions relating to the stainless-steel rollers (suffix **NX**)
- 3) C_w basic load for 100 km
- 4) To prevent rotation between roller and shaft a pin can be fitted in one of the holes "d₂" positioned in the side flange
- 5) Pressure angle α for load calculation: 45°
- 6) Standard seals: material NBR, RS type

Lubricator **LUBU** **NEW**

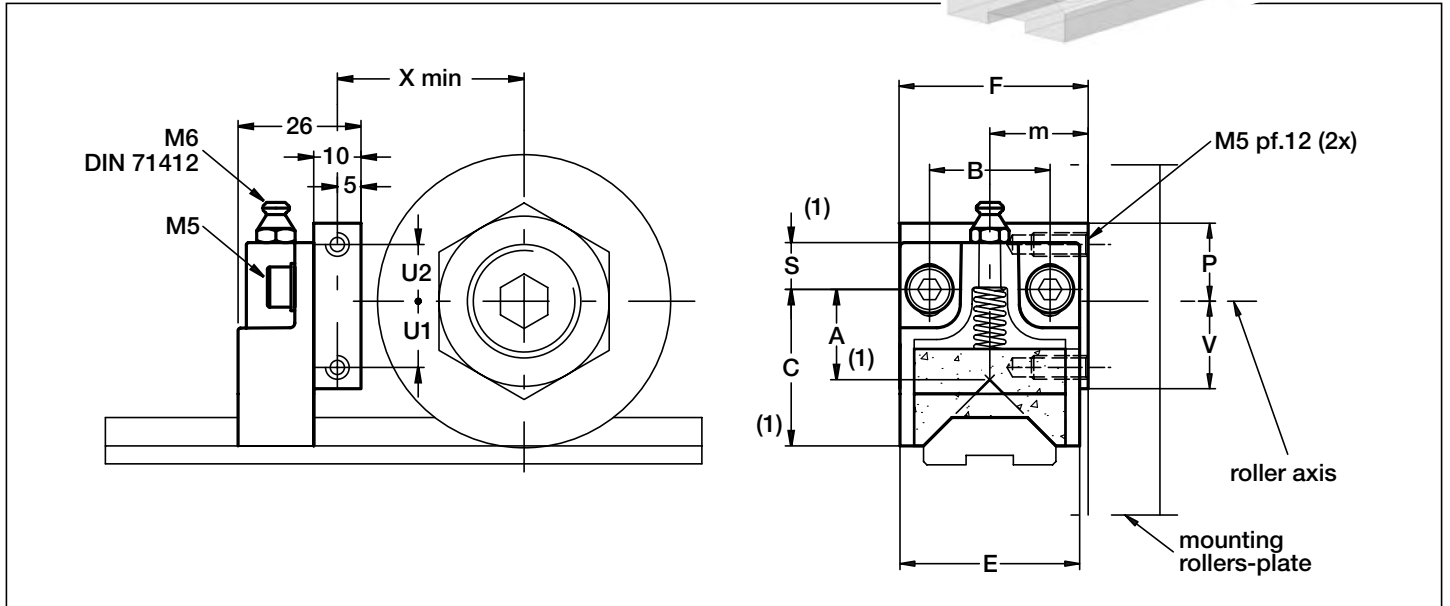
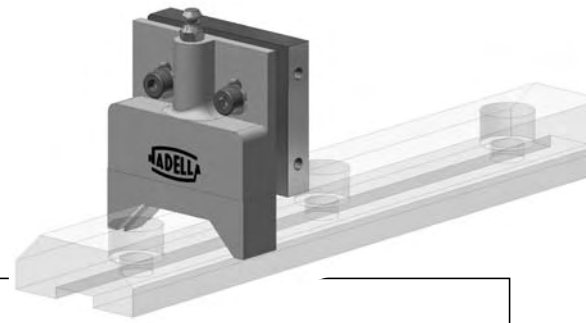

Type	Dimensions (mm)												Weicht (g)	Suggested combinations
	X	U1	U2	F	m	B	S	C	A	E	V	P		
LUBU 55	35	12	14	40	19.8	25.5	10	34	20	38	16.5	18.5	65	RKU 55 RKUR 55 FKU 55
LUBU 65	40	14	12	40	20.8	25.5	10	34	20	38	18.5	16.5	65	RKU 65 RKUR 65 FKU 65
LUBU 75	45	19	11	50	27	25.5	10	43	25.4	44	24	16	85	RKU 75 RKUR 75 FKU 75
LUBU 95	55	21	9	60	30	30	16.5	50	24.9	58	31	19	140	RKU 95 RKUR 95 FKU 95
LUBU 115	65	30	0	63	34	30	16.5	50	24.9	58	40	10	140	RKU 115 RKUR 115 FKU 115

1) The dimension of the plastic part refers to the centre of the regulation-slot. Allows a translation of +/- 3 mm.

2) The lubricator is supplied with the felt already lubricated. The lubricant has a mineral oil base.

3) During the mounting fix the aluminium support to the rollers plate, adjust the height of the plastic part in order to put it in contact with the raceways and than block it in that position with the M5 screws.

Guide pins **SAG**

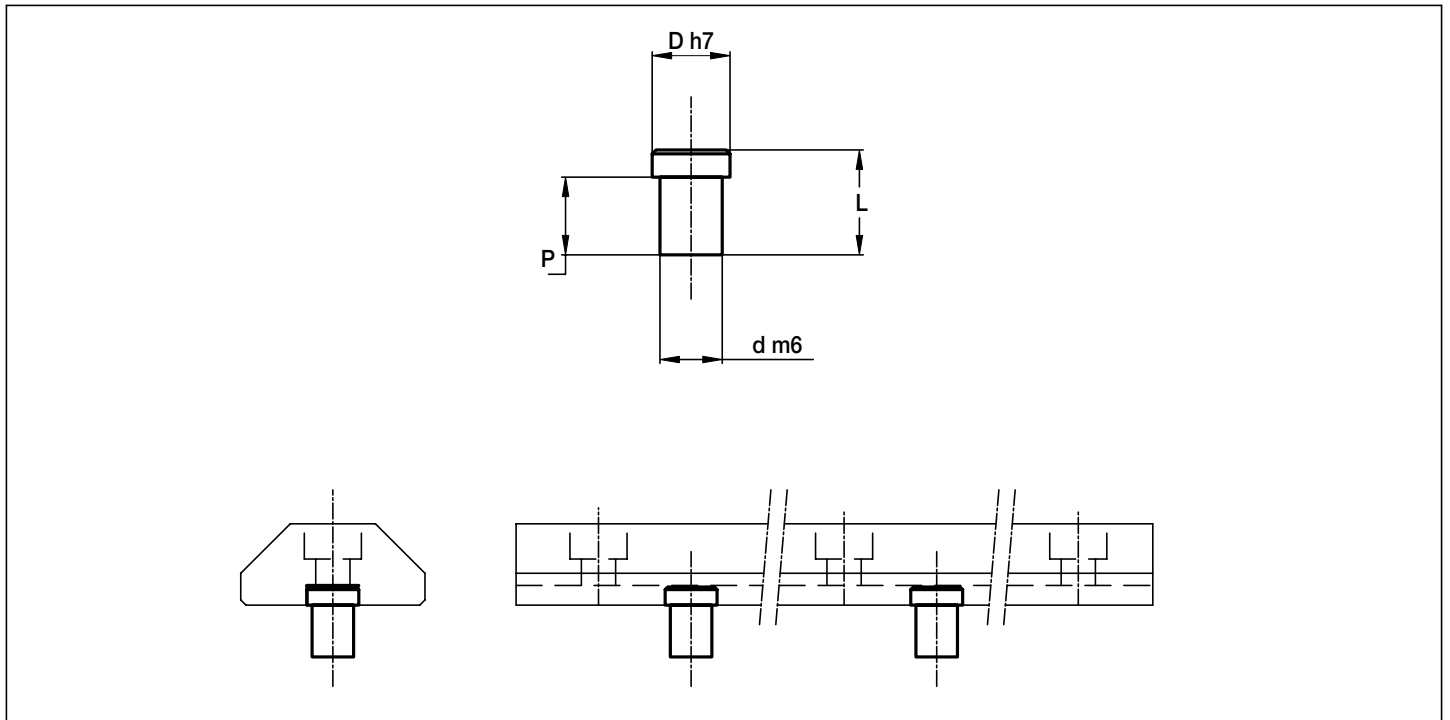
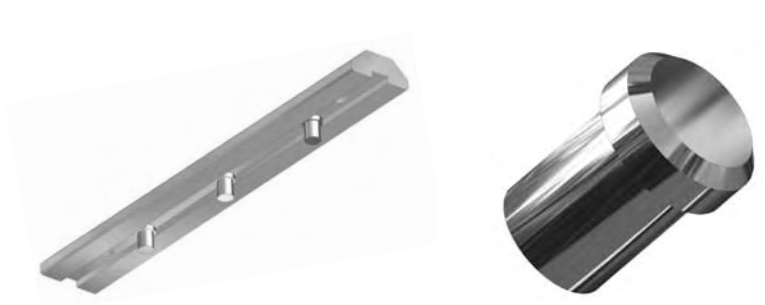

Pin type	Guide type	Dimensions (mm)			
		D	d ⁽¹⁾	P	L
SAG 28	GU 28 MT	10	8	10.0	12.3
SAG 35	GU 35 MT	10	8	10.0	13.5
SAG 50	GU 50 MT	16	10	11.2	15.0

1) Housing bore tolerance: H7

Guide roller combinations

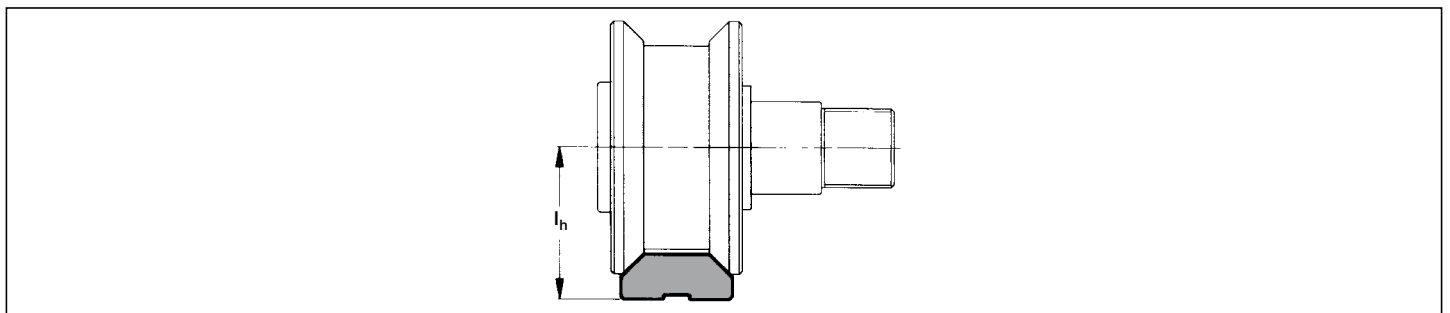

Guide \ Roller	l_h (mm)				
	RKU 55	RKU 65	RKU 75	RKU 95	RKU 115
GU 28 MT	33.6	37	–	–	–
GU 28 M	32.6	36	–	–	–
GU 35 MT	–	41.9	47.6	–	–
GU 35 M	–	41	46.7	–	–
GU 50 MT	–	–	–	61	69
GU 50 M	–	–	–	60	68

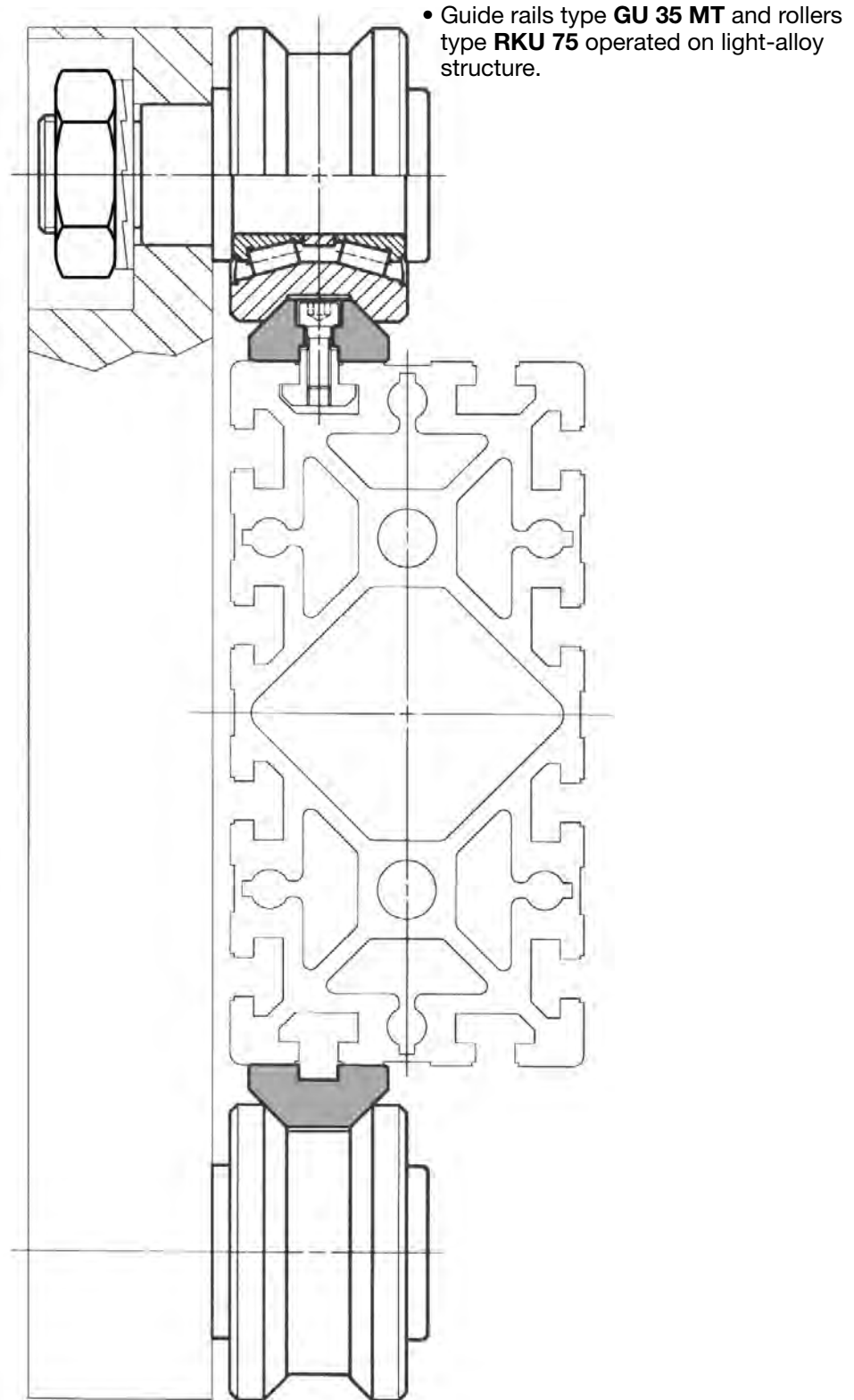

ROLBLOC System



NADELLA

ROLBLOC system

The carriages based on Rolbloc's system are recommended for applications with heavy loads, high frequency of work and aggressive environment (dust, abrasive).

For the profiled guide rollers, the contact between the rollers and the rail takes place on the ground raceways, which are inclined respect the rotation axis of the guide roller. Due to this inclination angle in the contact area there is a dragging proportional to the dimension of the contact area and to the value of the inclination angle. In the ROLBLOC system the rotation axes of the roller guides are parallel to the raceways of the rail, with the following pure rolling. The pure rolling recedes the superficial stress and the effects of the dust between the surfaces.

Technical features

ROLBLOC carriages **BL2..** and **BL4..** are composed by a body in burnished steel on which are mounted two or four roller guides equipped with tapered rollers (similar to flat roller guides type PK..C). The final part of the code (that can be 52, 75 or 115) shows the external diameter of the roller guides.

MBL carriages are composed by an alluminium body provided, on one side, with four threaded screws that allow the direct mounting on the fixing plate. Besides, in order to facilitate the aligning, there are also two pin screws. The body is equipped with guide rollers with a double row angular contact ball bearing. On the body are mounted three guide rollers according to the following combinations:

- **MBL 335-1**: three concentric guide rollers, of which one on the fixing side;
- **MBL 335-2**: three concentric guide rollers, of which two on the fixing side;
- **MBLR 335-1**: three concentric guide rollers, of which one on the fixing side;
- **MBLR 335-2**: three concentric guide rollers, of which two on the fixing side.

MBL 335-.. carriages are dissymmetrical components. In order to fully utilize the load capacity of the carriages it is necessary to consider the main load direction and than put the two coupled guide rollers in that direction.

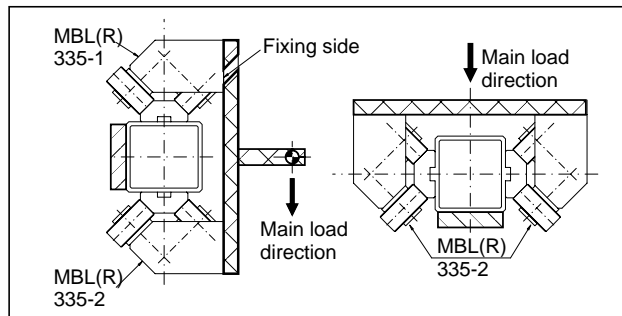

MBL components are checked with the same method used for ROLBLOC BL, but it is very important to consider the exact bearing ratings that must be correct for the load direction. When the axial load (perpendicular to the fixing side of the carriage, or parallel to the fixing side of the rail) is in the direction of the two coupled guide rollers, as for the sketch above, you must use the coefficient with the number 2 (C_{oa2} , F_{a2} , Y_2), otherwise with the number 1 (C_{oa1} , F_{a1} , Y_1).

Mounting instructions

For the mounting of the carriages BL or MBL, with two, three and four guide rollers, are necessary at least two carriages on every rail. A slider realised with only two carriages for rail is not steady (see sketch below).

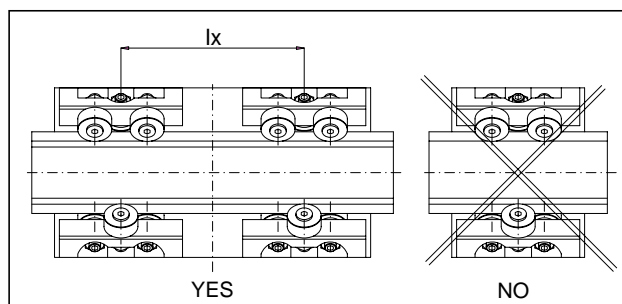

Pay the maximum attention during the setting of the eccentricity of the eccentric guide rollers in order to avoid excessive preloads that can reduce the lifetime of the system. Setting the eccentric guide rollers by rotating the stud anticlockwise (respect the head side of the guide roller).

Guide Rails **GU..M** **GU..MT**

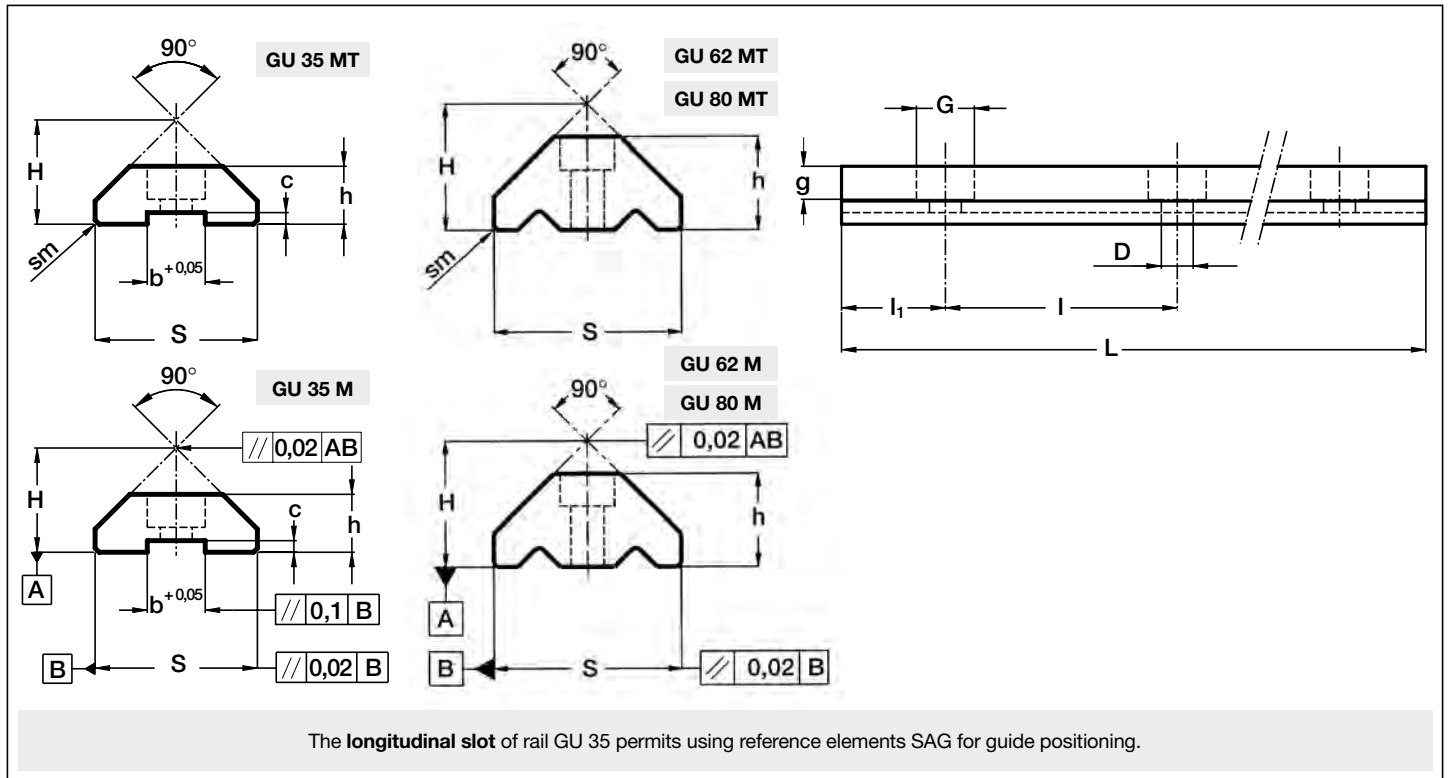

Type	Dimensions (mm)											Weight (kg/m) ⁽²⁾
	H ± 0.05	h ± 0.05	S ± 0.05	D + 0.1	G	g	b + 0.05	c ± 0.05	sm	l	l ₁	
GU 35 MT	23.9	15.7	35.5	6.6	11	6.8	10	3.8	1x45°	90	30	3.35
GU 62 MT	43.5	32.5	63.5	11	18	11	-	-	2x45°	120	30	11.80
GU 80 MT	56.7	41.5	81.5	13.5	20	13	-	-	2x45°	120	30	20.30

max length in single element L = 6 000 mm (1)

Type	Dimensions (mm)											Weight (kg/m) ⁽²⁾
	H ± 0.05	h ± 0.05	S ± 0.05	D + 0.1	G	g	b + 0.05	c ± 0.05	l	l ₁		
GU 35 M	23	15	35	6.6	11	6.8	10	3.3	90	30	3.2	
GU 62 M	42	31	62	11	18	11	-	-	120	30	10.9	
GU 80 M	55.2	40	80	13.5	20	13	-	-	120	30	20	

max length in single element L = 4 020 mm (1)

(1) longer rails are supplied in sections with ground butt joints - (2) Weight without holes

Rails finishing

- drawn, induction hardened and sandblasted tracks (**MT**);
- drawn, induction hardened and ground (**M**)
- Induction hardening on raceways only

Hole layout

- holes according to catalogue (**SB**)
- finishes to drawing (**NZ**)
- without holes (**NF**)

Optional features

- ground one end (**R**)
- ground both ends (**RR**)
- chemical Nickel-plating (**NW**)

Example of standard designation: **GU 62 MT/4300/SB**

See page 15 for standard codification

Carriages MBL

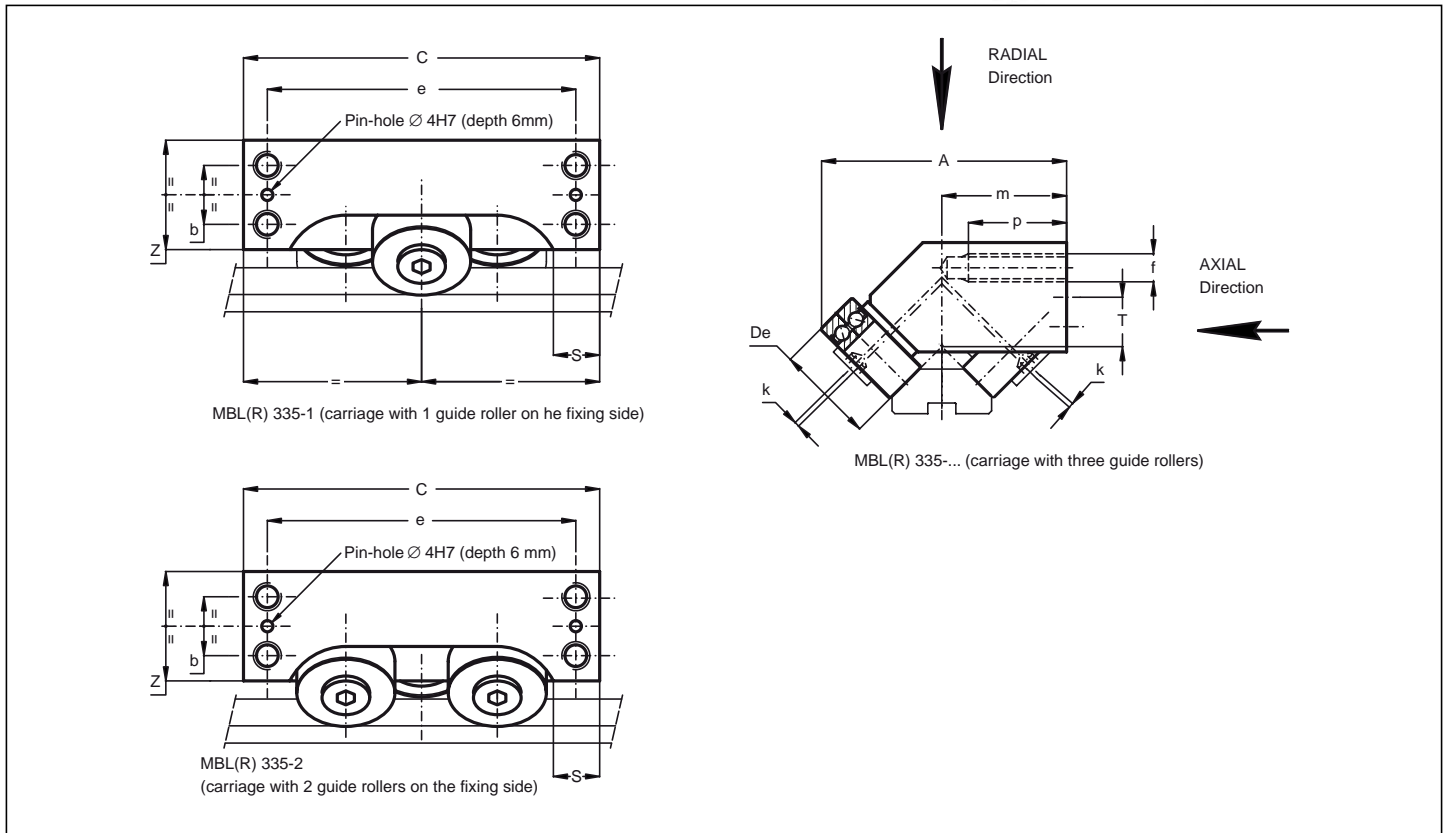

Type		Dimensions (mm)											Weight (kg)	
concentric	eccentric	A	C	S	m	e	b	p	f	k ⁽²⁾	T	Z		De
MBL 335-1	MBLR 335-1	87.5	127	16.5	44.5	110	21	35	M10	0.75	17.6	39	35	0.94
MBL 335-2	MBLR 335-2													

Type		Bearing ratings (N)				Limit loads (N)			Life coefficients		
		Dynamic $C_w^{(3)}$	radial C_{or}	Static		radial F_r	axial F_a		X	Y	
				$C_{oa1}^{(5)}$	$C_{oa2}^{(6)}$		$F_{a1}^{(5)}$	$F_{a2}^{(6)}$		$Y_1^{(5)}$	$Y_2^{(6)}$
MBL 335-1	MBLR 335-1	14 500	7 000	3 500	7 000	8 400	4 200	8 400	1	1	0
MBL 335-2	MBLR 335-2										

- 1) Standard seals metallic ZZ
- 2) Maximum value of eccentricity for carriages MBLR, where all the guide rollers are eccentric
- 3) C_w basic load for 100 km, radial load
- 4) Pressure angle α for load calculation: 45°
- 5) Bearing ratings you must use when the axial load is in the direction of the side with one guide roller only
- 6) Bearing ratings you must use when the axial load is in the direction of the side with two guide rollers

Carriages BL

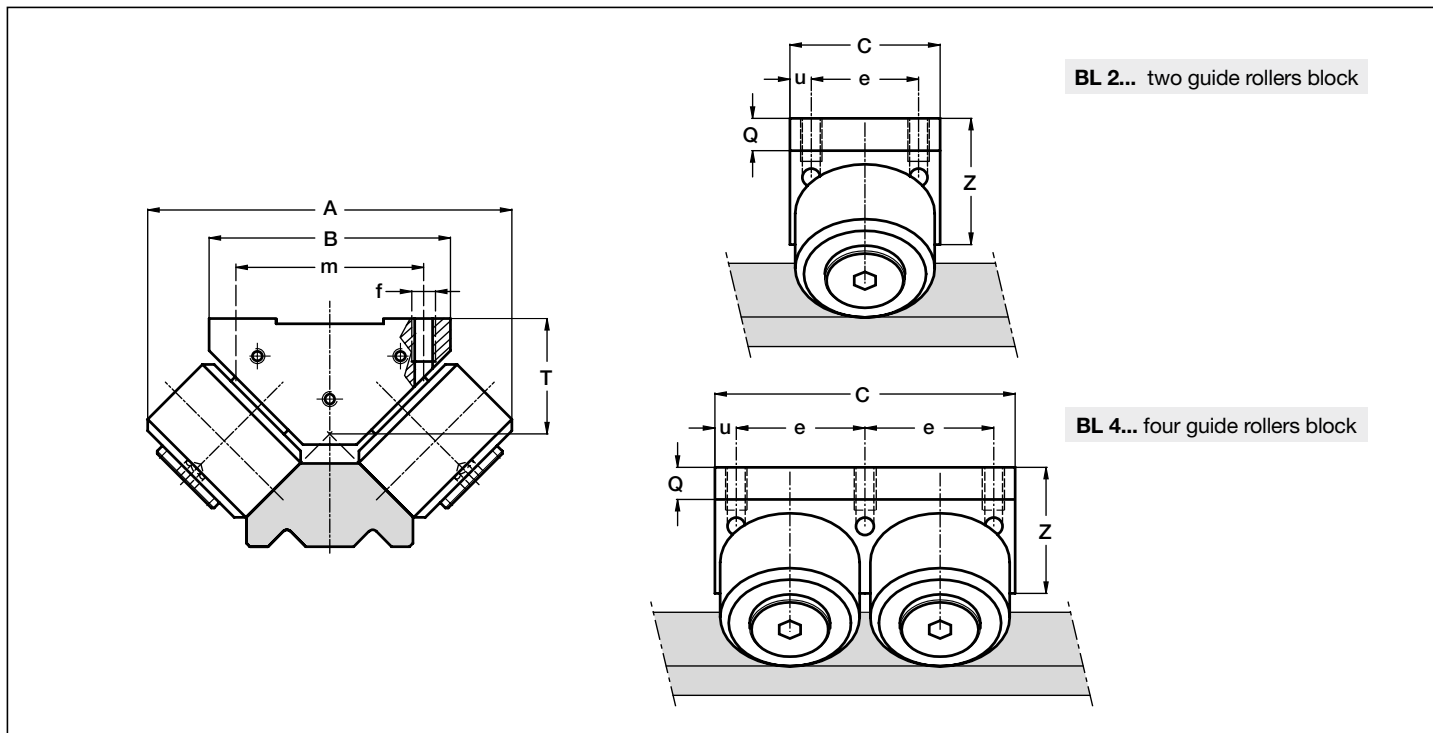

Type	Dimensions (mm)										Weight (kg)
	A	B	C	m	e	u	f	Q	T	Z	
BL 2 52	136	90	56	70	40	8	M 8	12	43	47	2.4
BL 4 52	136	90	112	70	48	8	M 8	12	43	47	4.8
BL 2 75	170	125	76	85	56	10	M 12	17.1	71.5	70	6.5
BL 4 75	170	125	152	85	66	10	M 12	17.1	71.5	70	13
BL 2 115	243	170	125	120	95	15	M 14	22	99.8	93	21.6
BL 4 115	243	170	250	120	110	15	M 14	22	99.8	93	43.2

Type	Bearing rating (N)			Limit loads (N)		Life coefficients	
	Dynamic $C_w^{(3)}$	Static		Radial $F_r^{(4)}$	Axial $F_a^{(5)}$	X	Y
		radial $C_{or}^{(4)}$	axial $C_{oa}^{(5)}$				
BL 2 52	59 000	62 200	31 100	16 800	8 400	1	1
BL 4 52	118 000	124 400	62 200	33 600	16 800	1	1
BL 2 75	96 300	101 800	50 900	44 200	22 100	1	1
BL 4 75	192 600	203 600	101 800	88 400	44 200	1	1
BL 2 115	264 500	276 000	138 000	78 600	39 300	1	1
BL 4 115	529 000	552 000	276 000	157 200	78 600	1	1

- 1) Standard seals: material NBR, RS type
- 2) On request, the guide rollers can be supplied in stainless steel AISI 440 (suffix **NX**) and with Viton seals for operating temperatures up to 120 °C (suffix **V**, up to dimension BL.... 75 included)
- 3) C_w basic load for 100 km, load perpendicular to the roller side fixing surface
- 4) Loads perpendicular to the roller side fixing surface
- 5) Loads parallel to the roller side fixing surface
- 6) Pressure angle α for loads checking calculation: 45°

Guide Rollers combination

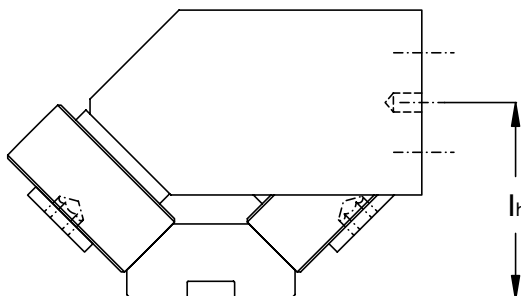

Guide \ Roller	l_h (mm)
	MBL / MBLR
GU 35 MT	41.5
GU 35 M	40.6

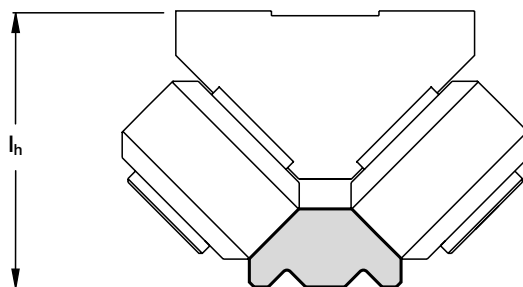

Guide \ Roller	l_h (mm)					
	BL 2 52	BL 4 52	BL 2 75	BL 4 75	BL 2 115	BL 4 115
GU 62 MT	86.5	86.5	115	115	-	-
GU 62 M	85	85	113.5	113.5	-	-
GU 80 MT	-	-	-	-	156.5	156.5
GU 80 M	-	-	-	-	155	155

Mounting Example

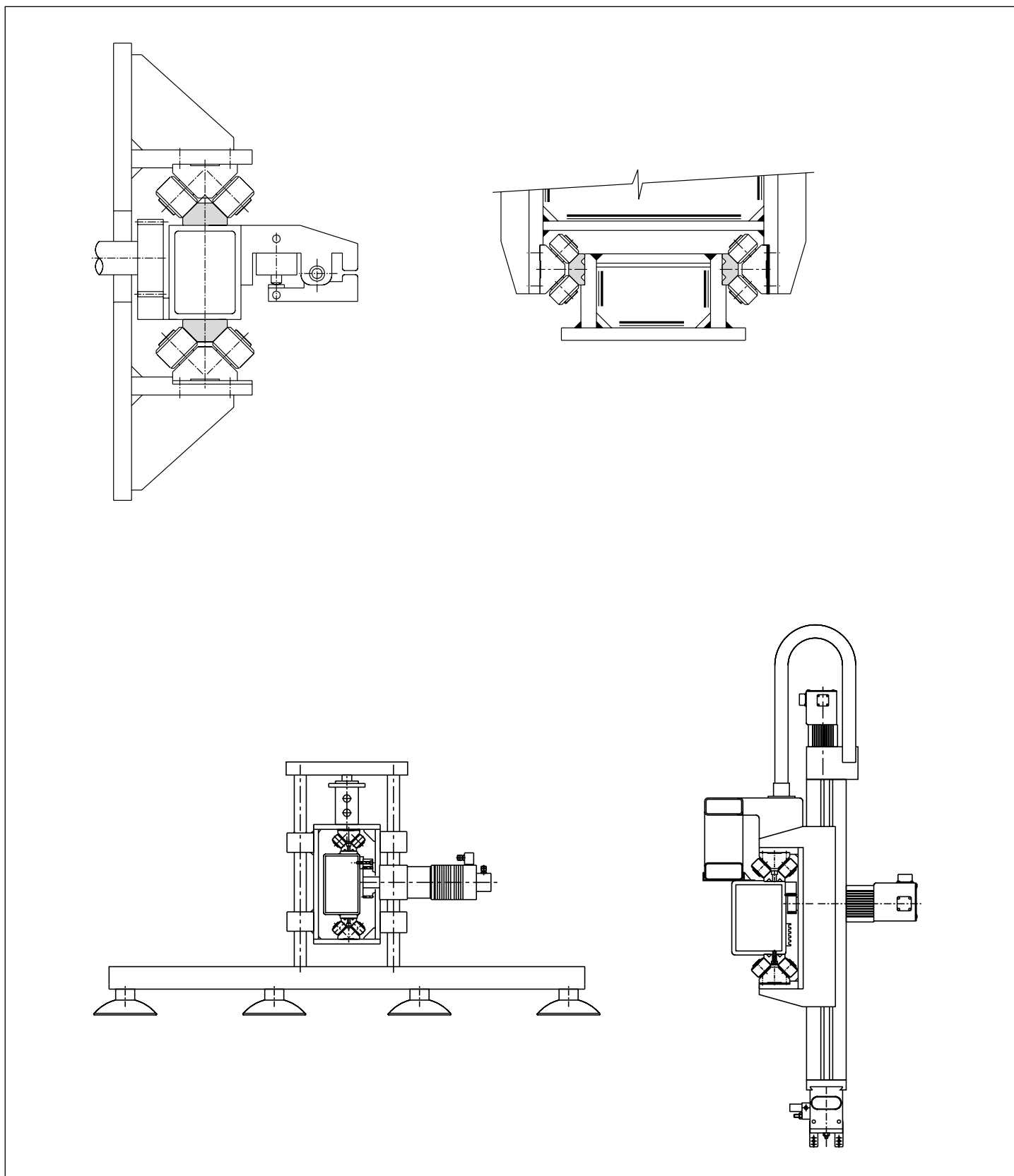

For further details, contact the NADELLA Technical Service.

FS System

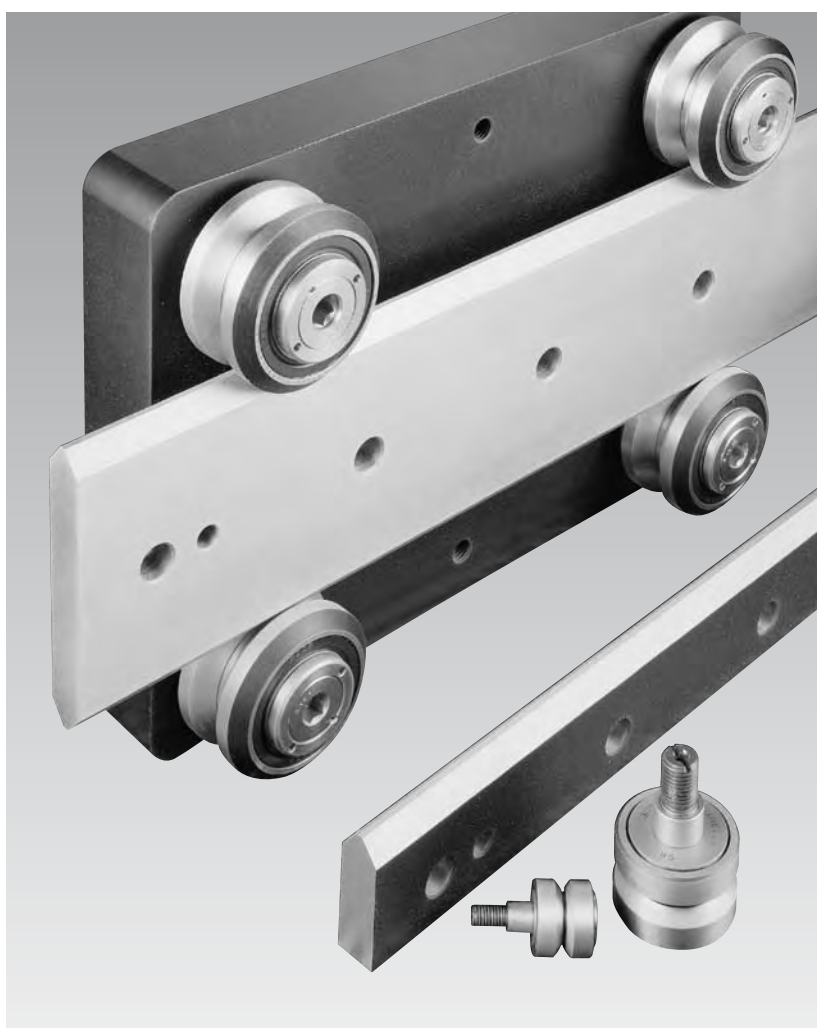

NADELLA

Guide Rails FS..MT

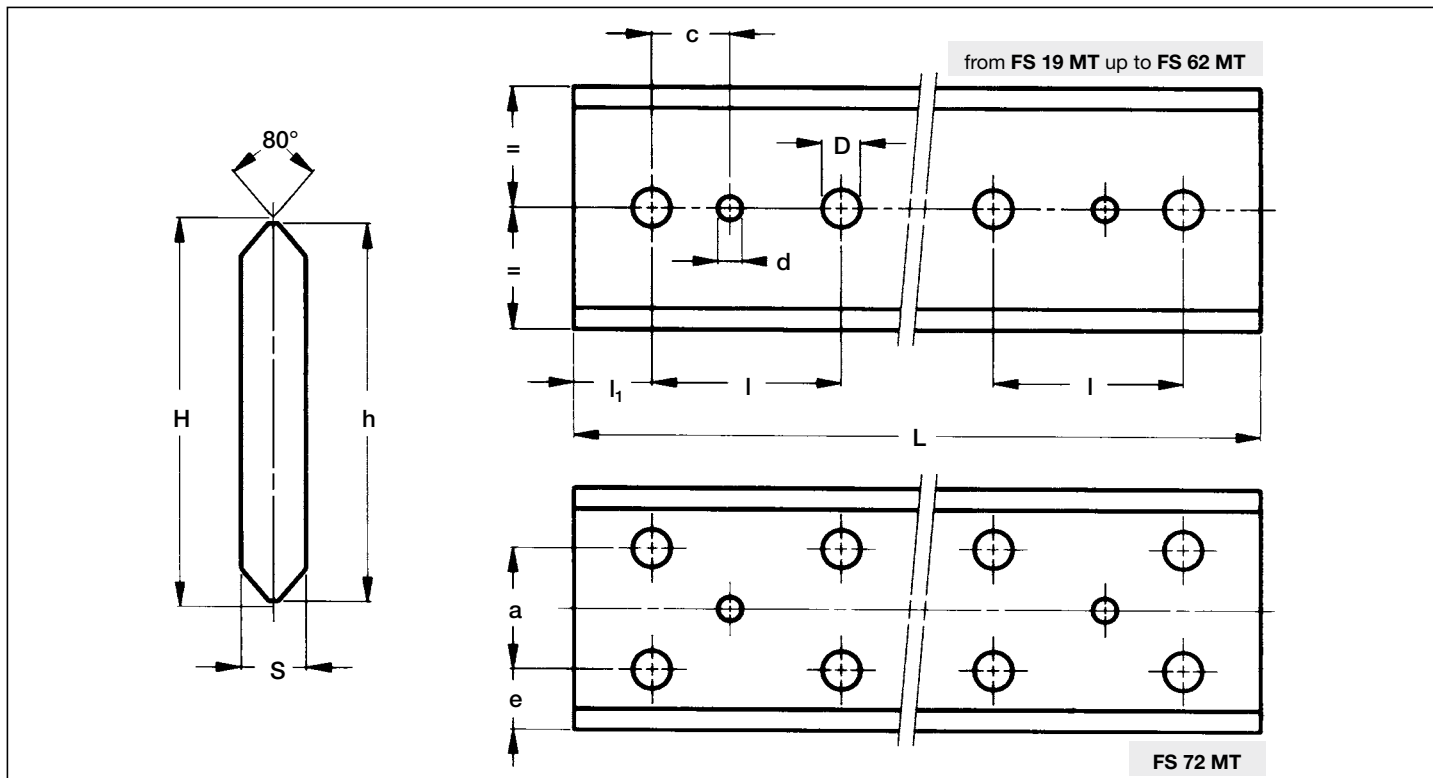

Type	Dimensions (mm)										Weight ⁽²⁾ (kg/m)
	H ± 0.1	h ± 0.1	S ± 0.1	d + 0.05	D	c ⁽²⁾	e	a	l	l ₁	
FS 19 MT	22.2	21	5.3	4	6.5	15	-	-	90	30	0.8
FS 22 MT	28.8	27	5.8	5	6.5	15	-	-	90	30	1.1
FS 32 MT	43.8	42	6.8	6	6.5	15	-	-	90	30	2.1
FS 35 MT	48.8	47	8.8	6	9	20	-	-	90	30	3.0
FS 40 MT	64.5	62	8.8	6	9	20	-	-	90	30	4.1
FS 47 MT	80.15	77.2	11	6	11.5	20	-	-	90	30	6.3
FS 52 MT	91.35	88.2	13	8	13.5	20	-	-	90	30	8.5
FS 62 MT	106	103	15.7	8	13.5	20	-	-	90	30	11.7
FS 72 MT	124.6	121	19	10	17.5	30	30.5	60	90	30	16.9

Maximum length of single guide element L = 6 000 mm (1)

1) Longer rails are supplied in sections with ground butt joints

2) Weight without holes

Rails finishing

- drawn, induction hardened and sandblasted tracks (**MT**);
- Induction hardening on raceways only

Hole layout

- holes according to catalogue (**SB**)
- finishes to drawing (**NZ**)
- without holes (**NF**)

Optional features

- ground one end (**R**)
- ground both ends (**RR**)
- chemical Nickel-plating (**NW**)

Example of standard designation: **FS 52 MT/5280/SB**

See page 15 for standard codification

Guide Rails FS..M

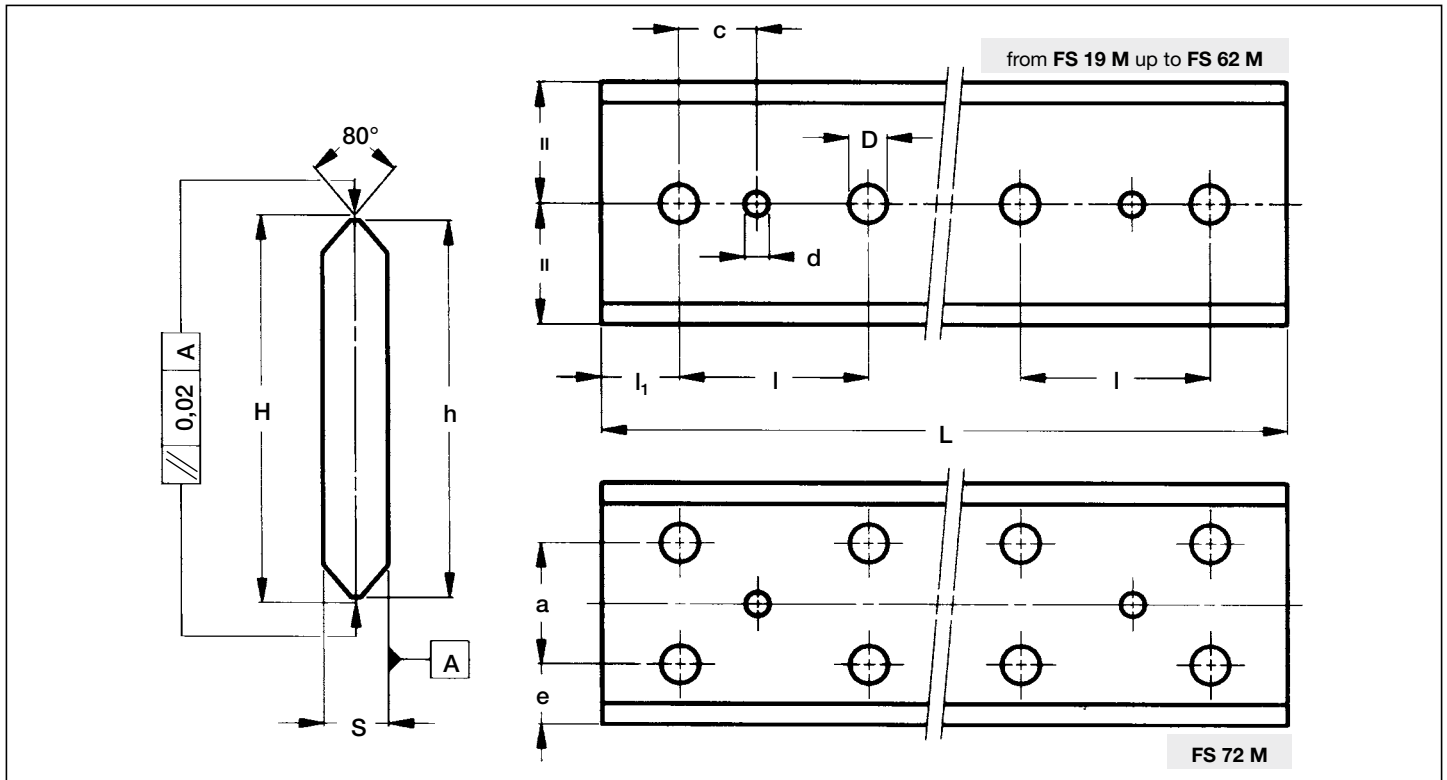

Type	Dimensions (mm)										Weight ⁽²⁾ (kg/m)
	H ± 0.05	h ± 0.1	S ± 0.05	d + 0.05	D	c	e	a	l	l ₁	
FS 19 M	20.95	20	4.5	4	6.5	15	–	–	90	30	0.6
FS 22 M	27.86	26	5	5	6.5	15	–	–	90	30	0.9
FS 32 M	42.86	41	6	6	6.5	15	–	–	90	30	1.8
FS 35 M	47.86	46	8	6	9	20	–	–	90	30	2.6
FS 40 M	63.58	61	8	6	9	20	–	–	90	30	3.7
FS 47 M	78.58	76	10	6	11.5	20	–	–	90	30	5.6
FS 52 M	89.78	87	12	8	13.5	20	–	–	90	30	7.7
FS 62 M	104.76	102	15	8	13.5	20	–	–	90	30	11.2
FS 72 M	122.98	120	18	10	17.5	30	30	60	90	30	15.8

Maximum length of single guide element L = 4,020 mm (1)

1) Longer rails are supplied in sections with ground butt joints

2) Weight without holes

Rails finishing

- drawn, induction hardened and ground profile (**M**);
- Induction hardening on raceways only

Hole layout

- holes according to catalogue (**SB**)
- finishes to drawing (**NZ**)
- without holes (**NF**)

Optional features

- ground one end (**R**)
- ground both ends (**RR**)
- chemical Nickel-plating (**NW**)

Example of standard designation: **FS 40 M/2760/SB**

See page 15 for standard codification

Guide Rails **FSH..MT, FSX..MT**

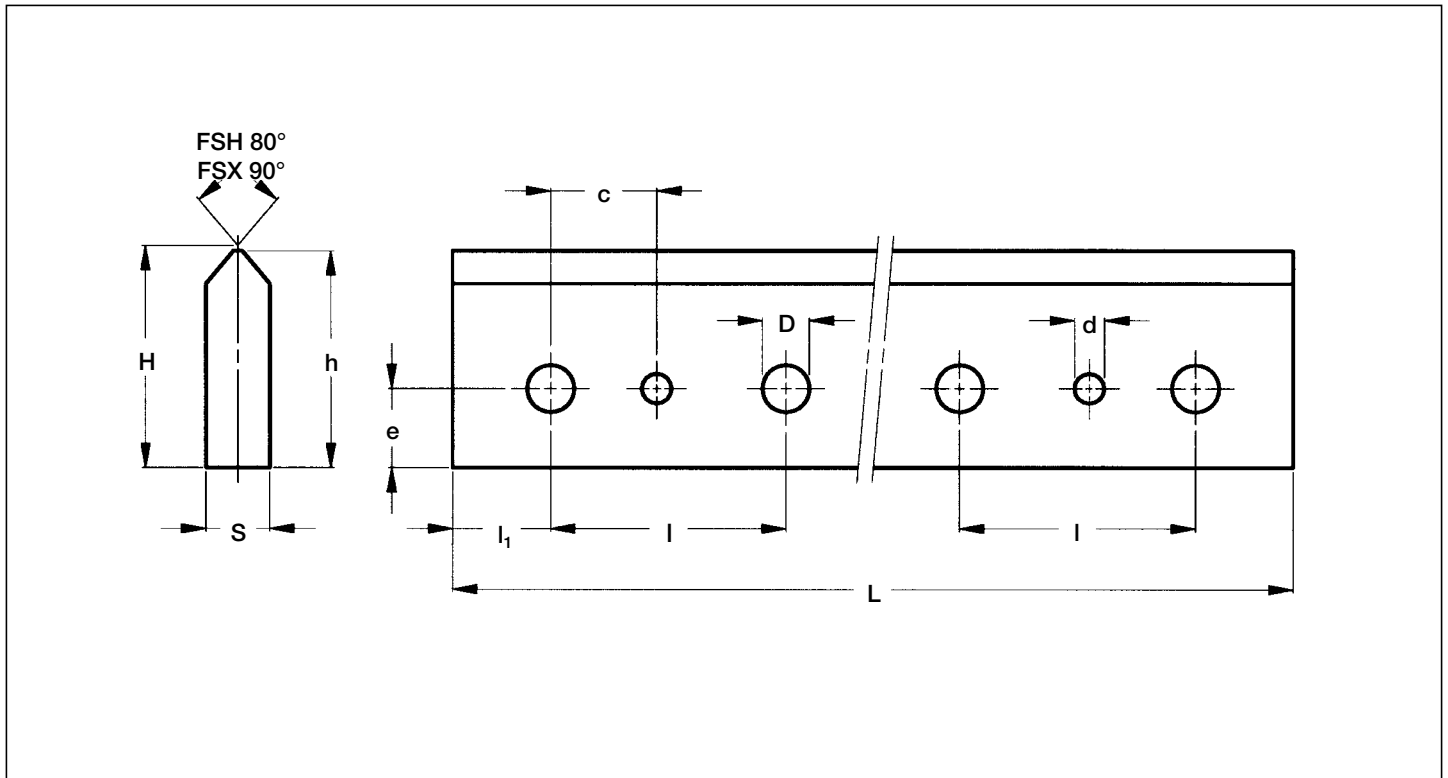

Type	Dimensions (mm)									Weight ⁽²⁾ (kg/m)
	H ± 0.1	h ± 0.1	S ± 0.1	d) + 0.05	D	c	e	l	l ₁	
FSH 22 MT	23.9	23	5.8	5	6.5	15	9	90	30	1.0
FSH 32 MT	29.9	29	6.8	6	6.5	15	11	90	30	1.5
FSH 40 MT	37.2	36	8.8	6	9	20	16	90	30	2.4
FSH 52 MT	40.75	39.2	13	8	13.5	20	17	90	30	3.7
FSH 62 MT	50.75	49.2	16	8	13.5	20	17	90	30	5.7
FSH 72 MT	60.85	59.2	19	10	17.5	30	20	90	30	8.2
FSX 90 MT	62.85	61	26.5	10	13.5	30	22	90	30	11.6

Maximum length of single guide element L = 6 000 mm⁽¹⁾

1) Longer rails are supplied in sections with ground butt joints

2) Weight without holes

Rails finishing

- drawn, induction hardened and sandblasted tracks (**MT**);
- Induction hardening on raceways and base only

Hole layout

- holes according to catalogue (**SB**)
- finishes to drawing (**NZ**)
- without holes (**NF**)

Optional features

- ground one end (**R**)
- ground both ends (**RR**)
- chemical Nickel-plating (**NW**)

Example of standard designation: **FSH 52 MT/5280/SB**

See page 15 for standard codification

Guide Rails **FSH...M, FSX...M**

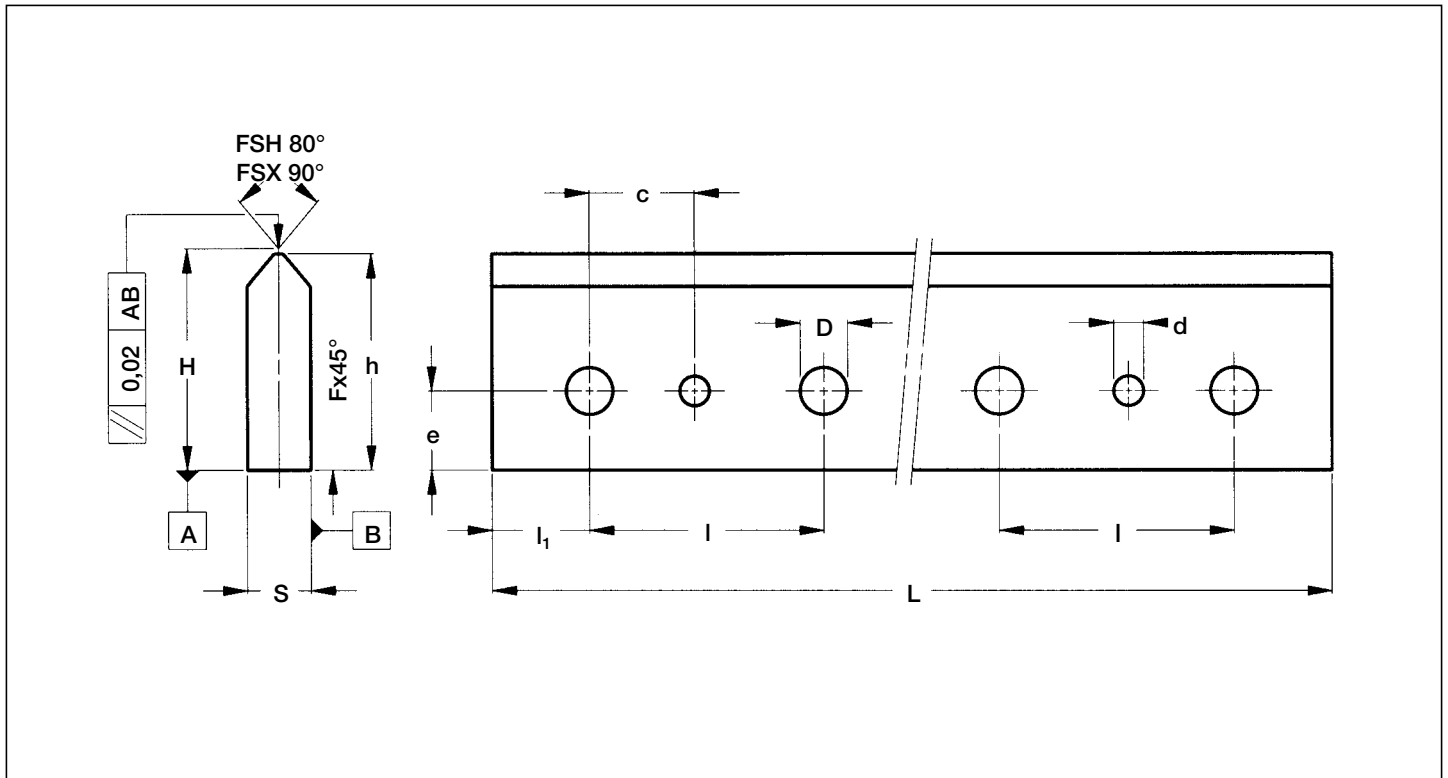

Type	Dimensions (mm)									Weight ⁽²⁾ (kg/m)
	H ± 0.05	h ± 0.1	S ± 0.05	d + 0.05	D	c	e	l	l ₁	
FSH 19 M	18.98	18.5	4.5	4	6.5	15	8	90	30	0.6
FSH 22 M	22.93	22	5	5	6.5	15	9	90	30	0.8
FSH 32 M	28.93	28	6	6	6.5	15	11	90	30	1.2
FSH 40 M	36.29	35	8	6	9	20	16	90	30	2.1
FSH 52 M	39.39	38	12	8	13.5	20	17	90	30	3.4
FSH 62 M	49.38	48	15	8	13.5	20	17	90	30	5.2
FSH 72 M	59.49	58	18	10	17.5	30	20	90	30	7.6
FSX 90 M	61.79	60	26	10	13.5	30	22	90	30	11.0

Maximum length of single guide element L = 4 020 mm⁽¹⁾

1) Longer rails are supplied in sections with ground butt joints

2) Weight without holes

Rails finishing

- drawn, induction hardened and ground profile (**M**);
- Induction hardening on raceways and base only

Hole layout

- holes according to catalogue (**SB**)
- finishes to drawing (**NZ**)
- without holes (**NF**)

Optional features

- ground one end (**R**)
- ground both ends (**RR**)
- chemical Nickel-plating (**NW**)

Example of standard designation: **FSH 40 M/2760/SB**

See page 15 for standard codification

Guide Rails **FSB..MT**

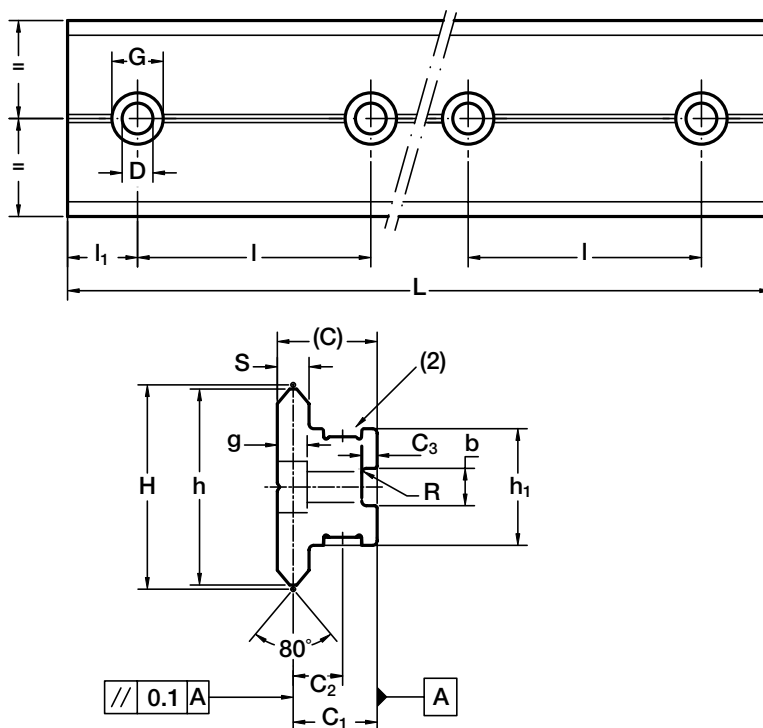

Type	Dimensions (mm)															Weight ⁽³⁾ (kg/m)
	D	G	g	l	l ₁	H ± 0.1	h ± 0.1	S ± 0.1	(C)	C ₁ ± 0.1	C ₂	C ₃	b + 0.05	h ₁	R	
FSB 32 MT	6.6	11	6.8	90	30	43.8	42	6.8	21.4	18	10.6	3.3	8	25	1	4.5
Maximum length of single guide element L = 6 000 mm ⁽¹⁾																

- 1) Longer rails are supplied in sections with ground butt joints
- 2) Option measuring tape, for more information contact technical department
- 3) Weight without holes

Rails finishing

- drawn, induction hardened and sandblasted tracks (**MT**);
- Induction hardening on raceways only

Hole layout

- holes according to catalogue (**SB**)
- finishes to drawing (**NZ**)
- without holes (**NF**)

Optional features

- ground one end (**R**)
- ground both ends (**RR**)
- chemical Nickel-plating (**NW**)

Example of standard designation: **FSB 32 MT/2040/SB**

See page 15 for standard codification

Guide Rollers **FR..EI**

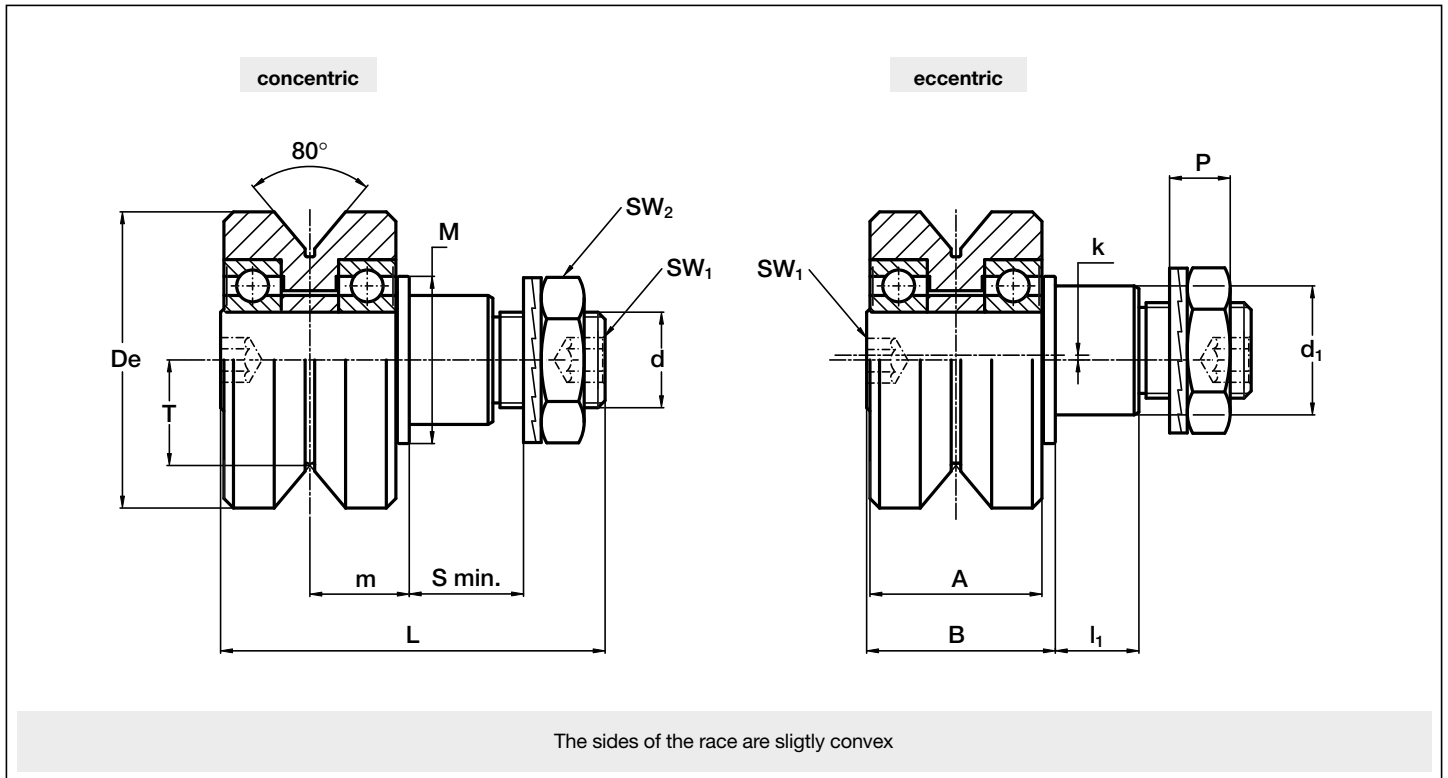

Type		Dimensions (mm)														
concentric	eccentric	De	d ₁ ⁽¹⁾	d	T	m	S min.	P	L	A	B	l ₁	M	SW ₁	SW ₂	k
FR 22 EI	FRR 22 EI	22	9	M 6 x 1	7.7	9.4	9	6.5	37	15	18.2	8	14	4 ⁽⁶⁾	ch. 10	0.5
FR 32 EI	FRR 32 EI	32	14	M 10 x 1.25	11.8	12.6	12	8.5	50.5	21	24.5	11	20	4	ch. 16	1
FR 40 EI	FRR 40 EI	40	16	M 12 x 1.5	14.6	15.5	12	10.4	59.5	28	30.5	11	22	5	ch. 18	1
FR 52 EI	FRR 52 EI	52	21	M 16 x 1.5	19.1	19.8	15	11.4	69.5	32	36.5	14	28	6	ch. 24	1,5
FR 62 EI	FRR 62 EI	62	27	M 20 x 1.5	22.1	20.8	18.5	12.4	80.5	36	39.5	17.5	35	8	ch. 30	2

Type		Bearing rating (N)			Limit loads (N)		Life coefficients		Torque wrench ⁽²⁾ settings (Nm)	Weight (kg)
		Dynamic	Static							
			C _w ⁽⁴⁾	radial C _{or}	axial C _{oa}	radial F _r	axial F _a	X		
FR 22 EI	FRR 22 EI	1 800	1 080	350	1 700	720	1	2.20	3	45
FR 32 EI	FRR 32 EI	4 400	2 330	750	1 200	500	1	2.92	20	130
FR 40 EI	FRR 40 EI	7 350	4 000	1 300	3 000	1 300	1	2.75	26	260
FR 52 EI	FRR 52 EI	9 500	5 500	1 750	7 500	3 000	1	2.96	64	510
FR 62 EI	FRR 62 EI	15 500	8 500	2 750	10 900	4 200	1	3.07	120	820

1) Housing bore tolerance: H7

2) The torque wrench settings are given for non-lubricated threads; for lubricated threads, multiply figure by 0.8

3) On request, the guide rollers can be supplied in AISI 440 stainless steel (suffix **NX**)

4) C_w basic load for 100 km

5) The guide rollers are complete with self-locking washers and hexagonal nut (DIN 439B) for fitting

6) Pressure angle α for load calculation: 40°

7) NBR seals RS type

8) Screw driver slot on the stud side

Guide Rollers **FRN..EI**

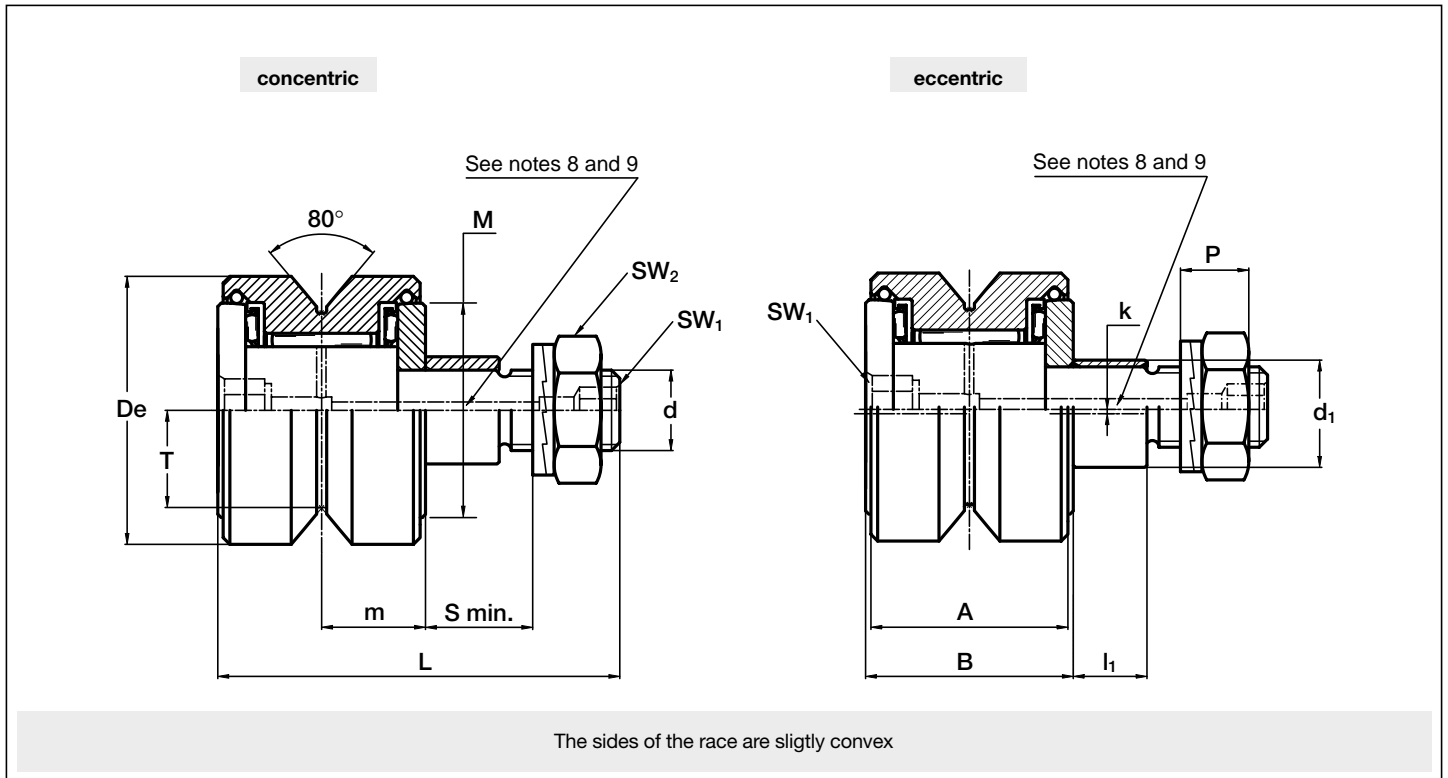

Type		Dimensions (mm)														
concentric	eccentric	De	d ₁ ⁽¹⁾	d	T	m	S min.	P	L	A	B	l ₁	M	SW ₁	SW ₂	k
FRN 19 EI ⁽⁸⁾	FRNR 19 EI ⁽⁸⁾	19	7	M 5 x 0.8	7	8.8	6.5	4.2	34	17	18	5.5	-	*	ch. 8	0.5
FRN 22 EI ⁽⁸⁾	FRNR 22 EI ⁽⁸⁾	22	9	M 6 x 1	7.7	9.4	9	6.5	39	18.2	20	8	-	*	ch. 10	0.5
FRN 32 EI ⁽⁸⁾	FRNR 32 EI ⁽⁸⁾	32	14	M 10 x 1.25	11.8	12.6	12	10.4	52	24.2	26	11	-	4	ch. 16	1
FRN 40 EI ⁽⁹⁾	FRNR 40 EI ⁽⁹⁾	40	16	M 12 x 1.5	14.6	15.5	12	11.4	60	29.4	31	11	-	8	ch. 18	1

*) screwdriver slot

Type		Bearing rating (N)				Limit loads (N)		Torque wrench ⁽²⁾ settings (Nm)	Weight (g)
		Dynamic		Static		radial F _r	axial F _a		
		C _{wr} ⁽⁴⁾	C _{wa} ⁽⁴⁾	radial C _{or}	axial C _{oa}				
FRN 19 EI	FRNR 19 EI	1 800	600	1 720	1 300	490	270	1.8	35
FRN 22 EI	FRNR 22 EI	3 280	800	3 750	1 670	590	290	3	53
FRN 32 EI	FRNR 32 EI	5 600	2 100	7 200	5 100	2 030	950	20	160
FRN 40 EI	FRNR 40 EI	12 300	2 600	17 000	6 700	2 800	1 350	26	290

1) Housing bore tolerance: H7

2) The torque wrench settings are given for non-lubricated threads; for lubricated threads, multiply figure by 0.8

3) On request, the guide rollers can be supplied in AISI 440 stainless steel (suffix **NX**)

4) C_w basic load for 100 km

5) The guide rollers are complete with self-locking washers and hexagonal nut (DIN 439B) for fitting

6) Pressure angle α for load calculation: 40°

7) Standard Viton seals to fit temperature up to 120°C

8) Lubrication hole only on the head side

9) Lubrication hole also on the stud side

Guide Rollers **FRLK..FRLR**

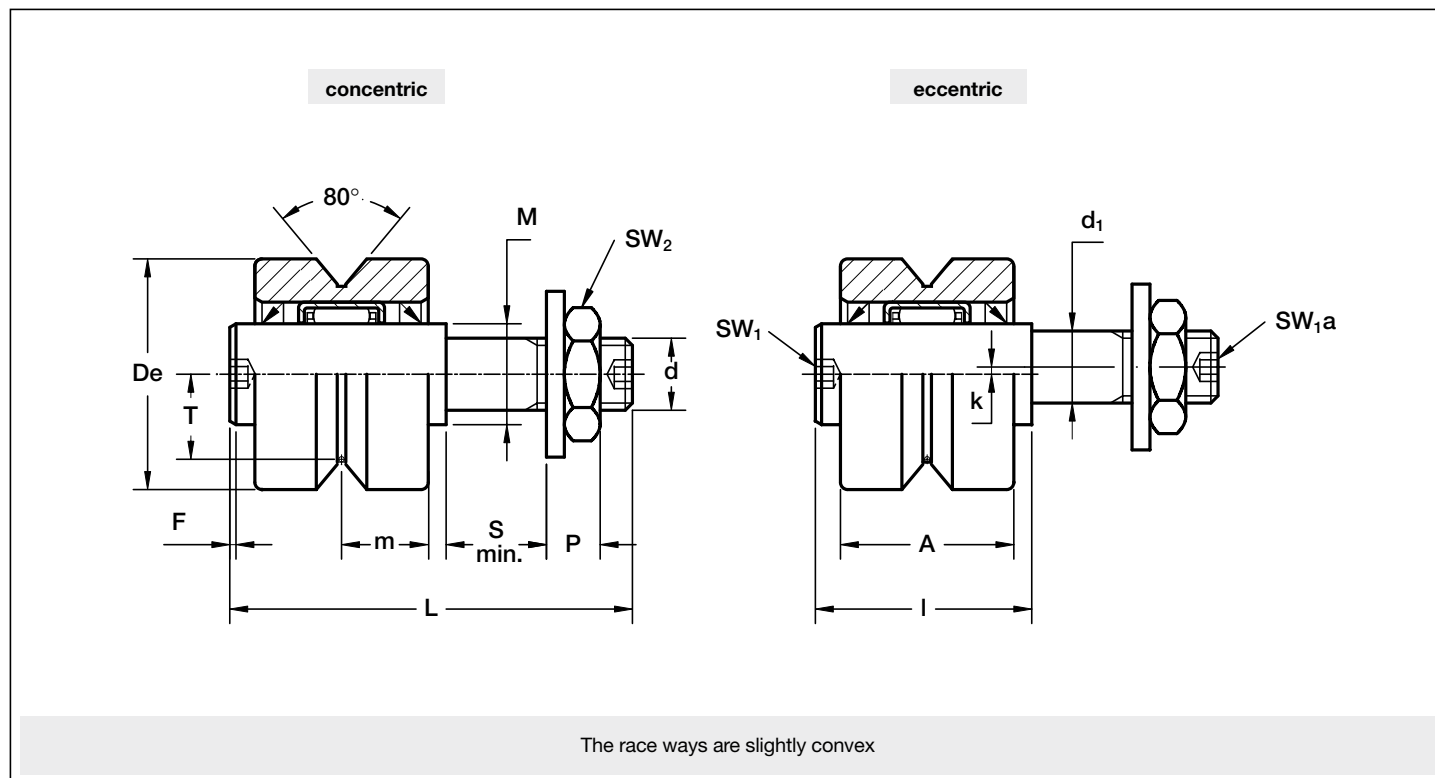
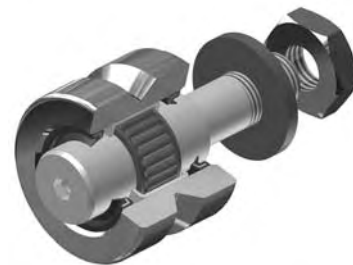

Type		Dimensions (mm)														
concentric	eccentric	De	d ₁ ⁽¹⁾	d	T	m	S min.	P	L	A	I	F	M	SW ₁	SW ₂	k
FRLK 19	FRLR 19	19	5	M 5 x 0.8	7	8.3	6.5	3.9	38.6	16.6	22.6	1	7	2.5	8	0.5
FRLK 22	FRLR 22	22	6	M 6 x 1	7.7	8.9	9	4.7	42.8	17.8	23.8	1	10	3	10	0.5
FRLK 32	FRLR 32	32	10	M 10 x 1.25	11.8	12.1	12	7.5	56.2	24.2	30.2	1	14	4	17	1
FRLK 40	FRLR 40	40	12	M 12 x 1.5	14.6	14.7	12	9	64.7	29.4	35.7	2	20	4	19	1
FRLK 52	FRLR 52	52	16	M 16 x 1.5	19.1	18.8	15	12	77.6	37.6	44.6	2	25	5	24	1.5
FRLK 62	FRLR 62	62	20	M 20 x 1.5	22.1	19.8	19	15	87.6	39.6	46.6	2	30	8	30	2
FRLK 72	FRLR 72	72	24	M 24 x 1.5	25.5	26	22	18	109	52	59	2	35	10	36	3

Type		Bearing rating (N)		Limit loads (N)	Torque ⁽²⁾ wrench setting (Nm)	Weight (g) ⁽³⁾
		Dynamic	Static			
		C _w ⁽⁴⁾	radial C _{or}	radial F _r		
FRLK 19	FRLR 19	1 910	930	240	1.8	42
FRLK 22	FRLR 22	2 860	1 500	410	3	60
FRLK 32	FRLR 32	5 620	2 900	1 720	20	160
FRLK 40	FRLR 40	10 600	6 400	2 610	26	300
FRLK 52	FRLR 52	17 700	10 500	5 150	64	627
FRLK 62	FRLR 62	20 500	12 400	9 610	120	967
FRLK 72	FRLR 72	35 400	22 000	13 500	220	1 714

1) Housing bore tolerance: H7

2) The torque wrench settings are given for non-lubricated threads; for lubricated threads, multiply figure by 0.8

3) Weight without fittings

4) C_w basic load for 100 km

5) The guide rollers are completed with conical spring washer and nut (DIN 439B)

6) The guide rollers are sealed on both sides

Guide Rollers **RKY..RKX**

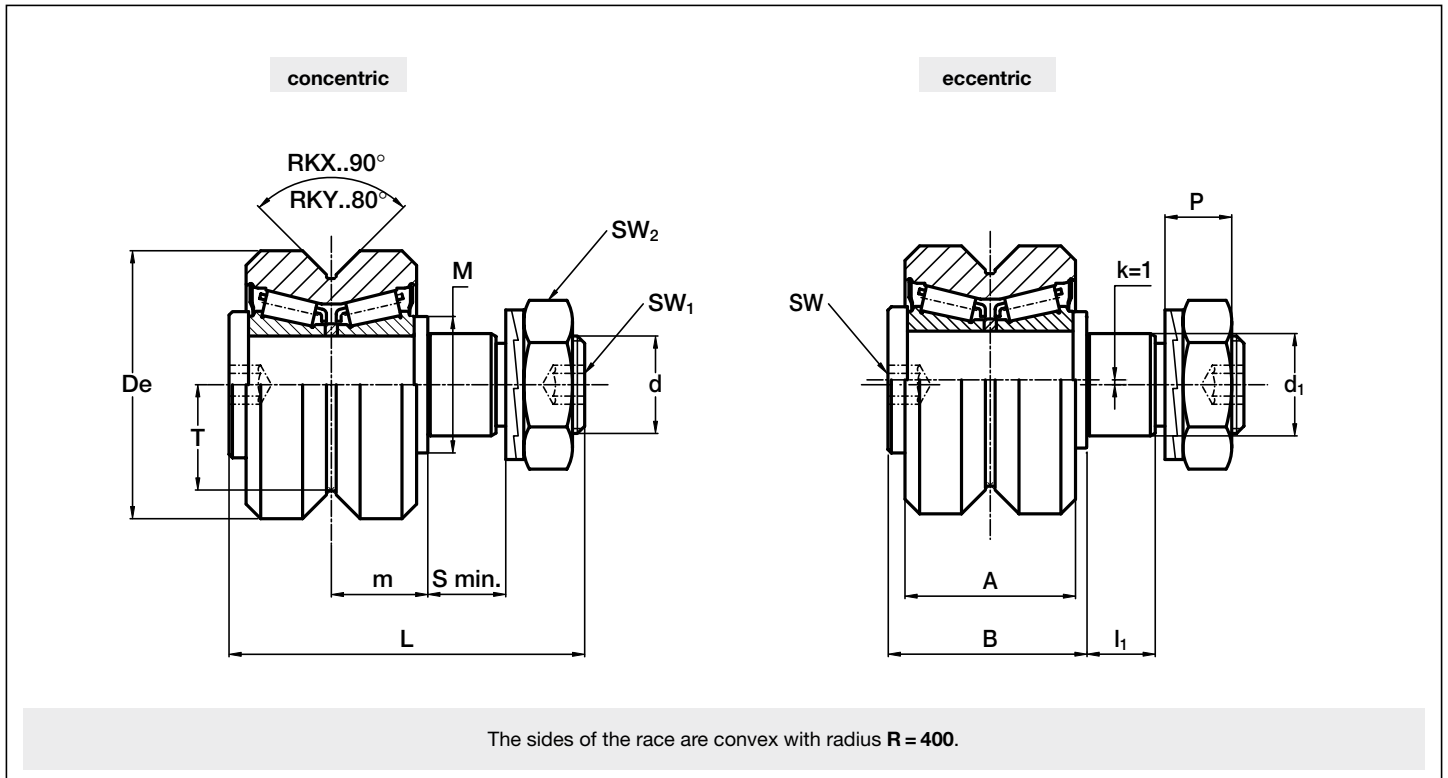

Type		Dimensions (mm)															
concentric	eccentric	De	d ₁ ⁽¹⁾	d	T	m	S min.	P	L	A	B	I ₁	M	SW ₁	SW ₂	k	
RKY 52	RKYR 52	52	21	M 20 x 1.5	19.1	19.8	15	13.4	73	35	41	14	28	8	ch. 30	1	
RKY 62	RKYR 62	62	27	M 24 x 1.5	22.1	20.8	19	15.4	83	37	44	18	35	10	ch. 36	1	
RKY 72	RKYR 72	72	36	M 30 x 1.5	25.5	27	19	21.6	100	45	55	18	44	12	ch. 46	1	
RKX 90C	RKXR 90C	90	38	M 36 x 1.5	32.5	30	24	24.6	115	53	56 ⁽⁶⁾	62	23	50	14	ch. 55	1
RKX 110C	RKXR 110C	110	42	M 36 x 1.5	39.5	34	33	24.6	135	60	63 ⁽⁶⁾	70	32	56	14	ch. 55	1

Type		Bearing rating (N)			Limit loads (N)		Life coefficients				Torque wrench settings ⁽²⁾ (Nm)	Weight (kg)
		Dynamic	Static				Pa/Pr ≤ 0.1		Pa/Pr > 0.1			
			C _w ⁽⁵⁾	radial C _{or}	axial C _{oa}	radial F _r	axial F _a	X	Y	X		
RKY 52	RKYR 52	40 750	44 000	12 400	11 900	4 250	1	4.67	0.77	6.98	80	0.6
RKY 62	RKYR 62	46 000	50 400	12 750	22 100	6 800	1	3.93	0.74	6.55	160	0.9
RKY 72	RKYR 72	64 850	72 000	18 900	31 300	10 100	1	4.67	0.77	6.98	300	1.6
RKX 90C	RKXR 90C	113 400	136 000	37 800	43 700	12 600	1	3	0.8	4.96	450	2.8
RKX 110C	RKXR 110C	177 500	195 000	50 000	55 600	17 900	1	4.26	0.72	7.1	450	4.9

- Housing bore tolerance: H7
- The torque wrench settings are given for non-lubricated threads; for lubricated threads, multiply figure by 0.8
- Standard seals: material NBR, RS type
- On request, the guide rollers can be supplied in AISI 440 stainless steel (suffix **NX**) and with Viton seals for operating temperatures up to 120 °C (suffix **V**, up to dimension RKX 90 C included)
- C_w basic load for 100 km
- Dimensions relating to the stainless-steel rollers (suffix **NX**)
- The guide rollers are complete with self-locking washers and hexagonal nut (DIN 439B) for fitting
- Pressure angle α for load calculation: guide rollers RKY 40° - guide rollers RKX 45°

Guide Wheels **FKY..FKX**

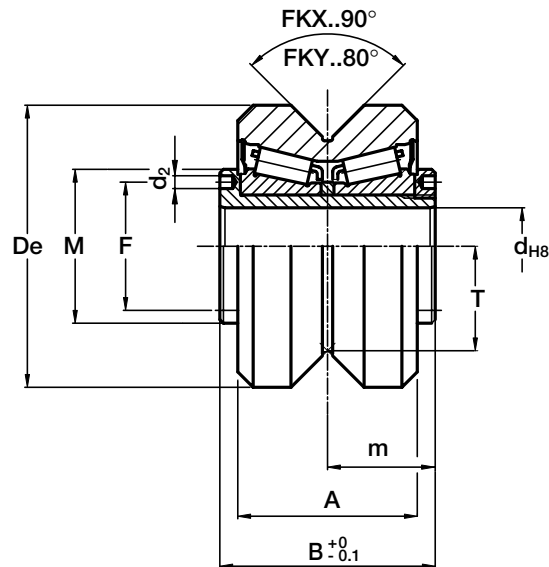

The sides of the race are convex.

Type	Dimensions (mm)									Weight (kg)
	De	d	T	m	A	B	F	d ₂	M	
FKY 52C	52	15	19.1	21	35	42	25	2.5	30	0.5
FKY 62C	62	20	22.1	22.5	37	45	29	3	35	0.6
FKY 72C	72	25	25.5	28	45	56	37	4	44	1.2
FKX 90C	90	28	32.5	32	53	56 ⁽²⁾⁻⁻⁻	64	4	49	2.3
FKX 110C	110	35	39.5	36	60	63 ⁽²⁾⁻⁻⁻	72	4	59	3.9

Type	Bearing rating (N)			Life coefficients			
	Dynamic	Static		Pa/Pr ≤ 0.1		Pa/Pr > 0.1	
	C _w ⁽³⁾	radial C _{or}	axial C _{oa}	X	Y	X	Y
FKY 52C	40 750	44 000	12 400	1	4.67	0.77	6.98
FKY 62C	46 000	50 400	12 750	1	3.93	0.74	6.55
FKY 72C	64 850	72 000	18 900	1	4.67	0.77	6.98
FKX 90C	113 400	136 000	37 800	1	3	0.8	4.96
FKX 110C	177 550	195 000	50 000	1	4.26	0.72	7.1

- 1) On request, the guide rollers can be supplied in AISI 440 stainless steel (suffix **NX**) and with Viton seals for operating temperatures up to 120 °C (suffix **V**, up to dimension FKX 90 C included)
- 2) Dimensions relating to the stainless-steel rollers (suffix **NX**)
- 3) C_w basic load for 100 km
- 4) To prevent rotation between roller and shaft a pin can be fitted in one of the holes "d₂" positioned in the side flange
- 5) Pressure angle α for load calculation: guide rollers FKY 40° - guide rollers FKX 45°
- 6) Standard seals: material NBR, RS type

Lubricator **LUBY** **NEW**

for FS guide rollers

up to size 40

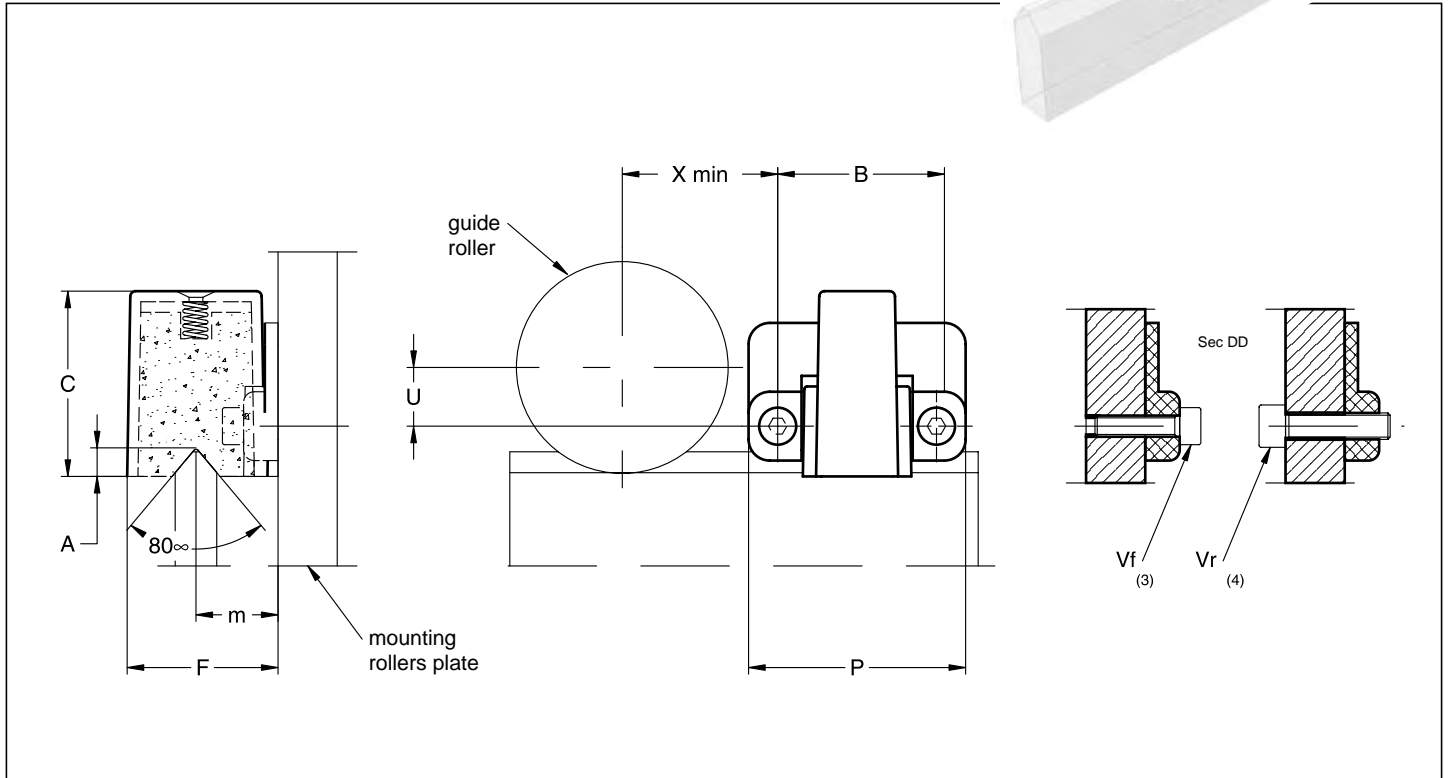
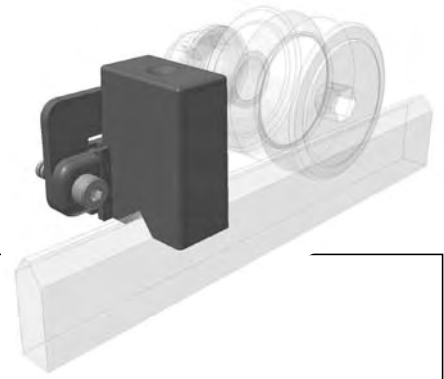

Type	Dimensions (mm)										Weight (g)	Suggested combinations
	X	U	B	F	m	A	C	P	Vf	Vr		
LUBY 19	15	1.5	25	15.6	8.8	2.5	19	32.5	M3x12	M4	10	FR... 19...
LUBY 22	16.5	3	25	16.8	9.4	3.3	22	32.5	M3x12	M4	10	FR... 22...
LUBY 32	21.5	8	25	23.2	12.6	4.2	30	32.5	M3x12	M4	15	FR... 32...
LUBX 40	27.5	10.5	30	28.5	15.5	5.4	35	41	M4x12	M5	30	FR... 40...

1) The lubricator is supplied with the felt already lubricated. The lubricant has a mineral oil base

2) At the mounting, insert the screws inside the rollers plate, without tighten them, adjust the height of the plastic part in order to put it in contact with the raceways and then block it

3) The screws Vf for the frontal mounting are included in the packaging. Arrange two thread holes for dimension Vf in the mounting rollers plate

4) The screws for the mounting on the nut side of the roller are not included in the packaging. Arrange on the mounting rollers plate the holes in order to insert te screws Vr

Lubricator **LUBY, LUBX**

for FS guide rollers
size 52 and higher

NEW

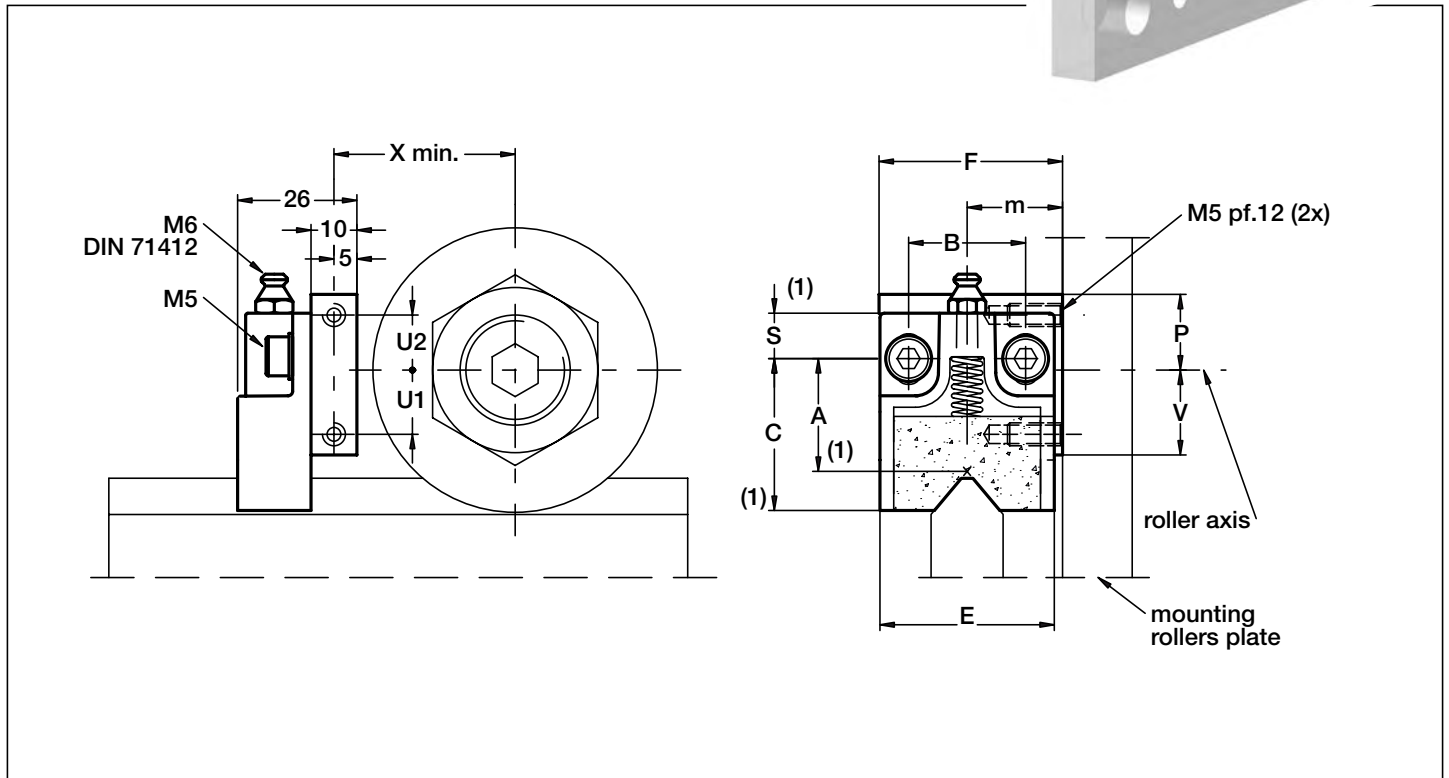
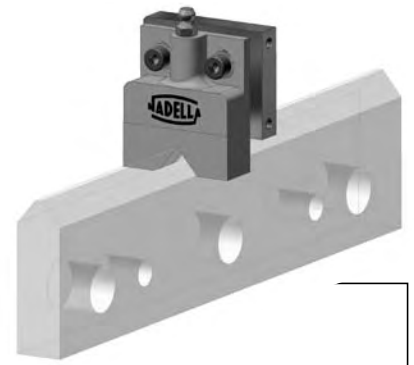

Type	Dimensions (mm)												Weight (g)	Suggested combinations
	X	U1	U2	F	m	B	S	C	A	E	V	P		
LUBY 52	33.5	12	14	40	19.8	25.5	10	34	24.5	38	16.5	18.5	65	RKY 52 RKYR 52 FKY 52 FR 52 EI FRR 52 EI
LUBY 62	38.5	14	12	40	20.8	25.5	10	34	24.5	38	18.5	16.5	65	RKY 62 RKYR 62 FKY 62 FR 62 EI FRR 62 EI
LUBY 72	43.5	19	11	50	27	25.5	10	40	29	44	24	16	85	RKY 72 RKYR 72 FKY 72
LUBX 90	52.5	21	9	60	30	30	16.5	45.5	33.5	58	31	19	140	RKX 90C RKXR 90C FKX 90C
LUBX 110	62.5	30	0	63	34	30	16.5	45.5	33.5	58	40	10	140	RKX 110C RKXR 110C FKX 110C

1) The dimension of the plastic part refers to the centre of the regulation slot. The regulation slot allows a translation of +/- 3 mm

2) The lubricator is supplied with the felt already lubricated. The lubricant has a mineral oil base

3) During the mounting fix the aluminium support to the rollers plate, adjust the height of the plastic part in order to put it in contact with the raceways and than block it in that position with the M5 screws

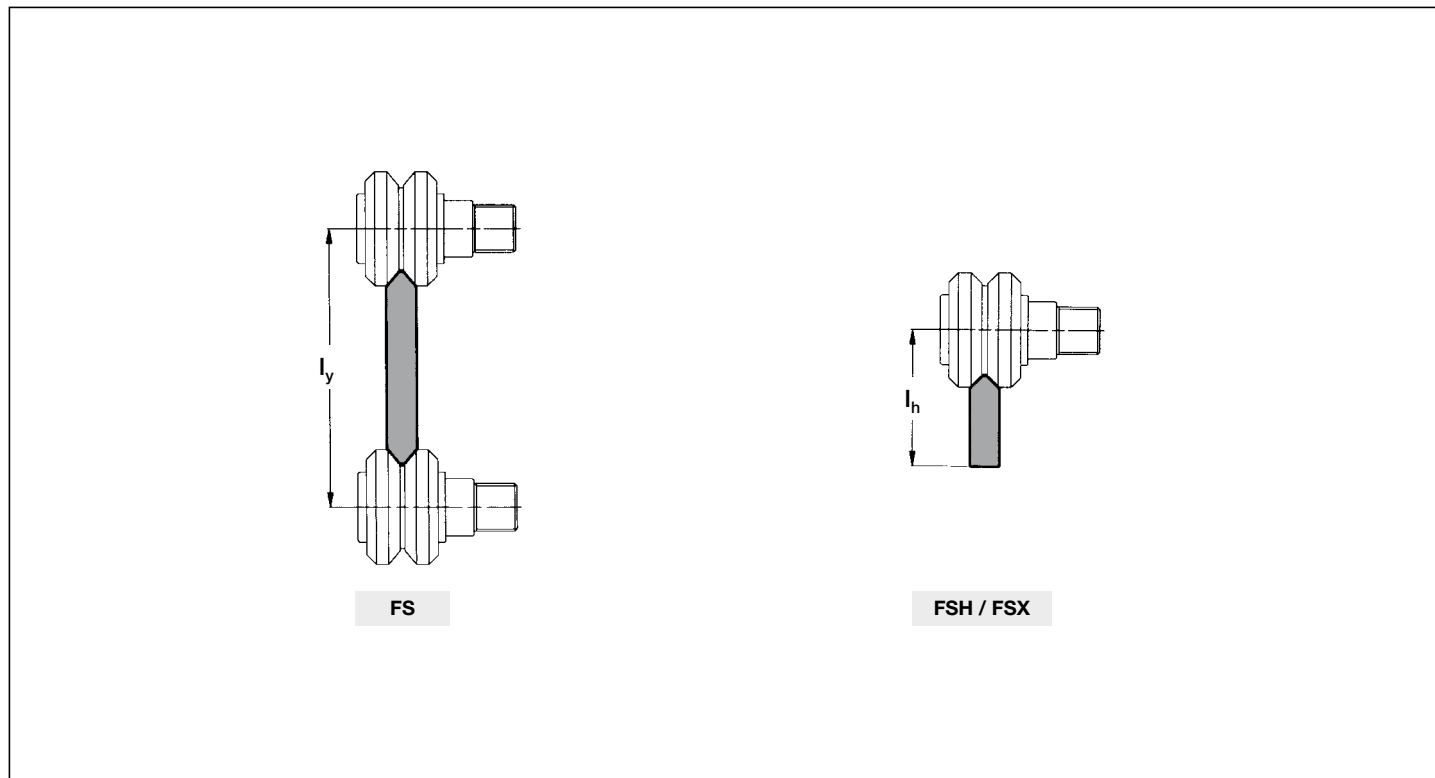

Guide Rollers FR...EI, FRN...EI, RKY, RKX, FKY, FRL, FRLK

	ly (mm)	Guide roller size						
		19...	22...	32...	40...	52...	62...	72...
FS..M	FS 19 M	35	36.4					
	FS 22 M	41.9	43.3					
	FS 32 M			66.5				
	FS 35 M			71.5	*77			
	FS 40 M				92.8			
	FS 47 M					116.8		
	FS 52 M					128	*134	
	FS 62 M					143	149	
	FS 72 M						*167.2	174

	lh (mm)	Guide roller size									
		19...	22...	32...	40...	52...	62...	72...	90...	110...	
FSH..M, FSX..M	FSH 19 M	26	26.7								
	FSH 22 M	*29.9	30.6								
	FSH 32 M			40.7							
	FSH 40 M			*48	50.9						
	FSH 52 M				*54	58.5					
	FSH 62 M					*68.5	71.5				
	FSH 72 M						*81.6	85			
	FSX 90 M								94.3	101.3	

	ly (mm)	Guide roller size						
		19...	22...	32...	40...	52...	62...	72...
FS..MT	FS 19 MT	36.2	37.6					
	FS 22 MT		44.2					
	FS 32 MT			67.4				
	FS 35 MT			72.4	*78			
	FS 40 MT				93.7			
	FS 47 MT					118.3		
	FS 52 MT					129.5	*135.5	
	FS 62 MT					144.2	150.2	
	FS 72 MT						*168.8	175.6

	lh (mm)	Guide roller size									
		19...	22...	32...	40...	52...	62...	72...	90...	110...	
FSH..MT, FSX..MT	FSH 22 MT	30.9	31.6								
	FSH 32 MT			41.7							
	FSH 40 MT			*49	51.8						
	FSH 52 MT				*55.4	59.9					
	FSH 62 MT					*69.9	72.9				
	FSH 72 MT						*83	86.4			
	FSX 90 MT								95.3	102.3	

* possible combination

Mounting Examples

- Handling device for a plastic moulding machine.

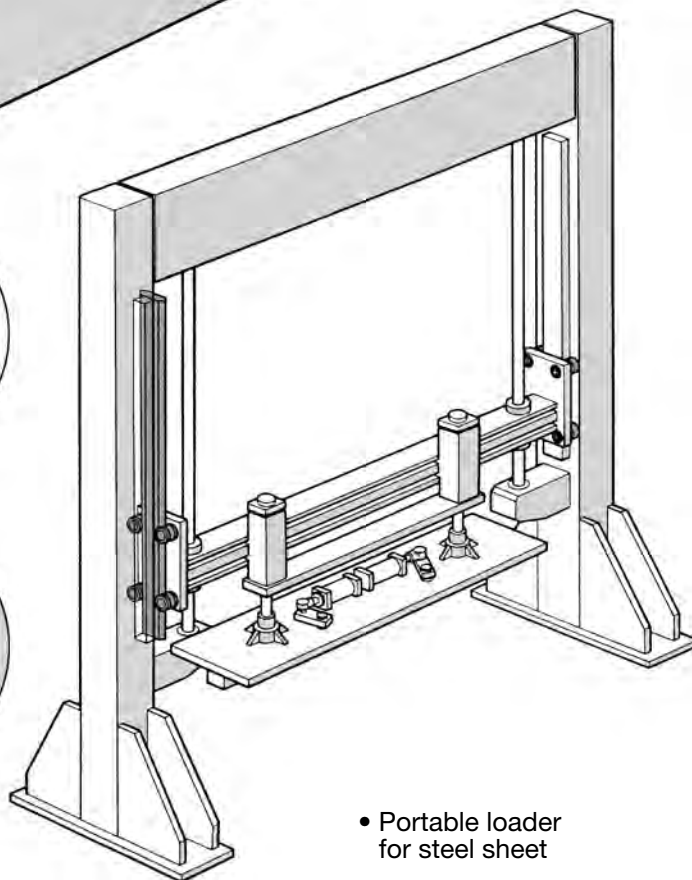
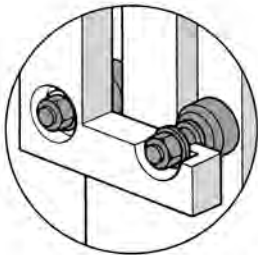
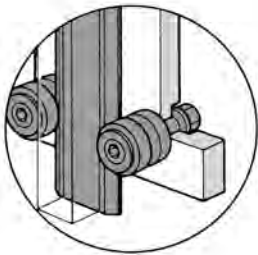
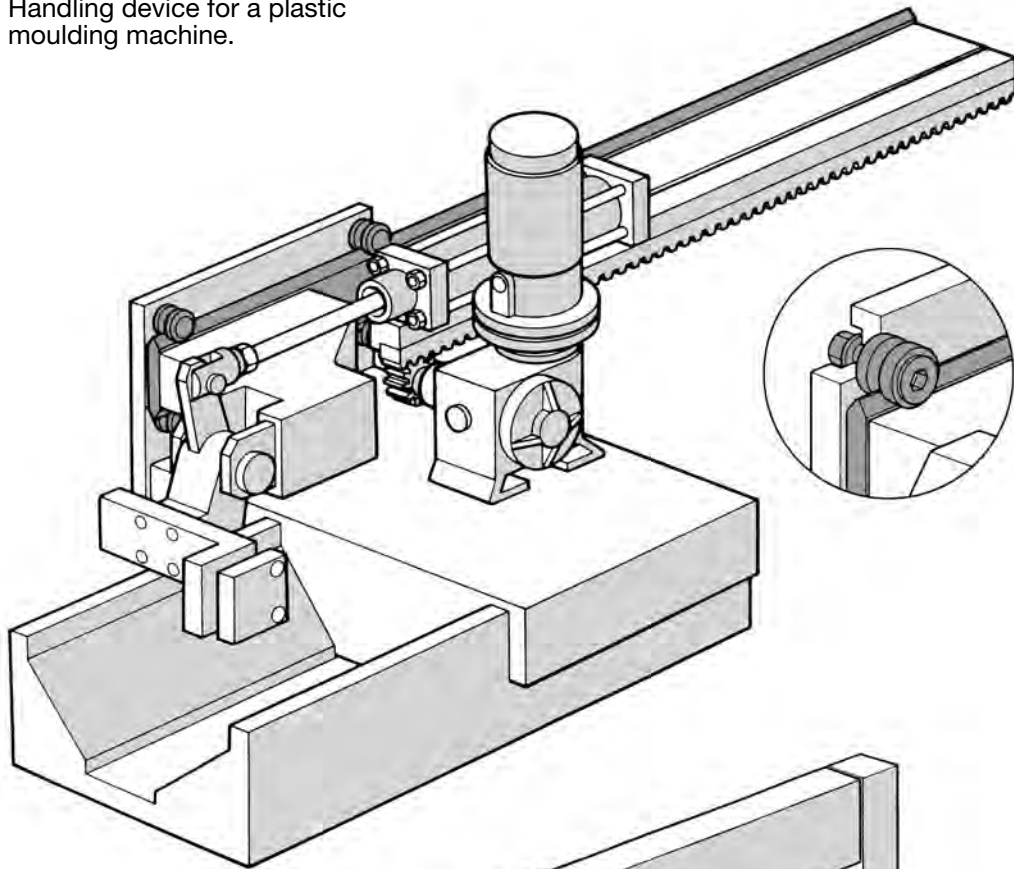

- Portable loader for steel sheet

FSR System NEW

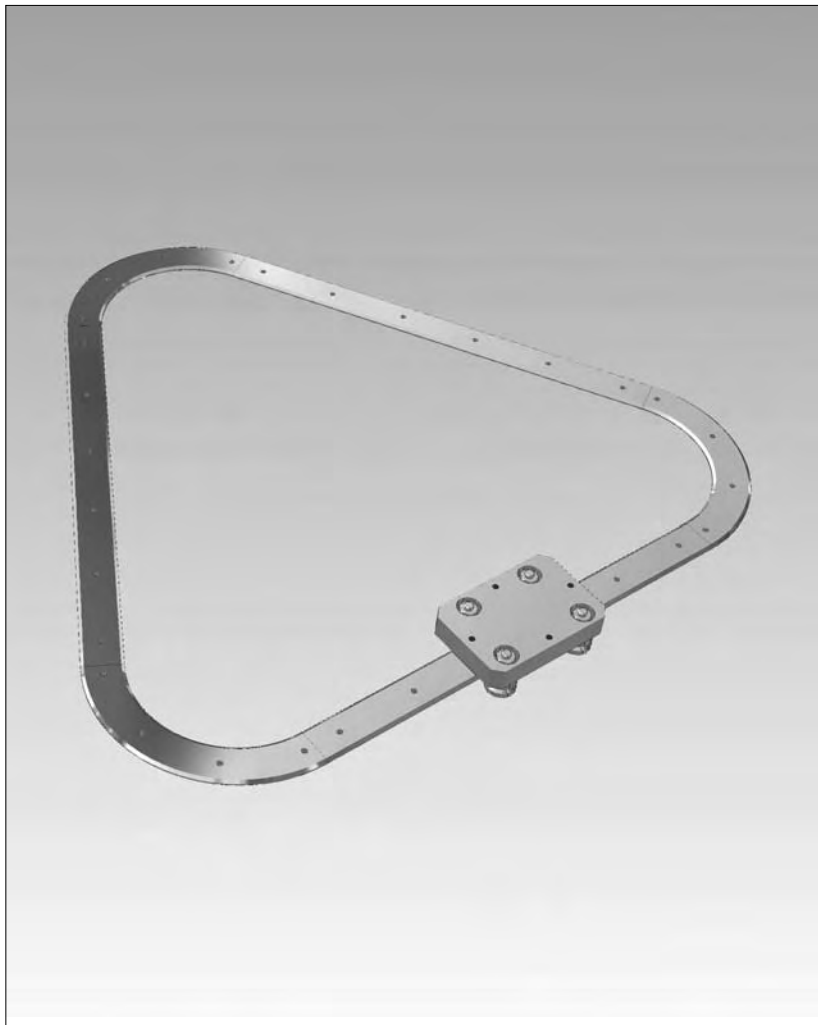

NADELLA

Circular systems

Nadella proposes several circular rails based on the FS family profiles. The rails can be used as entire circumference or single sectors or joined together with straight piece or rails in order to obtain oval circuit or ring circuits.

The rails are in steel, induction hardened on the raceways, with the same section dimensions of straight FS..M rails. In the circuits the rails are joined together with alignment blocks that allow an easy mounting.

All the pieces of the circuit are supplied appropriately marked in order to avoid mistake during the joining.

For the protection against corrosion Nadella proposes a nickel plating surface treatment (option NW) for both straight and circular pieces.

In addition to the standard dimensions in the table it is possible to realise rings with different sections or rays in order to satisfy specific demands.

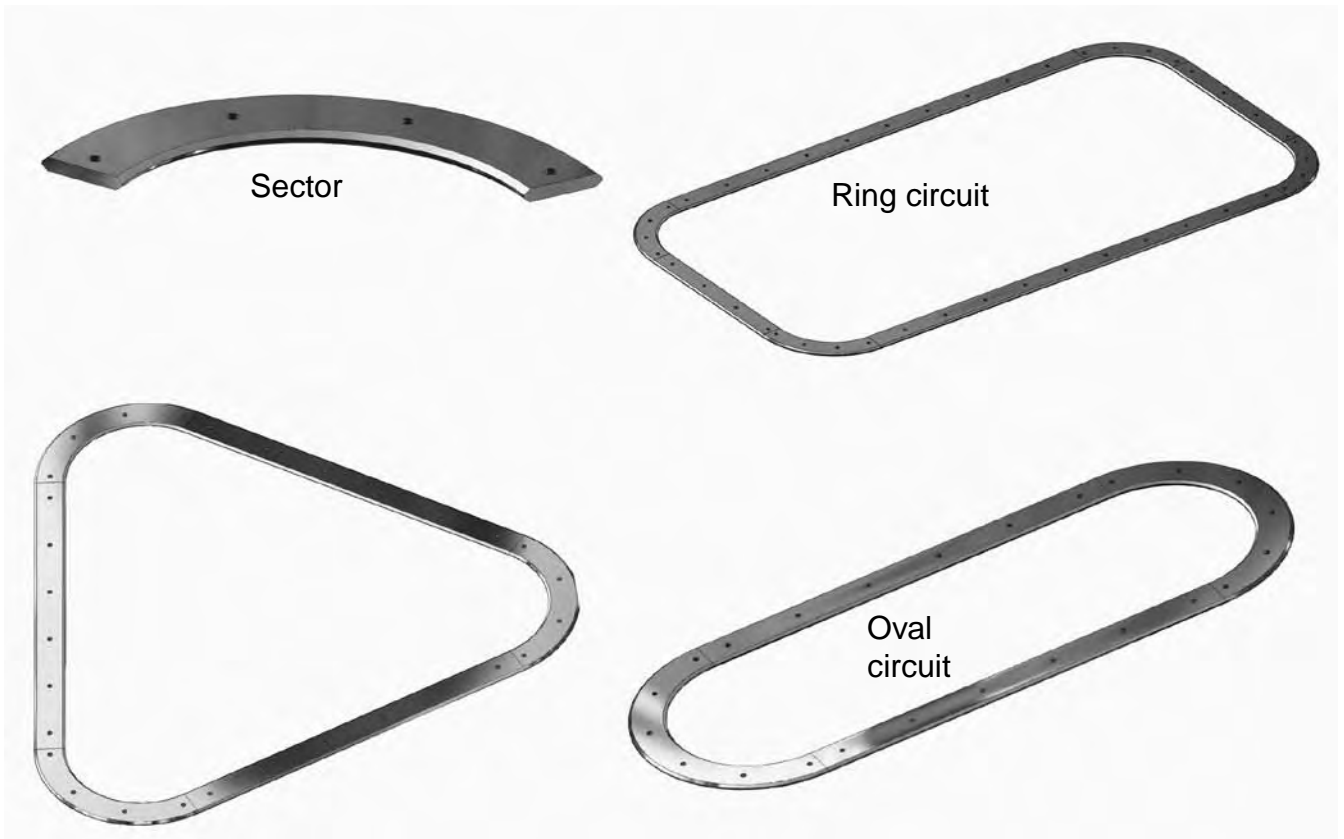

Circular rails **FSR..M** **NEW**

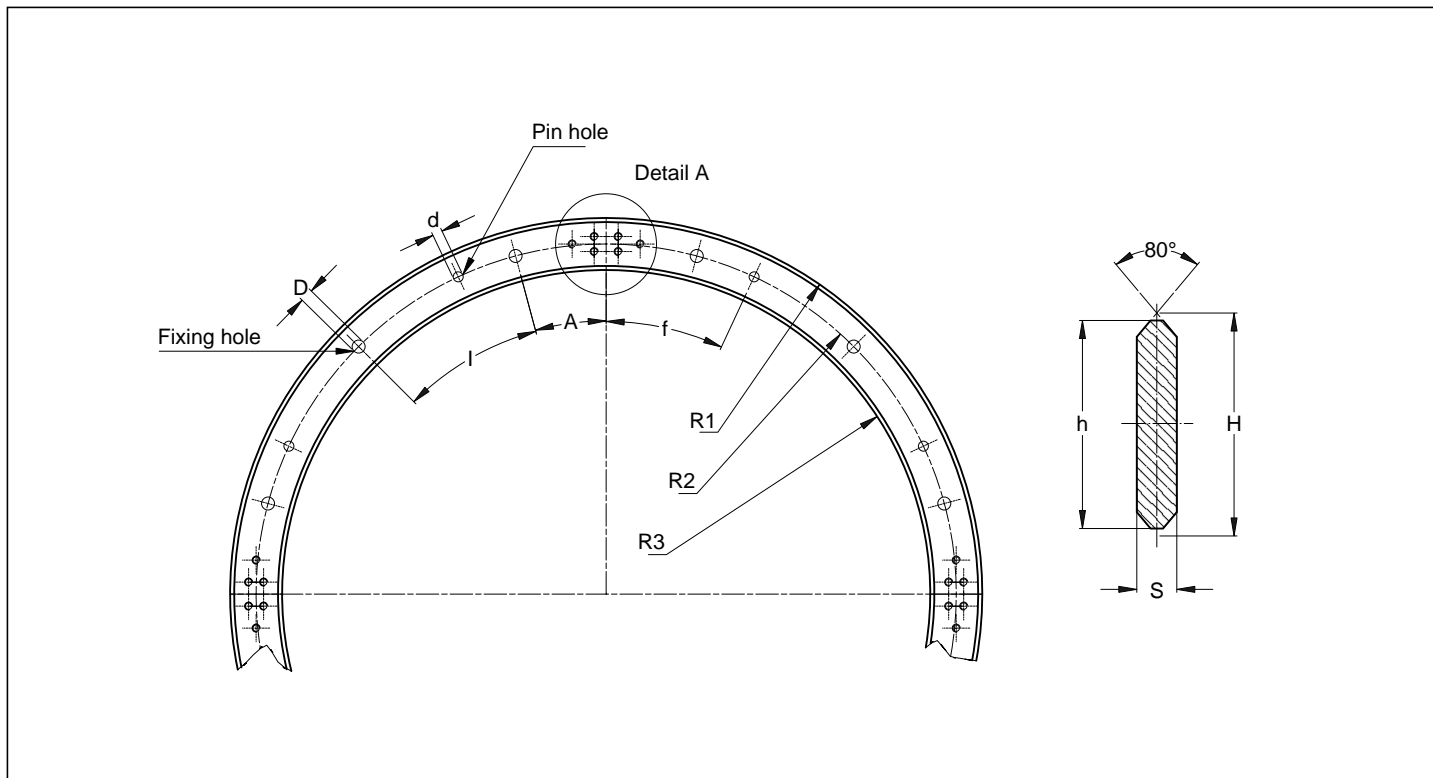

Type	A	l	f	d H7	D	R1	R2	R3	n° fixing holes/360°	n° pin holes/360°	h	H	S
FSR22M-075	22,5°	45°	45°	5	6,5	88	75	62	8	4	26	27,86	5
FSR22M-125	15°	30°	25°	5	6,5	138	125	112	12	8	26	27,86	5
FSR22M-175	15°	30°	25°	5	6,5	188	175	162	12	8	26	27,86	5
FSR35M-225	11,25°	22,5°	7,5°	8	9	248	225	202	16	8	46	47,86	8
FSR35M-300	11,25°	22,5°	7,5°	8	9	323	300	277	16	8	46	47,86	8
FSR47M-400	9°	18°	18°	10	11,5	438	400	362	20	8	76	78,58	10
FSR47M-500	9°	18°	18°	10	11,5	538	500	462	20	8	76	78,58	10

Rails finishing

- steel
- induction hardened on the raceways

Hole layout

- holes according to catalogue (**SB**)
- finishes to drawing (**NZ**)

Optional features

- nickel plating (**NW**)

Example of standard designation: **FSR35M-225-180**

Circular rail sector FSR35M ray 225 mm,
sector angle 180°

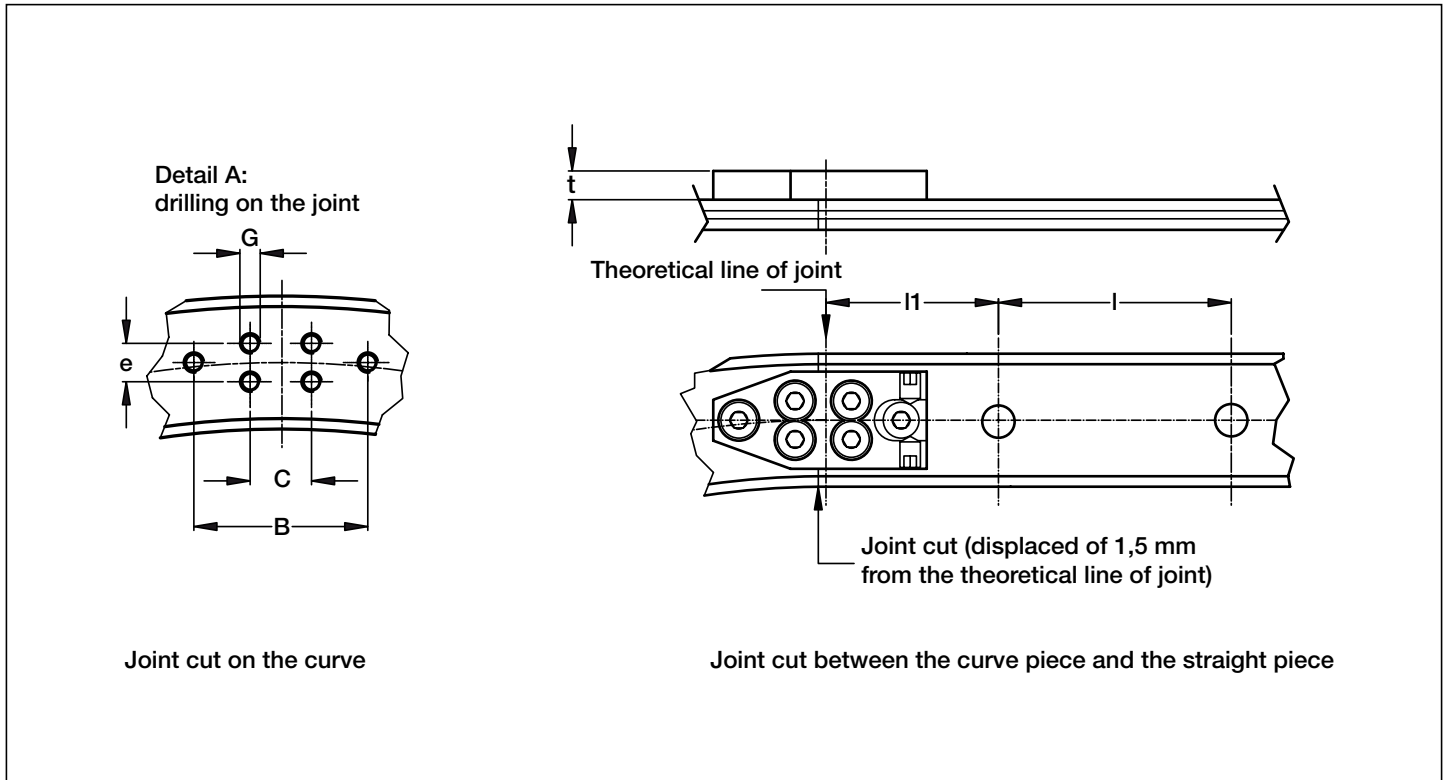

Type	Dimensions (mm)							Suggested combination
	C	B	e	G	t	l1	l	
FSR22M-075	12	34	7,5	M4	5,8	50	90	FR22EI FRN22EI
FSR22M-125								
FSR22M-175								
FSR35M-225	18	38	20	M6	6	50	90	FR32EI FRN32EI FR40EI FRN40EI
FSR35M-300								
FSR47M-400	18	58	43	M6	9	50	90	FR40EI FRN40EI FR52EI RKY52EI
FSR47M-500								

The alignment block allows an easy mounting of the joint.

The joint cut is displaced of 1,5 mm from the theoretical line of joint.

GP System



NADELLA

Guide rails GP..MC

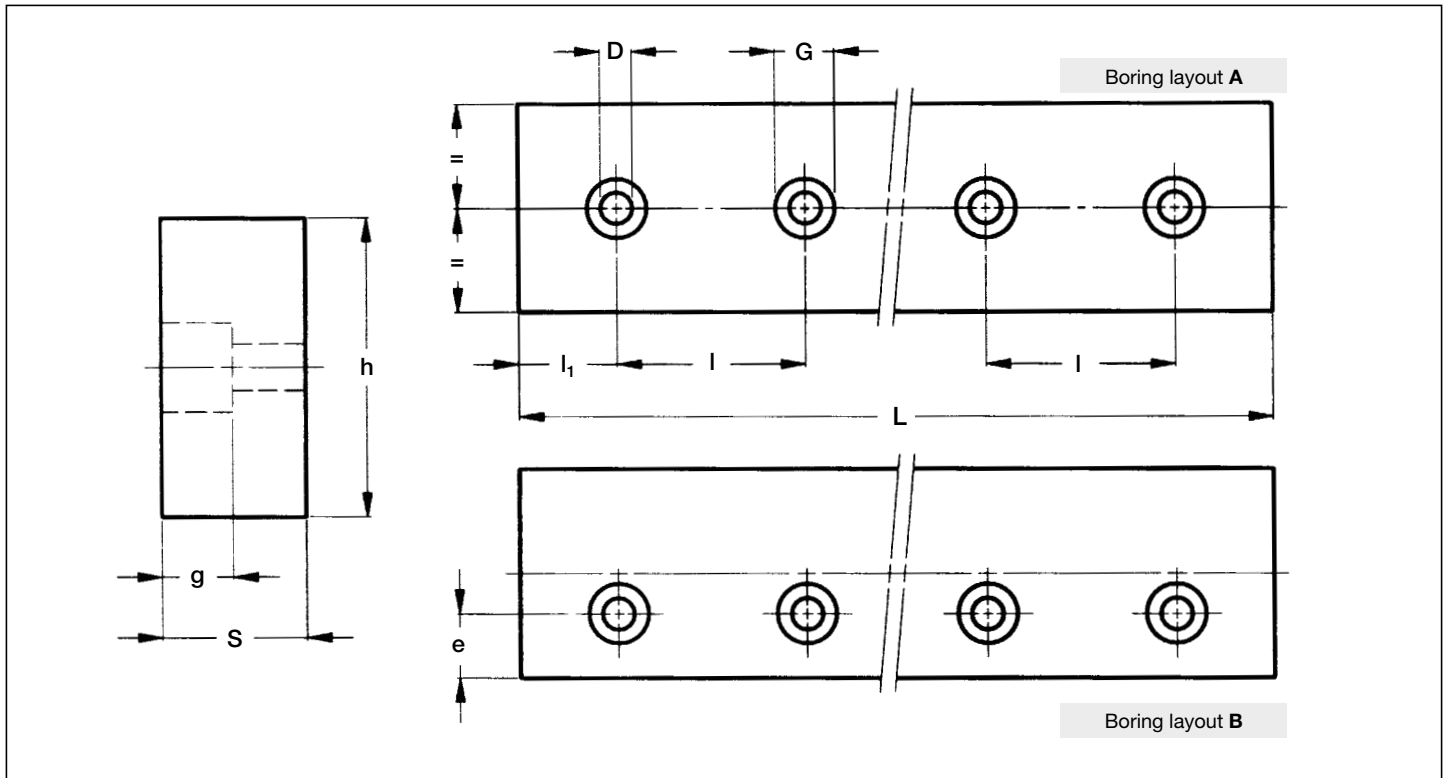

Type	Dimensions (mm)								Weight ⁽²⁾ (kg/m)
	h ± 0.2	S ± 0.2	D	G	g	e	l	l ₁	
GP 2626 MC	26	26	9	15	9	(3)	120	50	5.3
GP 3232 MC	32	32	9	15	9	(3)	150	60	8.1
GP 3617 MC	36	17	6.5	11	6.8	12.5	120	50	4.8
GP 4321 MC	43	21	9	15	9	11.5	150	60	7
GP 6222 MC	62	22	9	15	9	21	150	60	10.7
GP 7232 MC	72	32	13.5	20	13	24	180	70	18.1
GP 8222 MC	82	22	13.5	20	13	20	180	70	14.2

Max length of single guide element L = 5 800 mm ⁽¹⁾

1) Longer rails are supplied in sections with ground butt joints

2) Weight without holes

3) For boring layout A only

Rails finishing

- material: C60 or CK45
- induction hardened on every side
- surface finished by a rough grinding (MC)

Hole layout

- holes according to catalogue (A or B)
- finishes to drawing (NZ)
- without holes (NF)

Optional features

- ground one end (R)
- ground both ends (RR)
- chemical nickel plating (NW)

Example of standard designation: **GP 6222 MC/4300/B**

See page 15 for standard codification

Guide Rails GP..M

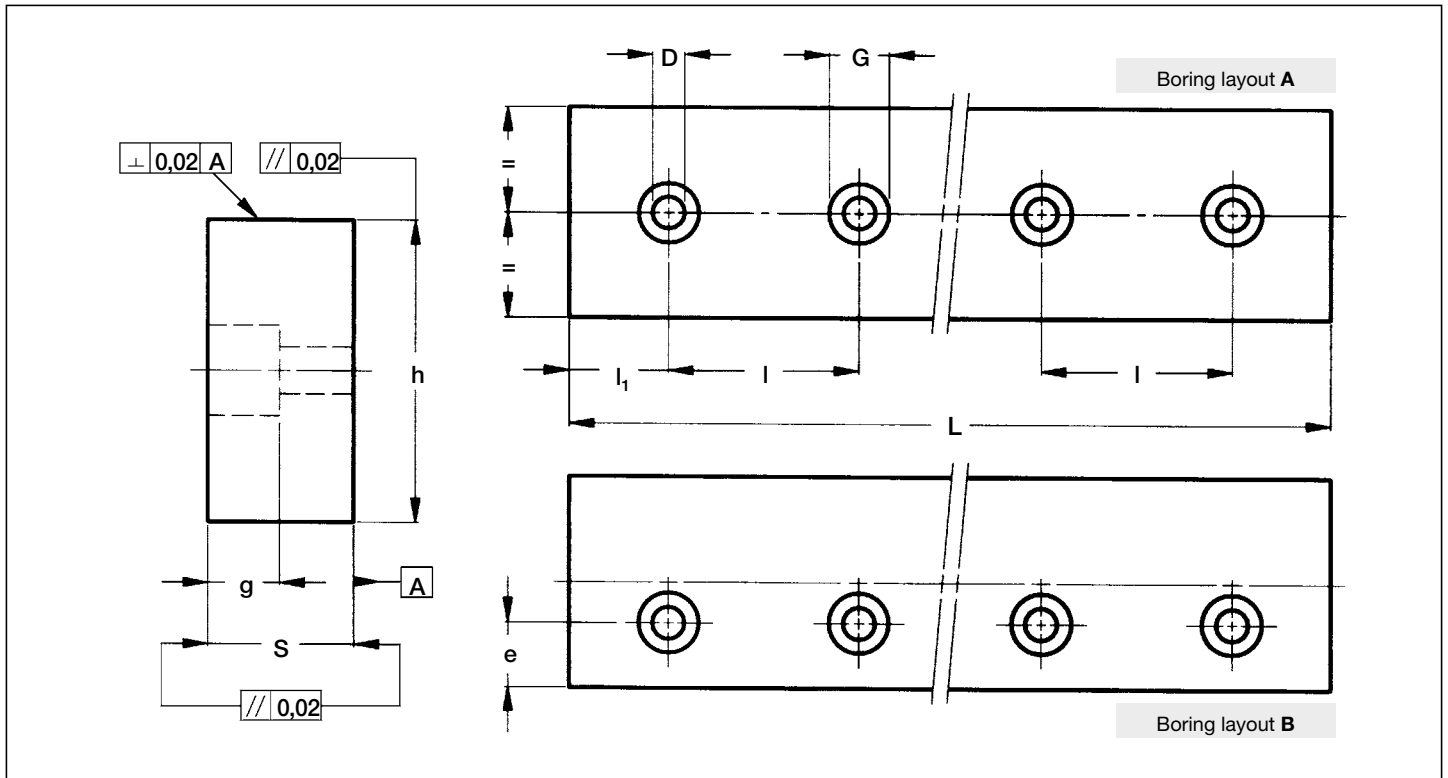

Type	Dimensions (mm)								Weight ⁽²⁾ (kg/m)
	h ± 0.05	S ± 0.05	D	G	g	e	l	l ₁	
GP 2525 M	25	25	9	15	8.5	(3)	120	50	4.9
GP 3131 M	31	31	9	15	8.5	(3)	150	60	7.5
GP 3516 M	35	16	6.5	11	6.8	12	120	50	4.4
GP 4220 M	42	20	9	15	9	11	150	60	6.5
GP 6121 M	61	21	9	15	9	20.5	150	60	10
GP 7131 M	71	31	13.5	20	12.5	23.5	180	70	17.3
GP 8121 M	81	21	13.5	20	13	19.5	180	70	13.4

max length of single guide element L = 4 020 mm ⁽¹⁾

1) longer rails are supplied in sections with ground butt joints (max. length with treatment NW on request)

2) Weight without holes - 3) Only available according to figure A

Rails finishing

- material: C60 or CK45
- induction hardened and ground tracks on every side (**M**);

Hole layout

- holes according to catalogue (**A** or **B**)
- finishes to drawing (**NZ**)
- without holes (**NF**)

Optional features

- ground one end (**R**)
- ground both ends (**RR**)
- chemical Nickel-plating (**NW**)

Example of standard designation: **GP 6121 M/2070/B**

See page 15 for standard codification

Guide Rollers **PK**

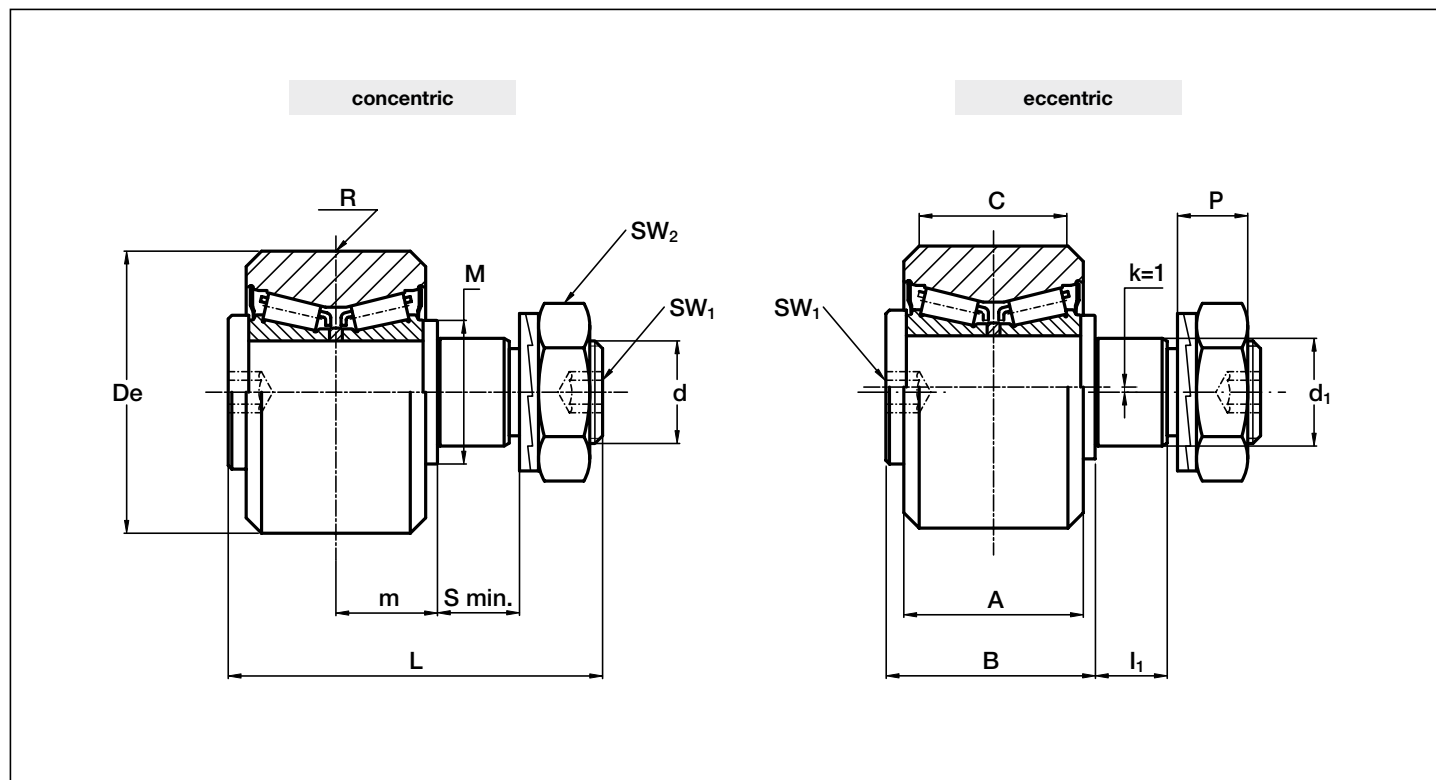

Type		Dimensions (mm)															
concentric	eccentric	De	d ₁ ⁽¹⁾	d	m	S min.	P	L	A	B	C	R	I ₁	M	SW ₁	SW ₂	k
PK 52C	PKR 52C	52	21	M 20 x 1.5	19.8	15	13.4	73	35	41	29	800	14	28	8	ch. 30	1
PK 62C	PKR 62C	62	27	M 24 x 1.5	20.8	19	15.4	83	37	44	29	800	18	35	10	ch. 36	1
PK 72C	PKR 72C	72	36	M 30 x 1.5	27	19	21.6	100	45	55	33	1 200	18	44	12	ch. 46	1
PK 90C	PKR 90C	90	38	M 36 x 1.5	30	24	24.6	115	53	62	45	1 200	23	50	14	ch. 55	1
PK 110C	PKR 110C	110	42	M 36 x 1.5	34	33	24.6	135	56 ⁽⁵⁾ 60	70	48	1 200	32	56	14	ch. 55	1

Type		Bearing rating (N)		Limit loads (N)	Torque ⁽²⁾ wrench setting (Nm)	Weight (Kg)
		Dynamic	Static			
		C _w ⁽⁶⁾	C _o			
PK 52C	PKR 52C	42 100	44 000	11 900	80	0.6
PK 62C	PKR 62C	47 750	50 400	22 100	160	0.9
PK 72C	PKR 72C	67 450	72 000	31 300	300	1.6
PK 90C	PKR 90C	118 000	136 000	43 700	450	2.8
PK 110C	PKR 110C	185 000	195 000	55 600	450	4.9

1) Housing bore tolerance: H7

2) The torque wrench settings are given for non-lubricated threads; for lubricated threads, multiply figure by 0.8

3) Standard seals: material NBR, RS type

4) On request, the guide rollers can be supplied in AISI 440 stainless steel (suffix **NX**) and with Viton seals for operating temperatures up to 120 °C (suffix **V**, up to dimension PK 90 C included)

5) Dimensions relating to the stainless-steel rollers (suffix **NX**)

6) C_w basic load for 100 km

7) The guide rollers are complete with self-locking washers and hexagonal nut for fitting

Guide Wheels **FK**

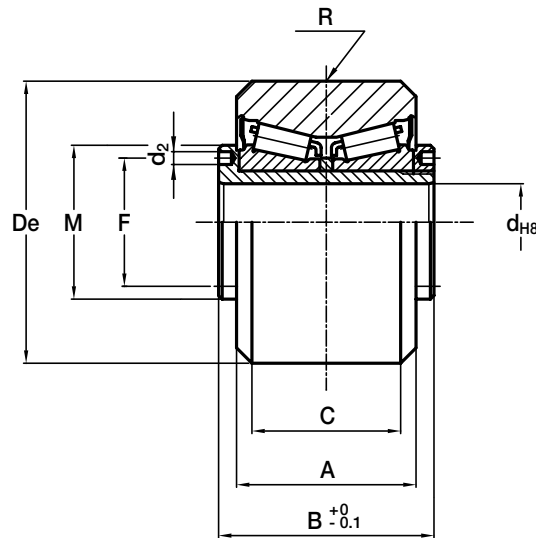

Type	Dimensions (mm)								
	De	d	A	B	C	R	F	d ₂	M
FK 52C	52	15	35	42	29	800	25	2.5	30
FK 62C	62	20	37	45	29	800	29	3	35
FK 72C	72	25	45	56	33	1 200	37	4	44
FK 90C	90	28	53	56 ⁽³⁾ 64	45	1 200	42	4	49
FK 110C	110	35	60	63 ⁽³⁾ 72	48	1 200	52	4	59

Type	Bearing rating (N)		Weight (kg)
	Dynamic	Static	
	C _w ⁽⁴⁾	radial C ₀	
FK 52C	42 100	44 000	0.5
FK 62C	47 750	50 400	0.6
FK 72C	67 450	72 000	1.2
FK 90C	118 000	136 000	2.3
FK 110C	185 000	195 200	3.9

- 1) Standard seals: material NBR, RS type
- 2) On request, the guide rollers can be supplied in AISI 440 stainless steel (suffix **NX**) and with Viton seals for operating temperatures up to 120 °C (suffix **V**, up to dimension FK 90 C included)
- 3) Dimensions relating to the stainless-steel rollers (suffix **NX**)
- 4) C_w basic load for 100 km
- 5) To prevent rotation between roller and shaft a pin can be fitted in one of the holes “d₂” positioned in the side flange

Guide Rollers GC

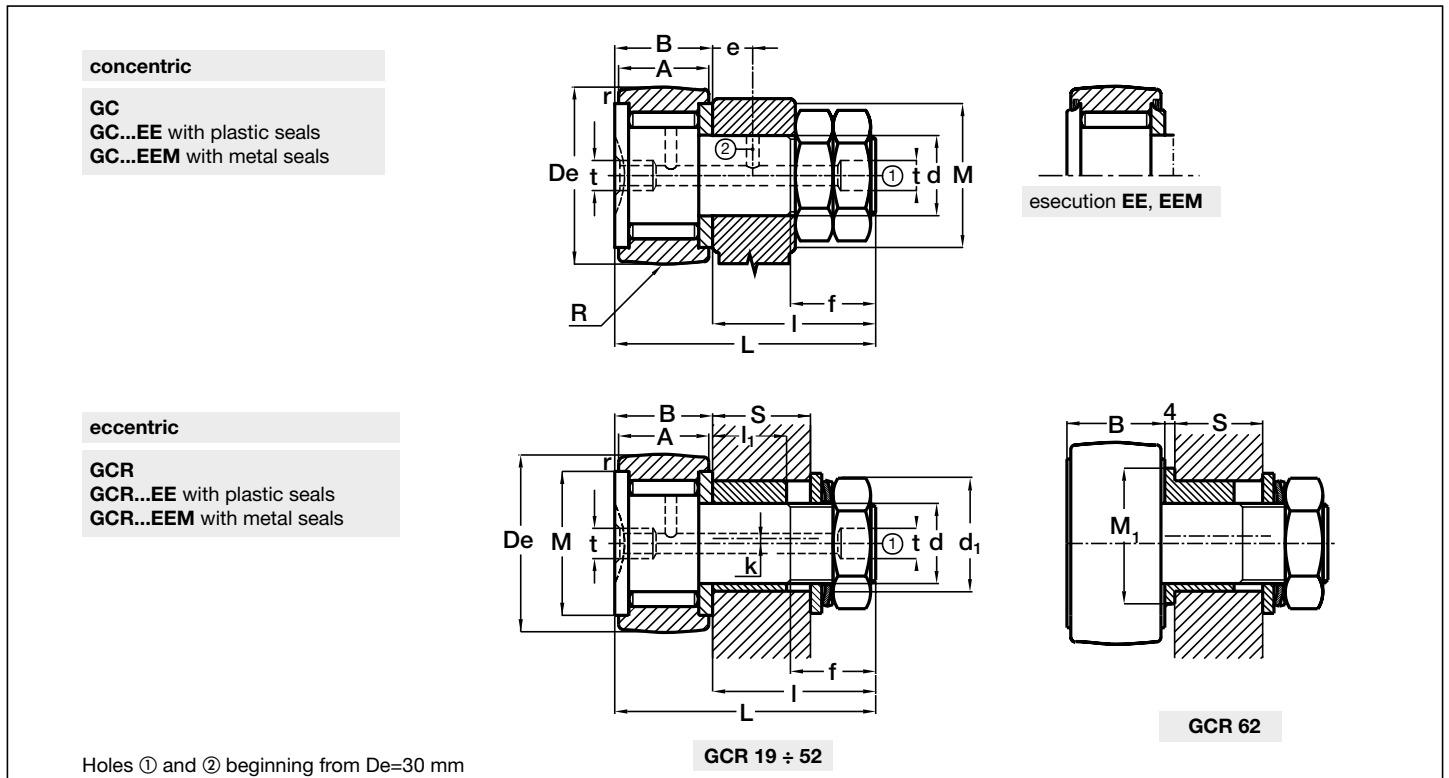

Type (1)		Dimensions (mm)																
		De	A	B max	d	d ₁ (7)	k	L max	I max	f	pitch	r min	t	e	M (6)	M ₁	P (2)	l ₁
GC 19	GCR 19	19	11	12.2	8	11	0.5	32.7	20.5	10	1.25	0.3	4	-	15.3	-	-	10
GC 22	GCR 22	22	12	13.2	10	14	1	36.7	23.5	12	1.25*	0.3	4	-	18.2	-	-	11
GC 24	GCR 24	24	12	13.2	10	14	1	36.7	23.5	12	1.25*	0.3	4	-	18.2	-	-	11
GC 26	GCR 26	26	12	13.2	10	14	1	36.7	23.5	12	1.25*	0.3	4	-	20.8	-	-	11
GC 28	GCR 28	28	12	13.2	10	14	1	36.7	23.5	12	1.25*	0.3	4	-	20.8	-	-	11
GC 30	GCR 30	30	14	15.2	12	16	1	40.7	25.5	13	1.5	0.6	4	6	24.8	-	8	11
GC 32	GCR 32	32	14	15.2	12	16	1	40.7	25.5	13	1.5	0.6	4	6	24.8	-	8	11
GC 35	GCR 35	35	18	19.6	16	21	1.5	52.6	33	17	1.5	0.6	6	8	28.8	-	10	14
GC 40	GCR 40	40	20	21.6	18	24	1.5	58.6	37	19	1.5	1	6	8	33.8	-	12	16
GC 47	GCR 47	47	24	25.6	20	27	2	66.6	41	21	1.5	1	6	9	38.7	-	14	17.5
GC 52	GCR 52	52	24	25.6	20	27	2	66.6	41	21	1.5	1	6	9	38.7	-	14	17.5
GC 62	GCR 62	62	29	30.6	24	36	3	80.6	50	25	1.5	1	6	11	52	44	12	18

* These threads may be supplied with pitch of 1 mm (clamping torque 13 Nm)

- Housing bore tolerance: H7

- The guide rollers are complete with washers and hexagonal nut for fitting

- 1) Specification for followers with cylindrical outer ring: GCL, GCRL, GCL...EE, GCL...EEM, GCRL...EEM. On request the followers can be supplied possessing a screw driver slot at the threaded end of the stud (suffix **AK**).
- 2) Followers with outer diameter up to 28 mm included possess a screw driver slot on the head. Followers with outer diameter from 30 to 52 mm included can possess the screw driver slot or the hexagonal socket. For outer diameter above 52 mm the followers possess the hexagonal socket.
- 3) The load shown is limited by the strengths of the stud and outer ring.
- 4) With oil lubrication of followers without seals GC, GCR, GCL e GCRL, these speeds can be increased by 30% for continuous rotation or up to 50% momentarily.
- 5) These torques are shown for dry threads. For lubricated threads, take 0,8 of these values.
- 6) Minimum recommended abutment diameter in case of high axial load or in the presence vibrations.
- 7) The eccentric collar is tightly fitted on the follower stud.
- 8) C_w basic load for 100 Km

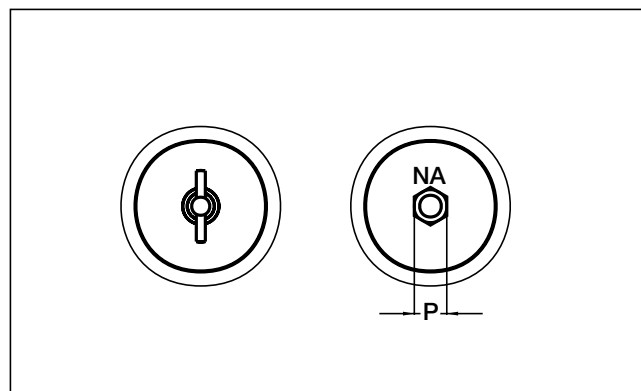

S		R	Bearing rating (N)		Limit load (3) (N)				Speed limit grease lubrication r.p.m. (4)	Torque wrench setting (Nm) (5)	
			Dynamic	Static	GC...		GCR...			GC...	GCR...
			C_w (8)	C_o	Din. F	Stat. F _o	Din. F	Stat. F _o			
min	max										
10.5	13	160	4 900	7 800	2 830	5 200	2 830	4 500	7 600	8	5
11.5	14	200	5 600	9 700	4 900	8 100	4 900	5 600	6 300	20	16
11.5	14	200	6 300	9 700	5 200	9 200	5 200	5 600	6 300	20	16
11.5	14	200	8 400	12 500	5 200	9 600	5 200	6 100	5 500	20	16
11.5	14	200	9 200	12 500	5 200	9 600	5 200	6 100	5 500	20	16
11.5	14.5	250	12 700	17 900	7 700	14 300	7 700	10 400	4 800	26	22
11.5	14.5	250	13 800	17 900	7 700	14 300	7 700	10 400	4 800	26	22
14.5	19	320	19 800	33 000	11 400	24 000	11 000	11 000	3 850	64	55
16.5	22	400	21 400	41 000	14 200	27 000	12 300	12 300	3 150	90	75
18	25	500	31 800	65 000	21 400	40 000	21 400	23 700	2 700	120	100
18	25	500	39 400	65 000	21 400	40 000	21 400	23 700	2 700	120	100
18.5	25.5	640	51 300	85 000	31 000	57 500	28 800	28 800	2 330	220	180

On request track rollers can be supplied in stainless steel (suffix **NX**)

Lubricator **LUBP** **NEW**

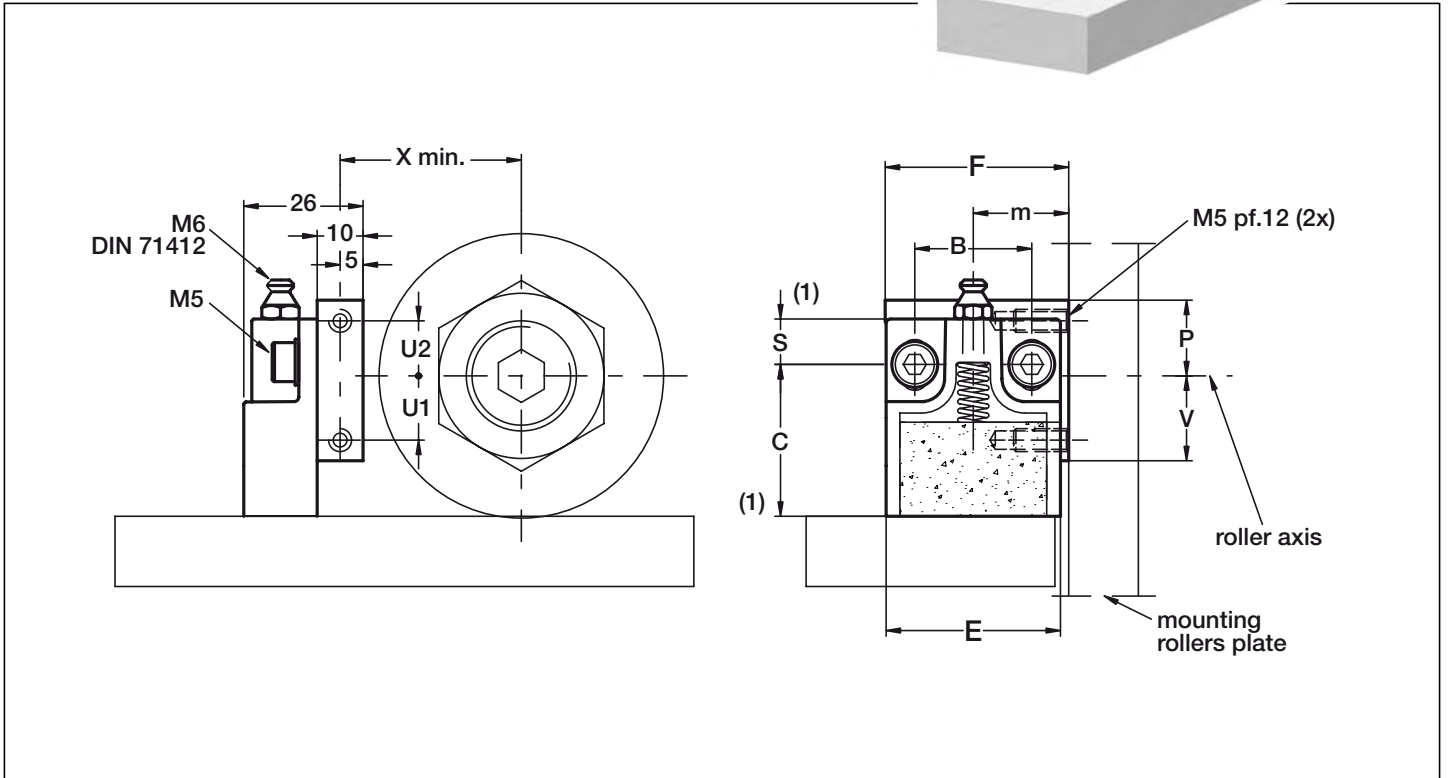
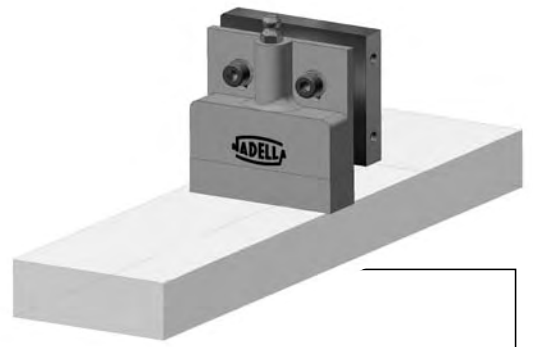

Type	Dimensions (mm)											Weight (g)	Suggested combinations
	X	U1	U2	F	m	B	S	C	E	V	P		
LUBP 52	33.5	12	14	40	19.8	25.5	10	32.5	38	16.5	18.5	65	PK 52 C PKR 52 C FK 52 C
LUBP 62	38.5	14	12	40	20.8	25.5	10	32.5	38	18.5	16.5	65	PK 62 C PKR 62 C FK 62 C
LUBP 72	43.5	19	11	50	27	25.5	10	40	44	24	16	85	PK 72 C PKR 72 C FK 72C
LUBP 90	52.5	21	9	60	30	30	16.5	43.5	58	31	19	140	PK 90 C PKR 90 C FK 90 C
LUBP 110	62.5	30	0	63	34	30	16.5	43.5	58	40	10	140	PK 110 C PKR 110 C FK 110 C

1) The dimension of the plastic part refers to the centre of the regulation slot. The regulation slot allows a translation of +/- 3 mm

2) The lubricator is supplied with the felt already lubricated. The lubricant has a mineral oil base

3) During the mounting fix the aluminium support to the rollers plate, adjust the height of the plastic part in order to put it in contact with the raceways and than block it in that position with the M5 screws.

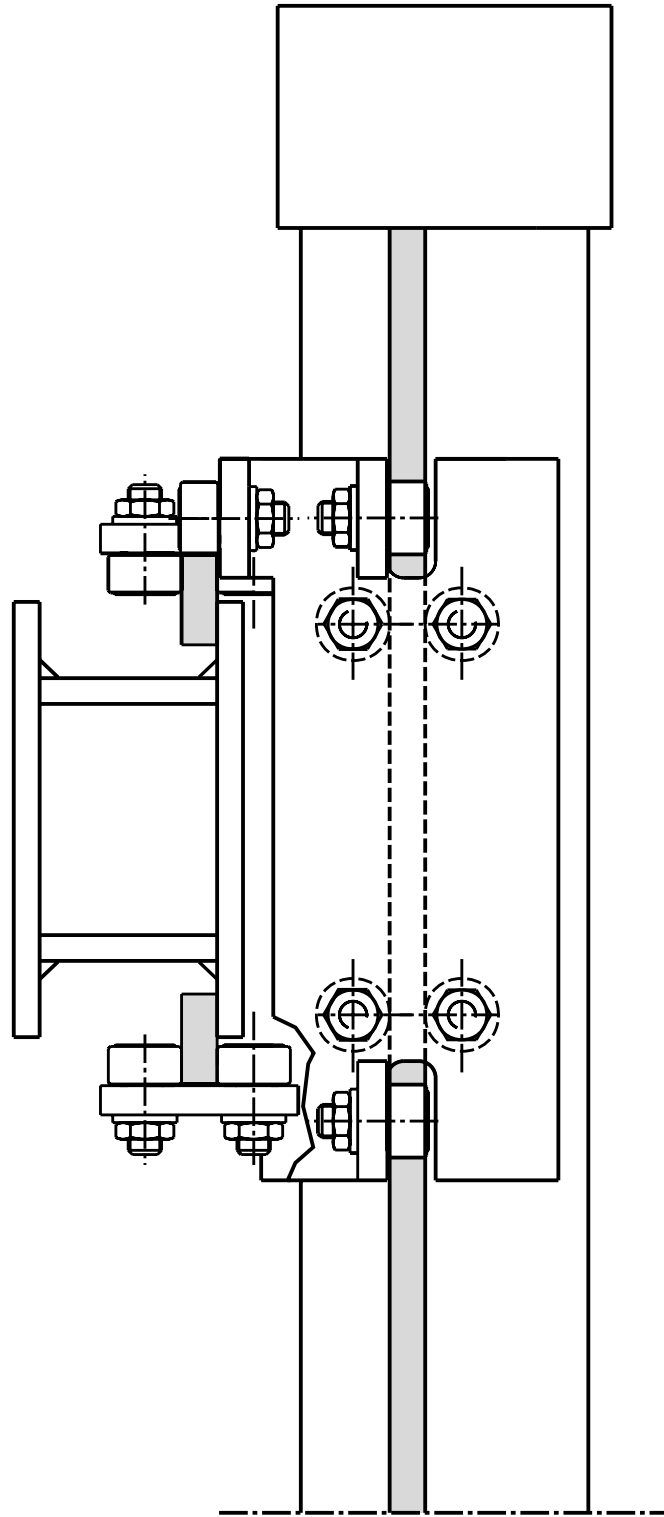

DC, C System



NADELLA

DC system

DC system is based on rails, guide rollers and carriages that provide a complete guiding system.

Rails and rollers can be used as single elements.

In most cases the application is based on standard carriages.

The load capacities are tabulated with reference to the axis system showed in the sketch below:

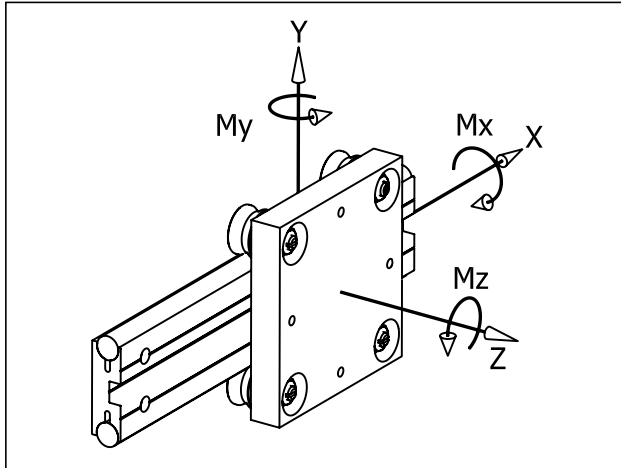

MAXIMUM LOADS ON SINGLE CARRIAGE

The following table shows the maximum loads that can be applied on a single carriage.

Rails	Carriages	Fy N	Fz N	Mx Nm	My Nm	Mz Nm
DC 10.54	T4 PFV 25 10 80	1590	800	22	18	35
	T4 PFV 25 10 120	1590	800	22	33	67
DC 16.80	T4 PFV 35 16 165	3570	1800	70	110	225
	T4 PFV 35 16 250	3570	1800	70	190	370
DC 18.65	T4 PFV 35 18 150	3940	1810	55	100	220
	T4 PFV 35 18 250	3940	1810	55	190	420
DC 25.95	T4 PFV 50 25 220	7890	3900	180	320	640
	T4 PFV 50 25 300	7890	3900	180	480	950

The maximum loads are based on the stud and bearing strengths and on a maximum contact pressure, between rail and roller, of 1250 N/mm². The load in the table are considered as acting singularly. For applications with many loads acting at the same time the loads must be reduced.

BASIC DYNAMIC LOADS OF SINGLE CARRIAGE

The following table shows the nominal loads that correspond to a nominal life of the bearing at 100 km.

The nominal lifetime of the carriage can be estimated from the standard bearing formula

$$L_{10} = (C_i/P_i)^3 \times 100 \text{ km}$$

C_i is the basic dynamic load capacity in a specific direction i and P_i is the external load applied in the same specific direction.

Rails	Carriage	Cy N	Cz N	CMx Nm	CMy Nm	CMz Nm
DC 10.54	T4 PFV 25 10 80	3700	1200	32	27	84
	T4 PFV 25 10 120	3700	1200	32	51	158
DC 16.80	T4 PFV 35 16 165	9000	2950	115	185	570
	T4 PFV 35 16 250	9000	2950	115	310	950
DC 18.65	T4 PFV 35 18 150	9000	2950	95	165	510
	T4 PFV 35 18 250	9000	2950	95	315	970
DC 25.95	T4 PFV 50 25 220	17500	6100	290	500	1400
	T4 PFV 50 25 300	17500	6100	290	750	2150

Calculation example: carriage loaded with an external load F

Carriage T4 PFV 50 25 220; F = 2000 N.

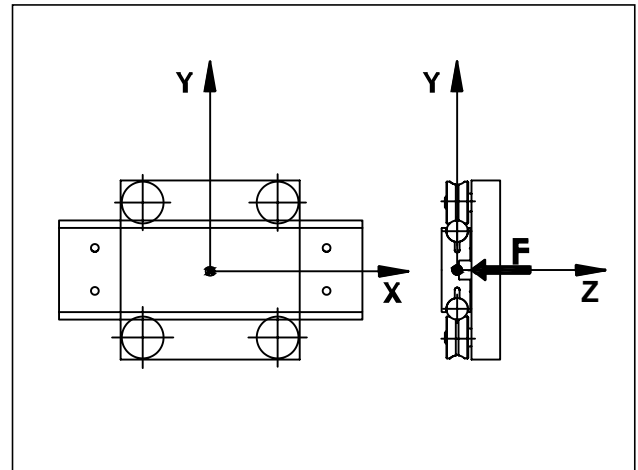

The external load F acts in the z-axis direction:

$$P_z = F = 2000 \text{ N}$$

In the table of the “maximum loads” you find that the load capacity F_z for carriage T4 PFV 50 25 220 is equal to 3900 N, so the system is validated against breakage.

To estimate the system lifetime we proceed as follows: from the table of the “basic dynamic loads” we see that C_z, for the carriage T4 PFV 50 25 220, is equal to 6100 N.

The nominal lifetime will be:

$$L_{10} = (6100/2000)^3 \times 100 = 2837 \text{ km}$$

Important notes:

- in order to reach the calculated lifetime it is important to lubricate the rails;
- for load configurations with many loads and moments acting at the same time in different directions, please refer to the calculation examples you can find at the beginning of the catalogue or contact our Technical department.

Guide Rails DC

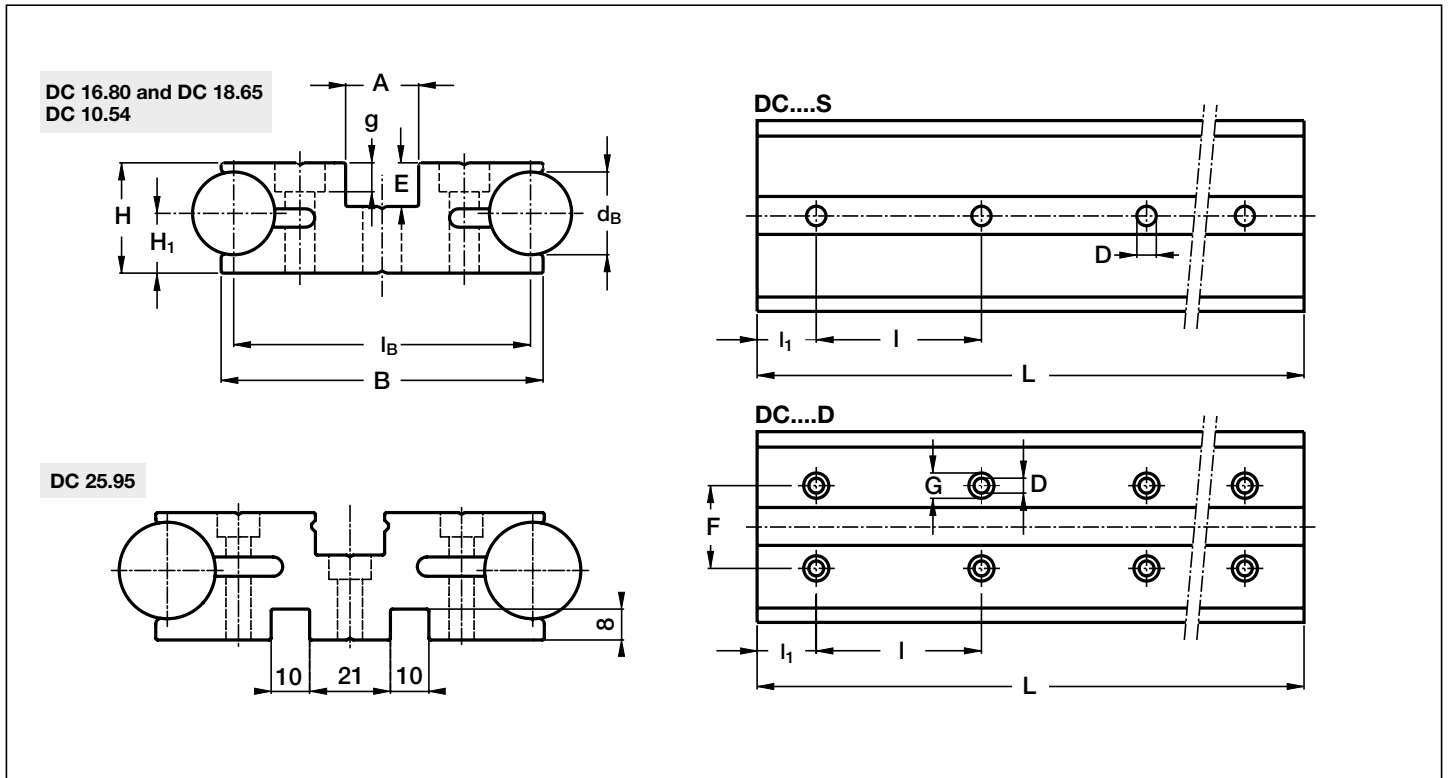

Type	Dimensions (mm)													Moments of inertia ⁽²⁾ (cm ⁴)		Weight (kg/m)
	d _B	l _B	B	H	H ₁	A	E	D	G	g	F	l	l ₁	J _x	J _y	
DC 10.54 S ⁽³⁾	10	54	57	19.5	13	25	10.5	6.5	-	-	-	150	30	2.16	20.5	3.15
DC 10.54 D ⁽³⁾	10	54	57	19.5	13	25	10.5	4.4	8	4.2	36	150	30	2.16	20.5	3.15
DC 16.80 S ⁽³⁾	16	80	86	25.5	14.5	18	9.5	8.5	-	-	-	150	30	9.6	85	7.1
DC 16.80 D ⁽³⁾	16	80	86	25.5	14.5	18	9.5	6.5	11	6.3	54	150	30	9.6	85	7.1
DC 18.65 S	18	65	70.5	24	13	16	9.5	8.5	-	-	-	150	30	6.1	34.7	7
DC 18.65 D	18	65	70.5	24	13	16	9.5	6.5	11	6.3	36	150	30	6.1	34.7	7
DC 25.95 S ^{(4) (3)}	25	95	101	33	18	19	13	10.5	-	-	-	150	30	21.8	142.2	13.5
DC 25.95 D ^{(4) (3)}	25	95	101	33	18	19	13	6.5	11	6.3	58	150	30	21.8	142.2	13.5

max length in single element L=6000 ⁽¹⁾

1) longer rails are supplied in sections with ground butt joints and, on request, with pin connection

2) Inertia value based on equivalent aluminium yield 70000 N/mm²

3) available with stainless steel shafts

4) available with hollow shafts

Hole layout

- holes according to catalogue (**SB**)
- finishes to drawing (**NZ**)
- without holes (**NF**)

Optional features

- ground one end (**R**)
- ground both ends (**RR**)
- Stainless steel shafts (**NX**)
- Chromium plated shafts (**CH**)
- Hollow shafts (**AC**) only for note (4)

Example of standard designation: **DC2595 S/2010/SB/NX**

See page 15 for standard codification

Guide Rails C

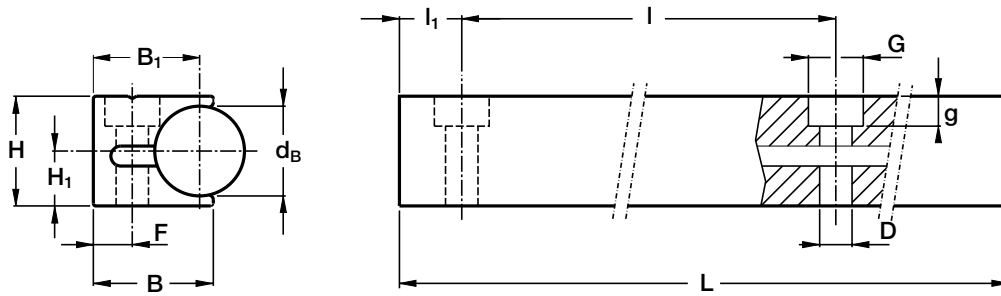

Type	Dimensions (mm)											Moments of inertia ⁽²⁾ (cm ⁴)		Weight (kg/m)
	d _B	B	B ₁	H	H ₁	D	G	g	F	l	l ₁	J _x	J _y	
C 10 ⁽³⁾	10	16.9	15.4	14.5	8	4.4	8	4.2	6.5	100	30	0.4	0.3	1.1
C 18	18	24	21.3	22	11	6.5	11	6.3	7.8	150	50	1.7	1.1	2.8
C 22	22	28	25	26.5	13.5	6.5	11	6.3	9	160	50	3.5	2.0	4.1
C 30 ^{(3) (4)}	30	36	32.5	36	19	9	15	8.3	11.5	180	60	11.1	5.6	7.6

max length in single element L=6000 ⁽¹⁾

1) longer rails are supplied in sections with ground butt joints and, on request, with pin connection

2) Inertia value based on equivalent aluminium yield 70000 N/mm²

3) available with stainless steel shafts

4) available with hollow shafts

Hole layout

- holes according to catalogue (**SB**)
- finishes to drawing (**NZ**)
- without holes (**NF**)

Optional features

- ground one end (**R**)
- ground both ends (**RR**)
- Stainless steel shafts (**NX**)
- Chromium plated shafts (**CH**)

Example of standard designation: **C10/2060/SB**

See page 15 for standard codification

Guide rollers **PFV** with “gothic arch” profile

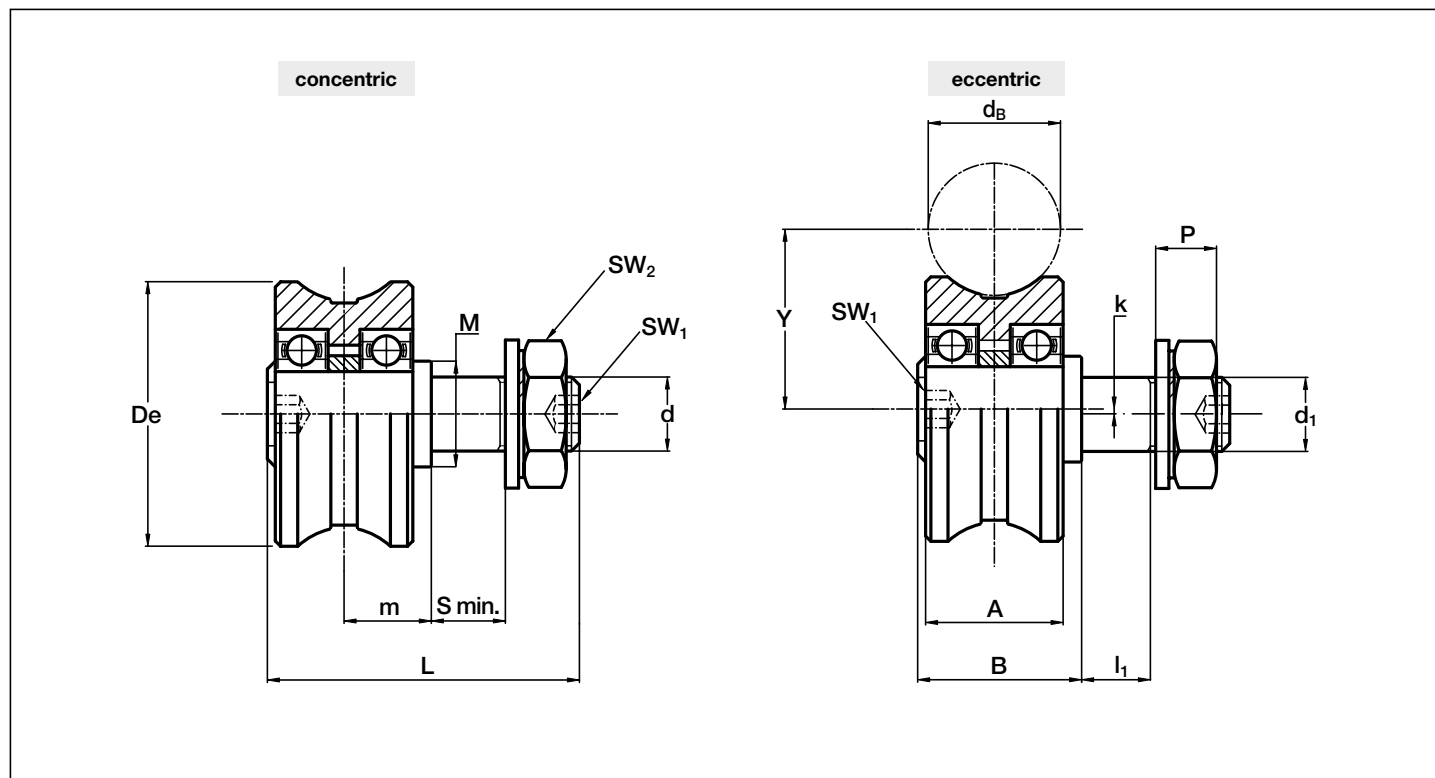

Type		Dimensions (mm)														Recommended pairings		
concentric	eccentric	De	dB	d ₁ ⁽¹⁾	d	Y	m	S min.	P	L	A	B	I ₁	M	SW ₁	SW ₂	k	
PFV 25.10 ⁽³⁾	PFVR 25.10 ⁽³⁾	25	10	8	M8x1.25	15.5	7.5	11	9	34.8	12	14.8	10	12	4	ch.13	0.75	C 10/DC 10.5
PFV 35.16 ⁽³⁾	PFVR 35.16 ⁽³⁾	35	16	10	M10x1.25	23	12	12	10.7	45.3	18	22.3	11	15	4	ch.17	0.75	DC 16.80
PFV 35.18 ⁽³⁾	PFVR 35.18 ⁽³⁾	35	18	10	M10x1.25	24	12	12	10.7	45.3	18	22.3	11	15	4	ch.17	0.75	C 18/DC 18.65
PFV 43.22 ⁽³⁾	PFVR 43.22 ⁽³⁾	43	22	12	M12x1.5	29	14	13	12.5	52	23	27	12	18	5	ch.19	1	C 22
PFV 50.25 ⁽³⁾	PFVR 50.25 ⁽³⁾	50	25	14	M14x1.5	34	16.5	14	13.5	59	26	31	13	20	6	ch.22	1	C 25.95
PFV 60.30	PFVR 60.30	60	30	16	M16x1.5	41	19.5	17	14	69.5	31	36.5	16	30	8	ch.24	1	C 30

Type		Bearing rating (N)			Limit loads (N)		Life coefficients		Torque wrench ⁽²⁾ settings (Nm)	Weight (g)
		Dynamic C _w ⁽⁴⁾	Static		radial F _r	Axial F _a	X	Y		
			C _{or}	C _{oa}						
PFV 25.10	PFVR 25.10	1 850	1 080	200	1 740	450	1	4.4	8	42
PFV 35.16	PFVR 35.16	4 550	2 320	430	2 120	570	1	4.4	20	115
PFV 35.18	PFVR 35.18	4 570	2 320	430	2 120	570	1	4.4	20	113
PFV 43.22	PFVR 43.22	7 600	4 000	780	3 150	820	1	4	26	210
PFV 50.25	PFVR 50.25	8 800	4 800	940	4 240	1 100	1	4	44	335
PFV 60.30	PFVR 60.30	15 700	8 500	1 560	5 360	1 350	1	4.3	64	570

1) Housing bore tolerance: H7

2) The torque wrench settings are given for non-lubricated threads; for lubricated threads, multiply figure by 0.8

3) Available in stainless steel (suffix **NX**)

4) C_w basic load for 100 km

5) The guide rollers are complete with self-locking washers and hexagonal nut for fitting

6) Pressure angle α for load calculation: 60°

7) NBR seals, RS type

Guide rollers **PFV** straight profile

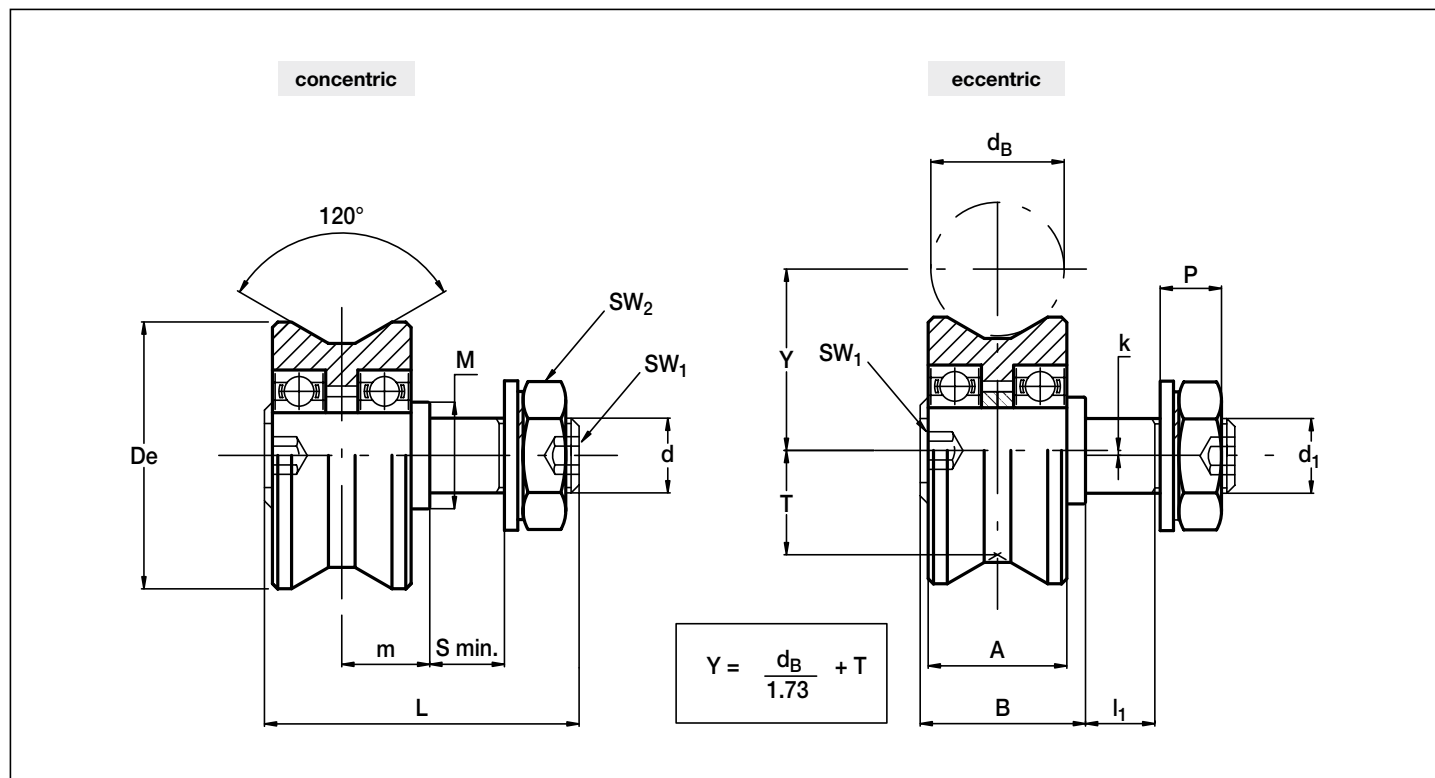

Type		Dimensions (mm)															
concentric	eccentric	De	dB	d ₁ ⁽¹⁾	d	T	m	S min.	P	L	A	B	l ₁	M	SW ₁	SW ₂	k
PFV 25	PFVR 25	25	from 6 to 18	8	M 8x1.25	9.7	7.5	11	9	34.8	12	14.8	10	12	4	ch. 13	0.75
PFV 35	PFVR 35	35	from 14 to 25	10	M10x1.25	13.6	12	12	10.7	45.3	18	22.3	11	15	4	ch. 17	0.75
PFV 43	PFVR 43	43	from 18 to 30	12	M12x1.5	16.3	14	13	12.5	52	23	27	12	18	5	ch. 19	1
PFV 50	PFVR 50	50	from 20 to 35	14	M14x1.5	19.6	16.5	14	13.5	59	26	31	13	20	6	ch. 22	1
PFV 60	PFVR 60	60	from 22 to 40	16	M16x1.5	23.7	19.5	17	14	69.5	31	36.5	16	30	8	ch. 24	1

Type		Bearing rating (N)			Limit loads (N) ⁽³⁾		Life coefficients		Torque wrench (Nm) ⁽²⁾ settings	Weight (g)
		Dynamic	Static		radial F _r	Axial F _a	X	Y		
			C _w ⁽⁴⁾	C _{or}						
PFV 25	PFVR 25	1 850	1 080	200	1 740	450	1	4.4	8	42
PFV 35	PFVR 35	4 550	2 320	430	2 120	570	1	4.4	20	115
PFV 43	PFVR 43	7 600	4 000	780	3 150	820	1	4	26	210
PFV 50	PFVR 50	8 800	4 800	940	4 240	1 100	1	4	44	335
PFV 60	PFVR 60	15 700	8 500	1 560	5 360	1 350	1	4.3	64	570

1) Housing bore tolerance: H7

2) Torque wrench settings are given for non-lubricated threads; for lubricated threads, multiply figure by 0.8

3) In order to avoid the wear of the raceways the applied load must be smaller than 25% of limit load

4) C_w basic load for 100 km

5) Guide rollers are complete with self-locking washers and hexagonal nut for fitting

6) Pressure angle α for load calculation: 60°C

7) Standard seals: material NBR, type RS

Guide rollers **RKO**

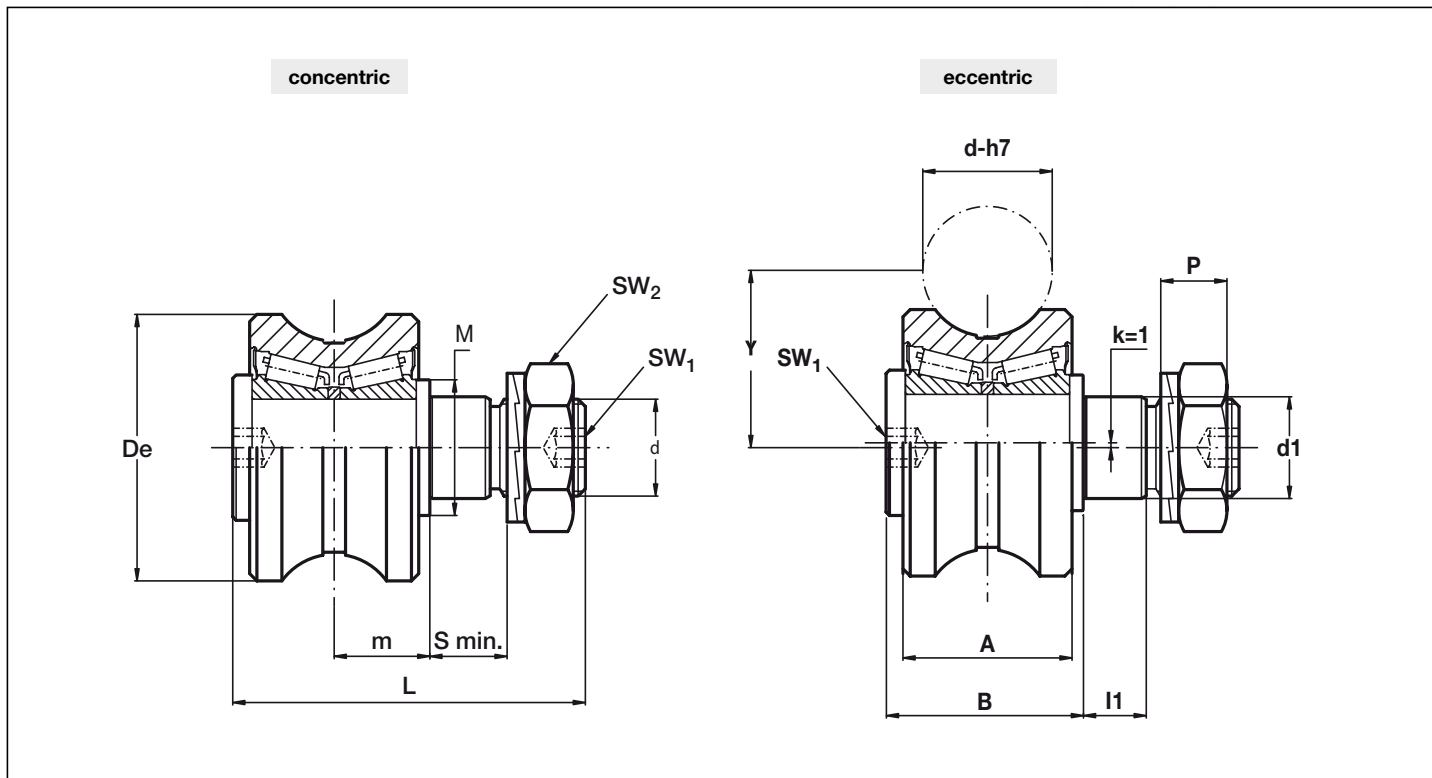

Type		Dimensions (mm)															
concentric	eccentric	De	d-h7	d ₁ ⁽¹⁾	d	Y	m	S min.	P	L	A	B	l ₁	M	SW ₁	SW ₂	k
RKO 55.20	RKOR 55.20	55	20	21	M 20 x 1.5	32.9	19.8	15	13.4	73	35	41	14	28	8	ch. 30	1
RKO 55.25	RKOR 55.25	55	25	21	M 20 x 1.5	34.3	19.8	15	13.4	73	35	41	14	28	8	ch. 30	1
RKO 62.30	RKOR 62.30	62	30	21	M 20 x 1.5	39.6	19.8	15	13.4	73	55	41	14	28	8	ch. 30	1
RKO 80.40	RKOR 80.40	79	40	36	M 30 x 1.5	50.7	27	19	19.6	100	45	55	18	44	12	ch. 46	1

Type		Bearing rating (N)			Limit loads (N)		Life coefficients				Torque wrench (Nm) ⁽²⁾ settings	Weight (kg)
		Dynamic	Static				Pa/Pr ≤ 0.1		Pa/Pr > 0.1			
		C _w ⁽⁴⁾	radial C _{or}	axial C _{oa}	radial F _r	axial F _a	X	Y	X	Y		
RKO 55.20	RKOR 55.20	40 750	44 000	12 400	11 900	3 550	1	4.67	0.77	6.98	80	0.6
RKO 55.25	RKOR 55.25	40 750	44 000	12 400	11 900	3 450	1	4.67	0.77	6.98	80	0.6
RKO 62.30	RKOR 62.30	46 000	44 000	12 400	11 900	3 150	1	4.67	0.77	6.98	80	0.7
RKO 80.40	RKOR 80.40	64 850	72 000	18 900	31 300	10 100	1	4.67	0.77	6.98	300	1.6

1) Housing bore tolerance: H7

2) Torque wrench settings are given for non-lubricated threads; for lubricated threads, multiply figure by 0.8

3) Standard seals: material NBR, type RS

4) On request, the guide rollers can be supplied with Viton seals for operating temperatures up to 120°C (suffix **V**)

5) C_w basic load for 100 km

6) The guide rollers is complete with self-locking washers and hexagonal nut for fitting

7) Pressure angle α for load calculation: 60°C

Carriages **T4PFV**

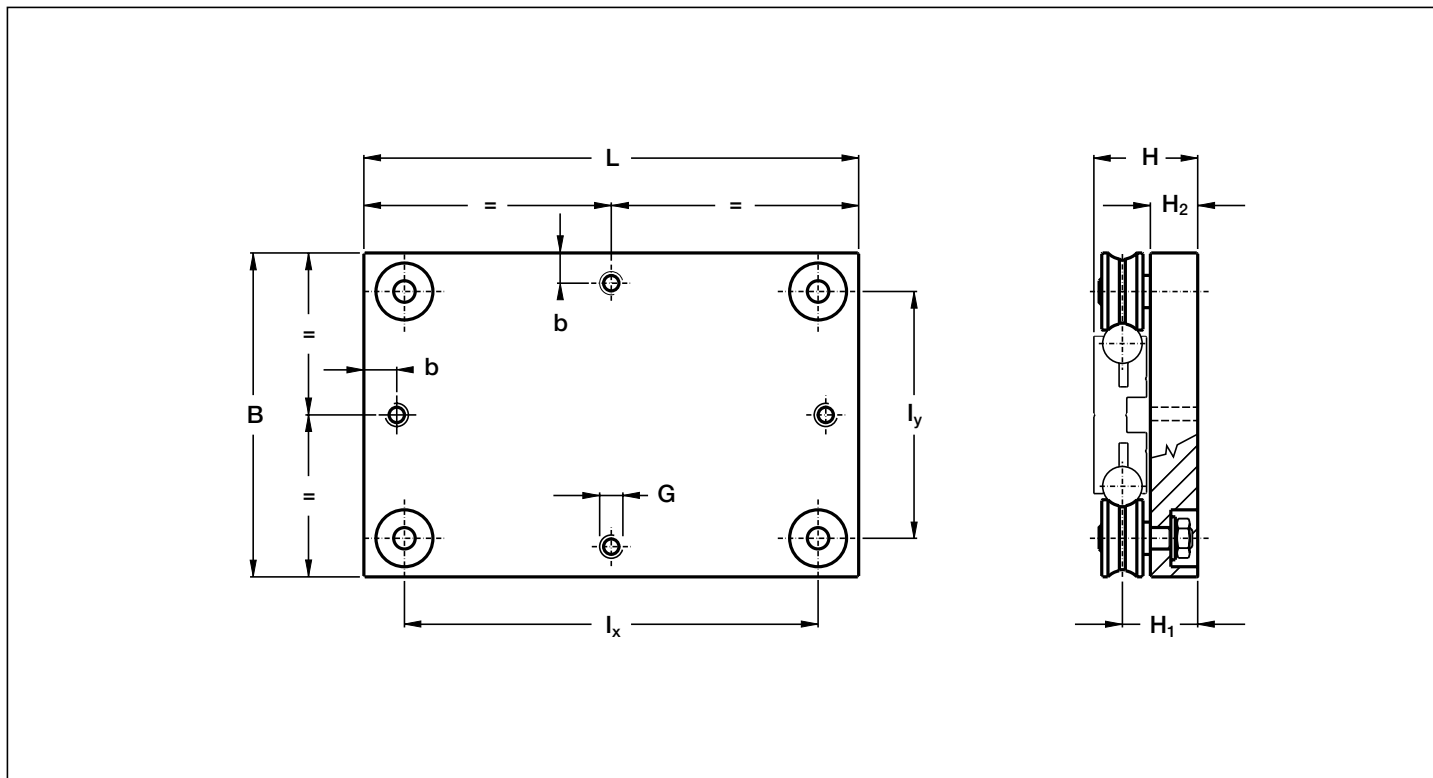

Type	Dimensions (mm)										Weight (kg)	Recommended pairings
	L	B	I _x	I _y	H	H ₁	H ₂	G	b			
T4PFV 25 10 80 ⁽¹⁾	80	120	45	85	41	28	20.5	M8	15	0.69	DC 10.54	
T4PFV 25 10 120 ⁽¹⁾	120	120	85	85	41	28	20.5	M8	15	0.96	DC 10.54	
T4PFV 35 16 165 ⁽¹⁾	165	165	126	126	50.5	36	24	M8	15	2.1	DC 16.80	
T4PFV 35 16 250 ⁽¹⁾	250	165	211	126	50.5	36	24	M8	15	3.1	DC 16.80	
T4PFV 35 18 150 ⁽¹⁾	150	150	113	113	49	36	24	M8	15	1.8	DC 18.65	
T4PFV 35 18 250 ⁽¹⁾	250	150	213	113	49	36	24	M8	15	2.8	DC 18.65	
T4PFV 50 25 220 ⁽¹⁾	220	220	163	163	63.5	45.5	29	M10	20	5	DC 25.95	
T4PFV 50 25 300 ⁽¹⁾	300	220	243	163	63.5	45.5	29	M10	20	6.4	DC 25.95	

- 1) Available with stainless steel guide rollers (**NX**)
- 2) Carriages are complete with guide rollers
- 3) Pressure angle α for load calculation: 60°

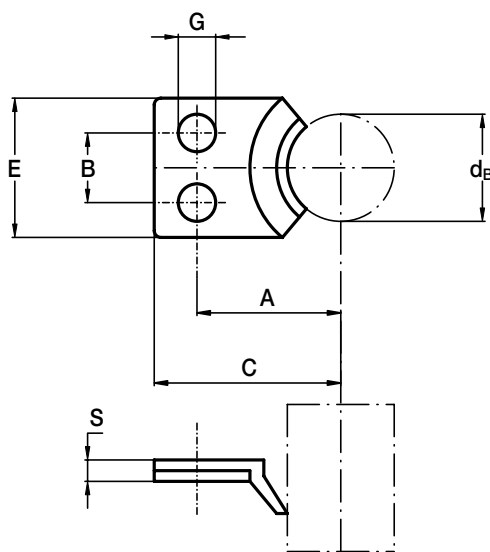

Type	Dimensions (mm)								Recommended pairings
	d_B	E	C	A	B	G	A	S	
NAID 010	10	13	17.5	13.5	6.5	3.5	12	3	C 10
NAID 016	16	20	26.5	20.5	10	4.5	18	3	DC 16.80
NAID 018	18	20	26.5	20.5	10	4.5	18	3	C 18/DC 18.65
NAID 022	22	24	30	24	14	4.5	23	3	C 22
NAID 025	25	28	37.5	30.5	18	4.5	26	3	C 25.95
NAID 030	30	32	45.5	37.5	20	5.5	31	3	C 30

Lubricator **LUBC** **NEW**

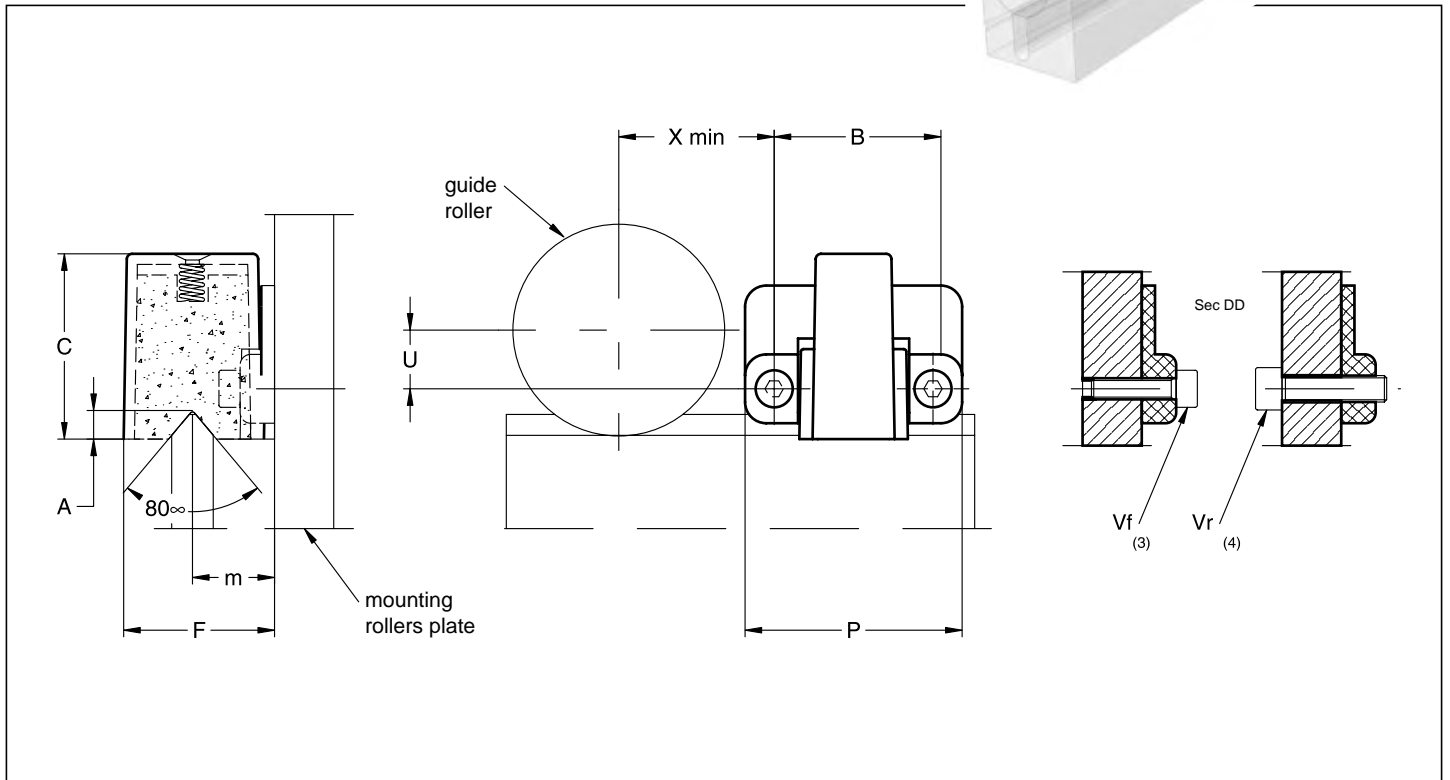
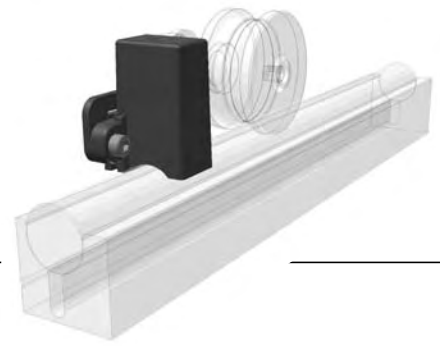

Type	Dimensions (mm)											Weight (g)	Suggested combinations
	X	U	B	F	m	dB	A	C	P	Vf	Vr		
LUBC 25.10	18	4.5	25	13	7.5	10	3	22	32.5	M3x12	M4	10	PFV... 25...
LUBC 35.16	23	9.5	25	22	12	16	5.5	32	32.5	M3x12	M4	15	PFV... 35...
LUBC 35.18	23	9.5	25	22	12	18	6.5	32	32.5	M3x12	M4	15	PFV... 35...
LUBC 43.22	29	12	30	25.5	14	22	22	35	41	M4x12	M5	30	PFV... 43...
LUBC 50.25	32.5	15.5	30	30.5	16.5	25	9	45	41	M4x12	M5	35	PFV... 50...
LUBC 60.32	37.5	20.5	30	36.5	19.5	30	11	50	41	M4x12	M5	40	PFV... 60...

1) The lubricator is supplied with the felt already lubricated. The lubricant has a mineral oil base

2) At the mounting, insert the screws inside the rollers plate, without tightening them, adjust the height of the plastic part in order to put it in contact with the raceways and then block it

3) The screws Vf for the frontal mounting are included in the packaging. Arrange two thread holes for dimension Vf in the mounting rollers plate

4) The screw for the mounting on the nut side of the roller are not included in the packaging. Arrange on the mounting rollers plate the holes in order to insert the screws Vr

Mounting Examples

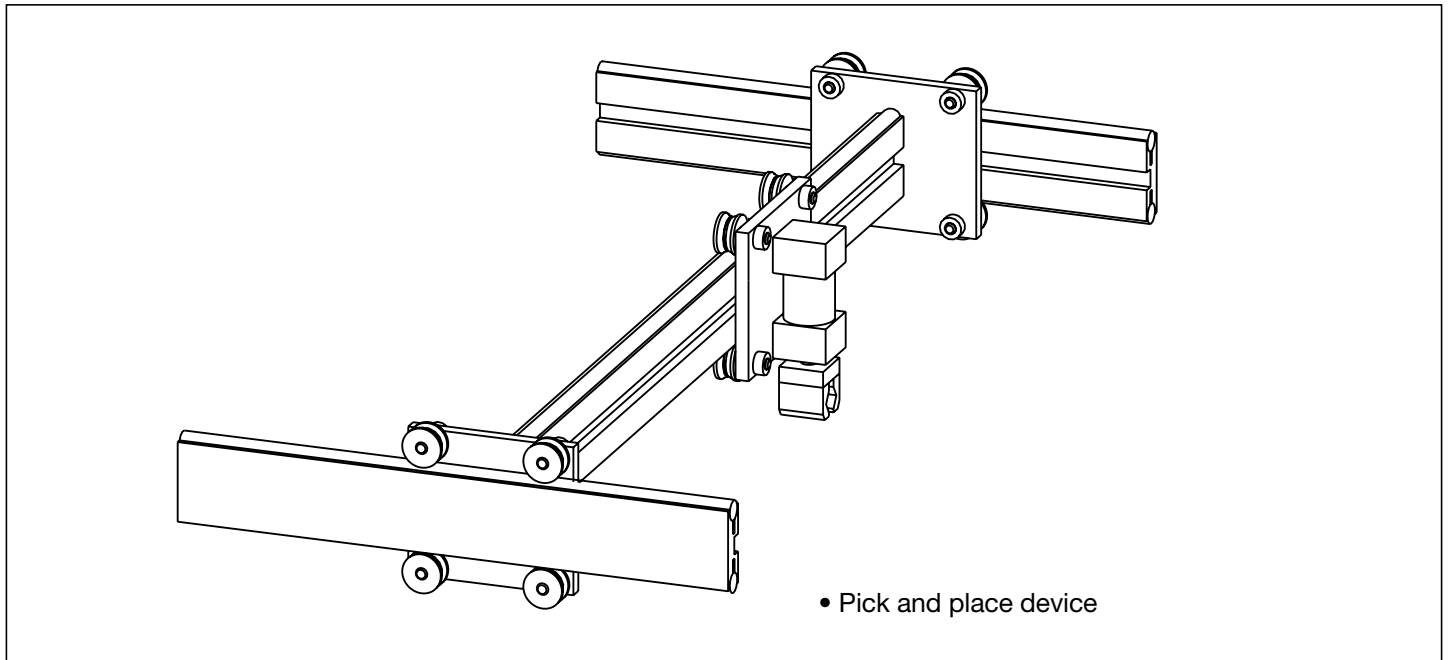

FWS, FWH System



NADELLA

Guide Rails **FWS**

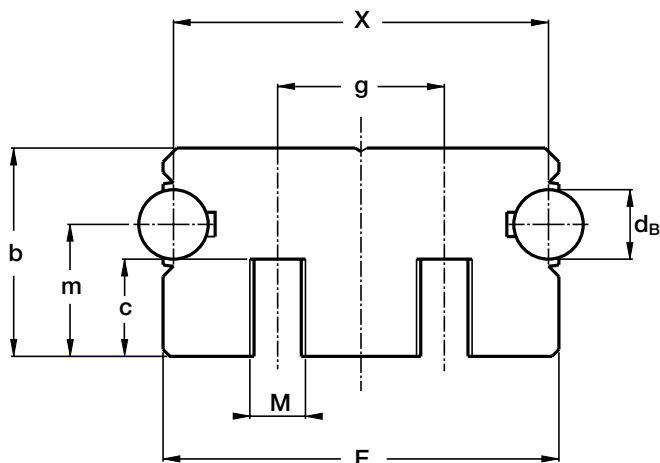

Type	Dimensions (mm)							
	d_B	X	M	g	E	b	m	c
FWS 22	6	34	M 5	16	36	20	14	10
FWS 32	8	42	M 6	20	45	25	17	12
FWS 40	10	54	M 8	24	57	30	19	14
FWS 52	12	66	M 10	32	69	36	24	18

single guide element L=4500 ⁽¹⁾

Type	Screw distance max.			Momentsof inertia ⁽²⁾ cm ⁴		Weight (kg/m)
	for 2 screw channels		for additional holes (NZ)	J_x	J_y	
	Distance (mm)	Torque wrench settings (Nm)	Distance (mm)			
FWS 22	190	2	220	2.07	6.01	2
FWS 32	210	5	240	5.1	14.56	3.3
FWS 40	250	15	280	11.01	35.26	5
FWS 52	250	23	280	22.85	74.12	7.2

1) longer rails are supplied in sections with ground butt joints at the rods

2) Inertia value based on equivalent aluminium yield 70000 N/mm² including shafts

Hole layout

- finishes to drawing (**NZ**)
- without holes (**NF**)

Optional features

- ground one end (**R**)
- ground both ends (**RR**)
- Stainless steel shafts (**NX**)

Example of standard designation: **FWS32 S/1500/NF**

See page 15 for standard codification

Guide Rails **FWH**

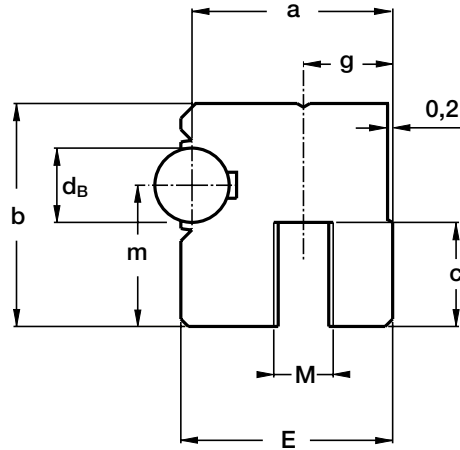

Type	Dimensions (mm)							
	d_B	a	M	g	E	b	m	c
FWH 22	6	17	M5	8	18	20	14	10
FWH 32	8	21	M5	10	22.5	25	17	12
FWH 40	10	27	M8	12	28.5	30	19	14
FWH 52	12	33	M10	16	34.5	36	24	18

Maximum length of single guide element L = 4 500 ⁽¹⁾

Type	Screw distance max.			Moments of inertia ⁽²⁾ cm ⁴		Weight (kg/m)
	for 1 screw channels		for additional holes	J_x	J_y	
	Distance (mm)	Torque wrench settings (Nm)	Distance (mm)			
FWH 22	70	2	120	1.02	0.83	1
FWH 32	60	5	130	2.55	2.05	1.6
FWH 40	97	15	150	5.71	4.75	2.5
FWH 52	120	23	150	10.12	11.85	3.6

1) longer rails are supplied in sections with ground butt joints

2) Inertia value based on equivalent aluminium yield 70000 N/mm² including shafts

Hole layout

- finishes to drawing (**NZ**)
- without holes (**NF**)

Optional features

- ground one end (**R**)
- ground both ends (**RR**)
- Stainless steel shafts (**NX**)

Example of standard designation: **FWS32 S/1500/NF**

See page 15 for standard codification

Guide Rollers **FR..EI**

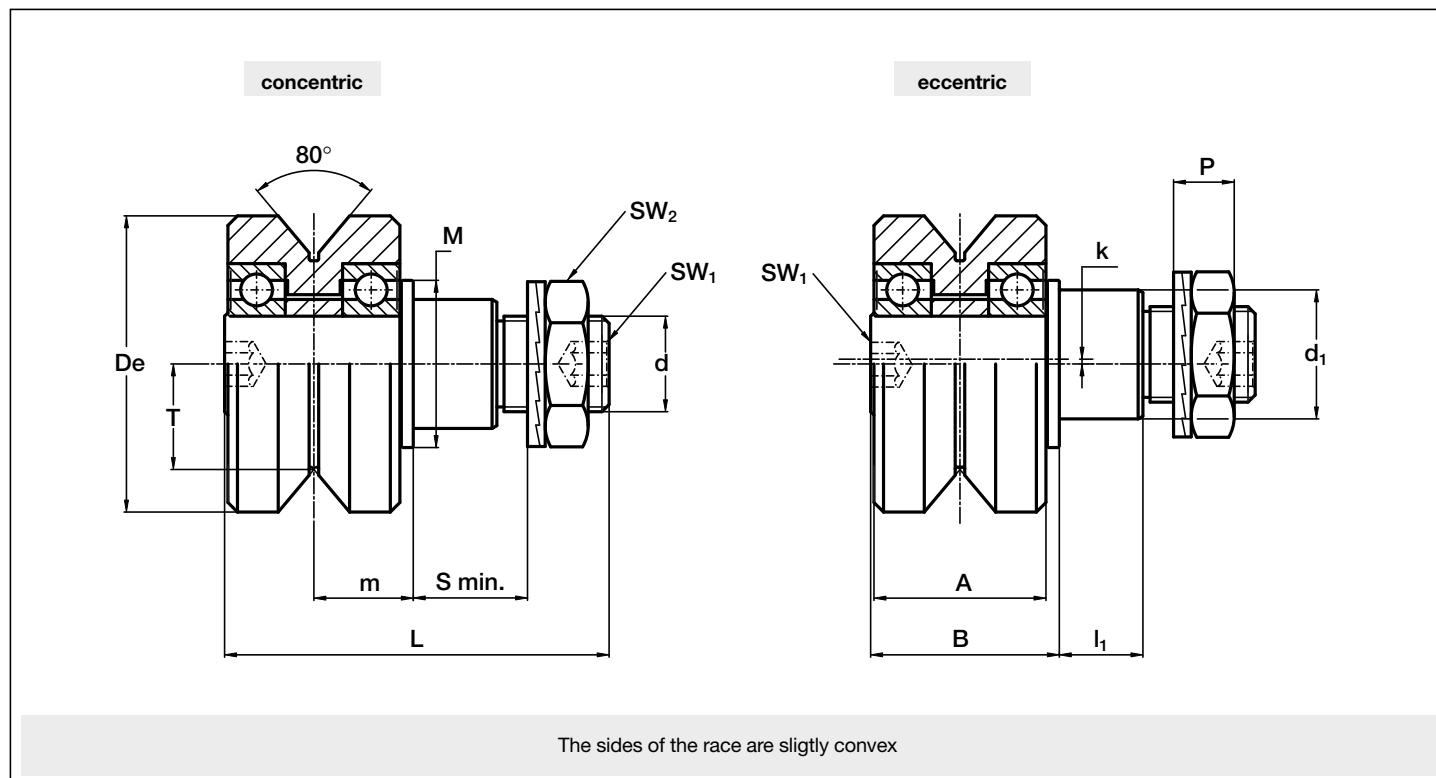

Type		Dimensions (mm)														
concentric	eccentric	De	d ₁ ⁽¹⁾	d	T	m	S min.	P	L	A	B	l ₁	M	SW ₁	SW ₂	k
FR 22 EI	FRR 22 EI	22	9	M 6 x 1	7.7	9.4	9	6.5	37	15	18.2	8	14	4	ch. 10	0.5
FR 32 EI	FRR 32 EI	32	14	M 10 x 1.25	11.8	12.6	12	8.5	50.5	21	24.5	11	20	4	ch. 16	1
FR 40 EI	FRR 40 EI	40	16	M 12 x 1.5	14.6	15.5	12	10.4	59.5	28	30.5	11	22	5	ch. 18	1
FR 52 EI	FRR 52 EI	52	21	M 16 x 1.5	19.1	19.8	15	11.4	69.5	32	36.5	14	28	6	ch. 24	1.5
FR 62 EI	FRR 62 EI	62	27	M 20 x 1.5	22.1	20.8	18.5	12.4	80.5	36	39.5	17.5	35	8	ch. 30	2

Type		Bearing rating (N)			Limit loads (N)		Life coefficients		Torque wrench ⁽²⁾ settings (Nm)	Weight (g)
		Dynamic	Static							
			C _w ⁽⁴⁾	radial C _{or}	axial C _{oa}	radial F _r	axial F _a	X		
FR 22 EI	FRR 22 EI	1 800	1 080	350	1 700	720	1	2.20	3	45
FR 32 EI	FRR 32 EI	4 400	2 330	750	1 200	500	1	2.92	20	130
FR 40 EI	FRR 40 EI	7 350	4 000	1 300	3 000	1 300	1	2.75	26	260
FR 52 EI	FRR 52 EI	9 500	5 500	1 750	7 500	3 000	1	2.96	64	510
FR 62 EI	FRR 62 EI	15 500	8 500	2 750	10 900	4 200	1	3.07	120	820

1) Housing bore tolerance: H7

2) The torque wrench settings are given for non-lubricated threads; for lubricated threads, multiply figure by 0.8

3) On request, the guide rollers can be supplied in AISI 440 stainless steel (suffix **NX**)

4) C_w basic load for 100 km

5) The guide rollers are complete with self-locking washers and hexagonal nut for fitting

6) Pressure angle α for load calculation: 40°

7) NBR seals RS type

Guide Rollers **FR**

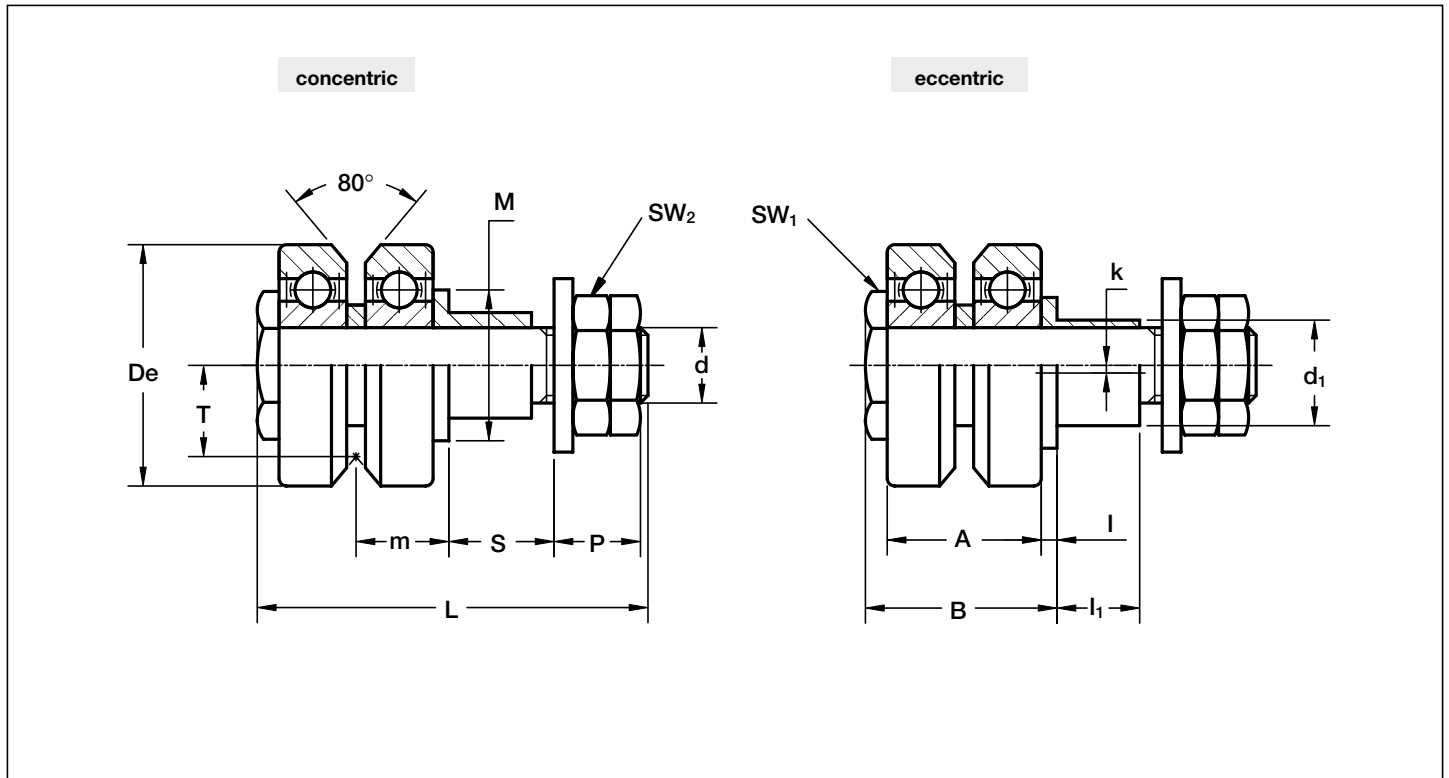

Type		Dimensions (mm)															
concentric	eccentric	De	d ₁ ⁽¹⁾	d	T	m	S min.	P	L	A	B	I ₁	I	M	SW ₁	SW ₂	k
FR 22	FRR 22	22	9	M 6 x 1	8	9.2	9	7.7	39	13.9	19.5	8	2.2	14	10	10	0.5
FR 32	FRR 32	32	14	M 10 x 1.25	12.1	12.4	12	11.5	52	20.5	25.5	11	2.1	20	17	17	1
FR 40	FRR 40	40	16	M 12 x 1.5	14.6	15.5	12	13.5	60	25	31	11	3	22	22	19	1
FR 52	FRR 52	52	21	M 16 x 1.5	19.1	19.8	15	17	73	32	40	14	3.8	28	27	24	1.5

Type		Bearing rating (N)			Limit loads (N)		Life coefficients		Torque wrench ⁽²⁾ settings (Nm)	Weight (g) ⁽³⁾
		Dynamic C _w ⁽⁴⁾	Static		radial F _r	axial F _a	X	Y		
			radial C _{or}	axial C _{oa}						
FR 22	FRR 22	700	415	105	800	380	1	0.593	3	43
FR 32	FRR 32	1 480	830	210	2 770	1 240	1	0.593	20	132
FR 40	FRR 40	2 440	1 300	325	3 830	1 720	1	0.593	26	235
FR 52	FRR 52	4 130	2 120	530	7 100	3 150	1	0.593	64	490

1) Housing bore tolerance: H7

2) The torque wrench settings are given for non-lubricated threads; for lubricated threads, multiply figure by 0.8

3) Weight without fittings

4) C_w basic load for 100 km

5) The guide rollers are completed with conical spring washer, nut and counter nut

6) Pressure angle α for load calculation: 40°

7) NBR seals RS type

Guide Rollers **FR..AS**

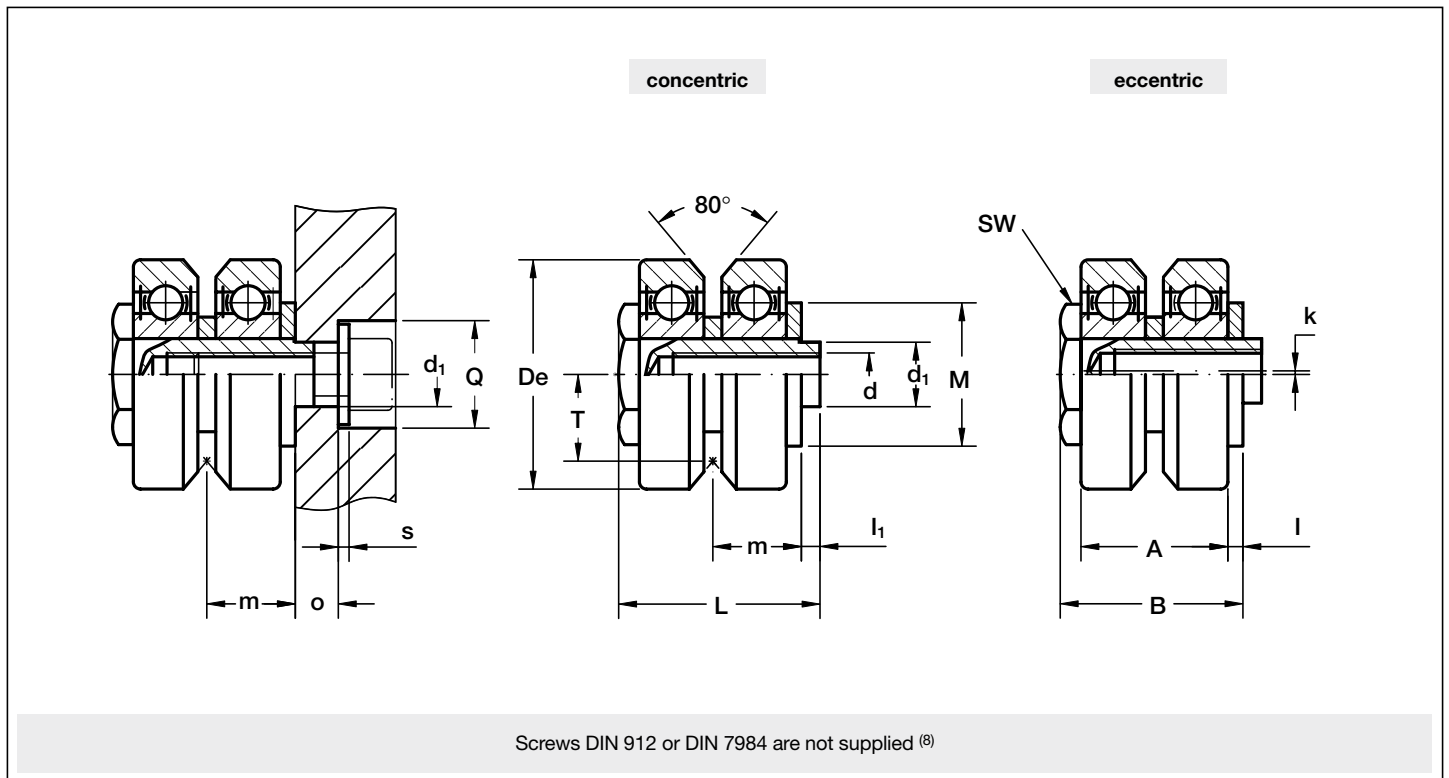

Type		Dimensions (mm)															
concentric	eccentric	De	d ₁ ⁽¹⁾	d ⁽²⁾	T	m	L	A	B	l ₁	I	M	SW	o	Q	s	k
FR 22 AS	FRR 22 AS	22	6	M 5	8	9.2	21.5	13.9	19.5	2	2.2	14	10	4.5	10	0	0.5
FR 32-1 AS	FRR 32-1 AS	32	9	M 6	12.1	12.4	28.1	20.5	25.5	2.6	2.1	20	17	6	15	1.5 ⁽⁵⁾	0.5
FR 40-1 AS	FRR 40-1 AS	40	13	M 8	14.6	15.5	33.5	25	31	2.5	3	25	22	6.5	20	2 ⁽⁵⁾	1
FR 52-1 AS	FRR 52-1 AS	52	16	M 10	19.1	19.8	43.2	32	40	3.2	3.8	32	27	8	24	2.5 ⁽⁵⁾	2

Type		Bearing rating (N)			Limit loads (N)		Life coefficients		Weight (g) ⁽³⁾
		Dynamic C _w ⁽⁴⁾	Static		radial F _r	axial F _a	X	Y	
			radial C _{or}	axial C _{oa}					
FR 22 AS	FRR 22 AS	700	415	105	470	210	1	0.593	32
FR 32-1 AS	FRR 32-1 AS	1 480	830	210	1 590	710	1	0.593	93
FR 40-1 AS	FRR 40-1 AS	2 440	1 300	325	4 040	1 790	1	0.593	169
FR 52-1 AS	FRR 52-1 AS	4 130	2 120	530	5 830	2 560	1	0.593	365

- 1) Housing bore tolerance H7
- 2) Safety thread SPIRALOCK
- 3) Weight without fittings
- 4) C_w basic load for 100 km
- 5) The guide rollers are completed with washer DIN 134
- 6) Pressure angle α for load calculation: 40°
- 7) Standard seals: material NBR, type RS
- 8) Length of screws: min = d+o+s; max = m+o+s

Guide Rollers **FR..AZ**

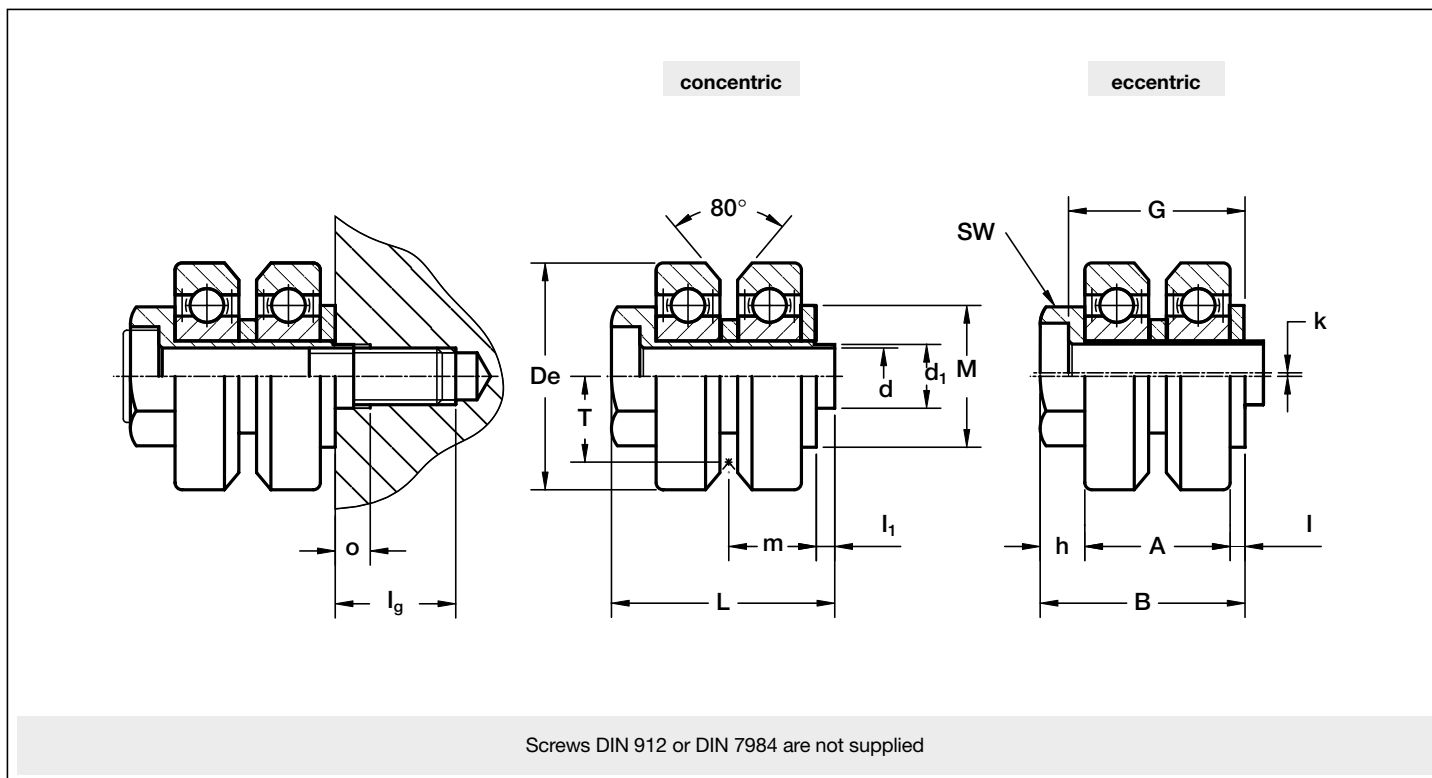

Type		Dimensions (mm)																
concentric	eccentric	De	d ₁ ⁽¹⁾	d	T	m	L	A	B	l ₁	l	h ⁽⁵⁾	M	SW	G	o	l _g ⁽²⁾	k
FR 22 AZ	FRR 22 AZ	22	6	5.1	8	9.2	23.5	13.9	21.5	2	2.2	5.4	14	10	18.5	4	13	0.5
FR 32 AZ	FRR 32 AZ	32	9	8.1	12.1	12.4	31.5	20.5	28.9	2.6	2.1	6.3	20	17	24.9	5	17	0.5
FR 40 AZ	FRR 40 AZ	40	13	12.1	14.6	15.5	39	25	36.5	2.5	3	8.5	25	24	30.5	5	26	1
FR 52 AZ	FRR 52 AZ	52	16	14.1	19.1	19.8	49.5	32	46.3	3.2	3.8	10.5	32	27	39.3	5.5	27	2

Type		Bearing rating (N)			Limit loads (N) shaft		Life coefficients		Weight (g) ⁽³⁾	Required screws e.g. DIN7984
		Dynamic	Static		radial F _r	axial F _a	X	Y		
		C _w ⁽⁴⁾	radial C _{or}	axial C _{oa}						
FR 22 AZ	FRR 22 AZ	700	415	105	470	210	1	0.593	30	M 5 x 30
FR 32 AZ	FRR 32 AZ	1 480	830	210	1 590	710	1	0.593	91	M 8 x 40
FR 40 AZ	FRR 40 AZ	2 440	1 300	325	4 040	1 790	1	0.593	169	M 12 x 50
FR 52 AZ	FRR 52 AZ	4 130	2 120	530	5 830	2 560	1	0.593	357	M 14 x 60

1) Housing bore tolerance: H7

2) Min. thread length for steel

Recommended screwed depth in steel = 1*d

In cast iron e.g. grey cast iron = 1.25*d

In aluminium = 2*d

3) Weight without screw

4) C_w basic load for 100 km

5) Dimension h plus screw head must be maintained free when using these guide rollers with FWS or FWH guide rails

6) Pressure angle α for load calculation: 40°

7) NBR seals RS type

Carriage T4FR

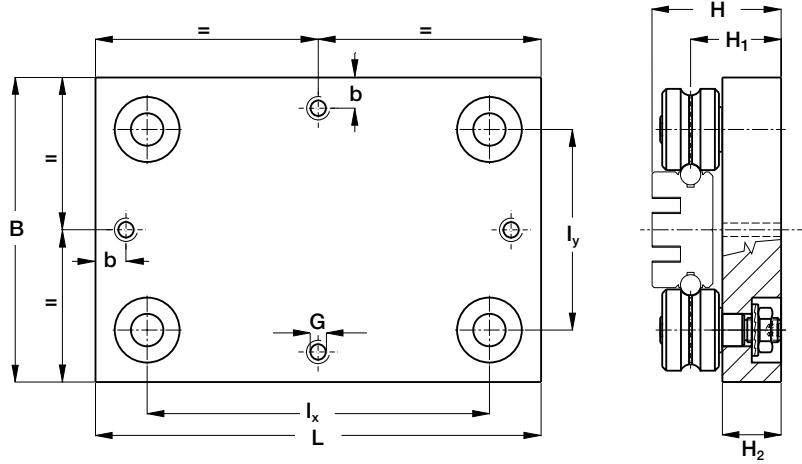

Type	Dimensions (mm)									Weight (kg)	Suggested combinations
	L	B	l_x	l_y	H	H_1	H_2	G	b		
T4FR 22 90	90	90	59	58.7	42.4	28.4	19	M6	15	0.6	FWS 22
T4FR 22 150	150	90	119	58.7	42.4	28.4	19	M6	15	0.9	FWS 22
T4FR 32 120	120	120	78	78	58.6	41.6	29	M8	15	1.5	FWS 32
T4FR 32 180	180	120	138	78	58.6	41.6	29	M8	15	2.1	FWS 32
T4FR 40 150	150	150	99	98.8	63.5	44.5	29	M8	15	2.6	FWS 40
T4FR 40 220	220	150	169	98.8	63.5	44.5	29	M8	15	3.4	FWS 40
T4FR 52 190	190	190	123	123	82.8	58.8	39	M10	20	5.4	FWS 52
T4FR 52 260	260	190	203	123	82.8	58.8	39	M10	20	6.8	FWS 52

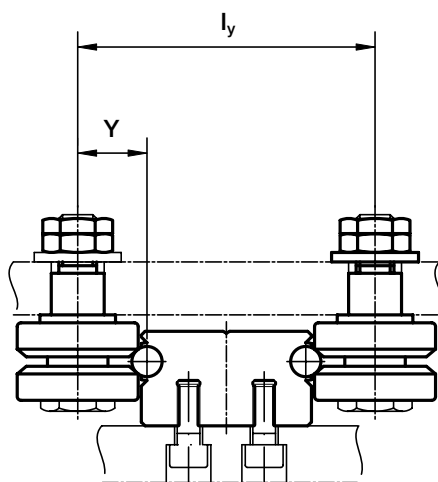

Type	Roller type FR/FRR, FR/FRR..AS/..AZ		Roller type FR/FRR...EI	
	Y	l_y	Y	l_y
FWS 22	12.7	59.4	12.4	58.8
FWS 32	18.3	78.6	18	78
FWS 40	22.4	98.8	22.4	98.8
FWS 52	28.4	122.8	28.4	122.8

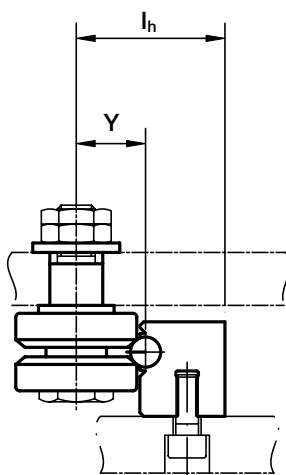

Type	Roller type FR/FRR, FR/FRR..AS/..AZ		Roller type FR/FRR...EI	
	Y	l_h	Y	l_h
FWH 22	12.7	29.7	12.4	29.4
FWH 32	18.3	39.3	18	39
FWH 40	22.4	49.4	22.4	49.4
FWH 52	28.4	61.4	28.4	61.4

The guide roller size has to match the rail size: i.e. guide roller FR32 with guide rails FW32

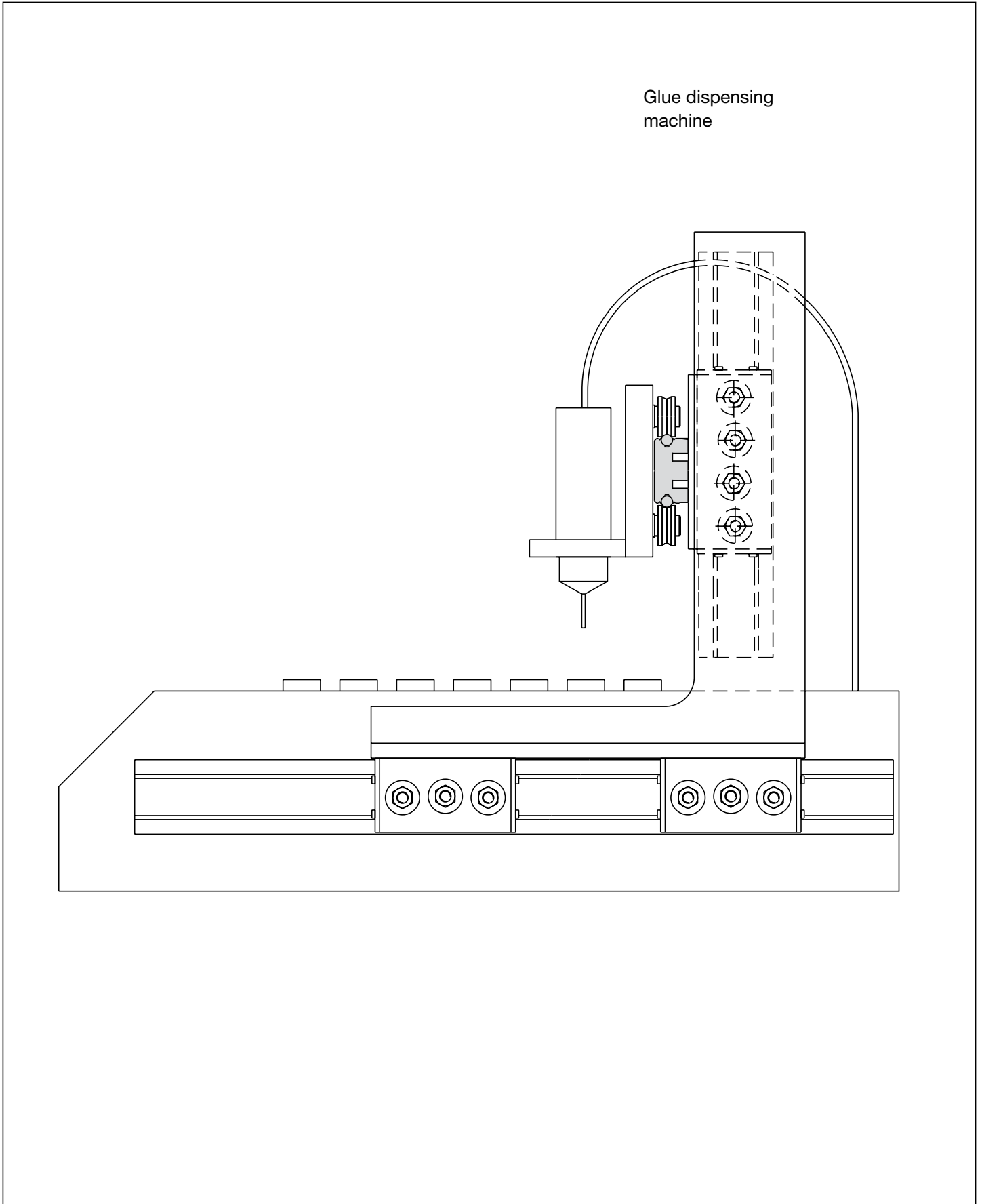

FWN system **NEW**



NADELLA

Guide rails **FWN** **NEW**



Dimensions according to DIN 645

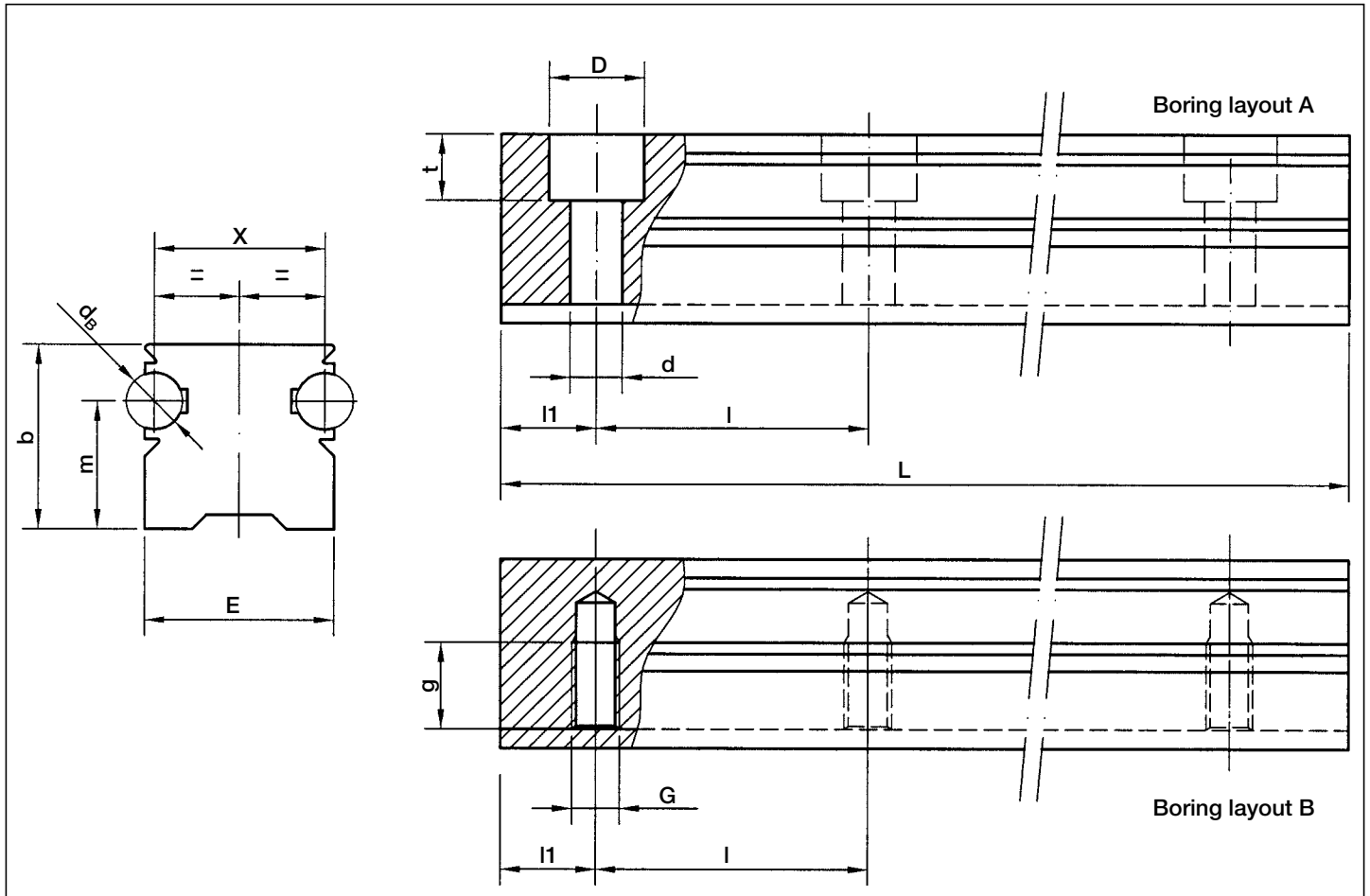

Type	Dimensions (mm)												Weight (kg/m)
	d_B	E	X	D	d	G	g	m	t	b	b	b	
FWN 20	6	20	18	10	5.5	M6	12	13.5	7	19.5	30	60	1.3
FWN 25	6	23	21	11	6.6	M6	12	18	8.5	25.5	30	60	1.8

Max length of single guide element L=4 500 mm (2)

1) Longer rails are supplied in sections with ground butt-joints

Hole layout

- holes according to DIN (A and B)
- finishes to drawing (NZ)
- without holes (NF)

Optional features

- ground one end (R)
- ground both ends (RR)
- stainless steel shafts (NX)

Carriage TA4 **NEW**



Dimensions according to DIN 645

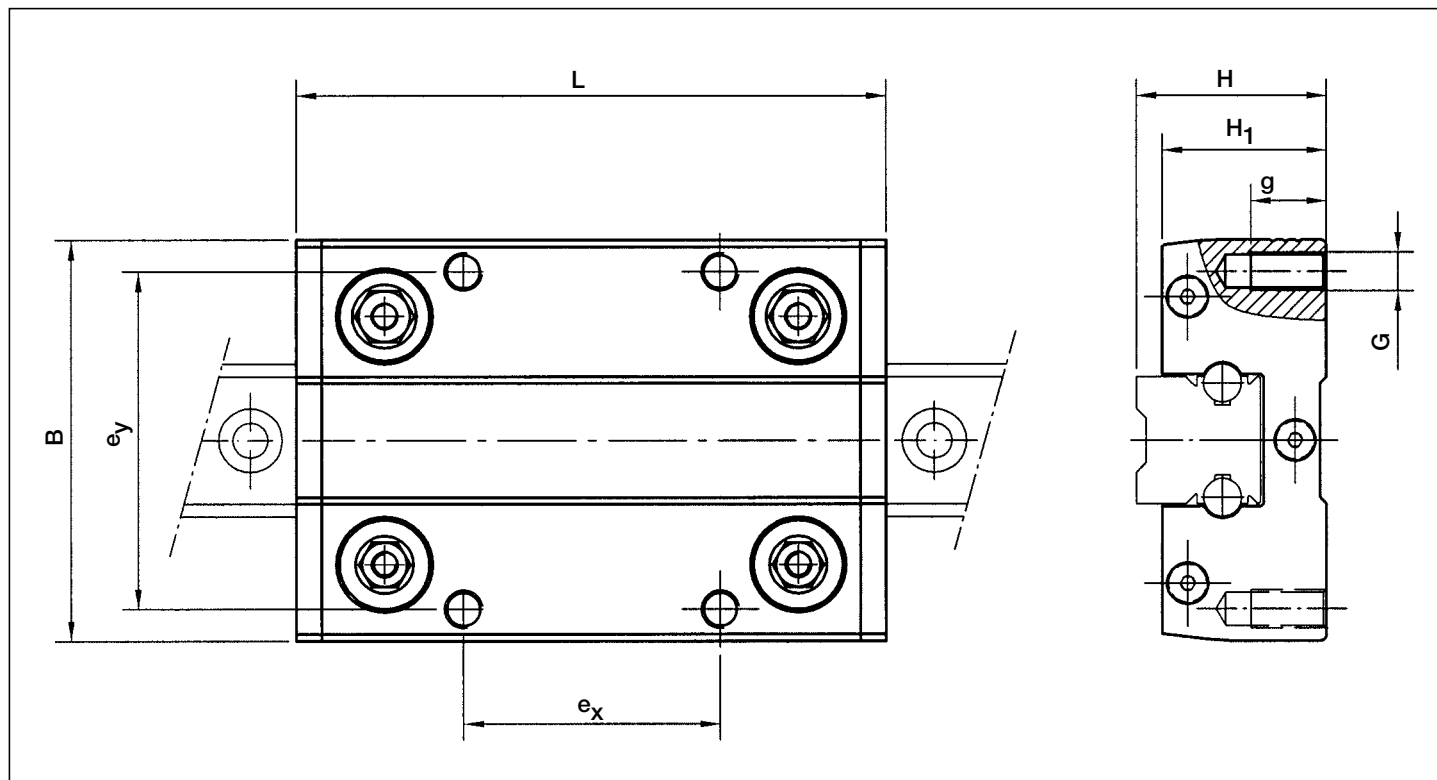

Type	Dimensions (mm)								Weight (kg)	Suggested combinations
	B	G	H	H ₁	L	e _x	e _y	g		
TA4GLA 17.06	63	M6	30	26	92	40	53	12	0.3	FWN 20
TA4GLA 19.06	70	M8	36	31	104	45	57	16	0.4	FWN 25

Max load on a single carriage

Carriage	F _y (N)	F _z (N)	M _x (Nm)	M _y (Nm)	M _z (Nm)
TA4GLA 17.06	600	400	5	15	20
TA4GLA 19.06	1 700	960	19	33	70

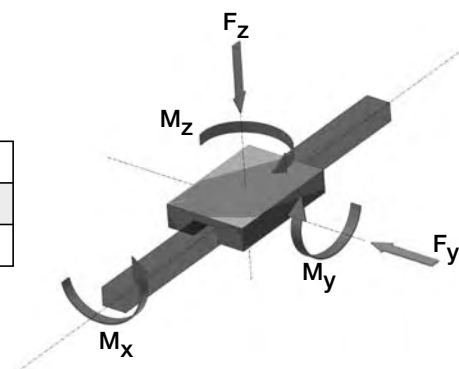

Optional features

- available with stainless steel guide rollers (**NX**)
- available with felts for lubrication (**UU**)

Carriage **TB4** NEW



Dimensions according to DIN 645

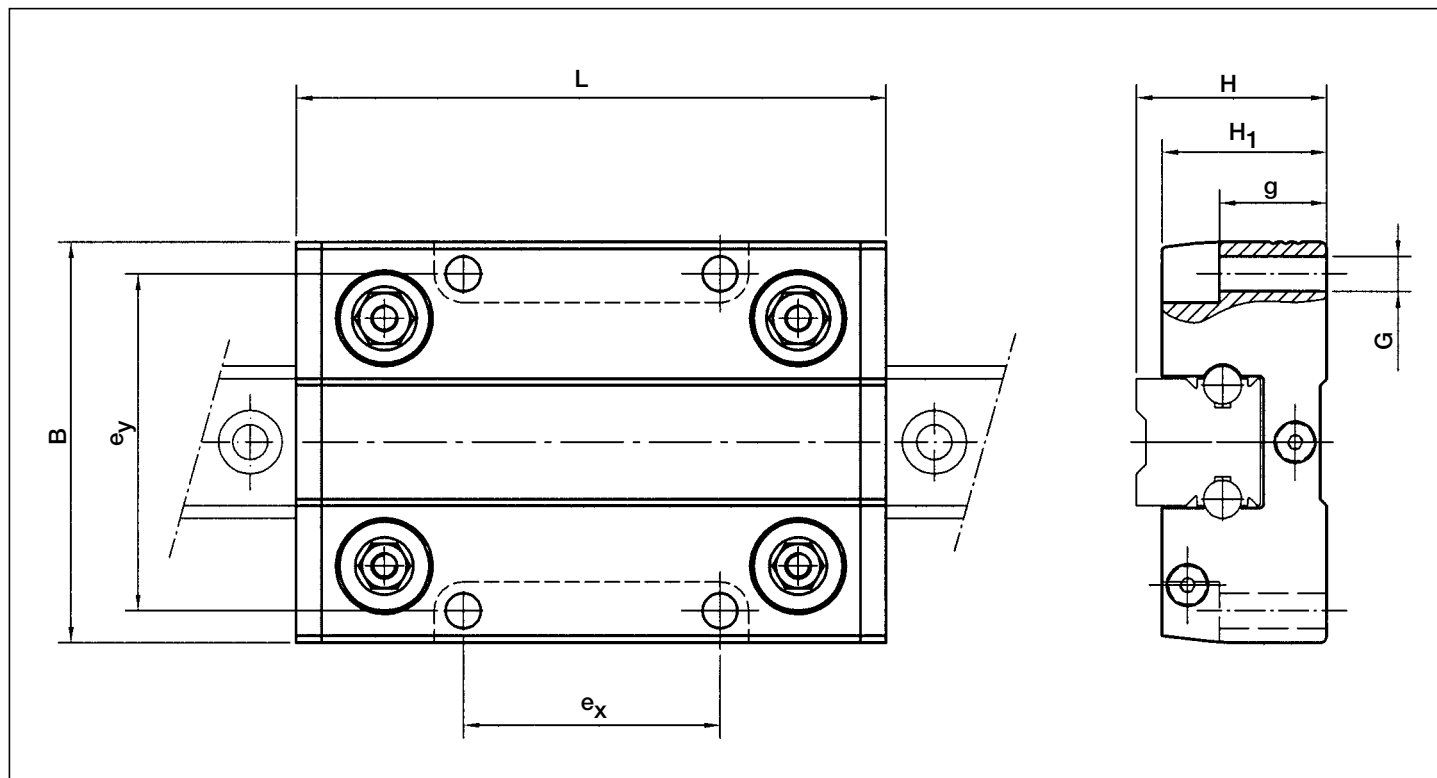

Type	Dimensions (mm)								Weight (kg)	Suggested combinations
	B	G	H	H ₁	L	e _x	e _y	g		
TB4GLA 17.06	63	5.5	30	26	92	40	53	17	0.25	FWN 20
TB4GLA 19.06	70	6.6	36	31	104	45	57	23.5	0.35	FWN 25

Max load on a single carriage

Carriage	F _y (N)	F _z (N)	M _x (Nm)	M _y (Nm)	M _z (Nm)
TB4GLA 17.06	600	400	5	15	20
TB4GLA 19.06	1 700	960	19	33	70

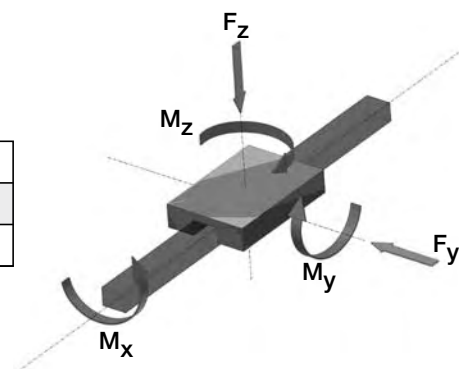

Optional features

- available with stainless steel guide rollers (**NX**)
- available with felts for lubrication (**UU**)

LM system



NADELLA

System

LM system is based on rail, guide rollers and carriages to provide a complete guiding system.

Guide rails and rollers can be used as single elements. In most cases the application is based on standard carriages and cursors.

Referring to the axis system below, the load capacities are tabulated as follows:

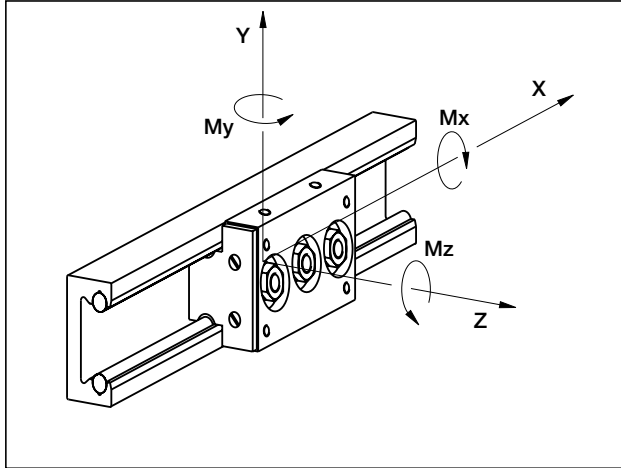

MAX LOAD ON SINGLE CARRIAGE

The following table shows the maximum load that can be applied on a single carriage.

Guide	Carriage	Fy N	Fz N	Mx Nm	My Nm	Mz Nm
LM 30	C3 RCL 17 06 065	1000*	330	3.5	5.8	10
	C4 RCL 17 06 085	1000	660	7	11	20
LM 40	C3 RCL 24 06 085	1810*	520	7.6	15	26
	C4 RCL 24 06 114	1810	1040	15	25	52
LM 65	C3 RCL 35 10 115	4160*	1200	26	45	78
	C4 RCL 35 10 152	4160	2400	50	75	155
LM 120	T4 RCL 35 10 150	4160	2400	110	120	200
	T4 RCL 35 10 220	4160	2400	110	200	350
	T4 RCP 42 10 150	5250	3030	140	150	260
	T4 RCP 42 10 220	5250	3030	140	250	440
LM 180	T4 PFV 43 22 180	6300	3120	185	200	400
	T4 PFV 43 22 280	6300	3120	185	350	715

* Fy directed to load the two concentric guide rollers

The maximum load is based on the guide roller data (stud and bearing strength) and on maximum contact pressure between rail and roller of 1250 N/mm². Loading is considered to be acting in a single plane or axis only.

BASIC DYNAMIC LOAD OF SINGLE CARRIAGE

The following table shows the nominal load that corresponds to a nominal life of the bearing at 100 km.

The nominal carriage life can be estimated from the standard bearing formula.

$$L_{10} = (C_i/P_i)^3 \times 100 \text{ km}$$

C_i and P_i are the basic capacity and load applied for a specific direction.

Guide	Carriage	Cy N	Cz N	CMx Nm	CMy Nm	CMz Nm
LM 30	C3 RCL 17 06 065	3000*	830	9	16	30
	C4 RCL 17 06 085	3000	1670	18	26	60
LM 40	C3 RCL 24 06 085	8400*	2340	34	67	122
	C4 RCL 24 06 114	8400	4670	68	110	244
LM 65	C3 RCL 35 10 115	15800*	4050	86	152	296
	C4 RCL 35 10 152	15800	8110	172	250	593
LM 120	T4 RCL 35 10 150	15800	8110	370	400	780
	T4 RCL 35 10 220	15800	8110	370	685	1335
	T4 RCP 42 10 150	24000	14130	650	700	1190
	T4 RCP 42 10 220	24000	14130	650	1195	2030
LM 180	T4 PFV 43 22 180	15190	5300	320	335	965
	T4 PFV 43 22 280	15190	5300	320	600	1725

* Fy directed to load the two concentric guide rollers

Calculation example: four carriages C3RCL 35 10 115 platform

The common configuration is shown in the here following sketch:

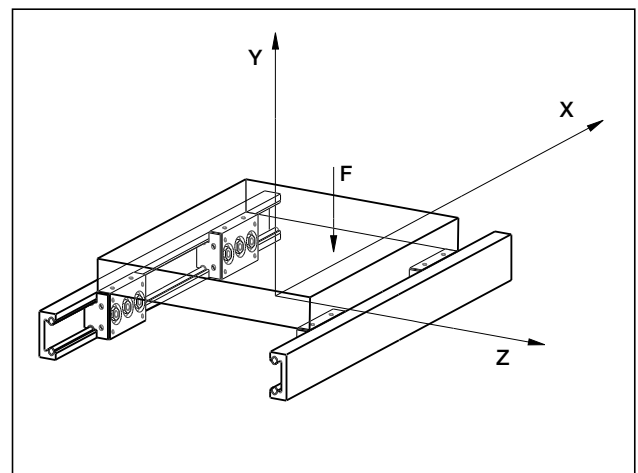

The platform moves along the two guide rails and has a load of "F" acting at 100 mm and 50 mm from the carriage centre.

Data:

guide LM 65 and cursors C3RCL3510115

$$I_x = 400 \text{ mm} \quad I_z = 300 \text{ mm}$$

$$F = 6.000 \text{ N} \quad X_F = 100 \text{ mm} \quad Z_F = 50 \text{ mm}$$

In this configuration the load on the most heavily loaded carriage is P_y and can be calculated using the following formula:

$$P = \frac{F}{4} + \frac{F \cdot X_F}{2 \cdot I_x} + \frac{F \cdot Z_F}{2 \cdot I_z} = 2750 \text{ N}$$

The load F_y shown in the "max loads" table is 4.160N (carriages mounted with eccentric roller on top), so the system is validated against breakage.

To estimate the system life we proceed as follows: from the nominal life table C_y = 15.800 N

$$L_{10} = (15.800/2.750)^3 \times 100 = 18.900 \text{ km}$$

Important note: to reach this value it is important to lubricate the rail, otherwise fretting corrosion between rail and roller can reduce the expected life.

Auto-aligning

Systems

Auto-aligning systems are assembled with guide rollers RAL type on LM system carriages tables.

The guide rollers RAL type allows axial displacement of the roller on the pin. An "O" ring retains the roller in position during the mounting.

Auto-aligning systems compensate for opposite rail misalignment errors. They are useful for mounting inaccurately aligned structures or those structures subject to flexure.

C3RAL C4RAL T4RAL

Is used to compensate for D_x misalignment between opposite rails. The table or carriage with all guide rollers RAL/RALR type can move towards or away from the rail. Type RAL provides radial support only. Axial load, transverse to the direction of travel, is reacted by carriage type RCL on the opposite rail.

C3RYL C4RYL T4RYL

Rail misalignment D_y requires the ability for both carriages to rotate. The table or carriage RYL type, with guide rollers RCL/RCP in contact with a steel shaft of the LM rail and guide rollers RALR type in contact with the opposite shaft, allows carriage rotation ensuring at the same time the transverse direction control.

The maximum D_y value is dependent on the distance between the rails and the tabulated maximum angle ' α ' for that carriage.

Note: RYL carriage axial load capability is lower than the same size RCL/RCP carriage.

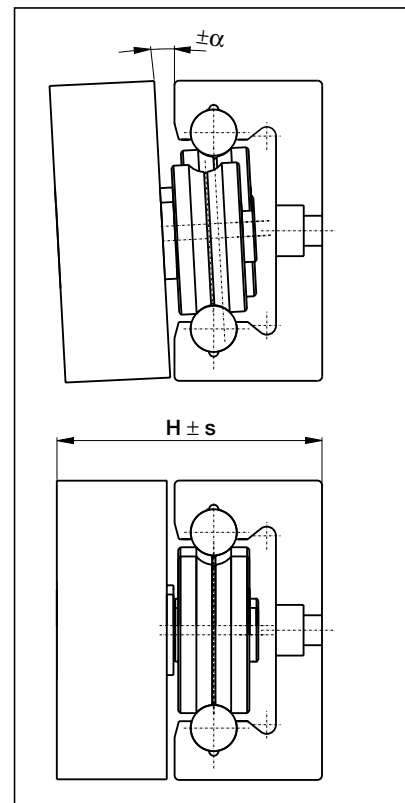
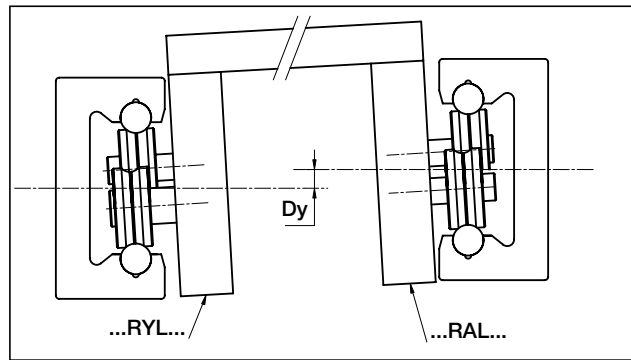
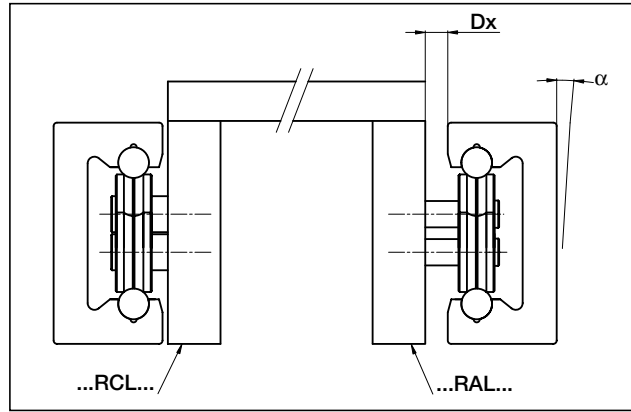
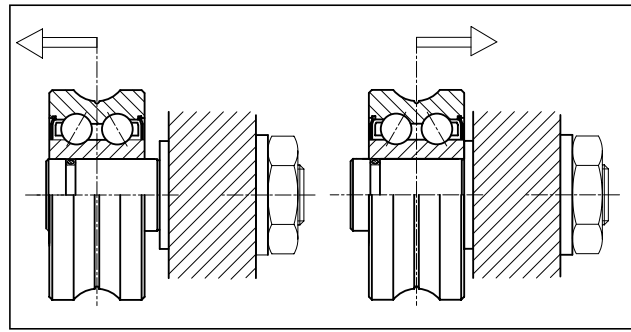

Max transverse moving allowed by auto-aligning tables and carriages

Carriage code (1)		α max (°)	S max (mm)	H nominal (mm)	Rail
C3RAL 17 06 065	C4RAL 17 06 085	1	0.8	27.5	LM 30
C3RYL 17 06 065	C4RYL 17 06 085	1	-		
C3RAL 24 06 085	C4RAL 24 06 114	1	1	35.7	LM 40
C3RYL 24 06 085	C4RYL 24 06 114	1	-		
C3RAL 35 10 115	C4RAL 35 10 152	1	1	58	LM 65
C3RYL 35 10 115	C4RYL 35 10 152	1	-		
T4RAL 35 10 150	T4RAL 35 10 220	0.3	1	58.5	LM 120
T4RYL 35 10 150	T4RYL 35 10 220	0.3	-		
T4RAL 42 10 150	T4RAL 42 10 220	0.75	1.5	65.5	
T4RYL 42 10 150	T4RYL 42 10 220	0.75	-		

1) See light load systems Nadella catalogue for table and carriage dimensions.
 2) Variations of dimension H exceeding $\pm s$ can compromise bearing axial moving and decrease the roller limit load, Fr.

Guide Rails LM



LM 30

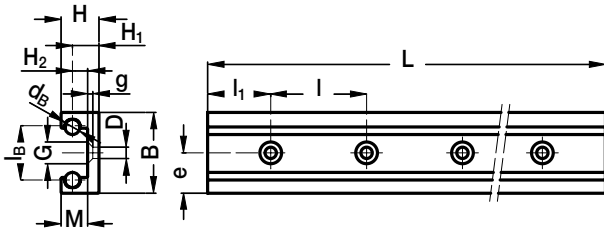

LM 40 LM 65

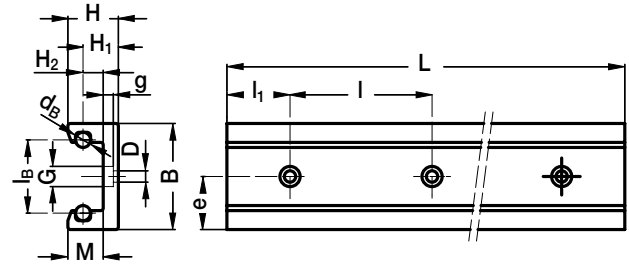

LM 120

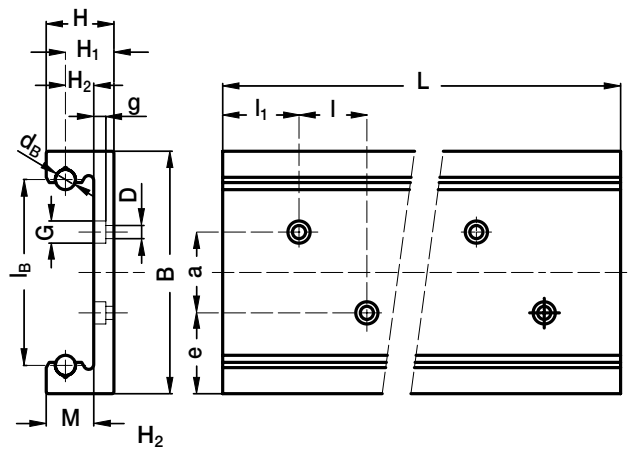

LM 180

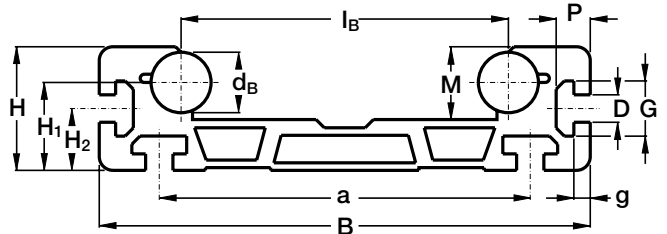

Type	Dimensions (mm)															Moments of inertia ⁽²⁾ (cm ⁴)		Weight (kg/m)	L ⁽¹⁾ max (mm)
	d _B	l _B	B	H	H ₁	H ₂	M	D	G	g	a	e	P	l	l ₁	J _x	J _y		
LM 30 ⁽⁴⁾	6	21.5	32	15.5	10.5	6	11	4.5	9.5	2.5	-	16	-	80	40	0.5	3	1.1	6 000
LM 40 ⁽⁴⁾	6	29	42	20	14	8	14	4.5	8	4	-	21	-	100	50	1.2	8.8	1.5	6 000
LM 65 ⁽⁴⁾	10	42.5	65	32	23.5	13.5	22	6.5	11	6	-	32.5	-	100	50	8.8	54.9	4.1	6 000
LM 120 ⁽⁴⁾	10	92	120	33.5	24	14	23.5	6.5	11	6	40	40	-	100	50	14.8	311.6	6	6 000
LM 180 ⁽³⁾	22	120	180	45	32	22.5	26.5	10	20.1	6	136	-	12.5	-	-	53.3	1 096.6	13.1	6 000

1) longer rails are supplied in sections with ground butt joints and, on request, with pin connection

2) Inertia value based on equivalent aluminium yield 70000 N/mm²

3) available with hollow shafts (AC)

4) available with stainless steel shafts (suffix NX)

Hole layout

- holes according to catalogue (**SB**)
- finishes to drawing (**NZ**)
- without holes (**NF**)

Optional features

- ground one end (**R**)
- ground both ends (**RR**)
- Chromium plated shafts (**CH**)
- Hollow shafts (**AC**) (3)

Example of standard designation: **LM 40/1720/NF**

See page 15 for standard codification

Guide Rollers **RCL, RCP, PFV**

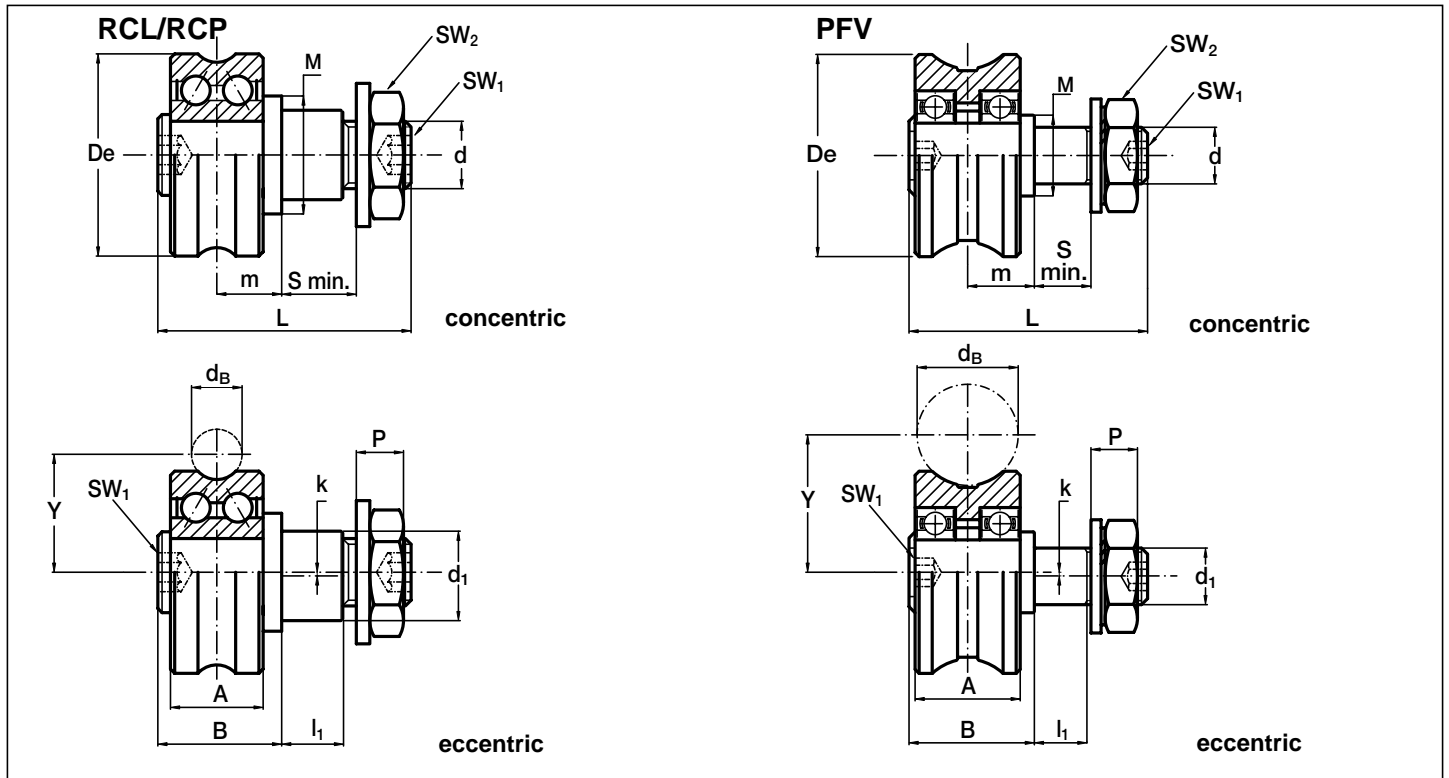

Type		Dimensions (mm)															Suggested combination		
concentric	eccentric	De	d _B	d ₁ ⁽¹⁾ conc.	d ₁ ⁽¹⁾ ecc.	d	Y	m	S min.	P	L	A	B	l ₁	M	SW ₁		SW ₂	k
RCL 17.06 ⁽³⁾	RCLR 17.06 ⁽³⁾	17	6	5	6.5	M 5x0.8	10.5	6	6	3.7	21	7	11	5.2	9	2.5	ch. 8	0.25	LM 30
RCL 24.06 ⁽³⁾	RCLR 24.06 ⁽³⁾	24	6	8	11	M 8x1.25	14	7.7	7	5.6	28.2	11	14.7	6.5	14	4	ch. 13	0.5	LM 40
RCL 35.10 ⁽³⁾	RCLR 35.10 ⁽³⁾	35	10	10	10	M10x1.25	20.65	10.5	14	7	43	15.9	20.5	13	18	5	ch. 17	0.75	LM 65
RCP 42.10	RCPR 42.10	42	10	17	17	M12x1.25	24	12.5	12	9.5	50	19	24.5	11	25	6	ch. 19	0.75	LM 120
PFV 43.22 ⁽³⁾	PFVR 43.22 ⁽³⁾	43	22	12	12	M12x1.5	29	14	13	12.5	52	23	27	12	18	5	ch. 19	1	LM 180

Type		Bearing rating (N)			Limit loads (N)		Life coefficients				Torque wrench ⁽²⁾ settings (Nm)	Weight (g)
		Dynamic	Static				Pa/Pr ≤ 0.37		Pa/Pr > 0.37			
			C _w ⁽⁴⁾	radial C _{or}	axial C _{oa}	radial F _r	axial F _a	X	Y	X		
RCL 17.06	RCLR 17.06	1 500	840	350	530	260	1	1.37	0.5	2.73	1.8	20
RCL 24.06	RCLR 24.06	4 200	2 300	1 000	1 600	830	1	1.37	0.5	2.73	8	40
RCL 35.10	RCLR 35.10	7 900	5 100	1 500	2 400	1 100	1	1.67	0.5	3.03	20	130
RCP 42.10	RCPR 42.10	12 000	7 100	2 100	4 300	1 160	1	1.17	0.5	2.53	24	185
PFV 43.22	PFVR 43.22	7 600	4 000	780	3 150	820	1	4	1	4	24	205

1) Housing bore tolerance: H7

2) The torque wrench settings are given for non-lubricated threads; for lubricated threads, multiply figure by 0.8

3) Available in stainless steel (suffix **NX**) with RS seals type

4) C_w basic load for 100 km

5) The guide rollers are complete with self-locking washers and hexagonal nut for fitting

6) Pressure angle α for load calculation: 60°

7) Standard seals ZZ type

Guide Rollers **RAL**

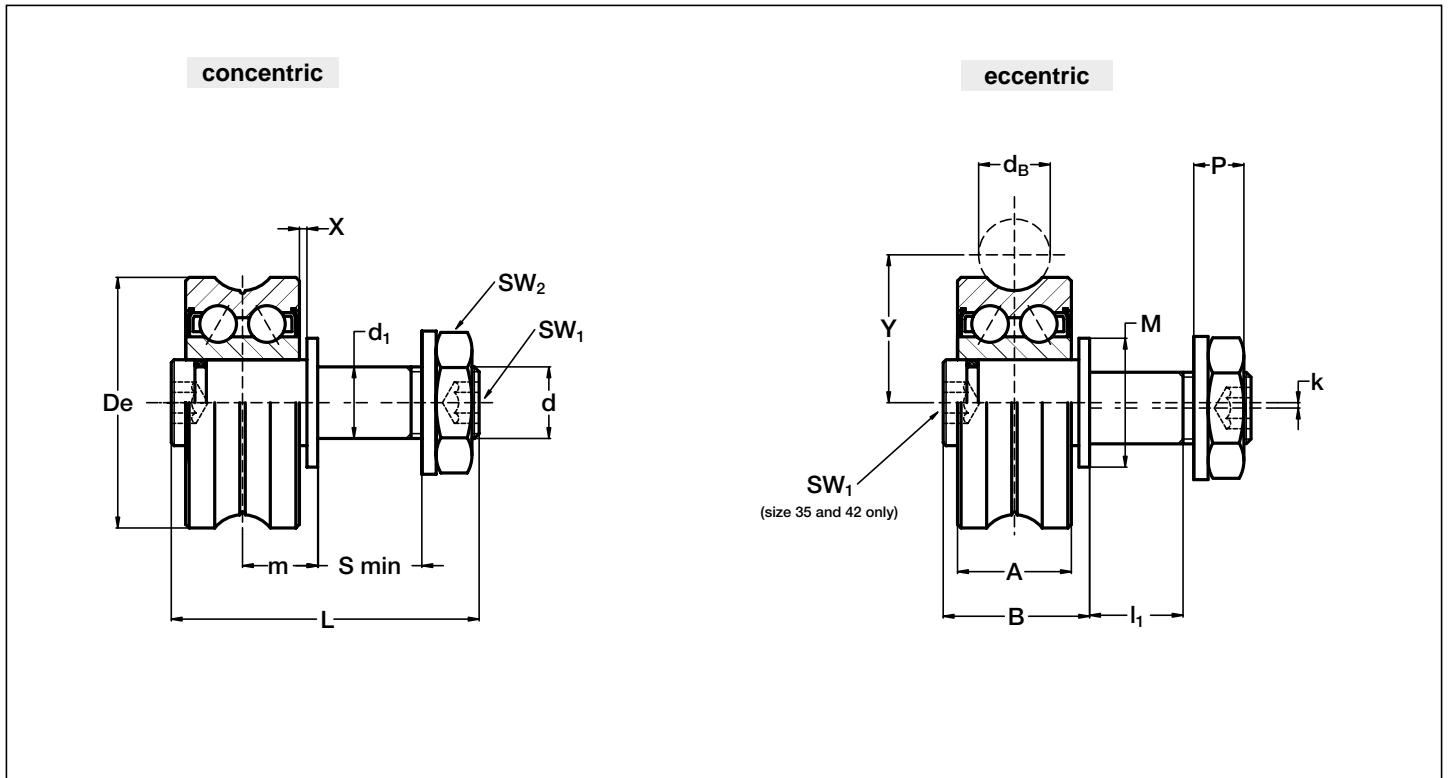

Type		Dimensions (mm)																		Suggested combination
concentric	eccentric	De	dB	d ₁ ⁽¹⁾ conc.	d ₁ ⁽¹⁾ ecc.	d	Y	m	S min.	P	L	A	B	X ⁽⁵⁾	I ₁	M	SW ₁	SW ₂	k	
RAL 17.06	RALR 17.06	17	6	5	6.5	M 5x0.8	10.5	6	6	3.7	20.5	7	10.5	0.8	5.5	9	2.5	ch. 8	0.25	LM 30
RAL 24.06	RALR 24.06	24	6	8	11	M 8x1.25	14	7.7	7	5.6	27.5	11	14	1	6.5	14	4	ch. 13	0.5	LM 40
RAL 35.10	RALR 35.10	35	10	10	10	M10x1.25	20.65	10.5	14	7	43	15.9	20.5	1	13	18	5	ch. 17	0.75	LM 65
RAL 42.10	RALR 42.10	42	10	17	17	M12x1.25	24	12.5	12	9.5	49	19	23.5	1.5	11	25	6	ch. 19	0.75	LM 120

Type		Bearing rating (N)		Limit loads (N) ⁽⁵⁾	Torque wrench ⁽²⁾ settings (Nm)	Weight (g)
		Dynamic	Static			
		C _w ⁽³⁾	radial C _{or}	radial F _r		
RAL 17.06	RALR 17.06	1 500	840	470	1.8	20
RAL 24.06	RALR 24.06	4 200	2 300	1 500	8	40
RAL 35.10	RALR 35.10	7 900	5 100	3 800	20	130
RAL 42.10	RALR 42.10	12 100	7 100	3 200	24	185

1) Housing bore tolerance: H7

2) The torque wrench settings are given for non-lubricated threads; for lubricated threads, multiply figure by 0.8

3) C_w basic load for 100 km

4) The guide rollers are complete with self-locking washers and hexagonal nut for fitting

5) Dimension ± X is the max displacement from dimension m to ensure proper guide roller function and safety

Guide Wheels **GLA**

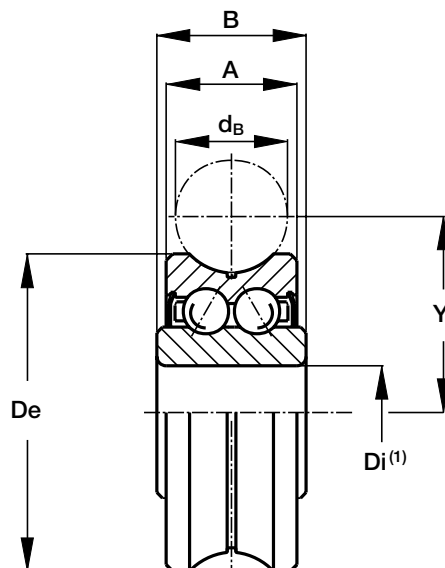

Type	Dimensions (mm)					
	De	dB	Di ⁽¹⁾	Y	A	B
GLA 17.06 ⁽⁴⁾	17	6	5	10.5	7	8
GLA 24.06 ⁽⁴⁾	24	6	8	14	11	11
GLA 35.10 ⁽⁴⁾	35	10	12	20.65	15.9	15.9
GLA 35.12	35	12	12	21.75	15.9	15.9
GLA 42.10	42	10	12	24	19	19
GLA 47.10	47	10	15	26.65	19	19
GLA 52.16	52	16	20	31.5	20.6	22.6

Type	Bearing rating (N)			Life coefficients				Weight (g)
	Dynamic C _w ⁽²⁾	Static		Pa/Pr ≤ 0.37		Pa/Pr > 0.37		
		radial C _{or}	axial C _{oa}	X	Y	X	Y	
GLA 17.06	1 500	840	350	1	1.37	0.5	2.73	10
GLA 24.06	4 200	2 300	1 000	1	1.37	0.5	2.73	20
GLA 35.10	7 900	5 100	1 500	1	1.67	0.5	3.03	80
GLA 35.12	7 800	5 000	1 400	1	2.47	0.5	3.83	80
GLA 42.10	12 000	7 100	2 100	1	1.17	0.5	2.53	100
GLA 47.10	15 400	9 200	3 300	1	0.97	0.5	2.33	170
GLA 52.16	19 300	10 500	4 000	1	2.17	0.5	3.53	230

1) Tolerance of Diameter Di: +0 / -0.008 mm

2) C_w basic load for 100 km

3) Pressure angle α for load calculation: 60°

4) Available in stainless steel (suffix NX) with RS seals type

5) Standard seals ZZ type

Carriage C3RCL, C3RAL, C3RYL

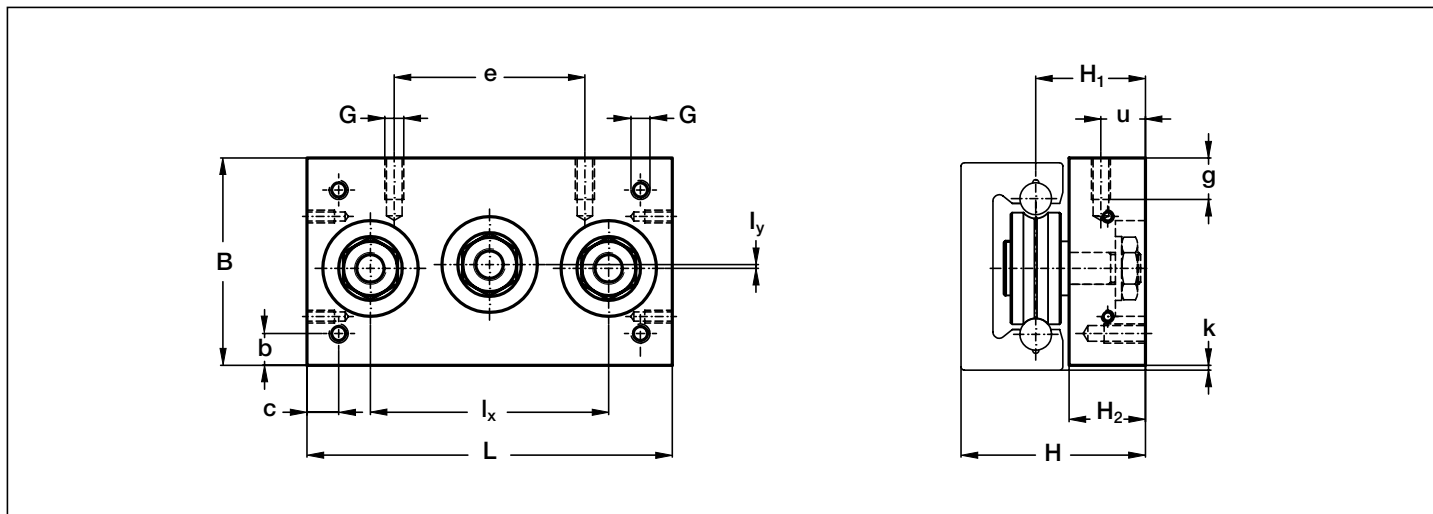

Type	Dimensions (mm)														Weight (kg)	Suggested combinations
	L	B	I _x	I _y	H	H ₁	H ₂	G	g	b	c	u	e	k		
C3RCL 17 06 065	65	32	40	0.5	27.5	17	11	M4	6	4	6	5.5	24	0.5	0.1	LM 30
C3RCL 24 06 085	85	42	58	1	35.7	21.7	14	M5	8	6	6	7	35	1	0.2	LM 40
C3RCL 35 10 115	115	65	75	1.2	58	34.5	24	M6	10	10	10	14	60	1.5	0.8	LM 65

1) Dimensions in the table are correct also for carriages C3 RAL, C3 RYL

2) Available with stainless steel guide rollers

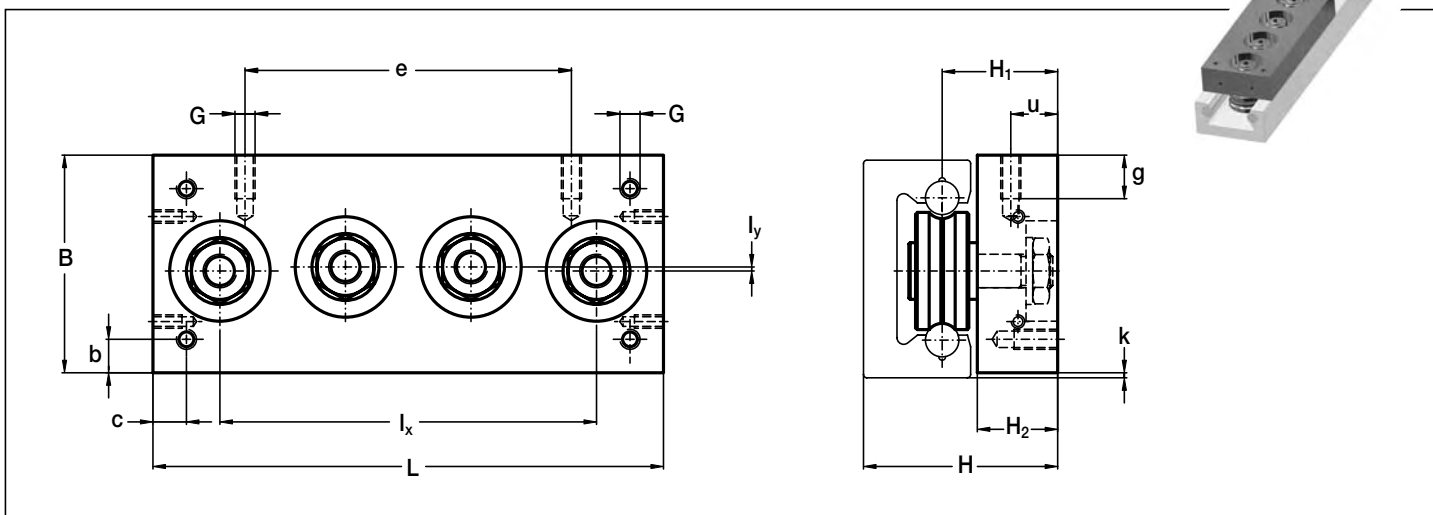

Type	Dimensions (mm)														Weight (kg)	Suggested combinations
	L	B	I _x	I _y	H	H ₁	H ₂	G	g	b	c	u	e	k		
C4RCL 17 06 085	85	32	60	0.5	27.5	17	11	M4	6	4	6	5.5	44	0.5	0.15	LM 30
C4RCL 24 06 114	114	42	87	1	35.7	21.7	14	M5	8	6	6	7	60	1	0.25	LM 40
C4RCL 35 10 152	152	65	112.5	1.2	58	34.5	24	M6	10	10	10	14	90	1.5	1	LM 65

1) Dimensions in the table are correct also for carriages C4 RAL and C4 RYL

2) Available with stainless steel guide rollers

Carriage **T4RCL, T4RCP, T4PFV** **T4RAL, T4RYL**

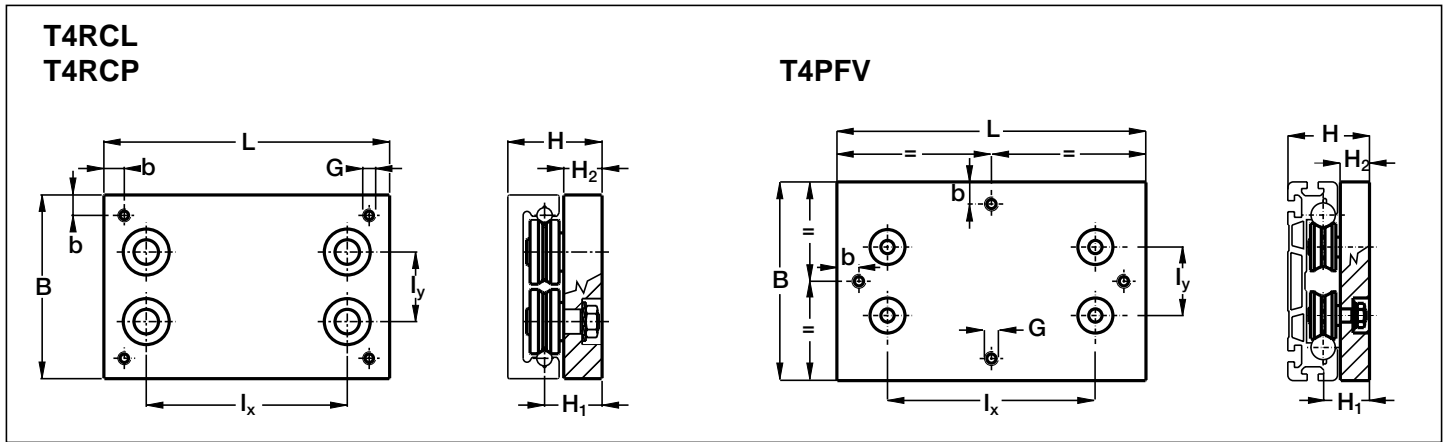

Type	Dimensions (mm)									Weight (kg)	Recommended pairing
	L	B	I _x	I _y	H	H ₁	H ₂	G	b		
T4RCL 35 10 150	150	120	99	50.7	58.5	34.5	24	M8	10	1.6	LM 120
T4RCL 35 10 220	220	120	169	50.7	58.5	34.5	24	M8	10	2.2	LM 120
T4RCP 42 10 150	150	120	99	44	65.5	41.5	29	M8	15	2	LM 120
T4RCP 42 10 220	220	120	169	44	65.5	41.5	29	M8	15	2.7	LM 120
T4PFV 43 22 180	180	180	127	62	74	42	28	M10	20	3.1	LM 180
T4PFV 43 22 280	280	180	227	62	74	42	28	M10	20	4.5	LM 180

1) Dimensions valid also for T4RAL and T4RYL

Lubricator **LUBM** **NEW**

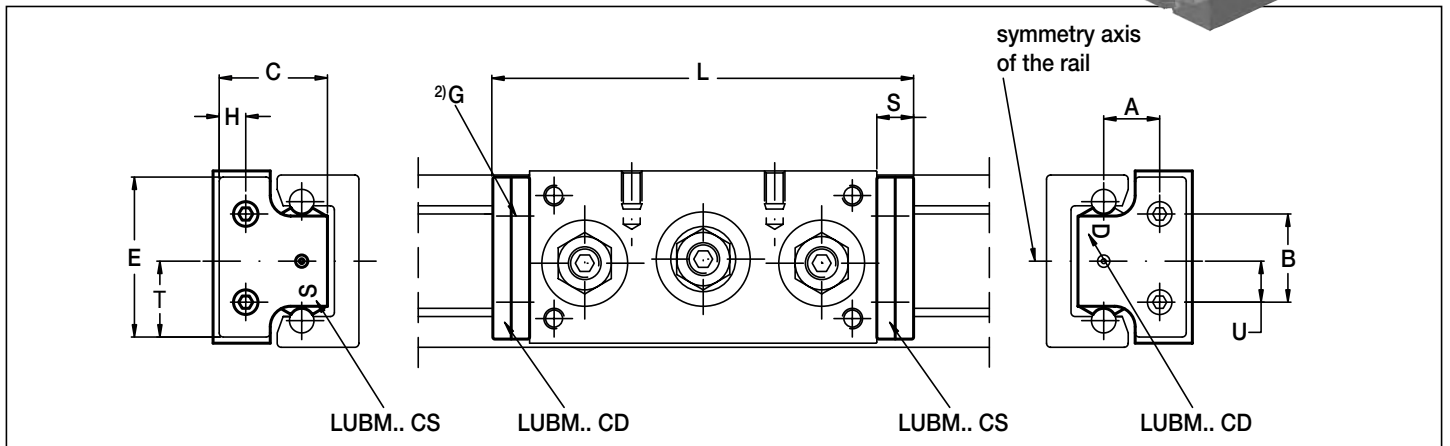
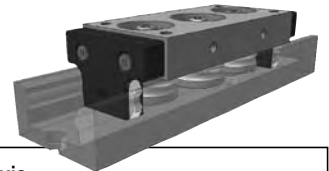

Type	Dimensions (mm)											Suggested combinations with the rails
	A	B	U	E	T	H	C	G	S	L C3 RCL C4 RCL		
LUBM 030	9.5	16	8	30	15	6.5	20.5	M2.5	9	83	103	LM 30
LUBM 040 CD/CS	13.7	21.5	10	40	19	7	27	M3	9	103	132	LM 40
LUBM 065 CD/CS	20.5	30	15	63	30	13	44.5	M4	9	133	170	LM 65

1) The lubricator is supplied with the felt already lubricated. The lubricant has a mineral oil base - 2) Countersunk head screws for the mounting are already in the packaging - 3) The lubricator can be mounted on carriages RCL, RAL and RYL

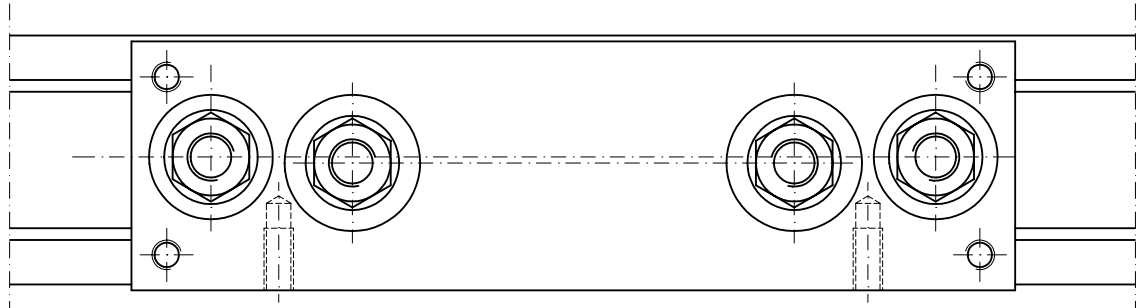

• Example of special design carriage

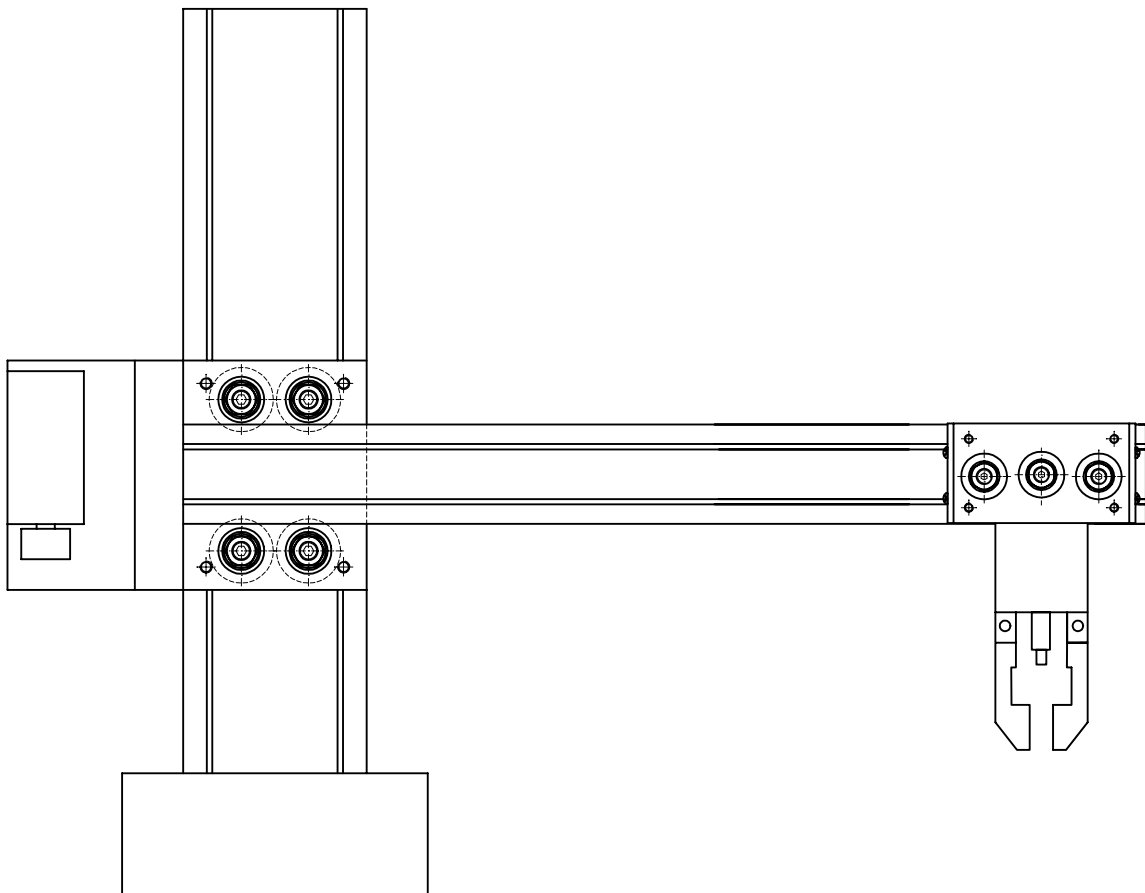

• Joystick for handling test samples

Product index (in alphabetic order)

Product	Description	Page
BL	Carriage with burnished body for the ROLBLOC system	29
C	Rail composed by an aluminium body and one shaft in steel, with a single raceway for C system	66
C3RAL	Carriage with body in anodised aluminium with three guide rollers type RAL for auto-aligning systems	96
C3RCL	Carriage with body in anodised aluminium with three guide rollers type RCL for LM system	96
C3RYL	Carriage with body in anodised aluminium with three guide rollers type (RCL and RAL) for auto-aligning systems	96
C4RAL	Carriage with body in anodised aluminium with four guide rollers type RAL for auto-aligning systems	96
C4RCL	Carriage with body in anodised aluminium with three guide rollers type RCL for auto-aligning systems	96
C4RYL	Carriage with body in anodised aluminium with three guide rollers type (RCL and RAL) for auto-aligning systems	96
DC	Rail composed by an aluminium body and two shafts in steel, with two raceways for DC system	65
FK	Guide wheel with tapered rollers bearings for GP system	57
FKU	Guide wheel with tapered rollers bearings for GU system	20
FKX	Guide wheel with tapered rollers bearings for FSX system	43
FKY	Guide wheel with tapered rollers bearings for FS and FSH systems	43
FR...AS	Guide roller with ball bearings for FWS and FWH systems	80
FR...AZ	Guide roller with ball bearings for FWS and FWH systems	81
FR	Guide roller with ball bearings for FWS and FWH systems	79
FR...EI	Guide roller with ball bearings for FS, FSH, FWS and FWH systems	39
FRLK...FRLR	Floating guide rollers with needle roller bearings for FS and FSH systems	41
FRN...EI	Guide roller with needle roller bearing for FS and FSH systems	40
FS...M	Guide rails in steel, with ground raceways, for FS systems	35
FS...MT	Guide rails in steel, with sandblasted raceways, for FS systems	34
FSB...MT	Guide rails in steel, with integrated support, with sandblasted raceways for FS systems	38
FSH...M	Guide rails in steel, with ground raceways, for FSH systems	37
FSH...MT	Guide rails in steel, with sandblasted raceways, for FSH systems	36
FSR...M	Circular guide rails in steel for FSR systems	51
FSX...M	Guide rails in steel, with ground raceways, for FSX systems	37
FSX...MT	Guide rails in steel, with sandblasted raceways, for FSX systems	36
FWH	Rail composed by an aluminium body and one shaft in steel, with one raceway for FWH systems	77
FWN	Rail composed by an aluminium body and two shafts in steel, with two raceways for FWN systems	86
FWS	Rail composed by an aluminium body and two shafts in steel, with two raceways for FWS systems	76
GC	Guide roller with needle roller bearings for GP system	58
GLA	Guide wheel with a double row of balls with oblique con contact, with "gothic arch" profile for LM systems	95
GP...M	Guide rail in steel, ground raceways	55
GP...MC	Guide rails in steel, rough ground raceways	54
GU...M	Guide rails, ground raceways for GU systems	27
GU...MT	Guide rails, sandblasted raceways for GU systems	27
LM	Rail composed by an aluminium body and two shafts in steel, with two raceways for LM system	92

Product index (in alphabetic order)

Product	Description	Page
LUBC	Lubricators for DC and C systems	72
LUBM	Lubricators for LM systems	97
LUBP	Lubricators for GP systems	60
LUBU	Lubricators for GU systems	21
LUBX, LUBY	Lubricators for FS systems	44/45
MBL	Carriage anodised aluminium body for the ROLBLOC system	28
NAID	Wipers for DC and C systems	71
PFV gothic profile	Guide rollers with “gothic arch” profile, based on ball bearings, with “gothic arch” profile for DC and LM systems	67
PFV straight profile	Guide rollers with straight profile, based on ball bearings for DC, C and LM systems	68
PK	Guide rollers with tapered roller bearings for GP systems	56
RAL	Floating guide rollers with “gothic arch” profile, with a double row of balls with oblique contact for LM systems	94
RCL	Guide rollers with “gothic arch” profile, with a double row of balls with oblique contact for LM systems	93
RCP	Guide rollers with “gothic arch” profile, with a double row of balls with oblique contact for LM systems	93
RKO	Guide rollers with tapered roller bearings with “gothic arch” profile	69
RKU	Guide rollers with tapered roller bearings for GU systems	19
RKX	Guide rollers with tapered roller bearings for FSX systems	42
RKY	Guide rollers with tapered roller bearings for FS and FSH systems	42
TA4, TB4	Carriages with anodised aluminium body with four guide rollers type GLA for FWN systems	87-88
T4FR	Carriages with anodised aluminium body with four guide rollers type FR..EI for FWS systems	82
T4PFV	Carriages with anodised aluminium body with four guide rollers type PFV for DC, C and LM systems	70
T4RAL	Carriages with anodised aluminium body with four guide rollers type RLA for LM systems	97
T4RCL	Carriages with anodised aluminium body with four guide rollers type RCL for LM systems	97
T4RCP	Carriages with anodised aluminium body with four guide rollers type RCP for LM systems	97
T4RYL	Carriages with anodised aluminium body with four guide rollers type RCP or RCL or RAL for LM systems	97

Suffix index (in alphabetic order)

AC	Hollow shafts
CH	Chromium plated shafts
M	Ground profile
MC	Rough ground profile
MT	Sandblasted profile
NF	Rails without holes
NX	Stainless steel version for guide rollers or guide rails
NW	Chemical Nickel-plating
NZ	Finishes to drawing
R	Ground one end
RR	Ground both ends
SB	Holes according to catalogue
UU	Felts for lubrication available

3D CAD DRAWINGS



*Our 2D and 3D drawings can be
down loaded from our web site:*

www.nadella.it

Nadella S.p.A.

Direzione Generale

Via Melette, 16
20128 Milano

Tel. +39 02.27.093.297
Fax +39 02.25.51.768
Fax +39 02.25.76.479

<http://www.nadella.it>

e-mail: customer.service@nadella.it

Stabilimento e Magazzino

Concorezzo (MI) Via del Lavoro, 7/9
20049 Concorezzo (MI)

Filiale

Bologna

Via A. Saffi, 22/2
40131 Bologna

Tel. +39 051.52.64.11
Fax +39 051.55.52.68

Organizzazione Commerciale

Ancona

Bergamo

Firenze

Padova

Pordenone

Torino

Nadella GmbH

Nufringen

Rudolf-Diesel-Straße 28
71154 Nufringen
<http://www.nadella.de>

AUSTRIA

TAT Technom Antriebstechnik GmbH

Haidbachstraße 1
4061 Pasching
Tel. +43 7229 648 400
Fax +43 7229 618 17
www.tat.at

CHINA

WENXIN Machinery

Guang Zhou Rou
Rm2001 20F JUNLIN Int. Plaza
Tel. +86 25 51 86 01 21
Fax +86 25 51 86 01 26
www.wenxinmachinery.com

CZECH REPUBLIC

TAT pohonova technika spol s.r.o.

Hranicni 53
37006 Ceske Budejovice
Tel. +420 387 414 414
Fax +420 387 414 415
www.tat.at/cz

DENMARK

ACTON A/S

Torbenfeldvej 3
2665 Vallensbaek
Tel. +45 43 73 70 43
Fax +45 86 75 27 00
www.acton.dk

FINLAND

EIE Maskin Oy

Postfach PL 80
10601 Tammissaari
Tel. +358 19 223 91 00
Fax +358 19 223 91 99
www.eie.se

FRANCE

SNR Lyon - Direction Réseau France

Le Florentin - B.P. 8
71, Chemin du Moulin Carron
Tel. +33 478 66 6800
Fax +33 478 66 6820
www.snr.bearings.fr

INDIA

NRB Bearings

Dhannur, 15 Sir P.M. Road, Fort,
Mumbai 400 001
Tel. +91 022 22 66 41 60
Fax +91 022 22 66 04 12
www.nrbbearings.com

KOREA

Intech Automation Inc.

Youngdeungpodong 7-GA
13FL, JEIL Bldg., 94-46
Seoul, Korea 150-037
Tel. +822 26 32 770
Fax +822 34 39 00 80
www.intechautomation.co.kr

NETHERLANDS

LinMotion BV

Kruisboog 2
3905 CV TG Veenendaal
Tel. +31 318 694 226
Fax +31 318 694 225
www.linmotion.nl

NORWAY

Elmeko AS

Postboks 80
1346 Gjettem
Tel. +47 675 72 270
Fax +47 675 72 280
www.eie.se

POLAND

ENITRA Sp.zo.o

ul. 1-go Maja 62 - 58300 Walbrzych
Tel. +48 74887 02 24
Fax +48 74887 02 23
www.enitra.pl

SPAIN

GAES S.A.

Paseo Ubarburu, 58 Poligono 27
20014 - San Sebastián
Tel. +34 943 445 777
Fax +34 943 445 350
www.gaessa.com

RODALSA S.L.

Barrachi, 12 - Pab. 21 - 01013 - Vitoria
Tel. +34 945 289 395
Fax +34 945 289 246
www.rodalsa.net

SWEDEN

EIE Maskin AB

Harpundswägen 197
12459 Bandhagen
Tel. +46 8 727 88 00
Fax +46 8 727 88 99
www.eie.se

SWITZERLAND

Uiker Wälzlager AG

Schwerzistrasse 30 - 8807 Freienbach
Tel. +41 554 15 18 68
Fax +41 554 15 18 60
www.uiker.ch

TURKEY

EKSİM Mühendislik Sistemleri

Perpa Ticaret Merkezi B Blok Kat: 11 No: 1675
Sisli - Istanbul / Turkey
Tel. +90 212 222 81 12
Fax +90 212 222 81 02
www.eksimmuhendislik.com

