

isel®

From Components to Systems

Spindle Motors

iSA Series and Accessories



Catalogue 2010/1

Who we are



Eiterfeld (Hessia) factory sized approx. 8,000 m² production, warehouse and office space



Dermbach (Thuringia) factory sized approx. 14,000 m² production, warehouse and office space



Eiterfeld (Hessia) factory sized approx. 8,000 m² production, warehouse and office space

The company **isel Germany AG** founded 1972 in Eiterfeld (Hessia) under the company name isert-Elektronik is the core company of the isel group of companies.

The company objective are the development, production, sales and service of components and systems for automation.

The product range from components to systems made by isel includes CNC units, CNC machines, automation, handling and robotics with step, servo, linear, and torque motors including controls.

The company isel Germany AG has locations in Germany in. Eichenzell (Hessia), Eiterfeld (Hessia) and Dermbach (Thuringia) with a total of 33,000 m² of production, warehouse and office space.

Company objectives

The objective of isel Germany AG is to provide products and services at a favourable cost/performance ratio and a high level of quality.

The division industrial automation is covered by isel Germany AG with development, production, sales and service in addition to consultation, training and project planning.

The modular alignment of isel components for the fields of ELECTRONICS, MECHANICS, SOFTWARE and SYSTEMS form an important role. Open interfaces of the CNC controls used in addition to software allow flexibility for customer-oriented customisations. The business field also includes remittance work and project planning for OEM customers in all fields.

Introduction

„isel spindle motors are eminently suited for applications in non-metal, aluminium, plastic and wood processing.“

In developing our spindle motors, we place a great deal of importance on **functionality, quality and optimum pricing**. In addition, our spindle motors are **particularly easy to maintain**.

Series arrangements with minimum spacing can be realized through the **slim design** and the **square cross-section of the housing**.

In terms of the electrical construction, our motors have **three-phase squirrel cage motors with 2-pole windings, laid out according to DIN EN 60034**. The insulating material of the windings is manufactured according to Insulation Class F.

The motors are **finely balanced dynamically**, so that **good running characteristics** are attained even at high speeds. They cover a speed range of **3,000 to 30,000 rpm** overall.

All spindle motors are **completely manufactured in Germany**, fulfil the minimum requirements of **Protection Class IP54** and are therefore also permitted for the wood dust area I wonder if this should be the “woodpulp industry” or “wood dust areas”.

In our product range, you will find not only the spindle motors themselves, but also all required **cables in different lengths and preset, reliable frequency converters** for the controller connection.

We are an easy-to-use service in comparison to many of our competitors and possess our own year-round repair service, due to the integration **under one roof of our development, production, sales and service departments**.

Our product palette is completed by **comprehensive accessories**, such as dust collectors, minimum quantities - lubrication technology, collet chucks (Swiss quality), SK-collets, tool changers and our unique, patented CoolMin system for optimum and economic mould cooling without residue.



Content Overview

iSA 500	with manual tool changer	Page 6
iSA 750	with manual tool changer	Page 8
iSA 1500	with manual tool changer	Page 10
iSA 900	with automatic tool changer	Page 12
iSA 2200	with automatic tool changer	Page 14
iSA 3600	with automatic tool changer	Page 16
UFM 500 // UFM 1050	Universal milling spindles	Page 18
CoolMin	Mould cooling	Page 20
Tool changer // Tool holders	SK 11, SK 20, SK 30	Page 22
Frequency converter	SKC 750 / 1500 / 4000	Page 24
Accessories	Dust extractor, power cord, length measuring probe, collets	Page 26

Spindle Motors

iSA 500



Illustration:
iSA 500



Illustration: iSA 500
with CoolMin internal

Optional:

- CoolMin tool and material cooling, internally or externally
- Frequency converter
- Collets

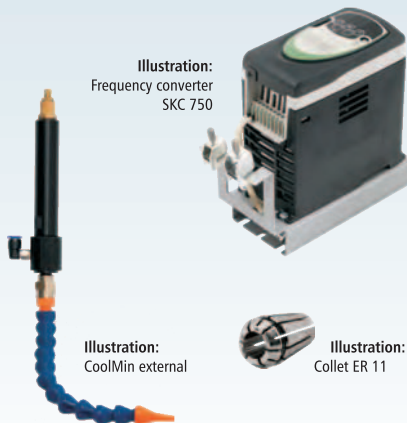

Illustration:
Frequency converter
SKC 750

Illustration:
CoolMin external

Illustration:
Collet ER 11

- Robust 2-pole three-phase motor
- Protection Class IP54, Insulation Class F
- Motor shaft for ER 11 collets
- Cast bearing bracket A side, aluminium die casting B side
- Nominal power output 0.5 kW (S6-40% operation)
- Speed range 5,000 rpm — 30,000 rpm
- Torque 0.28 Nm (at 18,000 rpm)
- Nominal voltage 230 V
- Manual tool change
- Clamping range \varnothing 1 mm – \varnothing 7.0 mm
- Self-ventilation B side
- Speed control by means of frequency converter
- Spindle bearing: 2 ball bearings A side (milling side)
 1 bearing B side (fan side)
- Concentricity: 0.01 mm
- Weight: 2.8 kg

Technical Data

Torque with nominal speed (18,000 rpm)	Nm	0.28
Speed range	rpm	5,000 ... 30,000
Cut-off frequency	Hz	300
Pole number		2
Nominal voltage	V	230
Nominal current	A	2.6
Cos Φ		0.75
Nominal capacity (S6 = 40% operation)	W	500
Concentricity	mm	0.01
Weight	kg	2.8

Torque Curve

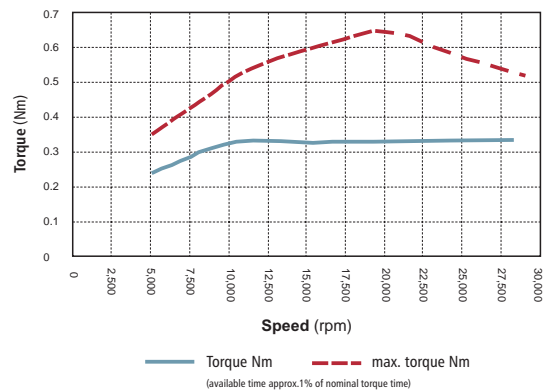

Dimensions

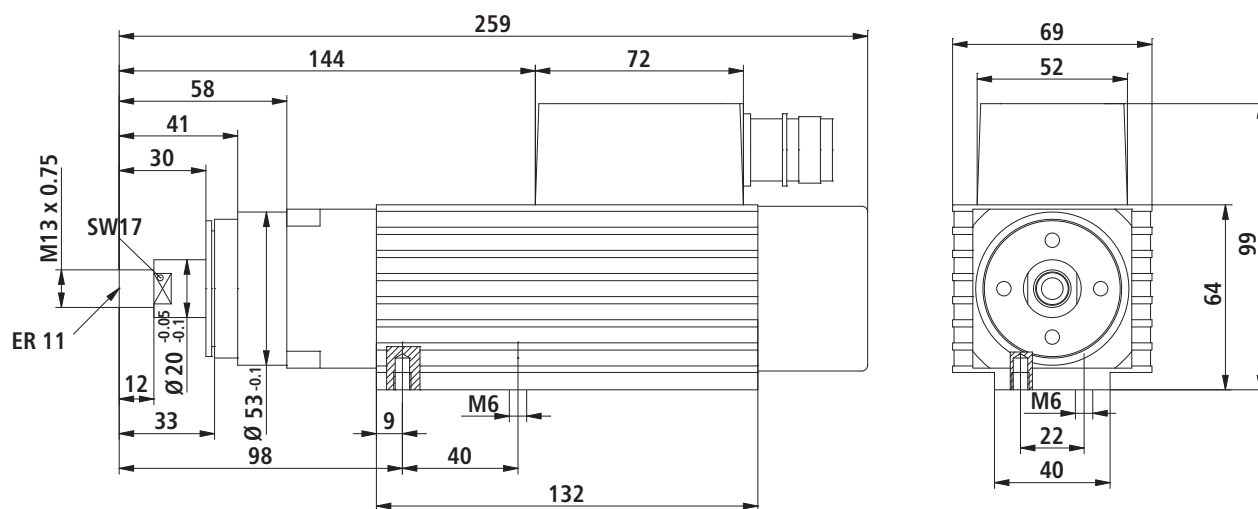

Ordering Information

Item name		Item number
iSA 500	with collet ER 11 (6 mm), chuck key ER 11, spanner SW 17, Interconnectron connector	477004 3130
iSA 500 with converter	with collet ER 11 (6 mm), chuck key ER 11, spanner SW 17, Interconnectron connector, connecting cable 8 m	310704 1611
iSA 500 with CoolMin (internal)	with collet ER 11 (6 mm), chuck key ER 11, spanner SW 17, Interconnectron connector	477004 5130
iSA 500 with converter + CoolMin (internal)	with collet ER 11 (6 mm), chuck key ER 11, spanner SW 17, Interconnectron connector, connecting cable 8 m	310704 1631
Collet set ER 11	1.0 / 1.5 / 2.0 / 2.5 / 3.0 / 3.5 / 4.0 / 4.5 / 5.0 / 5.5 / 6.0 / 6.5 / 7.0 mm	239170 0001
Exhaust device for EuroMod / FlatCom	prepared for \varnothing 38 mm hose	239012 0000
Exhaust device for ICP / ICV 4030	prepared for \varnothing 21 mm hose	280210 9001
	prepared for cold air nozzle / CoolMin external	280211 9001
Mounting panels for isel Systems (Z axis)	EuroMod / FlatCom (LES 21)	277028
	ICP / ICV 4030	280000 0046
	Linear unit LES 5	277014
	Linear unit LES 6	277028 0008

Spindle Motors

iSA 750



Illustration: iSA 750



Illustration: iSA 750
with CoolMin internal

Optional:

- CoolMin tool and material cooling, internally or externally
- Frequency converter
- Collets

- Robust 2-pole three-phase motor
- Protection Class IP54, Insulation Class F
- Motor shaft for ER 16 collets
- Aluminium die cast bearing bracket A and B side
- Nominal power output 0.75 kW (S6-40% operation)
- Speed range 3,000 rpm — 24,000 rpm
- Torque 0.34 Nm (at 22,000 rpm)
- Nominal voltage 230 V
- Manual tool change
- Clamping range \varnothing 1 mm – \varnothing 10 mm
- Self-ventilation B side
- Speed control by means of frequency converter
- Dual precision bearing
- Concentricity: 0.01 mm
- Weight: 2.6 kg

Illustration:
Frequency converter
SKC 750



Illustration:
Collet ER 16



Illustration:
CoolMin external



Technical Data

Torque with nominal speed (22,000 rpm)	Nm	0.34
Speed range	rpm	3,000 ... 24,000
Cut-off frequency	Hz	300
Pole number		2
Nominal voltage	V	230
Nominal current	A	3.4
Cos Φ		0.79
Nominal capacity (S6 = 40% operation)	W	750
Concentricity	mm	0.01
Weight	kg	2.6

Torque Curve

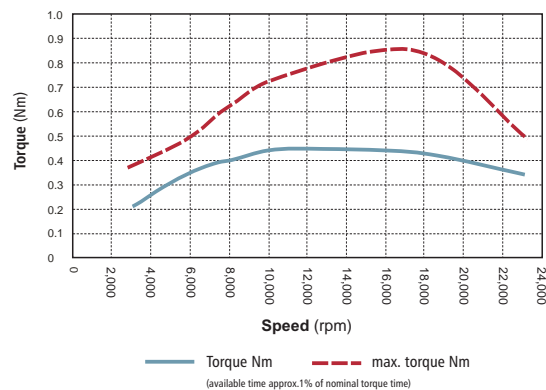

Dimensions

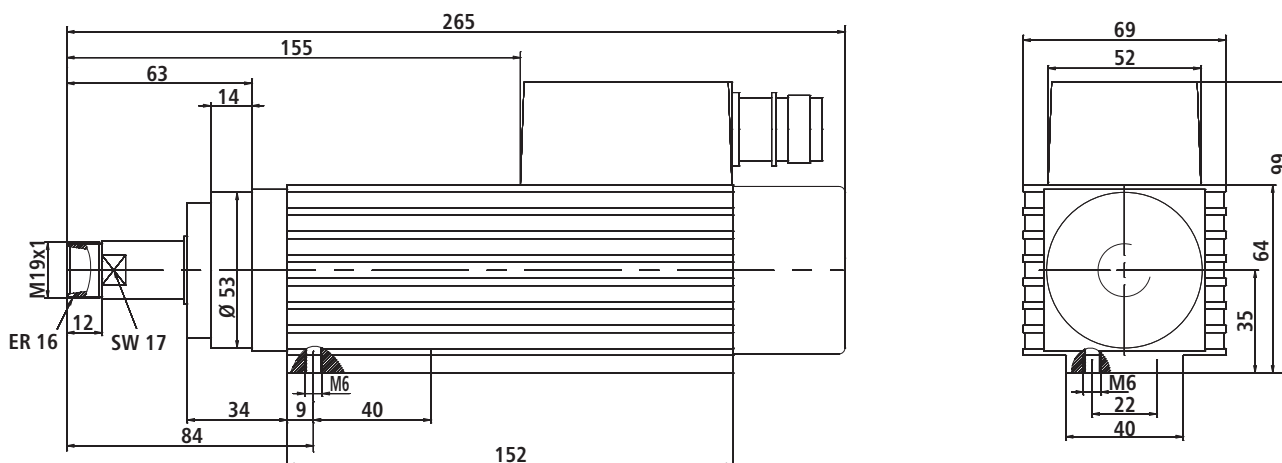

Ordering Information

Item name		Item number
iSA 750	with collet ER 16 (6 mm), chuck key ER 16, spanner SW 17, Interconnectron connector	477008 3124
iSA 750 with converter	with collet ER 16 (6 mm), chuck key ER 16, spanner SW 17, Interconnectron connector, connecting cable 8 m	310708 1611
iSA 750 with CoolMin (internal)	with collet ER 16 (6 mm), chuck key ER 16, spanner SW 17, Interconnectron connector	477008 5124
iSA 750 with converter + CoolMin (internal)	with collet ER 16 (6 mm), chuck key ER 16, spanner SW 17, Interconnectron connector, connecting cable 8 m	310707 1631
Collet set ER 16	1.0 / 2.0 / 3.0 / 4.0 / 5.0 / 6.0 / 7.0 / 8.0 / 9.0 / 10.0 mm	239171 0001
Exhaust device for EuroMod / FlatCom	prepared for \varnothing 38 mm hose	239012 0000
Exhaust device for ICP / ICV 4030	prepared for \varnothing 38 mm hose	280210 9001
Exhaust device for ICP / ICV 4030	prepared for \varnothing 21 mm, with cold air nozzle	280211 9001
Mounting panels for isel Systems (Z axis)	EuroMod / FlatCom (LES 21)	277028
	ICP / ICV 4030	280000 0046
	Linear unit LES 5	277014
	Linear unit LES 6	277028 0008

Spindle Motors

iSA 1500

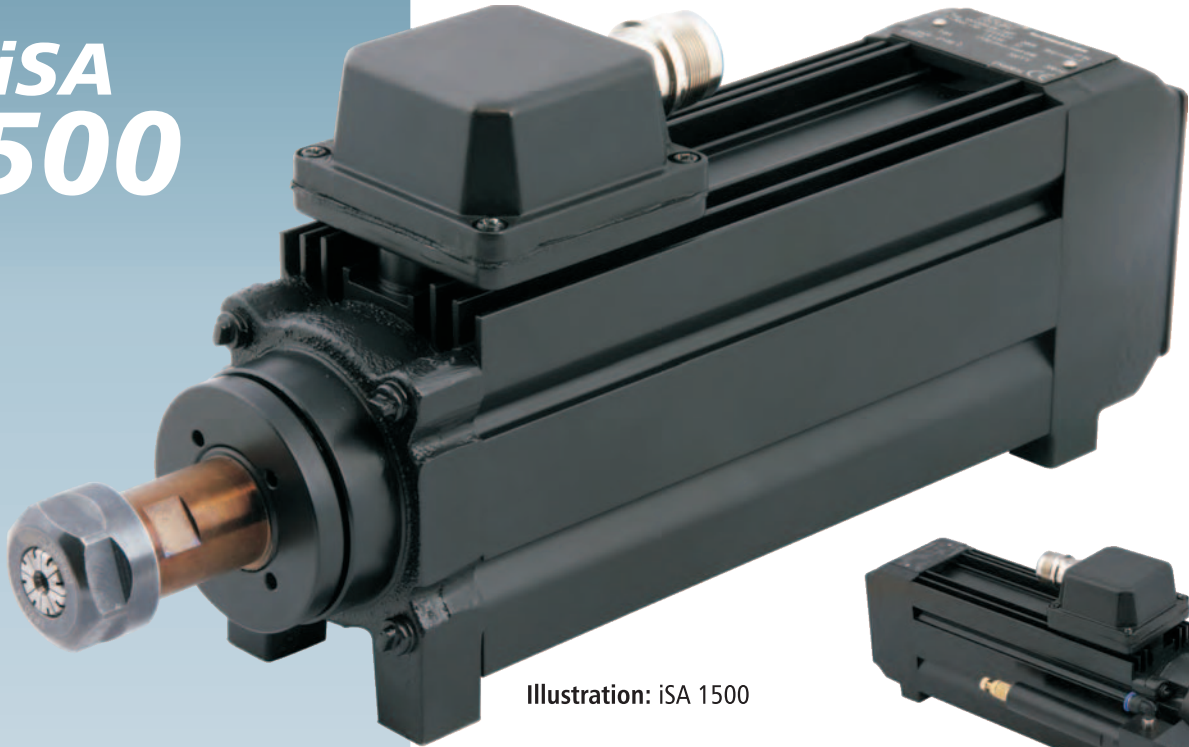

Illustration: iSA 1500



Illustration: iSA 1500
with CoolMin internal

Optional:

- CoolMin tool and material cooling, internally or externally
- Frequency converter
- Collets

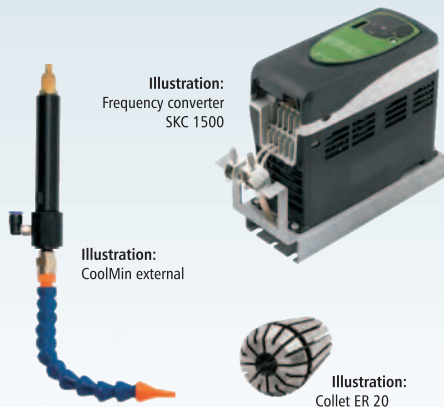

Illustration:
Frequency converter
SKC 1500

Illustration:
CoolMin external

Illustration:
Collet ER 20

- Robust 2-pole three-phase motor
- Protection Class IP54, Insulation Class F
- Motor shaft for ER 20 collets
- Die cast bearing bracket A and B side
- Nominal power output 1.5 kW (S6-40% operation)
- DSpeed range 5,000 rpm — 20,000 rpm
- Torque 0.72 Nm (at 20.000 U/min)
- Nominal voltage 230 V
- Manual tool change
- Clamping range \varnothing 2 mm – \varnothing 13 mm
- Self-ventilation B side
- Speed control by means of frequency converter
- Spindle bearing: A side (milling side) double, B side (fan side) single
- Concentricity: 0.01 mm
- Weight: 6.4 kg

Technical Data

Torque with nominal speed (20,000 rpm)	Nm	0.72
Speed range	rpm	5,000 ... 20,000
Cut-off frequency	Hz	300
Pole number		2
Nominal voltage	V	230
Nominal current	A	7.0
Cos Φ		0.85
Nominal capacity (S6 = 40% operation)	W	1,500
Concentricity	mm	0.01
Weight	kg	6.4

Torque Curve

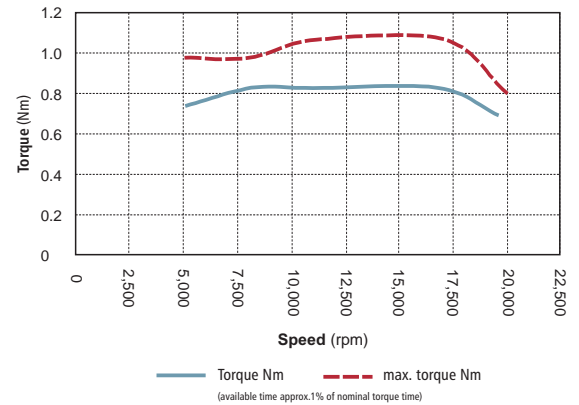

Dimensions

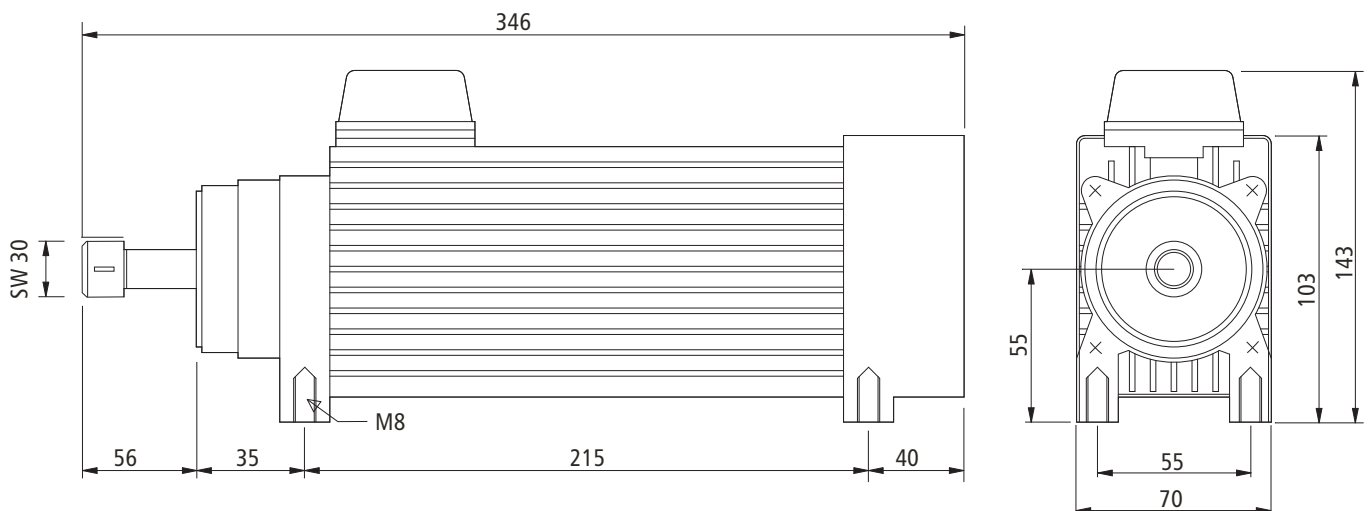

Ordering Information

Item name		Item number
iSA 1500	with collet ER 20 (6 mm), chuck key ER 20, spanner SW 22, Interconnectron connector	477510 3120
iSA 1500 with converter	with collet ER 20 (6 mm), chuck key ER 20, spanner SW 22, Interconnectron connector, connecting cable 8 m	310610 3614
iSA 1500 with CoolMin (internal)	with collet ER 20 (6 mm), chuck key ER 20, spanner SW 22, Interconnectron connector	477510 5120
iSA 1500 with converter + CoolMin (internal)	with collet ER 20 (6 mm), chuck key ER 20, spanner SW 22, Interconnectron connector, connecting cable 8 m	310610 3634
Exhaust device for EuroMod / FlatCom	prepared for Ø 80 mm hose	239012 0001
Collet set ER 20	2.0 / 3.0 / 4.0 / 5.0 / 6.0 / 7.0 / 8.0 / 9.0 / 10.0 / 11.0 / 12.0 / 13.0 mm	239172 0001
Mounting panels for isel Systems (Z axis)	EuroMod / FlatCom (LES 21)	277028 0002
	Linear unit LES 5	277028 0003

Spindle Motors

iSA 900

with
automatic
tool change!

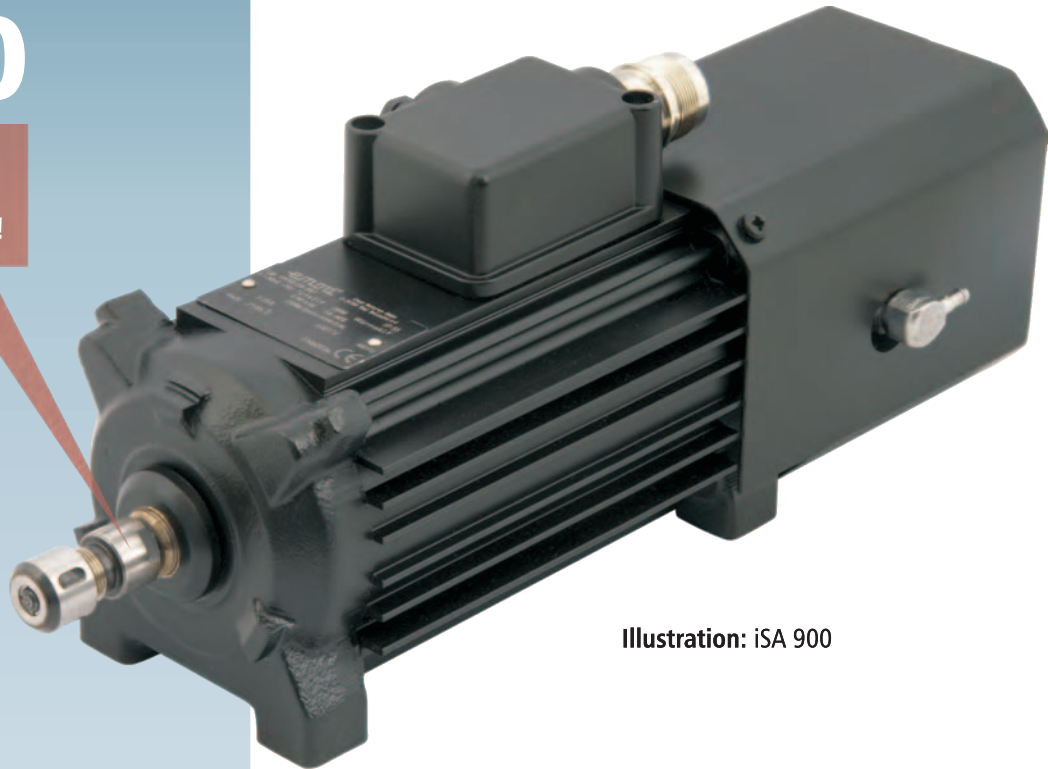

Illustration: iSA 900

Optional:

- CoolMin tool and material cooling externally
- Frequency converter
- Tool changers
- Collets



- Robust 2-pole three-phase motor
- Protection Class IP55, Insulation Class F
- Die cast bearing bracket A and B side
- Nominal power output 0.9 kW (S6-40% operation)
- Speed range 6,000 rpm — 24,000 rpm
- Torque 0.37 Nm (at 24,000 rpm)
- Nominal voltage 230 V
- Automatic tool change
- Clamping range \varnothing 1.0 - 7.0 mm
- Separately driven fan B side
- Speed control by means of frequency converter
- Dual precision bearing
- Tool change SK 11 pneumatic (7.5 bar)
- Concentricity: 0.01 mm
- Weight: 5.8 kg

Technical Data

Torque with nominal speed (22,000 rpm)	Nm	0.37
Speed range	rpm	6,000 ... 24,000
Cut-off frequency	Hz	400
Pole number		2
Nominal voltage	V	230
Nominal current	A	3.25
Cos Φ		0.84
Nominal capacity (S6 = 40% operation)	W	900
Concentricity	mm	0.01
Weight	kg	5.8

Torque Curve

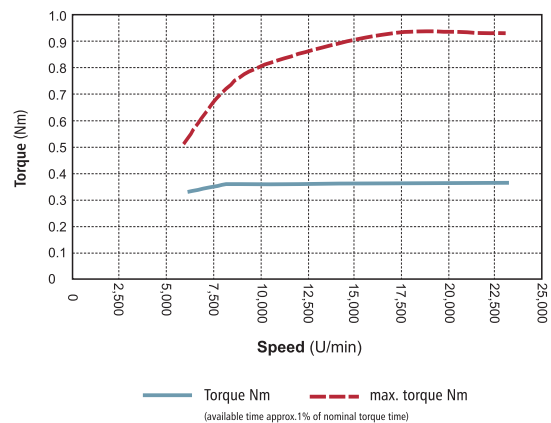

Dimensions

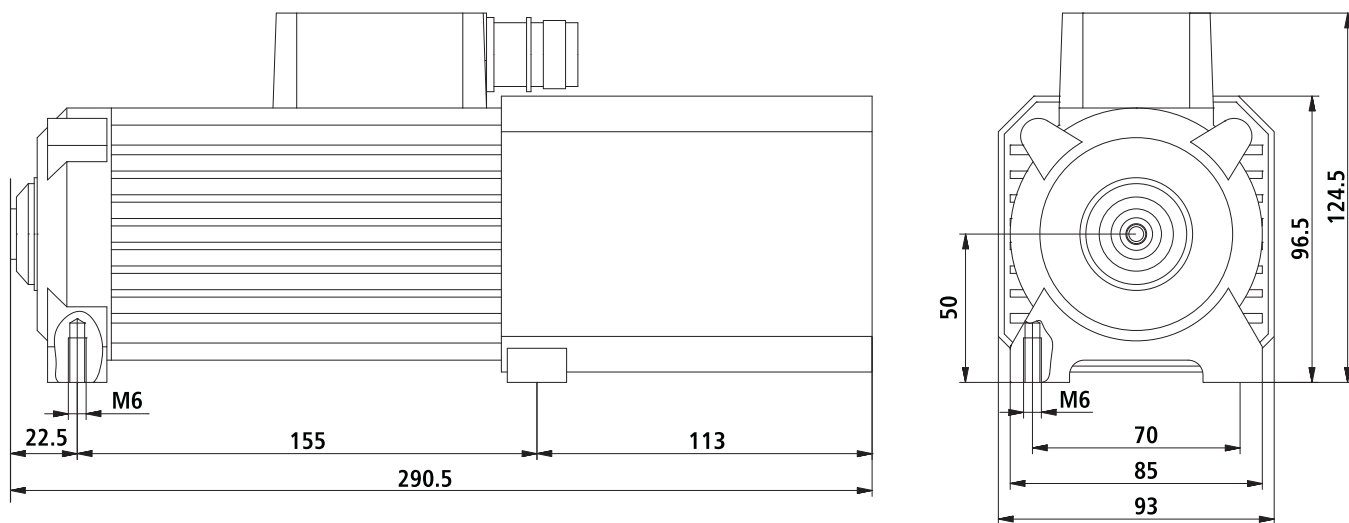

Ordering Information

Item name		Item number
iSA 900	with collet ER 11 (6 mm), clamping nut ERM 11, chuck key ER 11 M, spanner SW 17, Interconnectron connector	477009 3324
iSA 900 with converter	as described above, plus frequency converter SKC 1500, motor connection cable 8 m	310709 3612
Tool change station SK 11	5x with hood	239011 0053
Tool change station SK 11	5x without hood	239011 0054
Tool holder SK 11	for collet ER 11	239111 0001
CoolMin	external	239011 0119
Collet set ER 11	1 – 7 mm	239170 0001
Mounting panels for isel Systems (Z axis)	LES 5	277028 0003

Spindle Motors

iSA 2200

with
automatic
tool change!

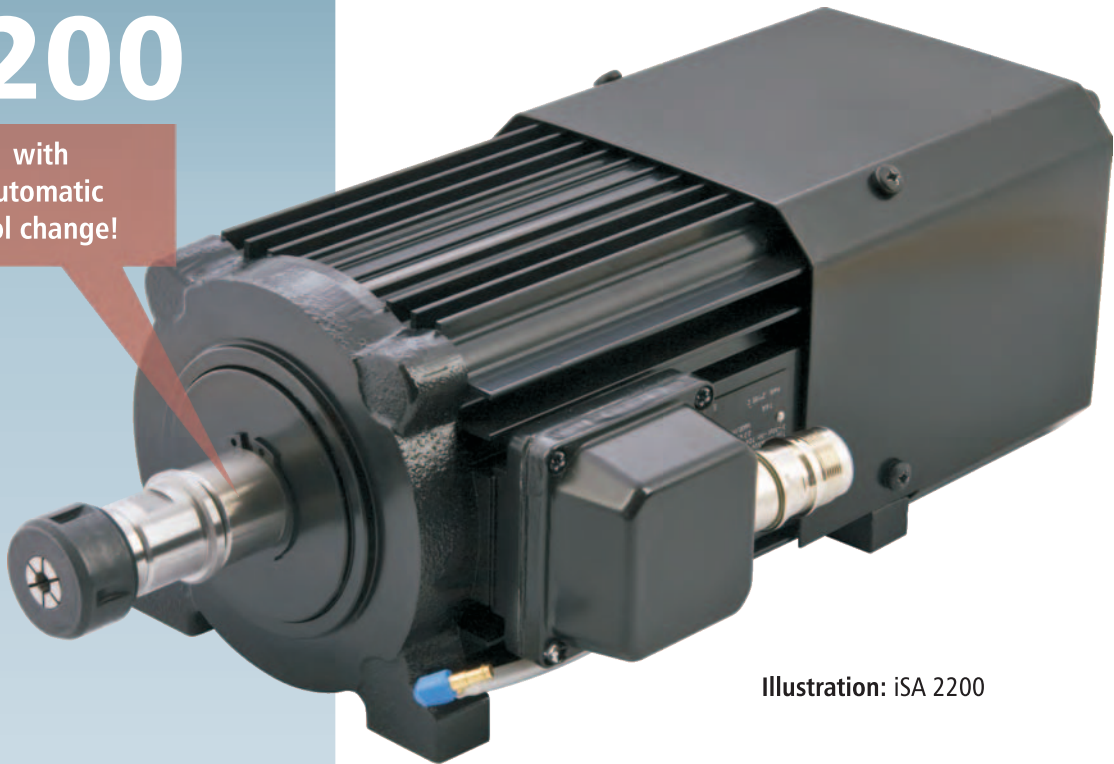

Illustration: iSA 2200

Optional:

- CoolMin tool and material cooling externally
- Frequency converter
- Tool changers
- Collets



Illustration:
CoolMin externally



Illustration:
Frequency converter
SKC 4000



Illustration:
Collet ER 20

- Robust 2-pole three-phase motor
- Protection Class IP55, Insulation Class F
- Die cast bearing bracket A and B side
- Nominal power output 2.2 kW (S6-40% operation)
- Speed range 5,000 rpm — 20,000 rpm
- Torque 1.26 Nm (at 18,000 rpm)
- Nominal voltage 3 x 230 V
- Automatic tool change
- Clamping range \varnothing 2 mm – \varnothing 13 mm
- Separately driven fan B side
- Speed control by means of frequency converter
- Dual precision bearing
- Tool change SK 20 pneumatic (7.5 bar)
- Concentricity: 0.01 mm
- Weight: 14.6 kg

Technical Data

Torque with nominal speed (18,000 rpm)	Nm	1.26
Speed range	rpm	5,000 ... 20,000
Cut-off frequency	Hz	280
Pole number		2
Nominal voltage	V	3x 230
Nominal current	A	7.6
Cos Φ		0.84
Nominal capacity (S6 = 40% operation)	W	2,200
Concentricity	mm	0.01
Weight	kg	14.6

Torque Curve

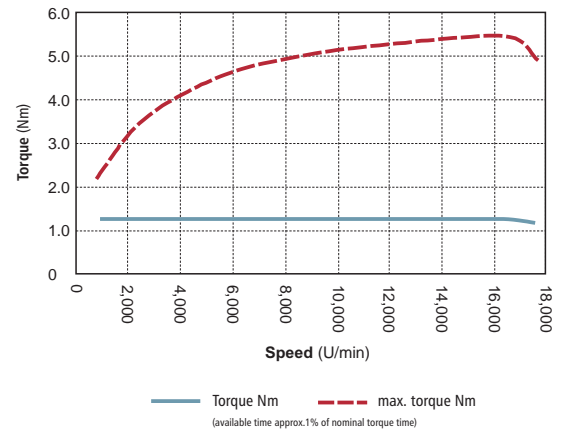

Dimensions

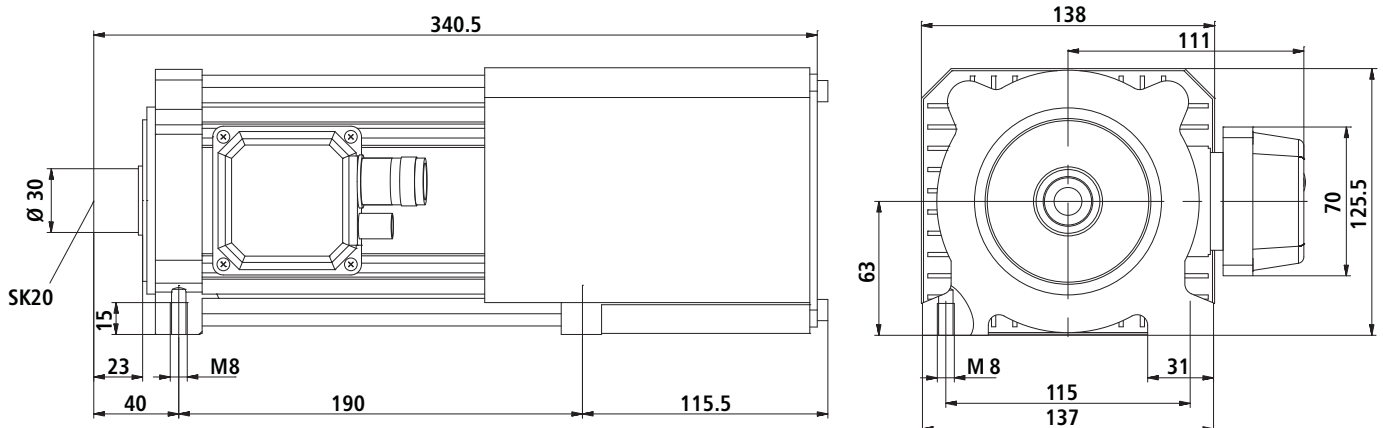

Ordering Information

Item name		Item number
iSA 2200	with collet ER 20 (6 mm), clamping nut ERM 20, chuck key ER 20 M, spanner SW 22, Interconnectron connector	477022 3320
iSA 2200 with converter	as described above, plus frequency converter SKC 4000, motor connecting cable 8 m	310722 3621
Tool change station SK 20	4x with hood	239011 0041
Tool holder SK 20		239172 0020
Exhaust device for EuroMod / FlatCom	for Ø 80 mm hose	239012 0002
CoolMin	external	239011 0119
Collet set ER 20	2.0 / 3.0 / 4.0 / 5.0 / 6.0 / 7.0 / 8.0 / 9.0 / 10.0 / 11.0 / 12.0 / 13.0 mm	239172 0001
Mounting panels for isel Systems (Z axis)	FlatCom / EuroMod	277028 0004
	LES 5	277028 0005

Spindle Motors

iSA 3600

with
automatic
tool change!

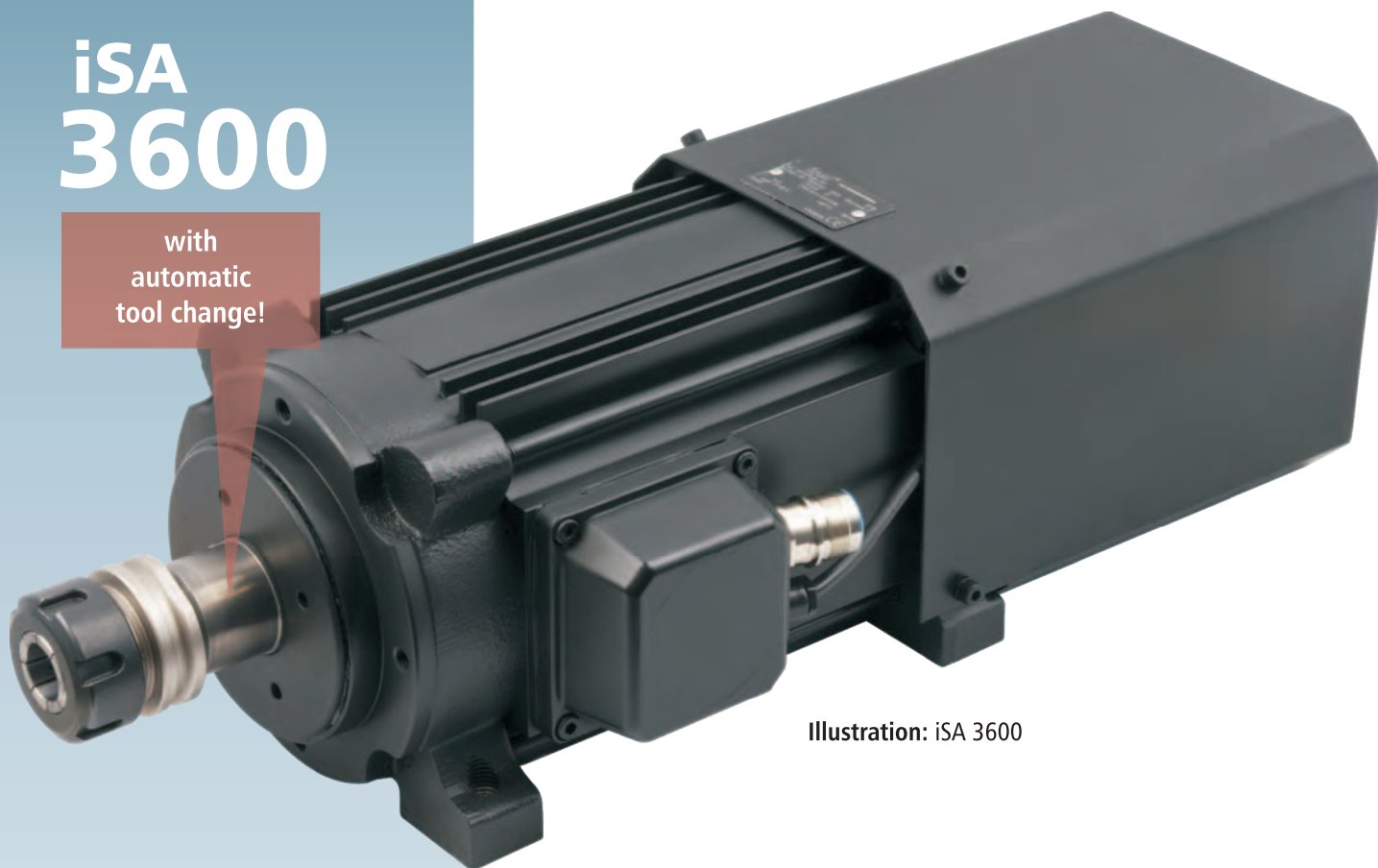

Illustration: iSA 3600

Optional:

- CoolMin tool and material cooling externally
- Frequency converter
- Tool changers
- Collets



Illustration:
CoolMin externally

Illustration:
Frequency converter
SKC 4000

Illustration:
Collet ER 32

- Robust 2-pole three-phase motor (asynchronous motor)
- Rectangular design, Protection Class IP54, Insulation Class F
- Steel bearing bracket A side
- Cast bearing bracket B side
- Nominal capacity 3.6 kW (S6-40% operation)
- Speed range 6,000 rpm – 18,000 rpm
- Torque 4.5 Nm (at 18.000 U/min.)
- Nominal voltage 3 x 400 V
- Automatic tool change SK 30
- Clamping range \varnothing 3 mm – \varnothing 20 mm
- Self-ventilation B side
- Dual precision bearing
- Speed control by means of frequency converter
- For machining aluminium, wood, plastics and non-ferrous metals

Technical Data

Torque with nominal speed (18,000 rpm)	Nm	4.5
Speed range	rpm	6,000 ... 18,000
Cut-off frequency	Hz	300
Pole number		2
Nominal voltage	V	3x 400
Nominal current	A	5.4
Cos Φ		0.87
Nominal capacity (S6 = 40% operation)	W	3,600
Concentricity	mm	0.01
Weight	kg	23.0

Torque Curve

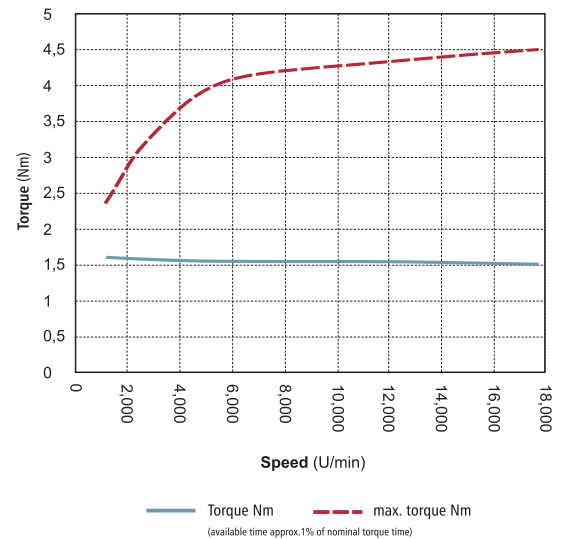

Dimensions

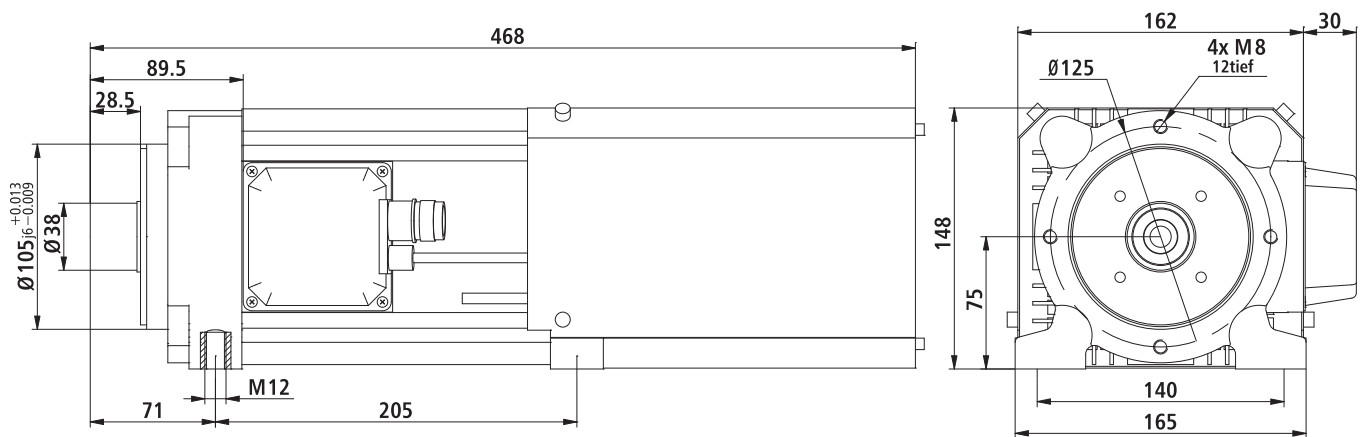

Ordering Information

Item name		Item number
iSA 3600	with collet ER 32 (6 mm), clamping nut ERM 32, chuck key ER 32 M, spanner SW 47, Interconnectron connector	477822 3600
iSA 3600 with converter	as described above, plus frequency converter SKC 4000, motor connecting cable 8 m	310736 3615
Tool change station SK 30	4x with hood	239011 0045
Tool holder SK 30		239130
CoolMin	external	239011 0119
Collet set ER 30	3.0 / 4.0 / 5.0 / 6.0 / 7.0 / 8.0 / 9.0 / 10.0 / 11.0 / 12.0 / 13.0 / 14.0 / 15.0 / 16.0 / 17.0 / 18.0 / 19.0 / 20.0 mm	239130 0000
Mounting panels for isel Systems (Z axis)	LES 5	277028 0009

Spindle Motors

UFM 500 1050



Illustration:
UFM 1050

Illustration:
UFM 500

Optional:

- Collets
- Clamping block
- Clamping nuts
- Carbon brushes



Illustration:
Clamping nut for UFM 1050 and/or UFM 500



Illustration:
Clamping block Ø 43mm



Illustration:
Collet ER 11

- Load-independent thanks to tachometer control electronics
- Soft start for acceleration without jolting at nominal speed
- Jam protection
- Protective insulation
- PTC thermal monitoring
- Nominal power output 345 W / 720 W
- Speed range 11,000 rpm — 25,000 rpm
- Torque 0.14 Nm (at 22,600 and/or 21,000 rpm)
- Nominal voltage 230 V
- Collar
- Clamping range Ø 1 mm – Ø 6.35 / 8 mm
- Speed control
- Stable dual ball bearing
- Weight: 1.9 or 2.1 kg

Technical Data

Torque with nominal speed (18,000 rpm)	Nm	0.14 / 0.32
Speed range	rpm	11,000...25,000
Nominal voltage	V	230 (110)
Efficiency	%	68 / 71
Nominal capacity (S6 = 40% operation)	W	345 / 720
Weight	kg	1.9 / 2.1

Dimensions

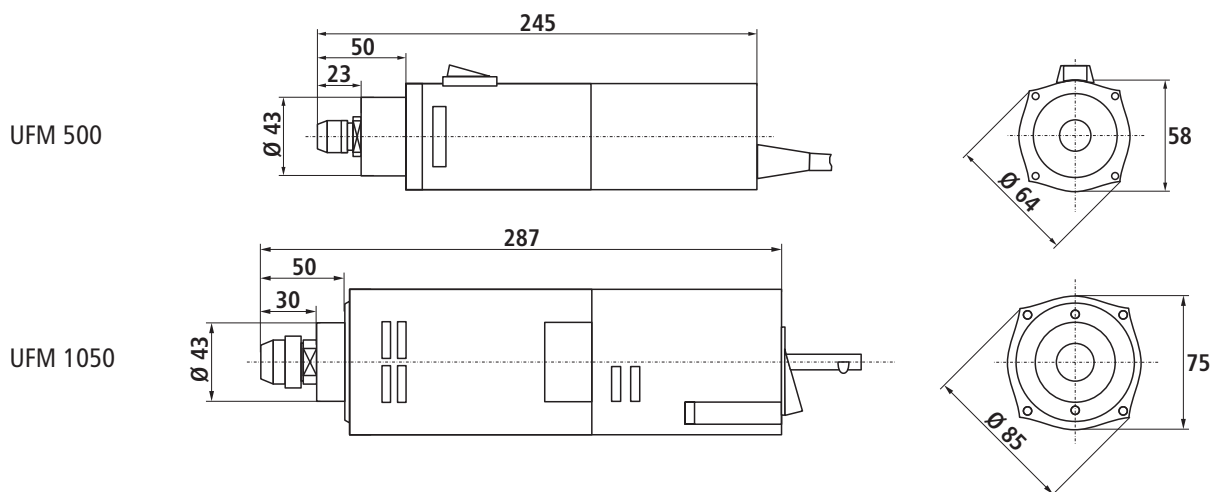

Order Information

Item name		Item number
Spindle motor UFM 500	230 V design, with clamping nut, spanner SW 17, hook spanner	420003 0500
Spindle motor UFM 500-11	115 V design, with clamping nut, spanner SW 17, hook spanner	420003 0501
Spindle motor UFM 1050	230 V design, with clamping nut, spanner SW 17, hook spanner	420003 1050
Spindle motor UFM 1050-11	115 V -design, with clamping nut, spanner SW 17, hook spanner	420003 1051
Collet set for UFM 500	1.0 / 1.5 / 2.0 / 2.5 / 3.0 / 3.175 / 3.5 / 4.0 / 4.5 / 5.0 / 5.08 / 5.5 / 6.0 / 6.3 mm	239110
Collet set for UFM 1050	1.0 / 1.5 / 2.0 / 2.5 / 3.0 / 3.175 / 3.5 / 4.0 / 5.0 / 6.0 / 6.35 / 6.5 / 7.0 / 8.0 mm	239112 0000
Clamping blocks	Fastening grid 100 and 150 mm / 100 mm / 125 mm for collar Ø 43 mm	290902 / 290903 / 290904
Clamping nut	for UFM 500 / UFM 1050	239111 / 239112
Carbon brushes	for UFM 500 / UFM 1050, packaging unit = 2 pieces	420003 9000 / 420003 9001

Tool Cooling

CoolMin

Functional principle

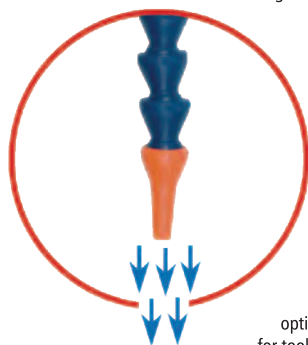
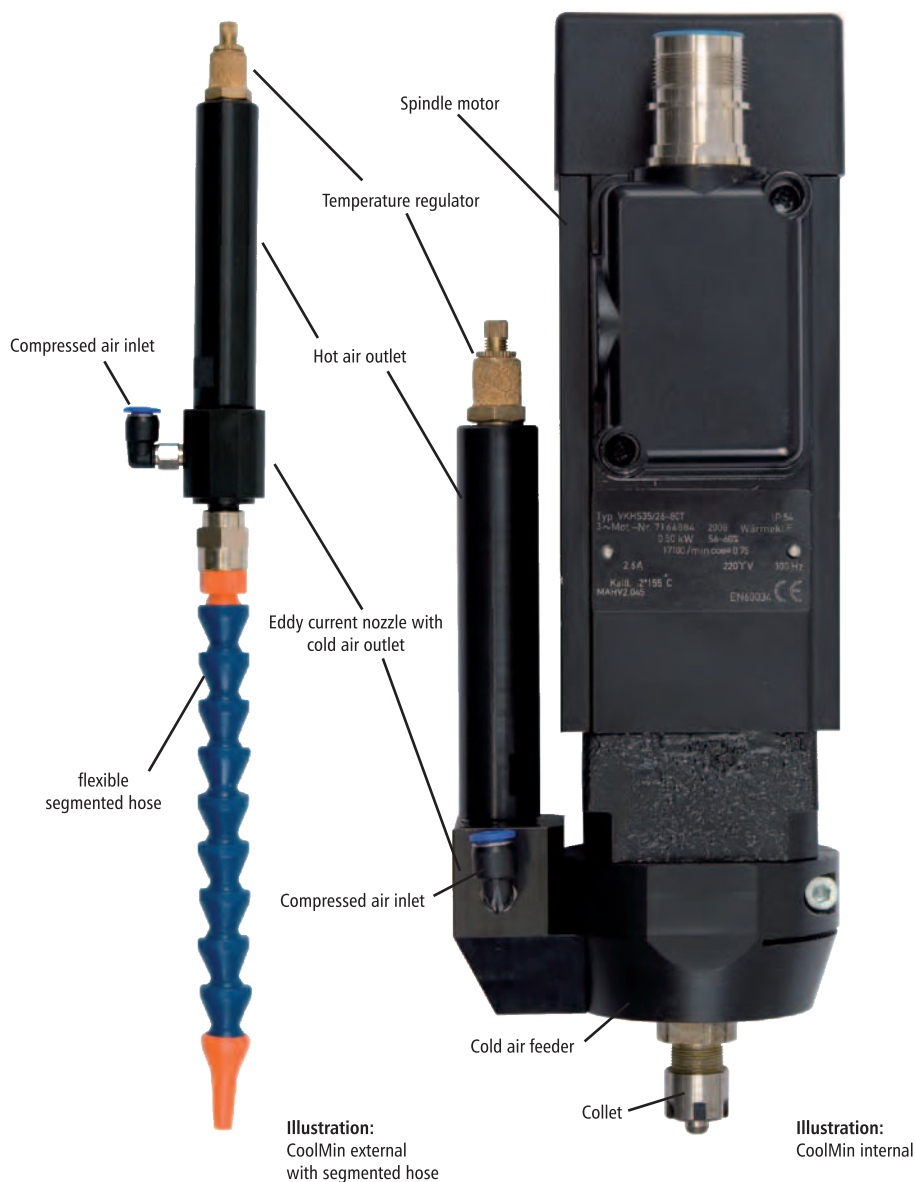
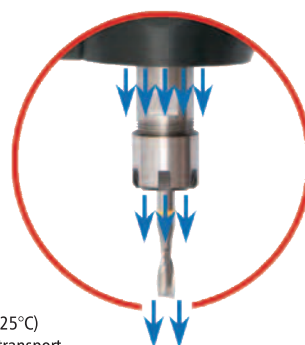

Illustration: optimum cold air flow (to -25°C) for tool cooling and shavings transport



Tool and Material Cooling

Dry material removal is the first choice today for many machining tasks. Previously, material, tool wear and surface quality often entailed cooling with coolants/lubricants. This always meant introducing moisture. Even spray cooling with minimum quantities leads to undesirable side effects such as contamination, chips sticking to the tool or surface and, depending on the material, corrosion on the surface of the material.

With the patented cooling method shown here, the side effects are negligible and there is very good cooling of tool and surface. The shavings are dry and, depending on the material, easy to vacuum or blow off. The surface is undamaged, while direct cooling (also suitable for tools with internal cooling) means very long usage times are attained for the tools.

The cooling method is based on a cold air nozzle that works according to the eddy current principle. It splits the air stream to warm air and cold air. Only compressed air (6 to 10 bar) is required for system operation.

Technical Data

Compressed air inlet	6-10 bar
Cool air outlet	to max. -25°C
Hot air outlet	to max. 70°C
Air consumption	approx. 150 l/min.

Order Information

Item name		Item number
CoolMin external	with hose, including maintenance unit and shut-off valve (manual)	239011 0119
CoolMin external	including maintenance unit and electrically activated valve	239011 0117
CoolMin internal		see individual motors

Tool Changers

SK 11
SK 20
SK 30

Illustration:
4x linear changer
for SK 20

Illustration:
5x linear changer
for SK 11

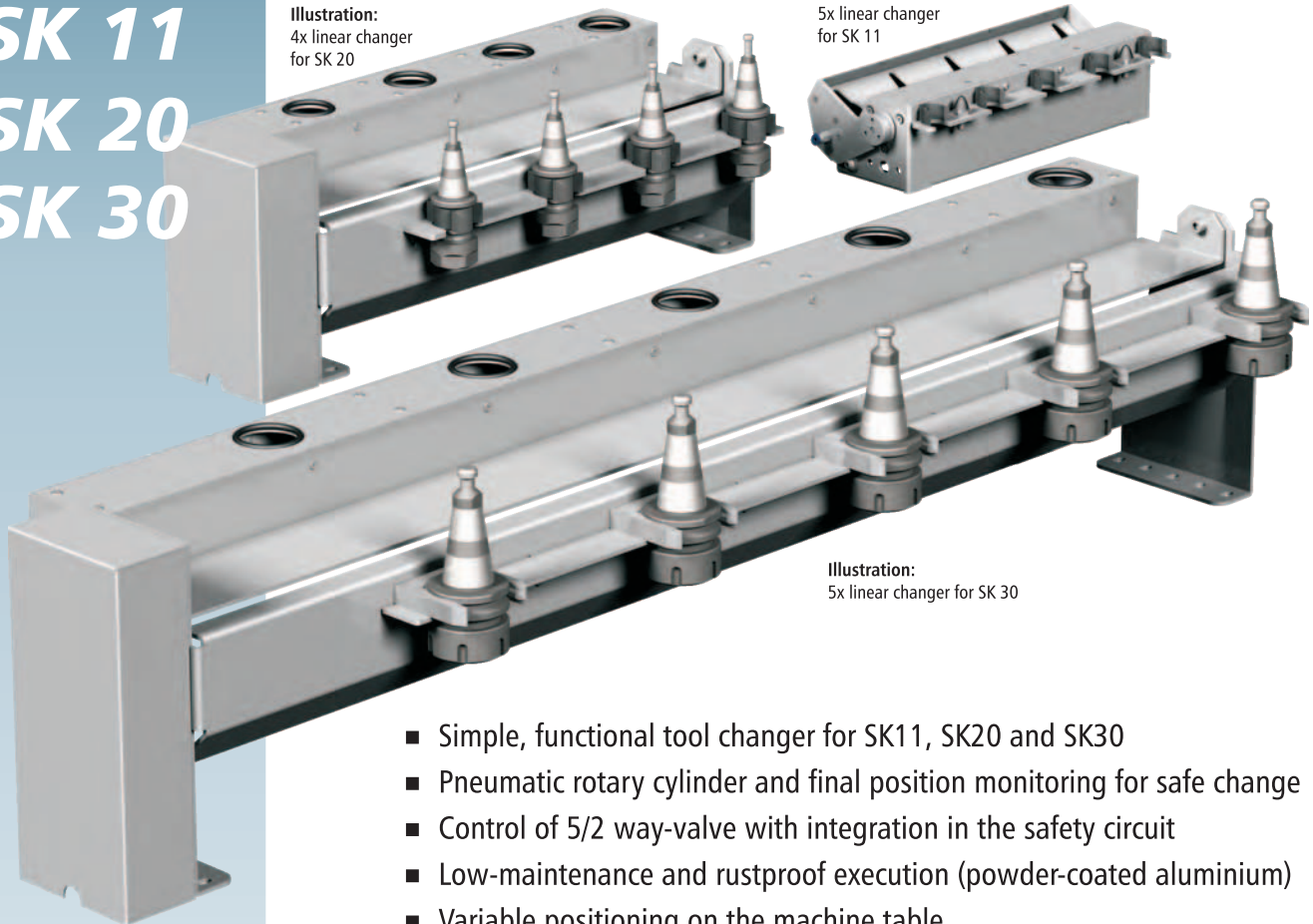

Illustration:
5x linear changer for SK 30

- Simple, functional tool changer for SK11, SK20 and SK30
- Pneumatic rotary cylinder and final position monitoring for safe change
- Control of 5/2 way-valve with integration in the safety circuit
- Low-maintenance and rustproof execution (powder-coated aluminium)
- Variable positioning on the machine table

Order Information









Tool holder SK 11	Tool holder SK 20	Tool holder SK 30
 <p>Pull stud ER 11 Item no.: 639002</p>	 <p>Pull stud SK 20 Item no.: 639032</p>	 <p>Tool holder SK 30 Item no.: 239130</p>
 <p>Holder ER 11 Item no.: 639001 0000</p>	 <p>Holder SK 20-ER 2 Item no.: 639031 0002</p>	
 <p>Collet ER 11 Item no.: 239170 xxxx</p>	 <p>Collet ER 20 Item no.: 239172 xxxx</p>	
 <p>Clamping nut ER 11 M M13x0.75 Item no.: 239170</p>	 <p>Clamping nut ER 20 M25x1.5 Item no.: 239172</p>	

Illustration:
SK 30

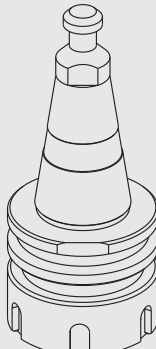
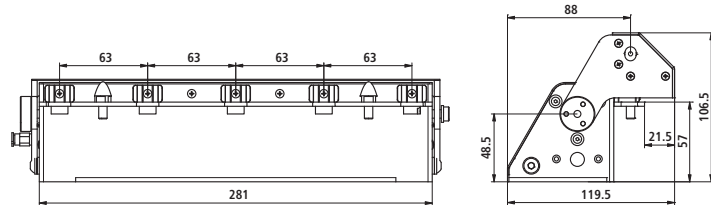

Illustration:
SK 20

Illustration:
SK 11

Dimensions

Tool changer SK 11



Tool changer SK 20

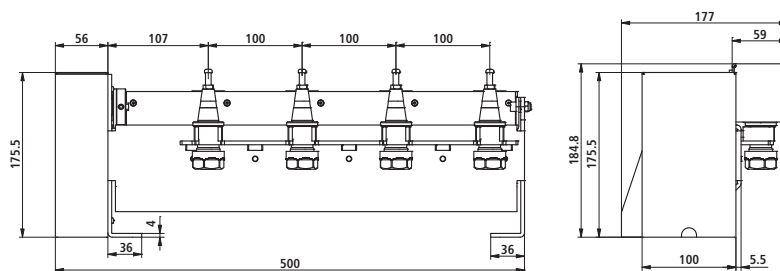

Tool changer SK 30

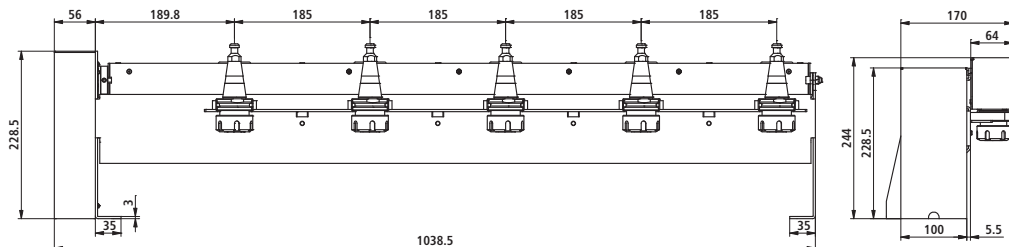

Order Information

Item name		Item number
Tool change station SK 11	5x, without cover / for EuroMod, FlatCom, iSA 900	239011 0054
Tool change station SK 11	8x, without cover / for EuroFMod, FlatCom, iSA 900	239011 0084
Tool change station SK 11	5x, with cover and pneumatics / for EuroMod, FlatCom, iSA 900	239011 0053
Tool change station SK 11	8x, with cover and pneumatics / for EuroMod, FlatCom, iSA 900	239011 0083
Tool change station SK 20	4x, with cover and pneumatics / for EuroMod, FlatCom, inc. portal, iSA 2200	239011 0041
Tool change station SK 20	5x, with cover and pneumatics / for FlatCom XL, iSA 2200	239011 0050
Tool change station SK 20	10x, with cover and pneumatics / for FlatCom XL, iSA 2200	239011 0100
Tool change station SK 30	4x, with cover and pneumatics / for FlatCom XL, iSA 3600	239011 0045
Tool change station SK 30	5x, with cover and pneumatics / for FlatCom XL, iSA 2200	239011 0055
Tool holder SK 11	for collets type ER 11	239111 0001
Tool holder SK 20	for collets type ER 20	239172 0020
Tool holder SK 30	for collets type ER 32	239130

Frequency Converter

SKC 750
SKC 1500
SKC 4000

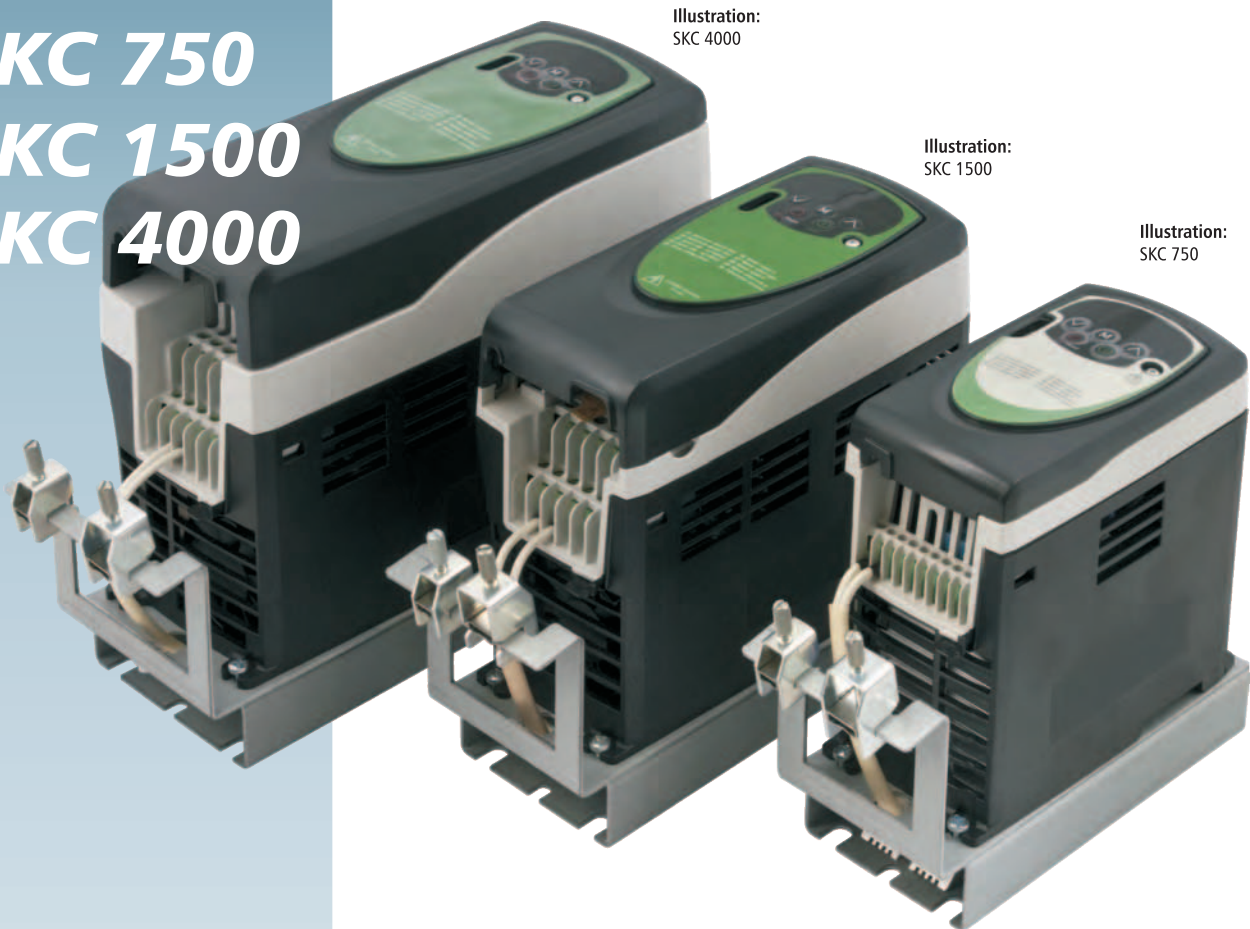

Illustration:
SKC 4000

Illustration:
SKC 1500

Illustration:
SKC 750

- Compact, pulse width modulated equipment in three power classes
- Input voltage single-phase 230 V AC (SKC 750/1500) and/or three-phase 400 V AC (SKC 4000)
- Three-phase, vector-controlled control voltage, frequency 0...1500 Hz
- Fast braking of the spindle through high capacity braking resistor integrated in the substructure
- Disengaged EMV filter
- Programmable input and output, relay output
- Easily operated device for the parameterizing of the spindle
- 95 operating and indicator parameters for simple as well as demanding applications (e. g. energy reduction of the spindle in idle)
- Protection Class: IP 20
- Types of access: SPS; 0...10 V; 0...20 mA; with operating device; CAN bus (plug-in required)
- Certifications: CE; C-Tick; UL

Technical Data

		SKC 750	SKC 1500	SKC 4000
AC mains voltage	V	1x 200-240 V ±10%		3x 380-480 V ±10%
AC mains frequency	Hz	48 - 62		
Input power factor	cos φ	>0.97		
Converter output power	VA	960	1,680	4,320
Output voltage and frequency		3-phase, 0 to nominal value, 0 – 1,500 Hz		
100% nominal output current	A	4.0	7.0	9.0
150% overload current for 60 s	A	6.0	10.5	13.5
Typical input current at full load	A	10.5	17.4	11.9
Max. continuous input current*	A	---	---	13.4
Typ. starting current (<10 ms)	A	17.9	8.9	11.9
Weight	kg	1.0	1.4	2.1

* With 3-phase input only 2% negative phase sequence

Dimensions (mm)

	SKC 750	SKC 1500	SKC 4000
A	140	190	240
B	154	205	258
C	11	10.9	10.4
D	64	65.9	81.1
E	75	85	100
F	145	156	173
G	104	155.5	*
H	143	194	244

* SKC 4000 cannot be mounted on DIN top hat rails

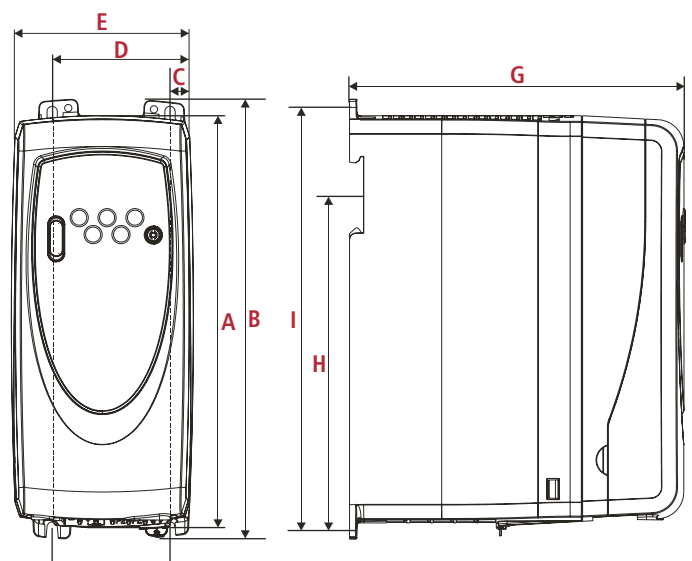

Order Information

Item name		Item number
Frequency converter SKC 750	suitable for / compatible with spindle motors iSA 500, iSA 750 and iSA 900	311707 6000
Frequency converter SKC 1500	suitable for / compatible with spindle motor iSA 1500	311715 6000
Frequency converter SKC 4000	suitable for / compatible with spindle motors iSA 2200 and iSA 3600	311740 6500

Accessories

Dust Extraction

Illustration:
Dust cover closed

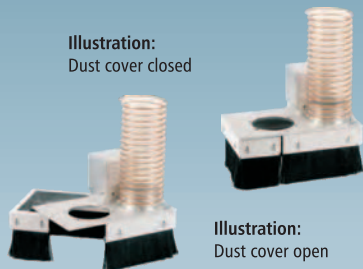

Illustration:
Dust cover open

Order Information

Item name		Item number
for iSA 500 // iSA 750	manual opening, for 38 mm hose	239012 0000
for iSA 1500	manual opening, for 80 mm hose	239012 0001
for iSA 2200	automatic opening, for 80 mm hose	239012 0002

Length Measuring Sensor



Order Information

Item name		Item number
Length measuring sensor	to measure tool lengths	239099 0001

Connector Cables

- 8-wire (3 x 0.75 mm² + 1 x PE + 2x (2x 0.34 mm²))
- Suitable for drag-chain use
- Outer shielding plus separately shielded in pairs
- Ready for use

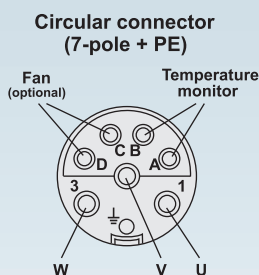

Section	Wire	Wire Cross	Frequency converter
Motor connection	SW 1	0.75 mm ²	U
	SW 2	0.75 mm ²	V
	SW 3	0.75 mm ²	W
	green / yellow	0.75 mm ²	PE
Separately driven fan	green	0.34 mm ²	L1
	yellow	0.34 mm ²	L2 / N
Temperature monitoring	brown	0.34 mm ²	T1
	white	0.34 mm ²	B7

Order Information

Cable Type	Length	Item Number
Motor side: M23 plug connection // converter side: ferrule	3 m	392306 0300
Motor side: M23 plug connection // converter side: ferrule	5 m	392306 0500
Motor side: M23 plug connection // converter side: ferrule	8 m	392306 0800
Motor side: direct connection // converter side: ferrule	3 m	392301 0300
Motor side: direct connection // converter side: ferrule	5 m	392301 0500
Motor side: direct connection // converter side: ferrule	8 m	392301 0800



Collets

Type ER 11 for spindle motor iSA 500/900

Ø (mm)	Item number
1.0	239170 1000
1.5	239170 1500
2.0	239170 2000
2.5	239170 2500
3.0	239170 3000
3.5	239170 3500
4.0	239170 4000
4.5	239170 4500
5.0	239170 5000
5.5	239170 5500
6.0	239170 6000
6.5	239170 6500
7.0	239170 7000

Type ER 16 for spindle motor iSA 750

Ø (mm)	Item number
1.0	239171 1000
2.0	239171 2000
3.0	239171 3000
4.0	239171 4000
5.0	239171 5000
6.0	239171 6000
7.0	239171 7000
8.0	239171 8000
9.0	239171 9000
10.0	239171 0100

Type ER 20 for spindle motor iSA 1500/2200

Ø (mm)	Item number
2.0	239172 2000
3.0	239172 3000
4.0	239172 4000
5.0	239172 5000
6.0	239172 6000
7.0	239172 7000
8.0	239172 8000
9.0	239172 9000
10.0	239172 0100
11.0	239172 0110
12.0	239172 0120
13.0	239172 0130

Type ER 32 for spindle motor iSA 3600

Ø (mm)	Item number
3.0	239130 3000
4.0	239130 4000
5.0	239130 5000
6.0	239130 6000
7.0	239130 7000
8.0	239130 8000
9.0	239130 9000
10.0	239130 0100
11.0	239130 0110
12.0	239130 0120
13.0	239130 0130
14.0	239130 0140
15.0	239130 0150
16.0	239130 0160
17.0	239130 0170
18.0	239130 0180
19.0	239130 0190
20.0	239130 0200

Collet sets*

Type	for spindle motor	Ø (mm)	Item number
ER 11	iSA 500 // iSA 900	1.0 -7.0	239170 0001
ER 16	iSA 750	1.0 -10.0	239171 0001
ER 20	iSA 1500 // iSA 2200	2.0 -13.0	239172 0001
ER 32	iSA 3600	3.0 -20.0	239130 0000

* These collets are also capable of clamping shafts precisely with a diameter reduced by 0.5 mm or 1 mm !



Illustration:
SK 11 collet



Illustration:
SK 16 collet



Illustration:
SK 20 collet

Tool holders see page 22



Illustration:
Collet sets ER 11 / 16 / 20 / 32

Electronics

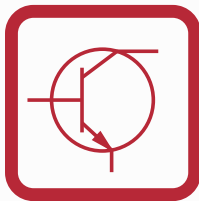

Motors
Controllers
Sensors

Mechanics



Linear Units
Turning Units
Base Units

Software



Applications
CAD / CAM
Drivers

Systems

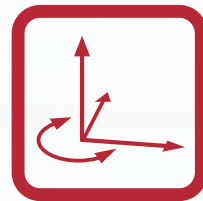

Automation
Handling
Robotics

isel Germany AG

Untere Roede 2 • D-36466 Dermbach
Phone +49(0)6659 / 981-0 • Fax +49(0)6659 / 981-776
E-Mail: automation@isel.com • www.isel-germany.com