

Linear Actuator

Literature



Gold National Award of Excellence 2005

Ball screw

- For Heavy-Load Drive



The National Award of Excellence 2004

Intelligent Linear Guideway

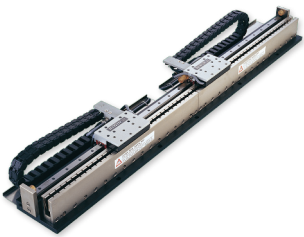

Gold National Award of Excellence 2004

Linear Synchronous Motor

- Coreless Type (LMC)
- Iron-core Type (LMS)



The National Award of Excellence 2002

Linear Actuator

- LAN for Hospital
- LAM for Industrial
- LAS Compact Size
- LAK Controller

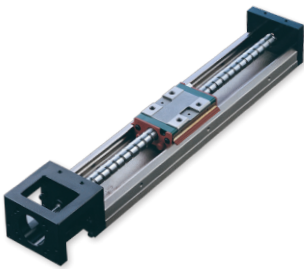

Gold National Award of Excellence 2003

Robot Series

- For Semiconductor & Electronic (KK Series)
- For Automation (KS, KA Series)



Silver National Award of Excellence 2006

TMS Direct-Driven Positioning System

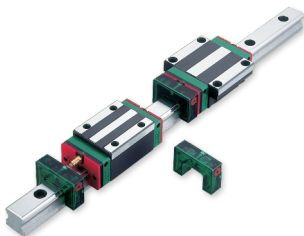

Silver National Award of Excellence 2002

Linear Guideway

- HG/EG/RG/MG Type
- Self-Lubricating (E2)
 - Low Noise (Q1)
 - Air Jet (A1)

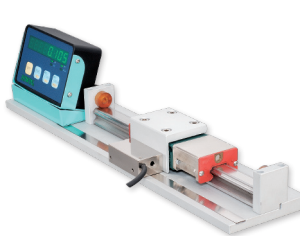

Positioning Measurement System



Silver National Award of Excellence 1993, 2001, 2006

Ball screws

- Ground/Rolled
- High Speed (High Dm-N Value/Super S Series)
 - Heavy Load (Cool type II)
 - Self-Lubricating (E2)
 - Rotating Nut (R1)

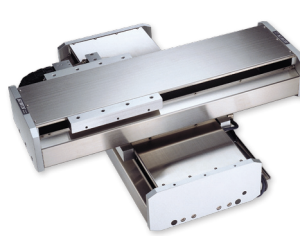

Linear Motor X-Y Stage



Motor Driver



Linear Motor Gantry

HIWIN[®]

Linear Actuator

1.	Sizing of HIWIN Linear Actuator	1
2.	Installation of HIWIN Linear Actuator	1
3.	Safety Operation of Linear Actuator	2
4.	Features and Applications of Linear Actuator	3
5.	HIWIN LAM Series	
	• LAM Model	4
	• LAM Specifications	5
	• LAM3 Model	6
	• LAM3 Specifications	7
6.	HIWIN LAS Series	
	• LAS Model	8
	• LAS Specifications	9
	• LAS3 Model	10
	• LAS3 Specifications	11
	• LAS4 Model	12
	• LAS4 Specifications	13
7.	HIWIN LAN Series	
	• LAN1 Model	14
	• LAN1 Specifications	15
	• LAN2 Model	16
	• LAN2 Specifications	17
	• LAN3 Model	18
	• LAN3 Specifications	19
	• LAN4 Model	20
	• LAN4 Specifications	21
8.	HIWIN 1-Axis Controller	
	• LAK2LR Model	22
9.	HIWIN 2-Axis Controller	
	• LAK2 Model	24
	• LAK2B Model	26
	• LAK2D Model	28
	• LAK2J Model	30
10.	HIWIN 3-Axis Controller	
	• LAK4 Model	32
	• LAK4N Model	34
11.	HIWIN 6-Axis Controller	
	• LAK6B Model	36
	• Over Current Setting Table	39
12.	HIWIN Over Current Protection Box	40
13.	HIWIN Keypad Series (LAP1 / LAP2 / LAP3 / LAP4 / LAP4M / LAP5 Model)	44
14.	Linear Actuator Options	48
15.	HIWIN Customer's Requirements (LA)	49

** The specifications in this catalog are subject to change without notification.

1.

Sizing of *HIWIN* Linear Actuator

Step 1: Determine the load and speed

Consider the operating environment, compare the specifications of various types of Hiwin Linear Actuators and select the most appropriate model.

Step 2: Stroke and retracted length sizing

Consider the dimensions of the operating area and select the appropriate actuator.

Step 3: Duty cycle

Duty cycles should not exceed 10%. If the duty cycle exceeds 10%, the life of the actuator can be reduced. Users should make sure that no torsion or impact forces are acting upon the actuator.

Step 4: Controller Sizing

The selection of controller should be made according to the power requirements of the actuator. Other considerations are number of axes, type of limit switches and the version of keypad.

2.

Installation of *HIWIN* Linear Actuator

1. Please ensure that the extension tube is at the "lowest position". The term "lowest position" refers to the position where there is no further movement towards the DC motor while the actuator is powered on.
2. The front and end joints of the linear actuator should be mounted onto two fixed positions on the main chassis. Locations of these fixed positions should be chosen according to the stroke length of the linear actuator.
3. After the fixed positions have been selected, install the fixtures onto these selected positions of the main chassis. These fixtures are used to fix the front and end joints of the linear actuator.
4. Assemble the front and end joints of the linear actuator onto the two fixtures using fixture bolts. Please ensure that the fixture bolts rotate freely when this step is completed. Also, please ensure that the fixture bolts do not become "loose" and fall off during operation.
5. The chassis of the linear actuator should be mounted in the horizontal direction if it is going to be operated in this direction and likewise for vertical operation. Damages could occur to the actuator if these instructions are not followed.
6. Users of Hiwin actuators please make sure that:
 - The travel distance of the actuator matches the design requirements.
 - The upper and lower limit switches are functioning.
 - The motor stops when the extension tube reaches the upper and lower limit switches.

* If the actuator does not operate as described above, please repeat steps 2 thru 4 to make sure that the installation is correct.

** All *HIWIN* linear actuators and control boxes have to be grounded.

3.

Safety Operating Regulation of *HIWIN* Linear Actuators

1. A no-load operation may damage the actuator, especially if the actuator has external limit switches installed.
2. Please make sure actuators are not installed where the motor or any mechanical parts can be damaged due to dangerous environments.
3. Make sure the DC voltage supplied to the actuator matches the specifications on the actuator. The power supply should supply enough power under maximum load.
4. Under extreme load situations the motor will try to draw more than the rated current. It is the operator's duty to ensure that the power supply does not provide more current than specified on the actuator. Excessive current will cause wiring damage and possible failure to the actuator. Unless otherwise specified, our actuators have a duty cycle rating of 10%. The duty cycle is defined as two minutes continuous operation, followed by 18 minutes of non-operation. If the duty cycle exceeds 10%, please consider over-current protection measures by installing protection devices such as fuses or an over-current detection between power supply and actuator input end. Detection signals are to be used for operation interruption or shut down of the actuators.
5. Thermal protection is included on some linear actuator models by shutting down the motor when over-heated.
6. If the actuator was purchased without limit switches, please install appropriate limit switches that comply with the power supply and over-current protection devices that are used.
7. Actuator's motors are DC driven. When the motor is not in operation, please short the ends of the power input to provide additional locking power. Make sure the controller power is shut off prior to shorting the motor inputs. The movement of the extension tube can be reversed by changing the polarity of voltage supplied.
8. Make sure the actuator operates within its stroke length if it is not supplied with limit switches or over load protection devices.
9. The actuator should operate within the rated load specifications.
10. Please make sure the actuator is operating within the IP rating for dust and water.
11. For applications requiring high accuracy and tight speed requirements please inquire about Hiwin's KK-series linear stages.
12. Electrical self locking should be implemented if the Hiwin controller is not being used, to increase the actuator's locking force.

4.

Features & Applications

4-1 Features of Linear Actuator

- | | |
|---------------------------------------|----------------------|
| 1. Light weight and compact structure | 4. Low noise |
| 2. User friendly | 5. High rigidity |
| 3. Simple installation | 6. Competitive price |

4-2 Applications

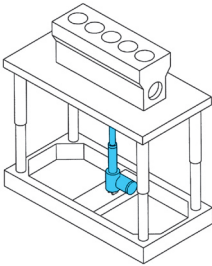
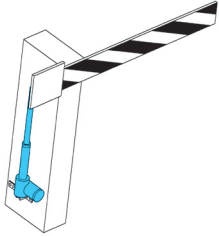
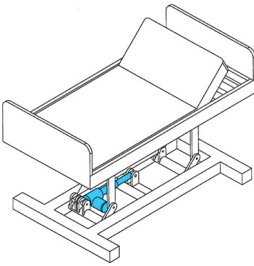
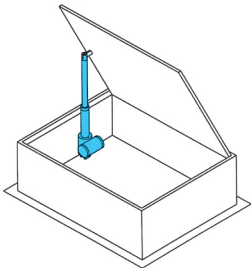
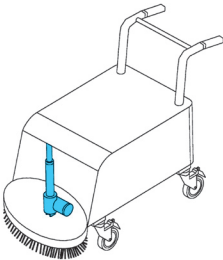
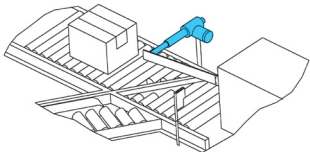
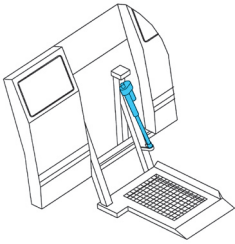
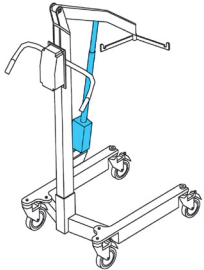
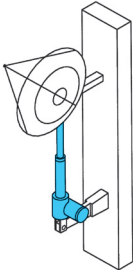
		
		<ul style="list-style-type: none"> ● Automation equipment ● Automatic windows and doors ● Automatic cupboard ● Automatic satellite antenna ● Automatic wheel chair ● Automatic hospital bed ● Entertainment facilities ● Household appliances ● Automatic drawing table ● Home care facilities ● Patient lifter ● Massage chair ● Traffic facilities ● Office automation ● Automatic PC desk ● Hospitals and rehabilitation centers ● Nursing homes
		
		

5.

HIWIN LAM Series (1)

LAM

CE



Screw type	Ball screw / ACME
Weight*	2.31 kg
Protection	IP 54
Compatible controller	LAK2/LAK2LR
Working temp	+5°C ~40°C

* Stroke length 100 mm

* Option: (1) IP65

(2) Gear box material : Steel (Standard: AL)

(3) Gear box housing turned 90°

(4) 36VDC motor

- RL=S+153 (LAM-1/-2)
- RL=S+162 (LAM-1A)
- RL:Retracted length
- S:Stroke length

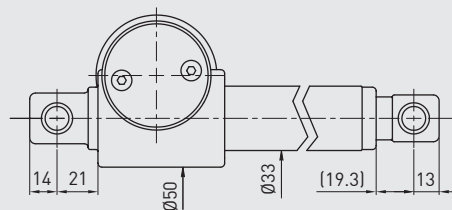
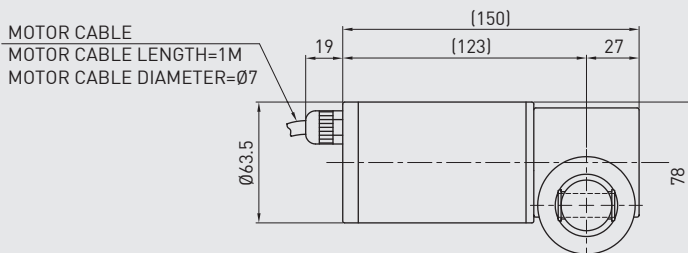
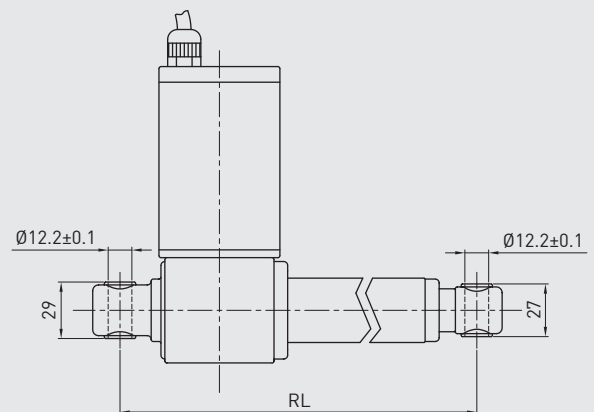

• LAM Specifications

Model	Screw type	Thrust max. (N)	Pulling max. (N)	Holding max. (N)	Speed (mm/s)		Standard stroke (mm) : S							Duty cycle %	Max.current (A)	
					Load=Max.	Load=0	100	150	200	250	300	350	400		12VDC	24VDC
LAM-1	Ball screw	4000	3000	4000	8	11	100	150	200	250	300	350	400	10	12	6
LAM-2	Ball screw	2000	2000	1200	16	21	100	150	200	250	300	350	400	10	12	6
LAM-1A	ACME	3000	3000	3000	8	11	100	150	200	250	300	350	400	10	12	6

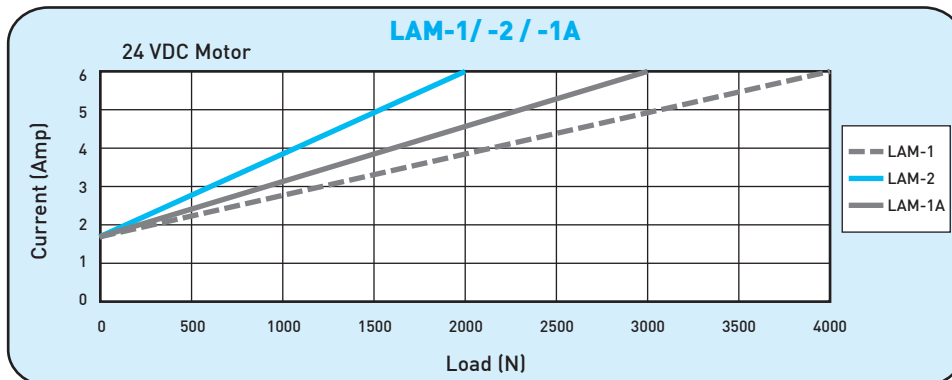
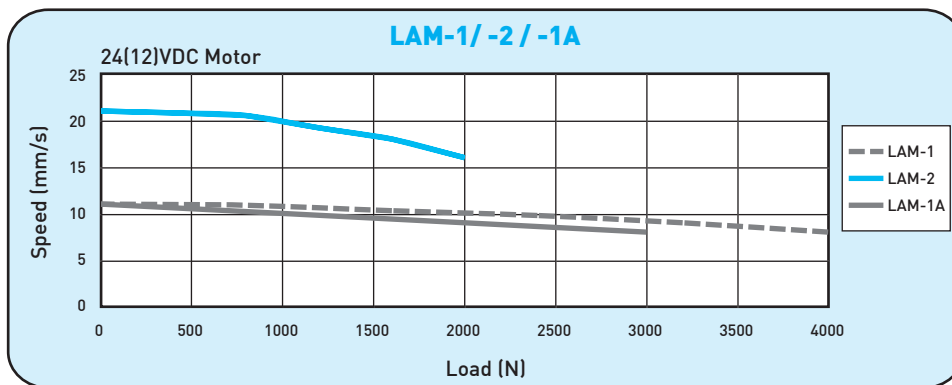

Note: The test results are obtained by using 24VDC power supply.

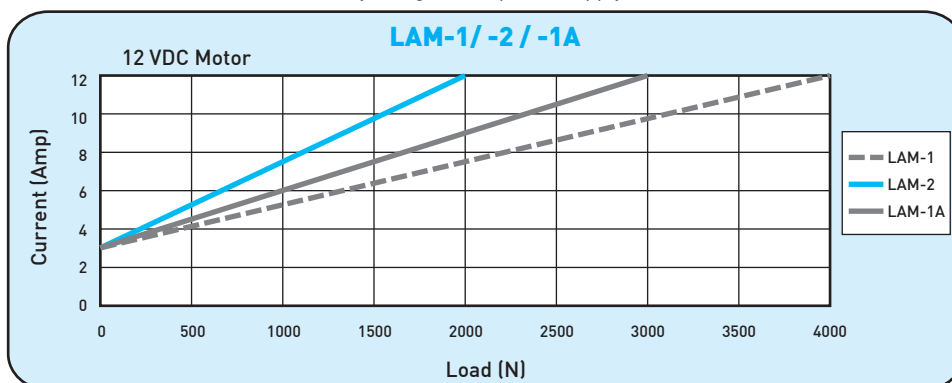

Note: The test results are obtained by using 12VDC power supply.

• Ordering Information

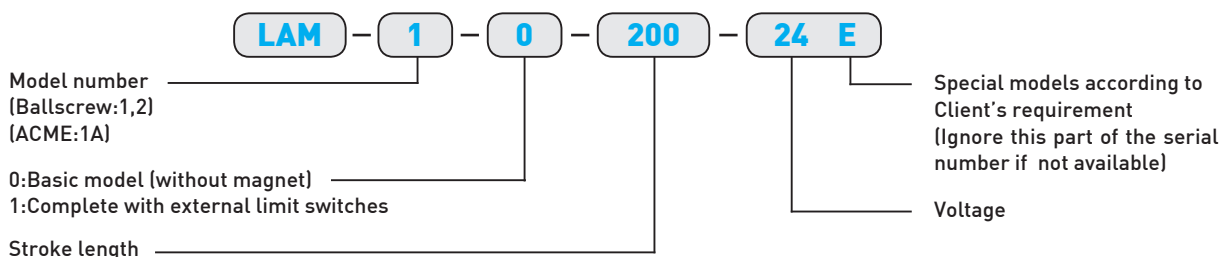

5. *HIWIN* LAM Series (2)

LAM3



Screw type	ACME
Weight*	2.95 kg
Protection	IP 54
Compatible controller	LAK2D/LAK2B LAK4/LAK6B
Working temp	+5°C ~-40°C

- * Stroke length 200 mm
- * Option: (1) IP 66
(2) Safety Nut (RL=S+183)
(3) Back fixture turned 90°

• RL=S+171
RL: Retracted length
S: Stroke length

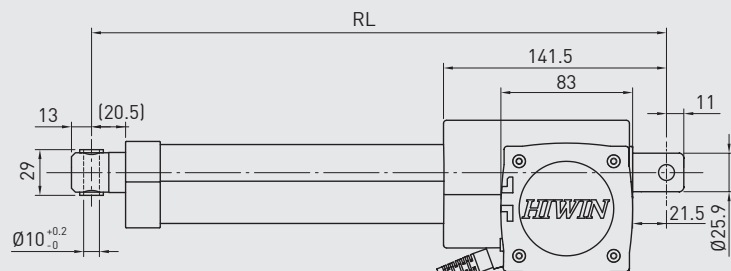
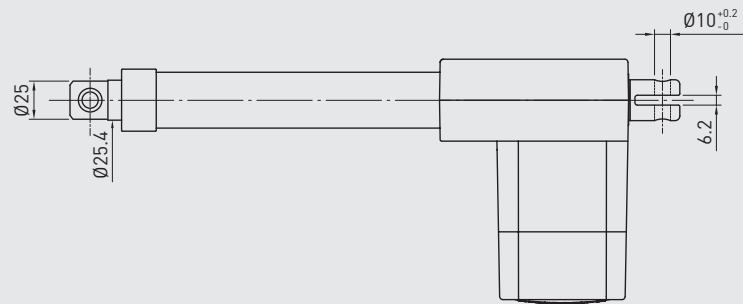
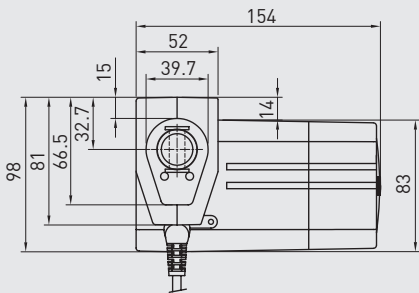

MOTOR CABLE
LENGTH=200mm
DIAMETER=Ø5.5

• LAM3 Specifications

Model	Thrust max. (N)	Pulling max. (N)	Holding max. (N)	Speed (mm/s)		Standard stroke (mm) : S						Duty cycle %	Max.current (A)		
				Load=Max.	Load=0	100	150	200	250	300	350		400	24VDC	12vdc
LAM3-1	6000	5000	5000	4	5.5	100	150	200	250	300	350	400	10	6	12
LAM3-2	4000	4000	4000	5.5	7.5	100	150	200	250	300	350	400	10	5	10
LAM3-3	3000	3000	3000	7	9	100	150	200	250	300	350	400	10	4	8
LAM3-4	2000	2000	1500	11.5	14.5	100	150	200	250	300	350	400	10	4	8

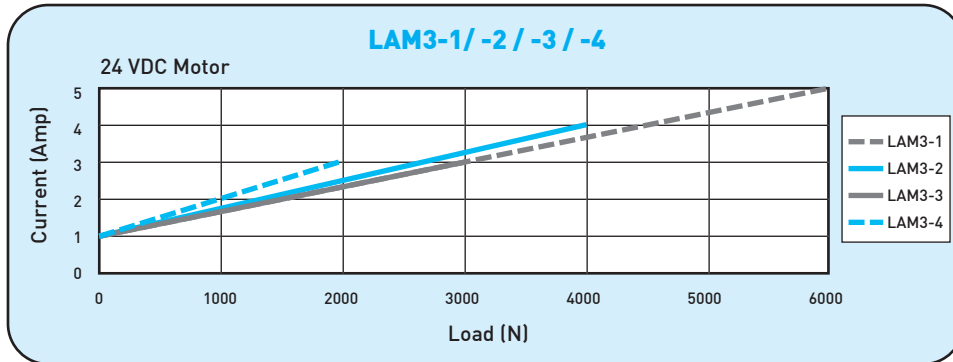
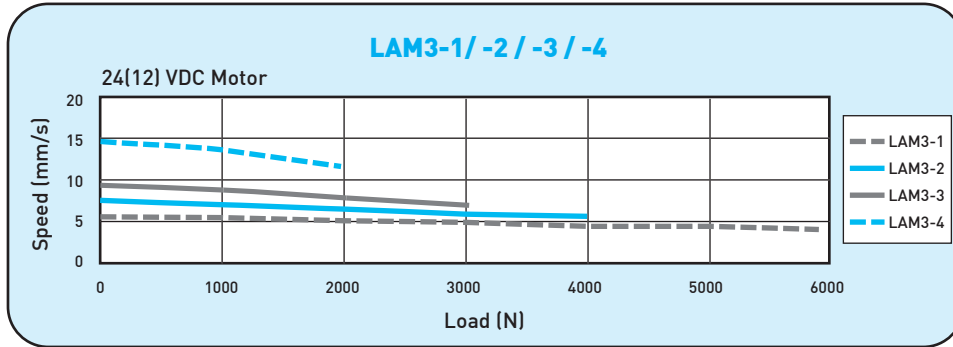

Note: The test results are obtained by using 24VDC power supply.

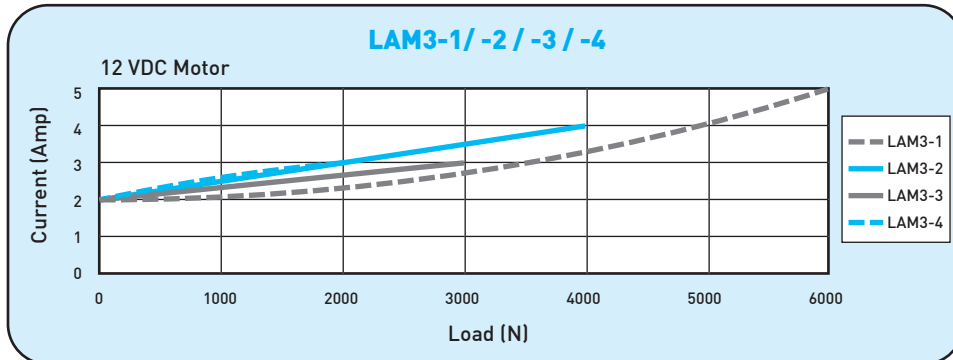

Note: The test results are obtained by using 12VDC power supply.

• Ordering Information

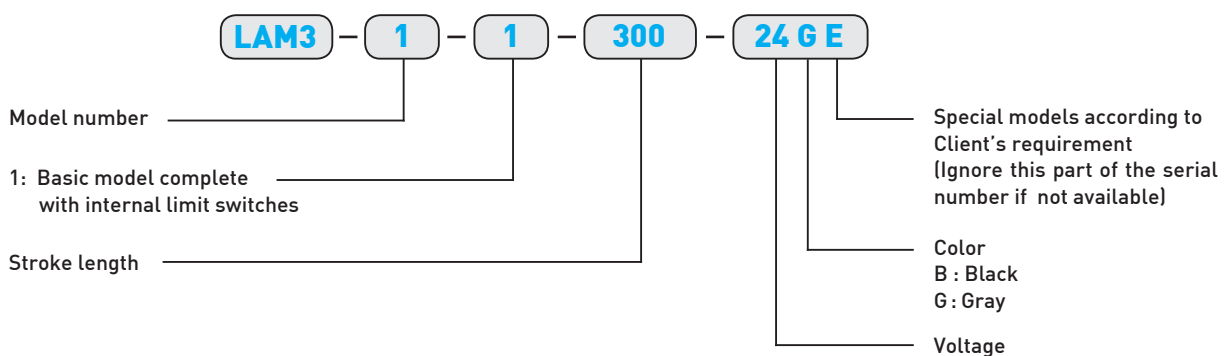

6. **HIWIN LAS Series (1)**

LAS



Screw type	ACME
Weight*	1.04 kg
Protection	IP 54
Compatible controller	LAK2
Working temp	+5°C ~40°C

* Stroke length 200 mm

* Option: (1) IP65

(2) Gear box housing turned 90°

(3) Rod end with flat connector (RL=S+110)

(4) 36VDC motor

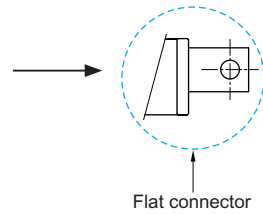

- RL=S+119
RL: Retracted length
S: Stroke length

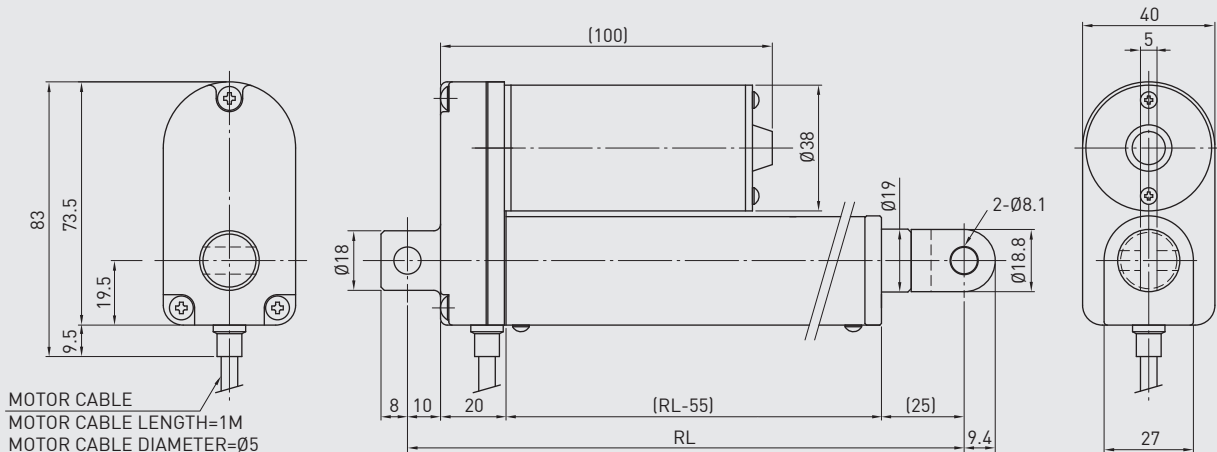

• LAS Specifications

Model	Thrust max. (N)	Pulling max. (N)	Holding max. (N)	Speed (mm/s)		Standard stroke (mm) : S					Duty cycle %	Max.current (A)	
				Load=Max.	Load=0	50	100	150	200	250		12VDC	24VDC
LAS-1	1200	1200	800	8	12	50	100	150	200	250	10	6	2.5
LAS-2	600	600	300	16	25	50	100	150	200	250	10	6	3

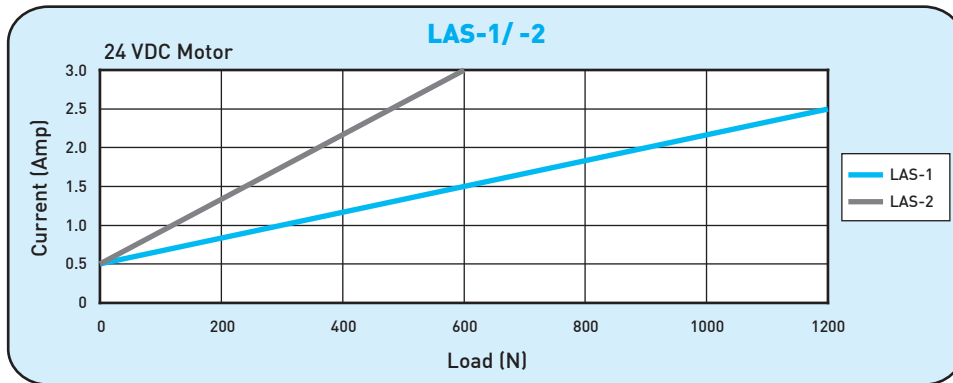
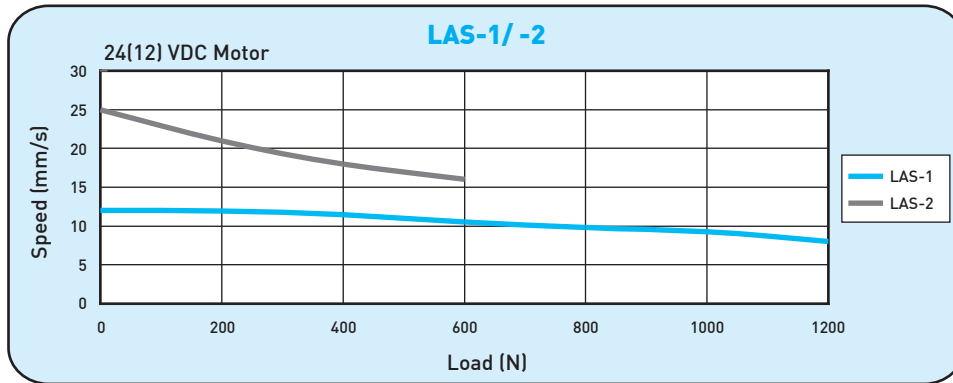

Note: The test results are obtained by using 24VDC power supply.

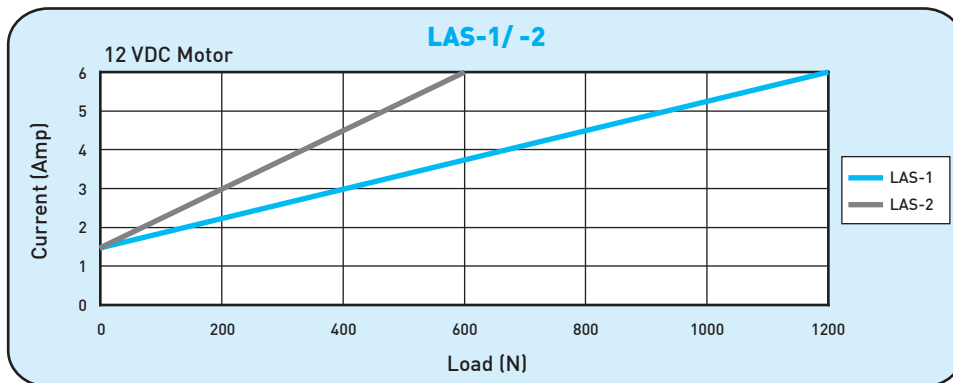

Note: The test results are obtained by using 12VDC power supply.

• Ordering Information

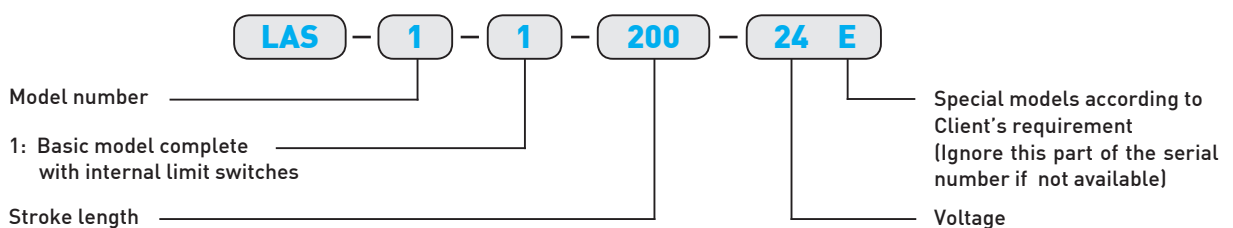

6.

HIWIN LAS Series (2)

LAS3



Screw type	ACME
Weight*	1.27 kg
Protection	IP 54
Compatible controller	LAK2
Working temp	+5°C ~-40°C

Position feedback specifications (Optical Sensor)		
Supply voltage	24VDC	12VDC
Output	High level 24VDC Low level 0.2v/40mA PNP* PS. Open collector	High level 12VDC Low level 0.2v/40mA PNP* PS. Open collector

* Stroke length 200 mm

- * Option: (1) IP65
 (2) position feedback
 (3) Potentiometer 10k ohm (RL=S+154)
 (4) NPN output (Optical sensor)
 (5) TTL output (Optical sensor)
 (6) 36VDC motor

• RL=S+146
 RL: Retracted length
 S: Stroke length

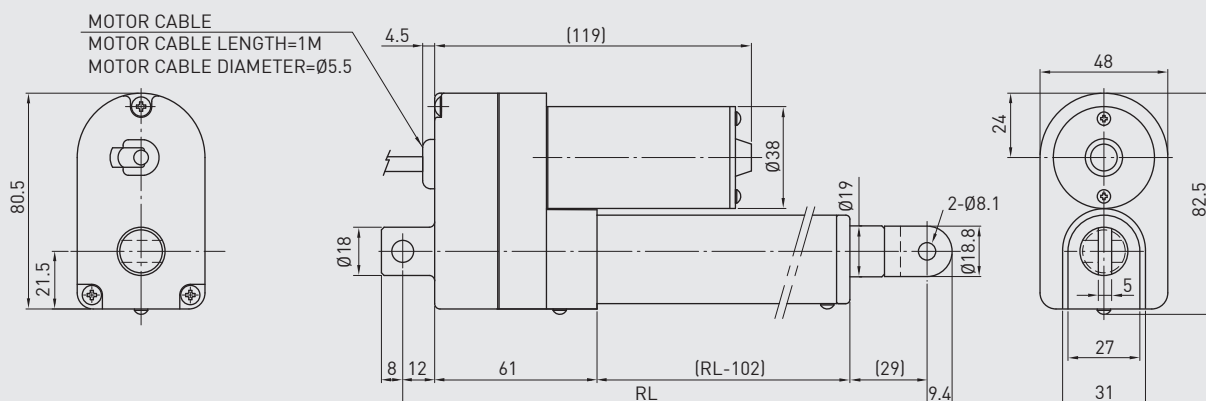

• LAS3 Specifications

Model	Thrust max. (N)	Pulling max. (N)	Holding max. (N)	Speed (mm/s)		Standard stroke (mm) : S					Duty cycle %	Max.current (A)		Optical Sensor Resolution (mm/pulse)	Potentiometer Resolution (Ohm/mm)
				Load=Max.	Load=0	50	100	150	200	250		12VDC	24VDC		
LAS3-1	1200	1200	800	8	12	50	100	150	200	250	10	6	2.5	0.3175	21
LAS3-2	600	600	300	16	25	50	100	150	200	250	10	6	3	0.635	10.5

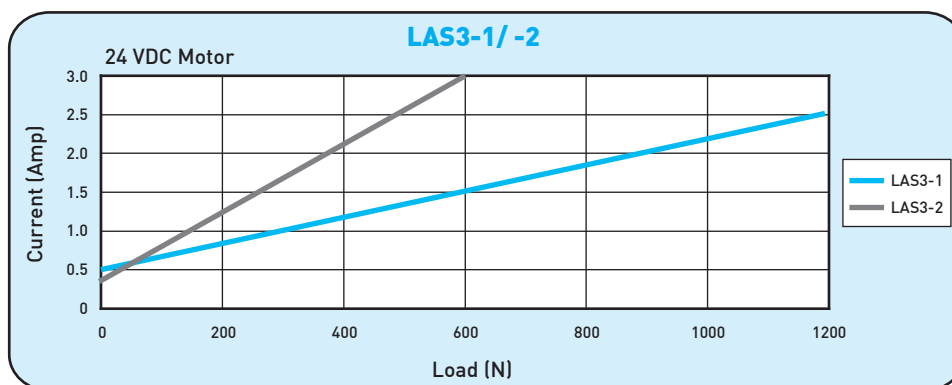
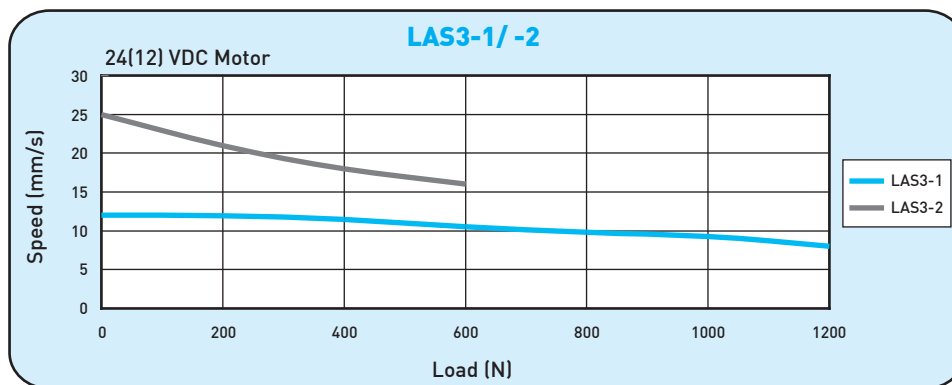

Note: The test results are obtained by using 24VDC power supply.

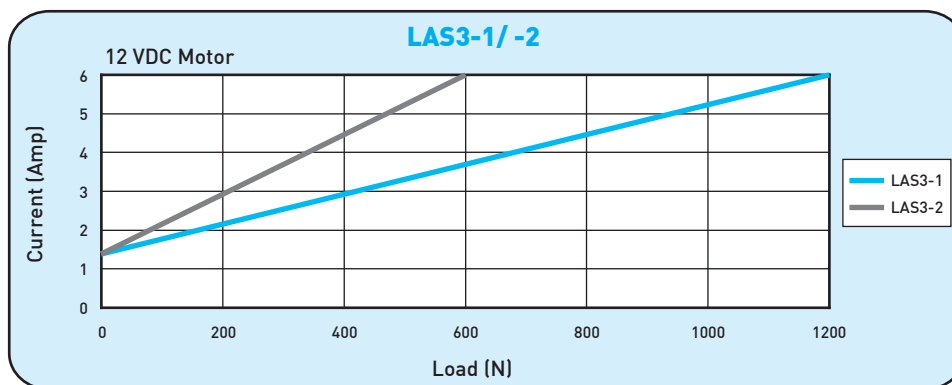

Note: The test results are obtained by using 12VDC power supply.

• Ordering Information

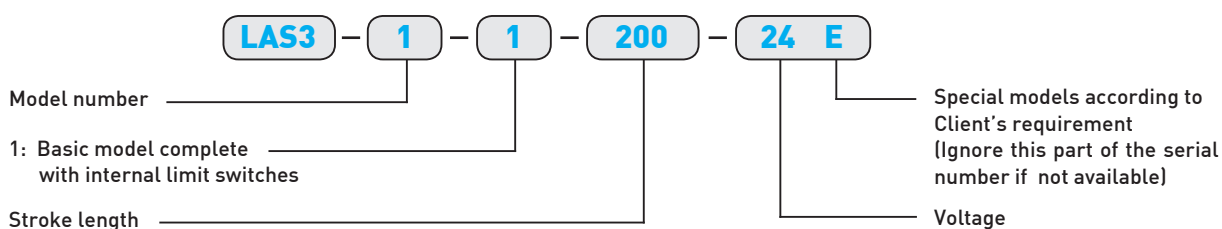

6.

HIWIN LAS4 Series

LAS4



Screw type	ACME
Weight*	1.36 kg
Protection	IP 54
Compatible controller	LAK2
Working temp	+5°C ~40°C

* Stroke length 200 mm

* Option: (1) IP65

- $RL=S+222.5$
RL: Retracted length
S: Stroke length

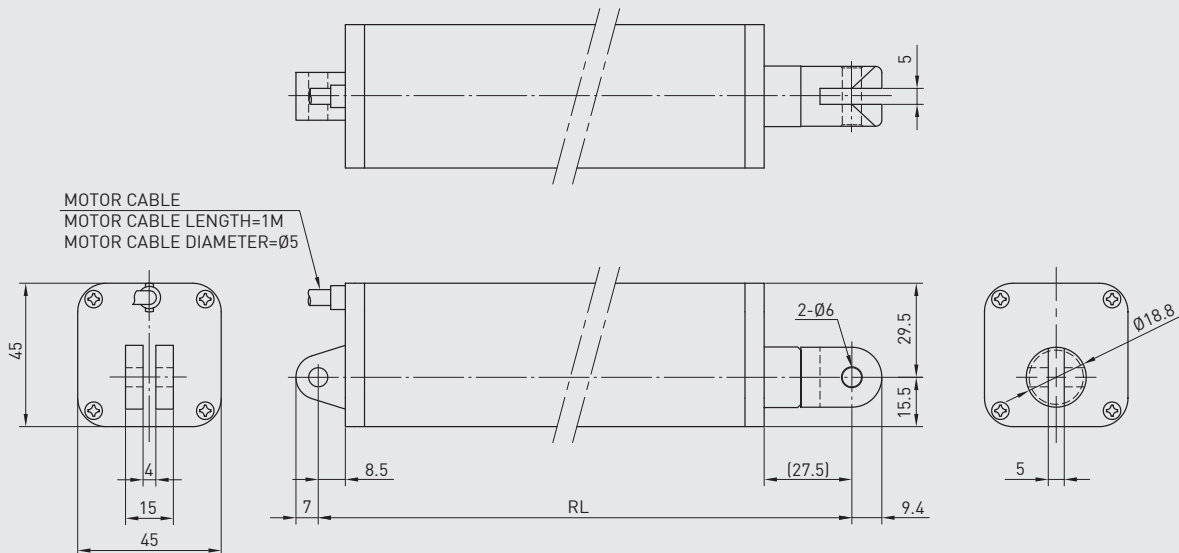

• LAS4 Specifications

Model	Thrust max. (N)	Pulling max. (N)	Holding max. (N)	Speed (mm/s)		Standard stroke (mm) : S					Duty cycle %	Max.current (A)	
				Load=Max.	Load=0	100	150	200	250	300		12VDC	24VDC
LAS4-1	800	800	800	10	15	100	150	200	250	300	10	5	2.3
LAS4-2	300	300	200	30	46	100	150	200	250	300	10	6	3.6

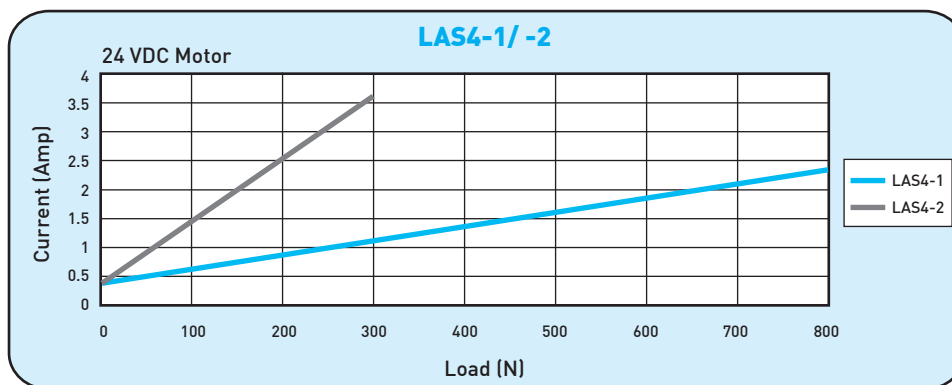
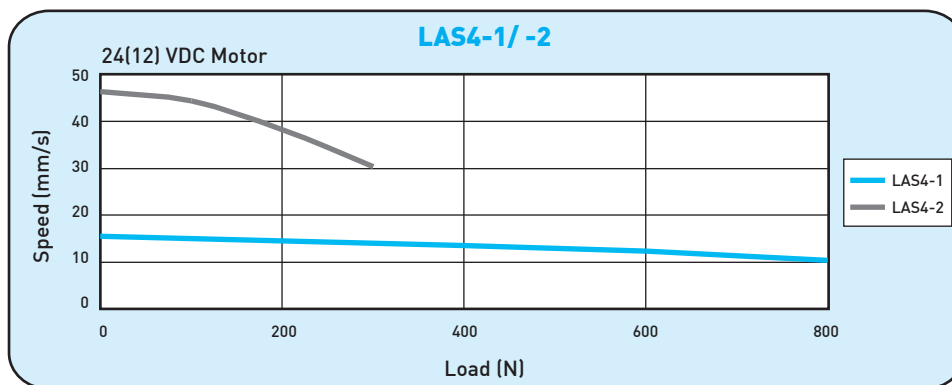

Note: The test results are obtained by using 24VDC power supply.

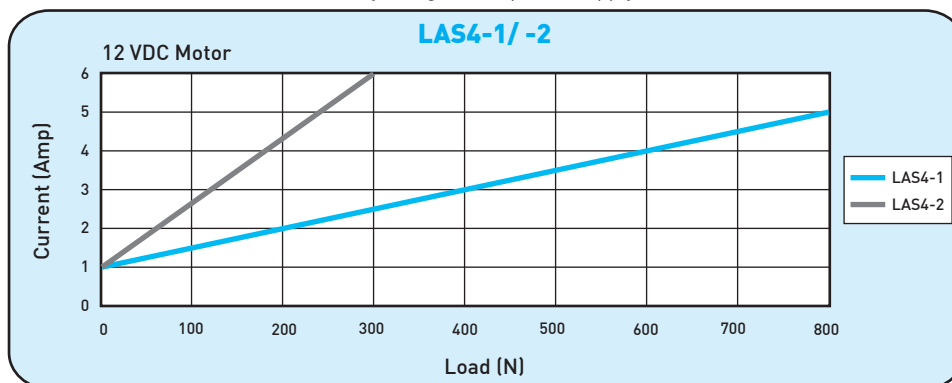

Note: The test results are obtained by using 12VDC power supply.

• Ordering Information

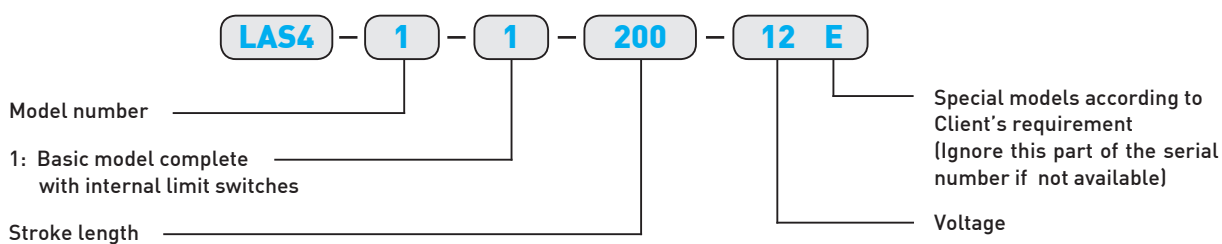

7.

HIWIN LAN Series (1)

LAN1

CE



Screw type	ACME
Weight*	2.6 kg
Protection	IP 54
Compatible controller	LAK2B/LAK2D LAK4/LAK6B
Working temp	+5°C ~-40°C

Position feedback specifications (Hall Sensor)			
Supply voltage	24VDC	12VDC	5VDC
Output	High level 24VDC Low level 0.2v/10mA sink (NPN)	High level 12VDC Low level 0.2v/10mA sink (NPN)	TTL

* Stroke length 200 mm

* Option: (1) IP66

(2) Position feedback

(3) Safety nut (RL=S+185)

(4) Mechanical Spline (push only)(RL=S+223)

(5) Back fixture turned 90°

(6) Mechanical quick release(RL=S+230), Only for LAN1-4 with motor cable outlet from back(C)

(7) Motor cable outlet : (A)Standard (B)Front (C)Back.

(8) 36VDC motor

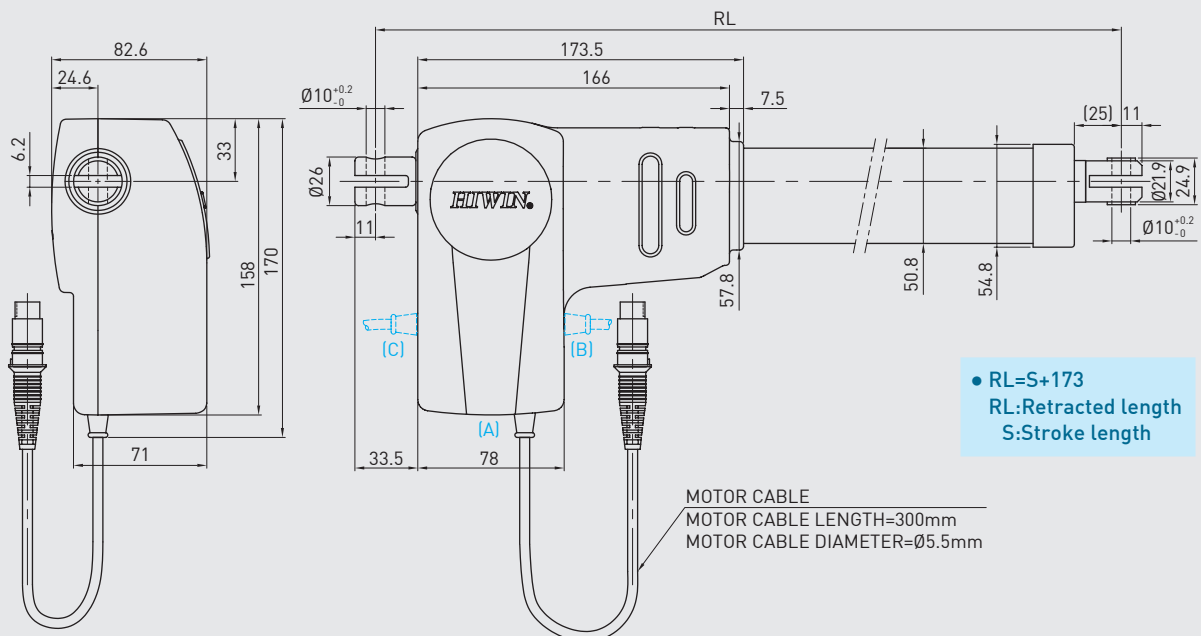

• LAN1 Specifications

Standard Motor

Model	Thrust max. (N)	Pulling max. (N)	Holding max. (N)	Speed (mm/s)		Standard stroke (mm) : S	Duty cycle %	Max.current (A) 24VDC	Hall Sensor Resolution (mm/pulse)
				Load=Max.	Load=0				
LAN1-1	6000	5000	5000	2.7	5	100 150 200 250 300	10	4	0.3
LAN1-2	4000	4000	4000	5	7	100 150 200 250 300	10	4	0.5

Note: The test results are obtained by using 24VDC power supply.

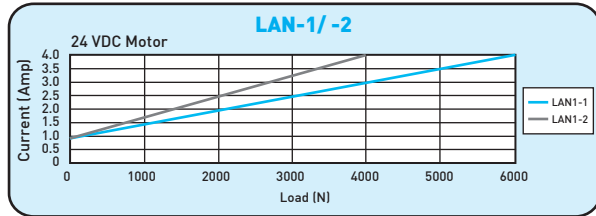
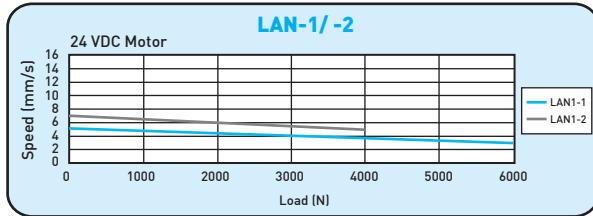

Fast Motor 24Q

Model	Thrust max. (N)	Pulling max. (N)	Holding max. (N)	Speed (mm/s)		Standard stroke (mm) : S	Duty cycle %	Max.current (A) 24VDC	Hall Sensor Resolution (mm/pulse)
				Load=Max.	Load=0				
LAN1-1	6000	5000	5000	5	7	100 150 200 250 300	10	6	0.3
LAN1-2	4000	4000	4000	7	9	100 150 200 250 300	10	6	0.4
LAN1-3	3000	3000	3000	9	11.5	100 150 200 250 300	10	6	0.5
LAN1-4	2000	2000	2000	10	13.5	100 150 200 250 300	10	5.5	0.8

Note: The test results are obtained by using 24VDC power supply.

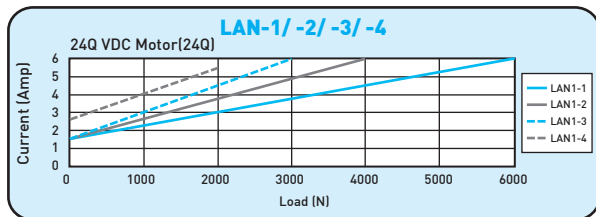
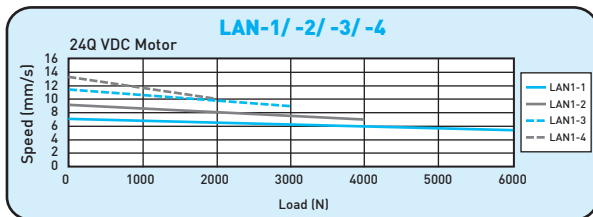

12VDC Motor

Model	Thrust max. (N)	Pulling max. (N)	Holding max. (N)	Speed (mm/s)		Standard stroke (mm) : S	Duty cycle %	Max.current (A) 12VDC	Hall Sensor Resolution (mm/pulse)
				Load=Max.	Load=0				
LAN1-1	5000	5000	5000	3	6	100 150 200 250 300	10	11	0.3
LAN1-2	4000	4000	4000	3	8	100 150 200 250 300	10	11	0.4
LAN1-3	3000	3000	3000	5	10	100 150 200 250 300	10	10	0.5

Note: The test results are obtained by using 12VDC power supply.

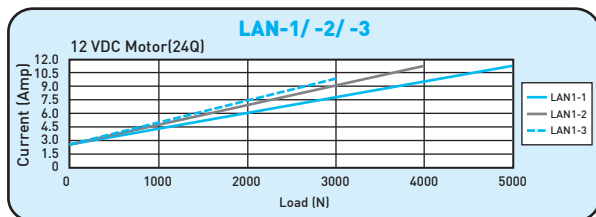
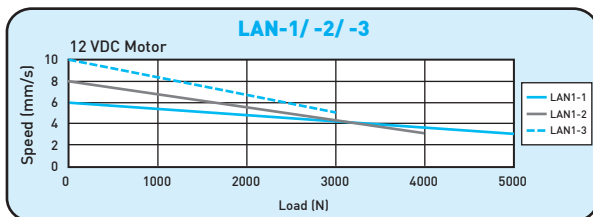

• Ordering Information

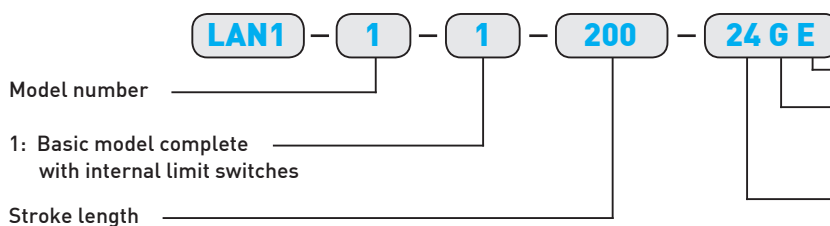

Special models according to Client's requirement (Ignore this part of the serial number if not available)

Color
B : Black
G : Gray

Voltage
24 : Standard
24Q : 24VDC (Quick)
12 : 12VDC Standard

7.

HIWIN LAN Series (2)

LAN2



Screw type	ACME
Weight*	3.29 kg
Protection	IP 54
Compatible controller	LAK2/LAK2LR
Working temp	+5°C ~40°C

Position feedback specifications (Hall Sensor)		
Supply voltage	24VDC	5VDC
Output	High level 22VDC Low level 0.2v/10mA sink (NPN)	TTL

* Stroke length 300 mm

- * Option: (1) IP66
 (2) position feedback
 (3) Safety nut: RL=S+211
 (4) Spline(push only): RL=S+237

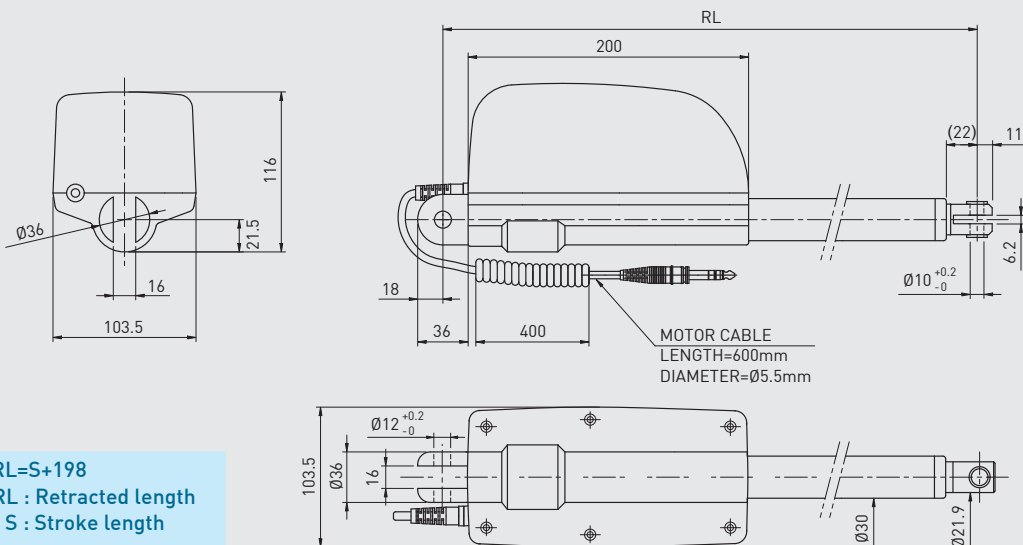

- RL=S+198
 RL : Retracted length
 S : Stroke length

• LAN2 Specifications

Model	Screw type	Thrust max. (N)	Holding max. (N)	Speed (mm/s)		Standard stroke (mm) : S						Duty cycle %	Max.current (A) 24VDC	Hall Sensor Resolution (mm/pulse)	
				Load=Max.	Load=0	100	150	200	250	300	350				400
LAN2-1A	ACME	6000	5000	4	6	100	150	200	250	300	350	400	10	6	0.3
LAN2-2A	ACME	5000	5000	5	7.5	100	150	200	250	300	350	400	10	6	0.4
*LAN2-3A	ACME	3000	3000	9	14	100	150	200	250	300	350	400	10	6	0.8

* LAN2/-3A Holding Force (Push direction only).

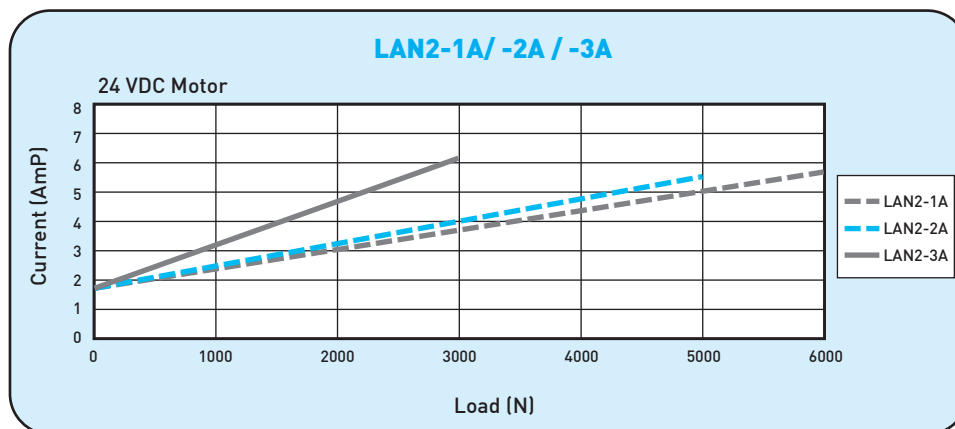
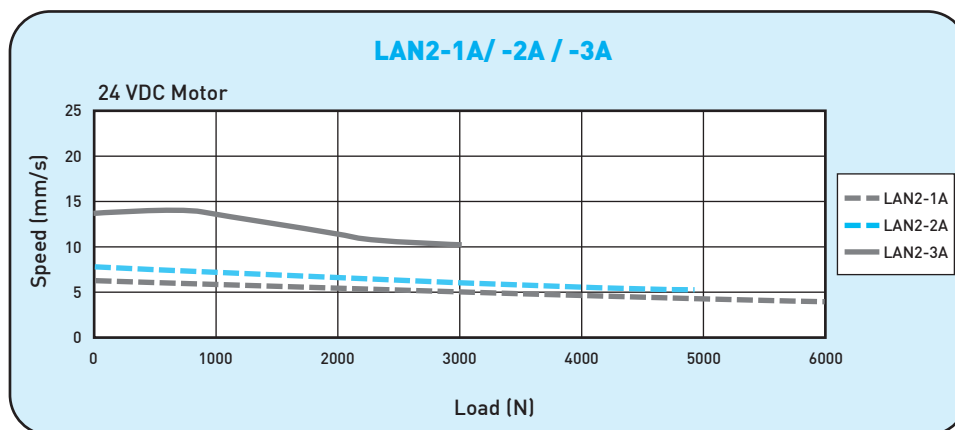

Note: The test results are obtained by using 24VDC power supply.

• Ordering Information

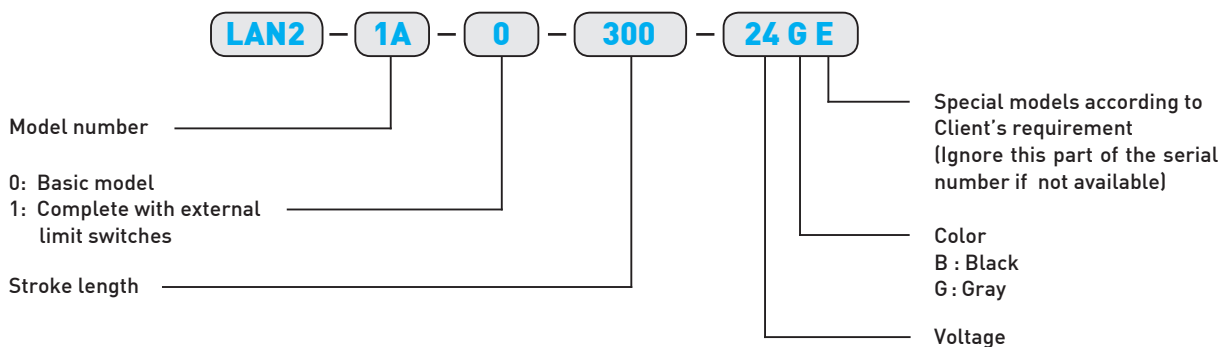

7.

HIWIN LAN Series (3)

LAN3



Screw type	ACME
Weight*	5.31 kg
Protection	IP 54
Compatible controller	LAK6B/LAK2J
Working temp	+5°C ~40°C

* Stroke length 200 mm

* Option: (1) IP66

- (2) potentiometer 10K ohm (RL=S+221, S < 200mm / RL= S+272, S:200~500mm)
- (3) Mechanical spline (RL=S+252, S < 200mm / RL= S+302, S:200~500mm)
- (4) Safety Nut (RL=S+222, S < 200mm / RL= S+272, S:200~500mm)
- (5) Mechanical quick release
- (6) Back fixture turned 90°
- (7) Fast motor 24Q
- (8) 36VDC motor

- RL=S+210
Stroke < 200
- RL=S+260
(Stroke:200~500mm)
RL:Retracted length
S:Stroke length

MOTOR CABLE
MOTOR CABLE LENGTH=1M
MOTOR CABLE DIAMETER=Ø5.5mm

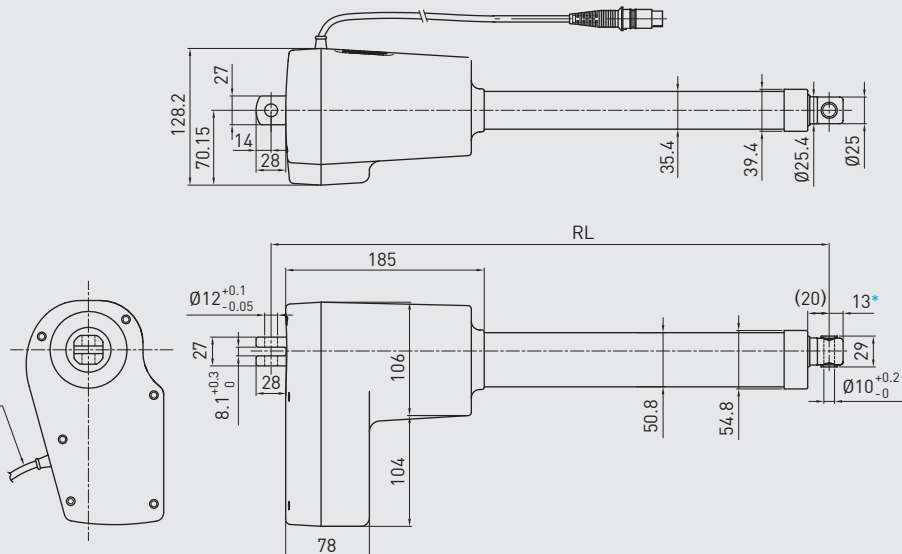

• LAN3 Specifications

Model	Thrust max. (N)	Pulling max. (N)	Holding max. (N)	Speed (mm/s)		Standard stroke (mm) : S								Duty cycle %	Max.current (A) 24VDC	Potentiometer Resolution (Ohm/mm)	
				Load=Max.	Load=0	110	150	200	250	300	350	400	450				500
LAN3-1	10000	6000	10000	5	8	110	150	200	250	300	350	400	-	-	10	8.3	37.5
LAN3-2	7000	6000	7000	7	9	110	150	200	250	300	350	400	450	500	10	7	28
LAN3-3	5000	5000	5000	9.5	12.5	110	150	200	250	300	350	400	450	500	10	7	22.5

* Stroke over 200mm(included), RL=S+260

* The max. stroke lengths with potentiometer : LAN3-1 Max.250mm, LAN3-2 Max.330mm, LAN3-3 Max.420mm

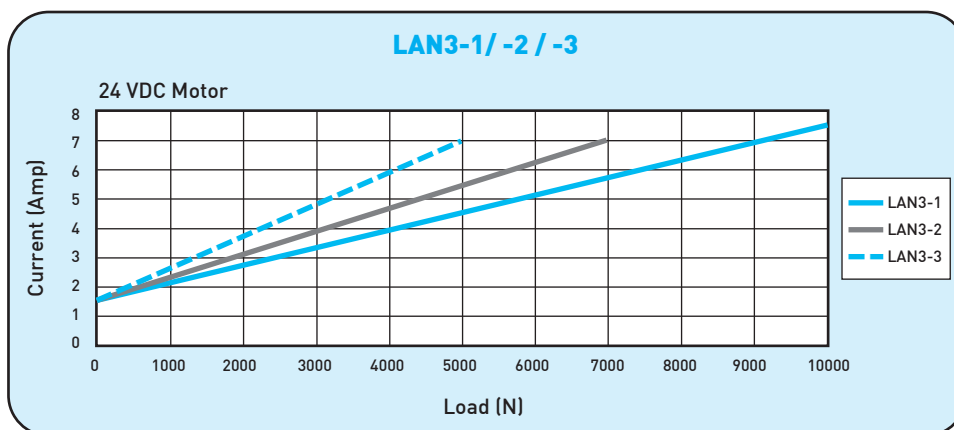
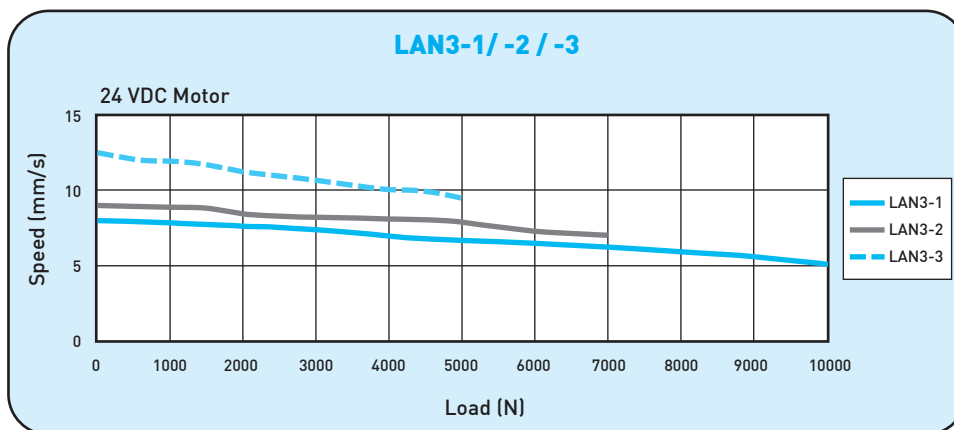

Note: The test results are obtained by using 24VDC power supply.

• Ordering Information

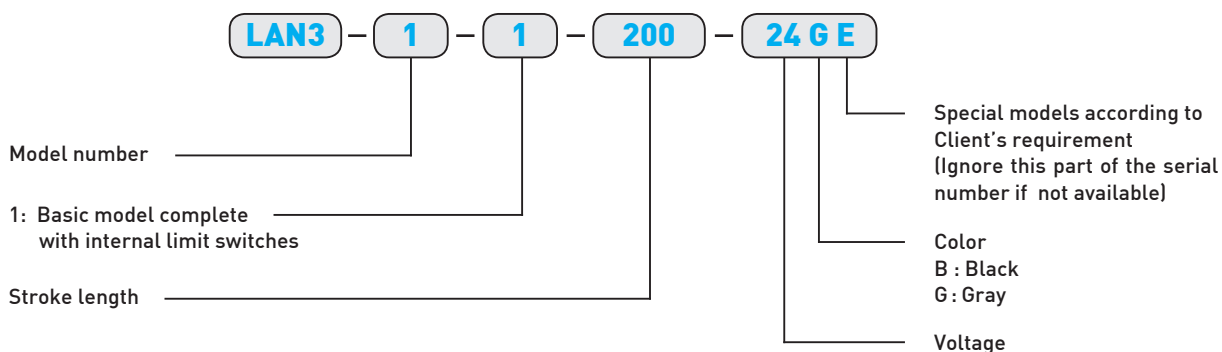

7.

HIWIN LAN Series (4)

LAN4

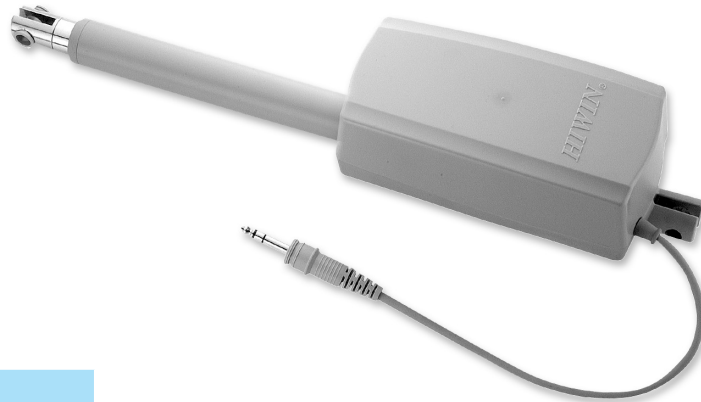

Screw type	ACME
Weight*	2.33 kg
Protection	IP 54
Compatible controller	LAK2/LAK2LR
Working temp	+5°C ~40°C

* Stroke length 200 mm

* Option: (1) IP66

(2) Safety Nut RL=S+174

- RL=S+160
RL: Retracted length
S: Stroke length

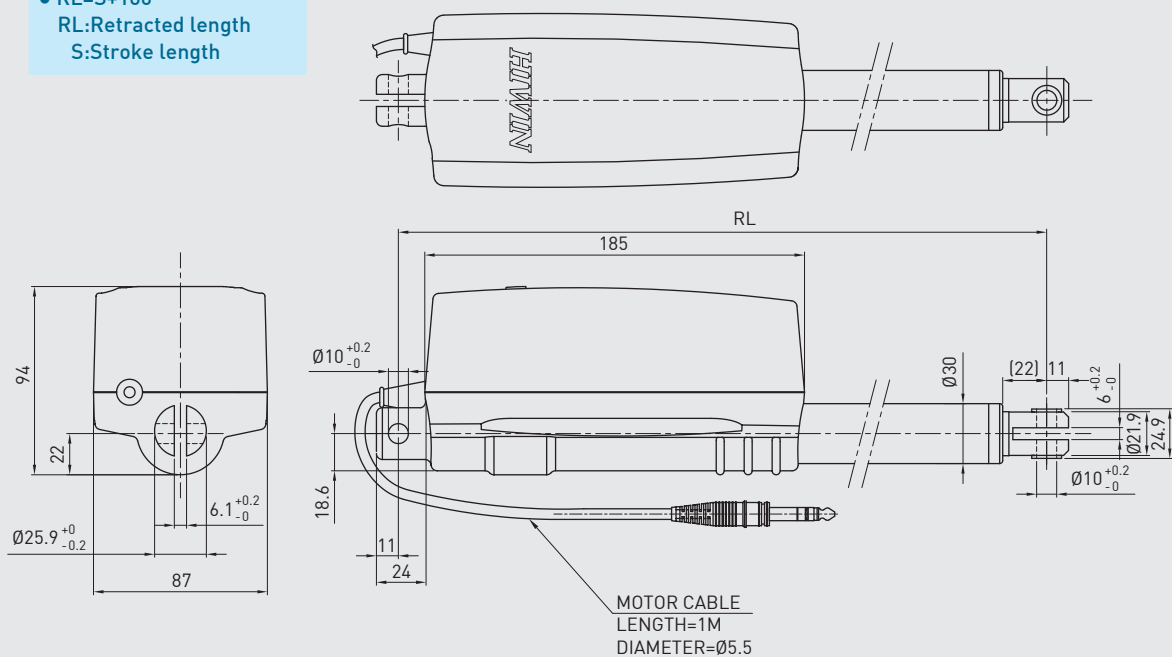

• LAN4 Specifications

Model	Thrust max. (N)	Pulling max. (N)	Holding max. (N)	force (mm/s)		Standard stroke (mm) : S							Duty cycle %	Max.current (A)	
				Load=Max.	Load=0	100	150	200	250	300	350	400		24VDC	12VDC
LAN4-1	3500	3500	3500	4	7	100	150	200	250	300	350	400	10	5	12
LAN4-2	3000	3000	3000	5	9	100	150	200	250	300	350	400	10	5	12
LAN4-3	2000	2000	2000	7	13	100	150	200	250	300	350	400	10	5	12
LAN4-4	1500	1500	1500	11	20	100	150	200	250	300	350	400	10	5	12

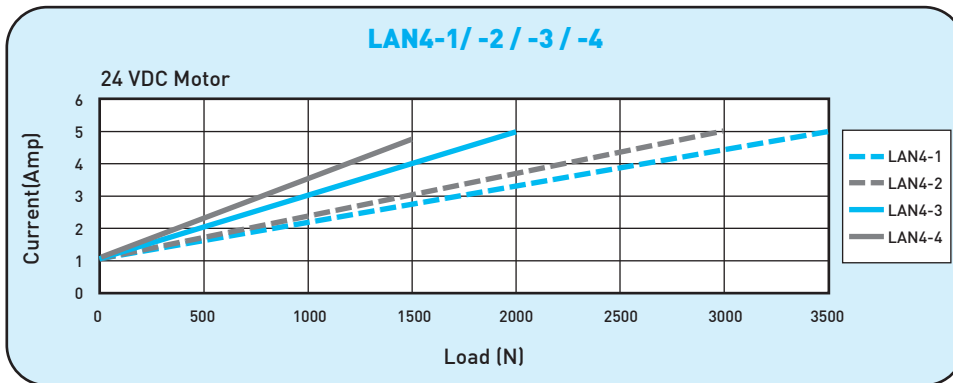
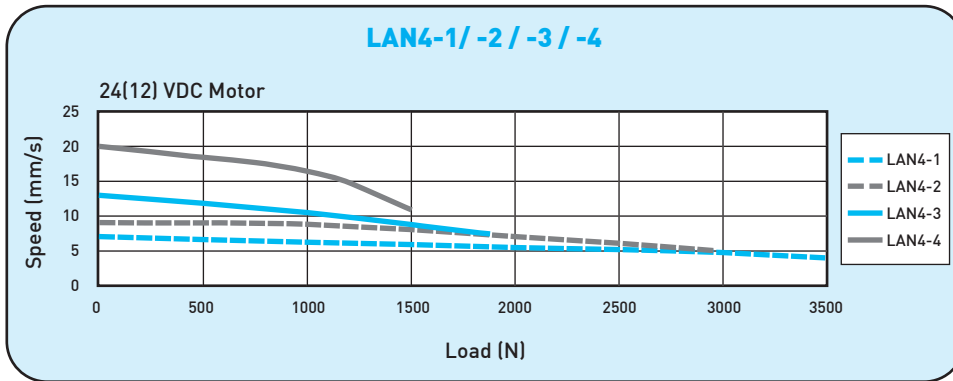

Note: The test results are obtained by using 24VDC power supply.

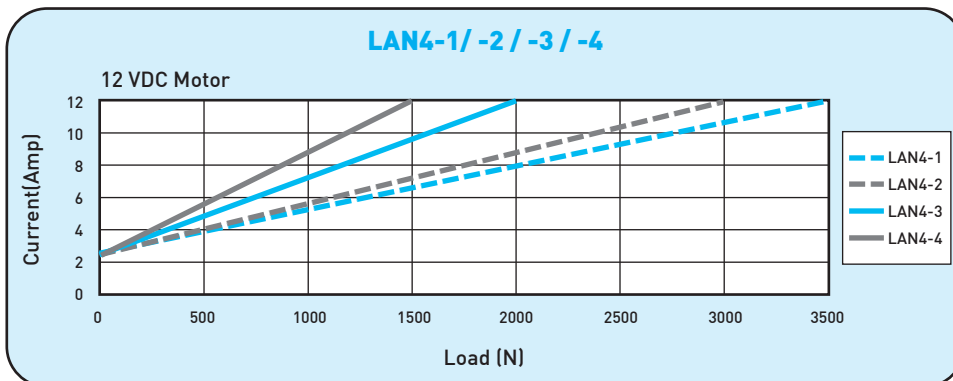

Note: The test results are obtained by using 12VDC power supply.

• Ordering Information

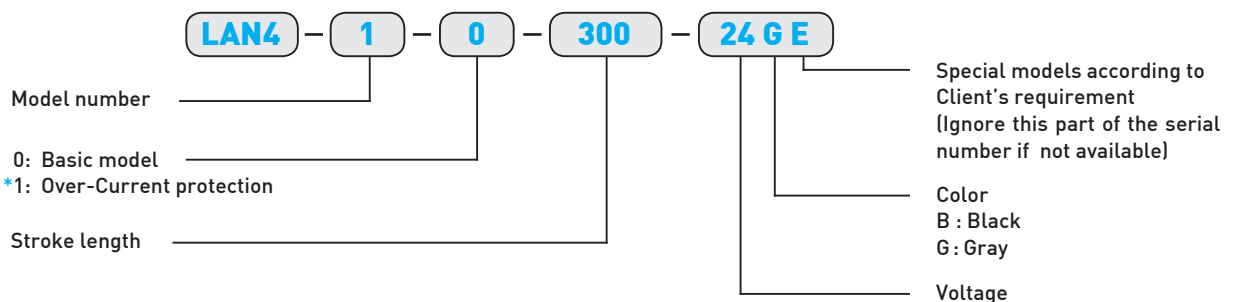

*Remark : Completed with internal over-current protection circuitry to ensure Actuator stops if obstacles or stroke limits are reached.

8.

HIWIN 1-Axis Controller

LAK2LR

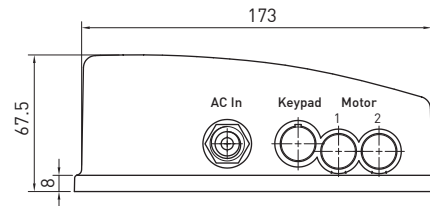
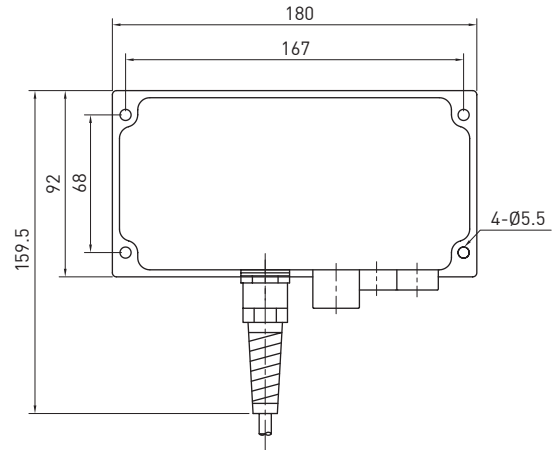

Input voltage	AC 100/110/220/230V
Output power	108VA(24VDC)max
Duty cycle	10%
Working temp	+5°C ~40°C
Protection*	IP 54

* Option: IP66

• Features of LAK2LR

- Control 1 Actuator with external limit switches.
- OLP (Over Load Protection)
- ESS (Enhanced Spark Suppression)
- Standard cable length: 4M
- Relay connecting point protection.

• For Series LAM, LAN2 completed with external limit switches

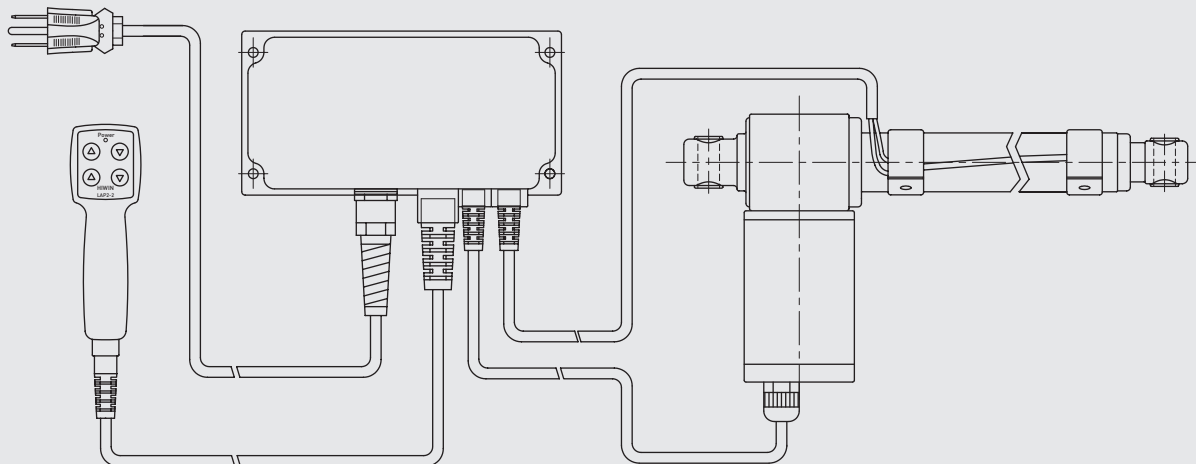

• Ordering Information

LAK2LR - G - 110 - B E

Special models according to Client's requirement	None E=Ignore this part of the serial number if not available
Color	B : Black G : Gray
Input Voltage	100 : AC100V ; 110 : AC110V 220 : AC220V ; 230 : AC230V
Actuator No. 1	G : LAM-1/-2/-1A ; LAN2

* Check attached table for over current setting...see page 39.
* The keypad of the LAK2LR is not the same as LAK2L.

9.

HIWIN 2-Axis Controller

LAK2

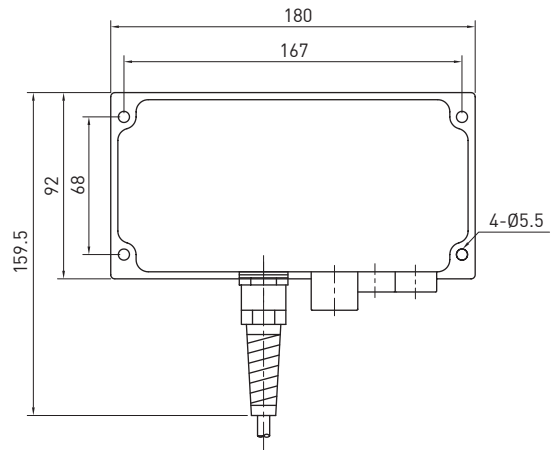

Input voltage	AC 100/110/220/230V
Output power	108VA(24VDC)max
Duty cycle	10%
Working temp	+5°C ~40°C
Protection*	IP 54

* Option: (1) IP66
(2) DC 12V / 24V In & Out

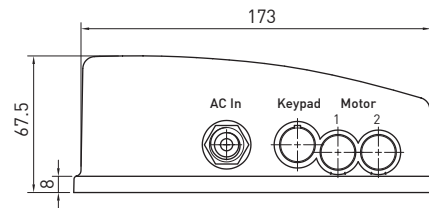

• Features of LAK2

- Control 1 or 2 Linear Actuators
- Over current protection
- Standard cable length: 4M

• For Series LAS, LAS3, LAS4, LAM, LAN2 (AC IN)

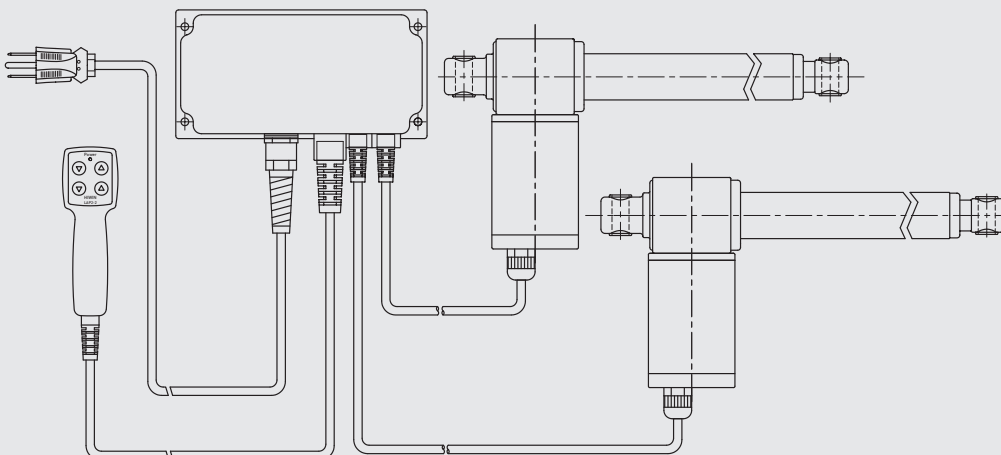

• **Ordering Information**

LAK2 - B 0 - 110 - B E

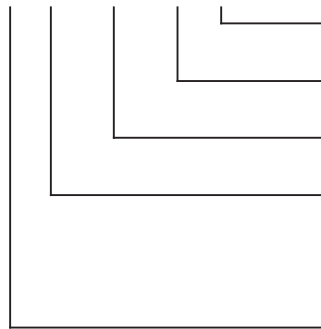

Special models according to Client's requirement	None E=Ignore this part of the serial number if not available
Color	B : Black G : Gray
Input Voltage	100 : AC100V ; 110 : AC110V 220 : AC220V ; 230 : AC230V
Actuator No. 2	0 : NO A : LAS4-1 B : LAS-1 ; LAS3-1 C : LAS-2 ; LAS3-2 ; LAS4-2 G : LAM-1/-2/-1A ; LAN2
Actuator No. 1	A : LAS4-1 B : LAS-1 ; LAS3-1 C : LAS-2 ; LAS3-2 ; LAS4-2 G : LAM-1/-2/-1A ; LAN2

LAK2 - E 0 - 12 - B E

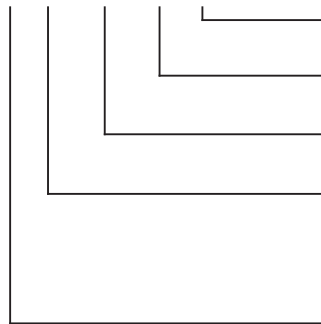

Special models according to Client's requirement	None E=Ignore this part of the serial number if not available
Color	B : Black G : Gray
Input Voltage	12 : 12VDC 24 : 24VDC
Actuator No. 2	0 : NO A : LAS4-1 B : LAS-1 ; LAS3-1 C : LAS-2 ; LAS3-2 ; LAS4-2 E : LAS-1(12V) ; LAS3-1(12V) ; LAS4-1(12V) F : LAS-2(12V) ; LAS3-2(12V) G : LAM-1/-2/-1A ; LAN2 L : LAN1-1/-2/-3(12V) ; LAM-1/-2/-1A
Actuator No. 1	A : LAS4-1 B : LAS-1 ; LAS3-1 C : LAS-2 ; LAS3-2 ; LAS4-2 E : LAS-1(12V) ; LAS3-1(12V) ; LAS4-1(12V) F : LAS-2(12V) ; LAS3-2(12V) G : LAM-1/-2/-1A ; LAN2 L : LAN1-1/-2/-3(12V) ; LAM-1/-2/-1A

*Standard cable:1M in length with 3 flying lead termination

9.

HIWIN 2-Axis Controller

LAK2B



(1) For 1.3Ah Battery

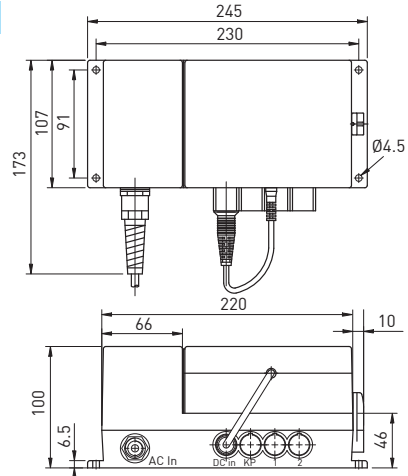

(2) For 2.9Ah Battery

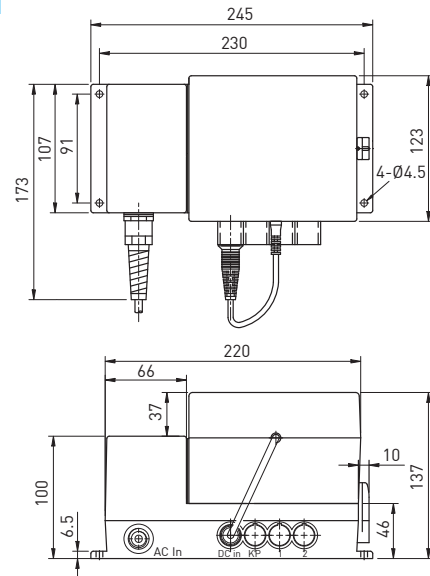

Input voltage	AC 100/110/220/230V
Output power	144VA(24VDC)max
Duty cycle	10%
Working temp	+5°C ~40°C
Protection*	IP 54

* Option: (1) IP66
(2) Custom program

• Features of LAK2B

- Control 1 or 2 Linear Actuators
- Compact size
- Over load protection
- Soft - start/stop
- Standard cable length : 4 M
- Rechargeable Battery
- Low battery indicator (alarm)
- Battery capacity : 1.3 Ah (12VDCx2)
(Option:2.9Ah, 12VDCx2)

*Note: Please charge battery for at least 8 hours before initial use.

Current vs. Durable Period under Load (1.3Ah)

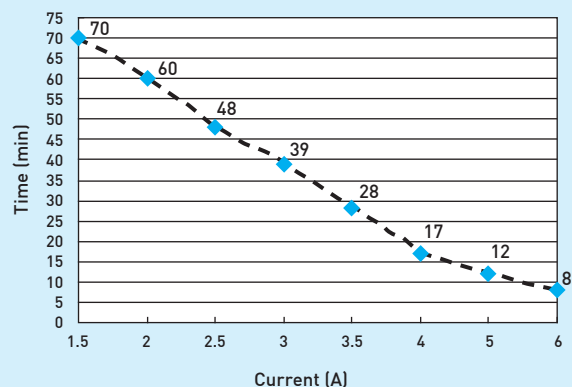

• For Series LAS4, LAN1 and LAM3

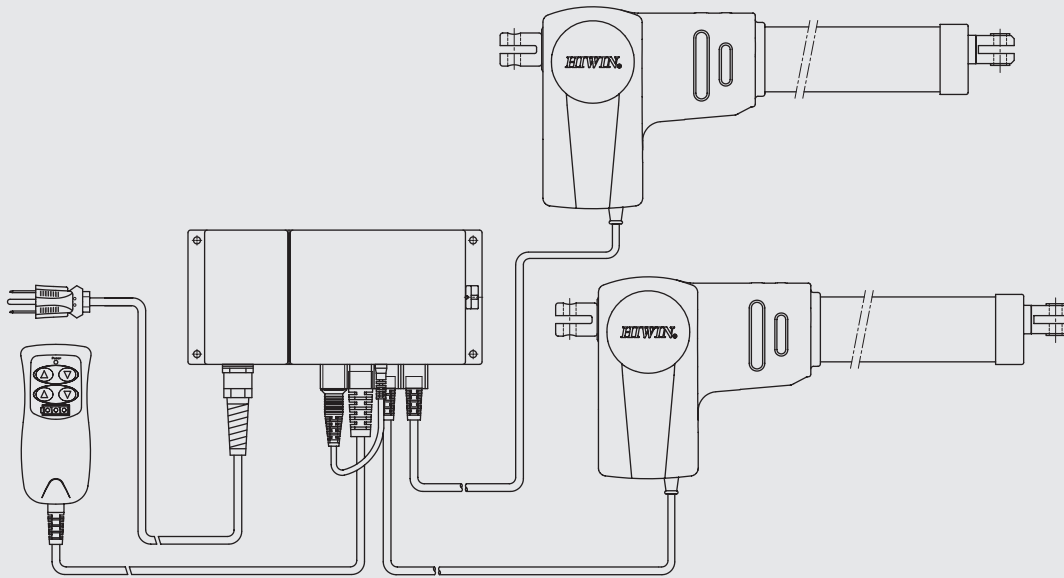

• Ordering Information (LAK2B)

LAK2B - 1 - D 0 - 110 - B E

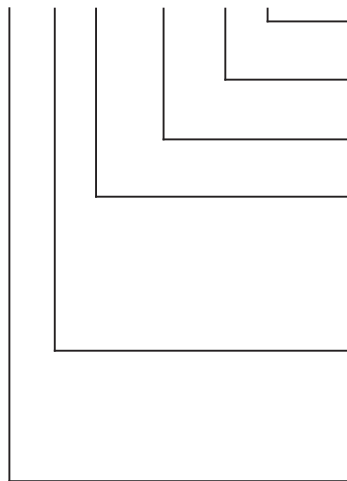

Special models according to Client's requirement	None E=Ignore this part of the serial number if not available
Color	B : Black G : Gray
Input Voltage	100 : AC100V ; 110 : AC110V 220 : AC220V ; 230 : AC230V
Actuator No. 2	0 : NO A : LAS4-1 C : LAN1-1/-2 D : LAM3-3/-4 E : LAM3-2 F : LAN1-1/-2/-3(24Q) ; LAM3-1
Actuator No. 1	A : LAS4-1 C : LAN1-1/-2 D : LAM3-3/-4 E : LAM3-2 F : LAN1-1/-2/-3(24Q) ; LAM3-1
Battery	0 : No 1 : 1.3Ah 2 : 2.9Ah

* Check attached table for over current setting...see page 39.

• Ordering Information (Battery)

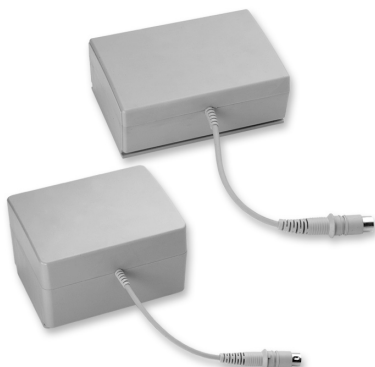

LAKB - 1 - G E

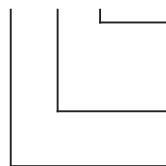

Special models according to Client's requirement	None E=Ignore this part of the serial number if not available
Color	B : Black G : Gray
Battery	1 : 1.3Ah 2 : 2.9Ah

9.

HIWIN 2-Axis Controller

LAK2D



Input voltage	AC 100/110/220/ 230V(50/60Hz)
Output power	108VA(24VDC)max
Duty cycle	10%
Working temp	+5°C ~40°C
Protection*	IP 54

* Option: IP66

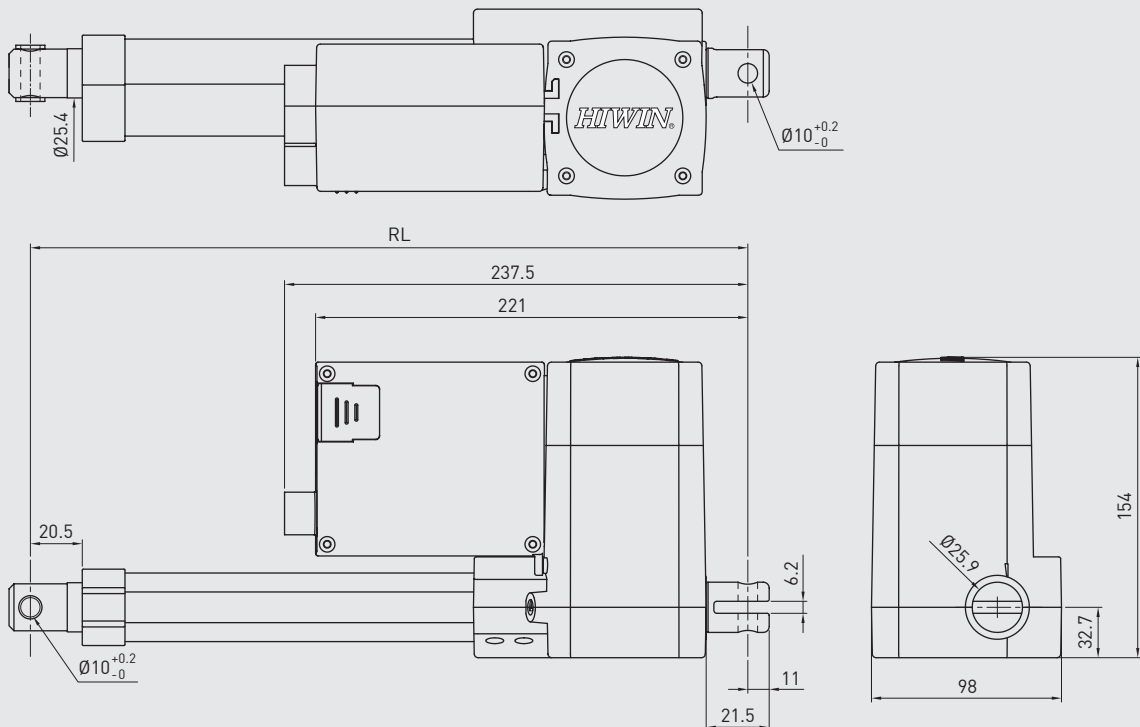

• **Features of LAK2D**

- Control 1 or 2 Linear Actuators
- Standard cable length: 4 M
- Over current protection
- During an emergency power loss, please insert 2- 9V alkaline batteries to lower the actuators. (Protection class is IP54 when LAK2D is optioned with batteries)
- Can be mounted directly on LAM3

• **For Series LAM3 and LAN1:**

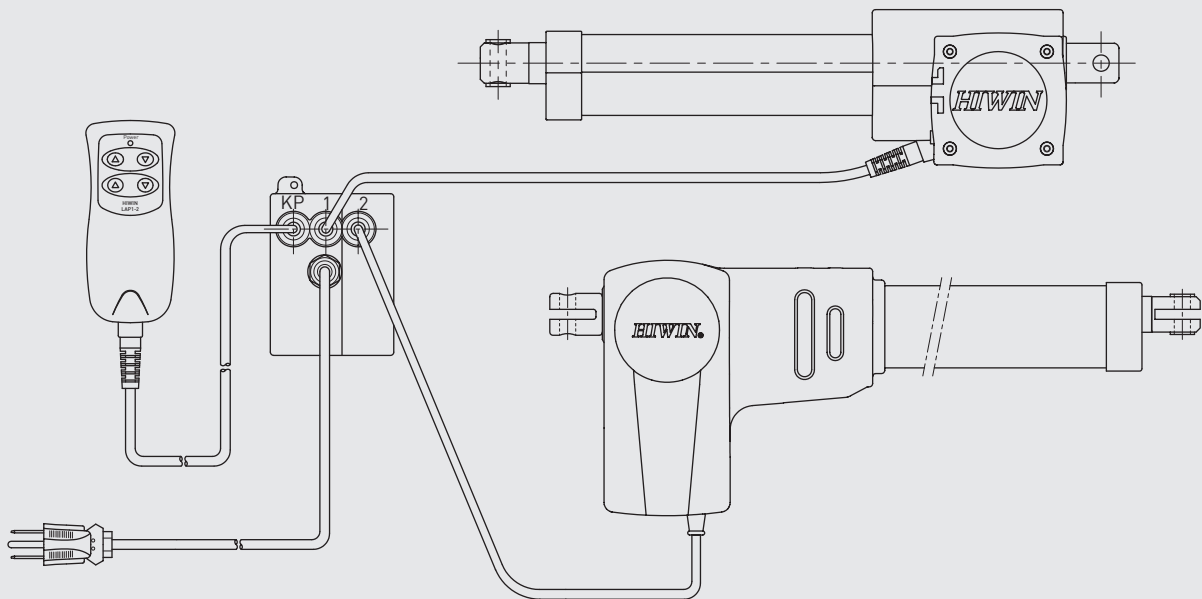

• **Ordering Information**

LAK2D - 1 - D 0 - 110 - G E

Special models according to Client's requirement	None E=Ignore this part of the serial number if not available
Color	B : Black G : Gray
Input Voltage	100 : AC100V ; 110 : AC110V 220 : AC220V ; 230 : AC230V
Actuator No. 2	0 : NO C : LAN1-1/-2 D : LAM3-3/-4 E : LAM3-2 F : LAN1-1/-2/-3(24Q) ; LAM3-1
Actuator No. 1	C : LAN1-1/-2 D : LAM3-3/-4 E : LAM3-2 F : LAN1-1/-2/-3(24Q) ; LAM3-1
Battery	0 : No 1 : 9-volt alkaine battery

* Check attached table for over current setting...see page 39.

9.

HIWIN 2-Axis Controller

LAK2J



Output power	DC 24V
Duty cycle	10%
Working temp	+5°C ~40°C
Protection*	IP 54

* Option: (1) IP65
(2) Customized software

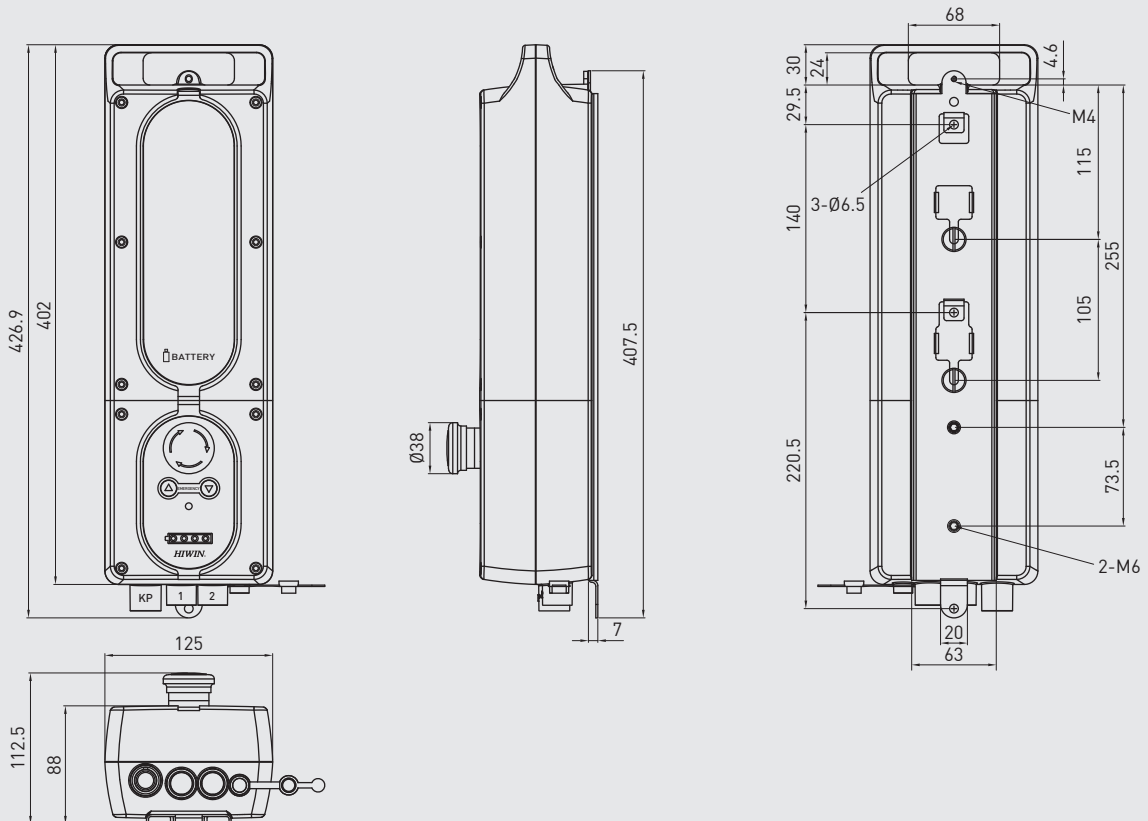

• Features of LAK2J

- Portable design (operated by battery)
- Control 1 to 2 Linear Actuators
- Emergency stop button
- Emergency operation through front panel
- Over current protection
- Soft - start / stop
- Battery rechargeable via LAKCH charger
- Automatic alarm when the battery is low
- Automatic Energy Saving Mode
- Battery capacity 4.5 Ah(12VDC*2)
- LED for power indication

*Note : Please fully charge the battery for 12hr the first time using LAK2J

• Battery Characteristics

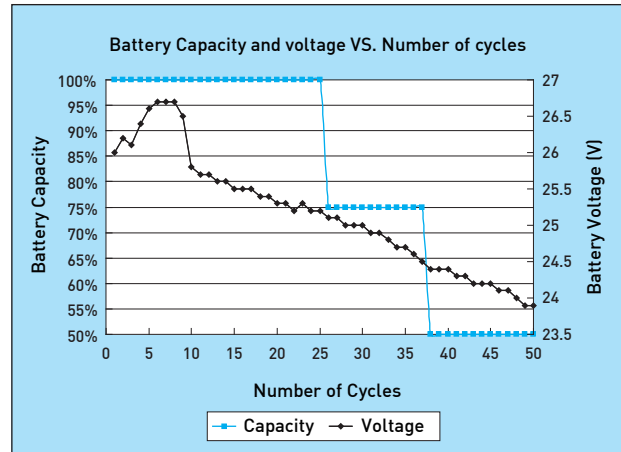

*Test results are obtained under 5A load current

• For series LAN3 and LAN1

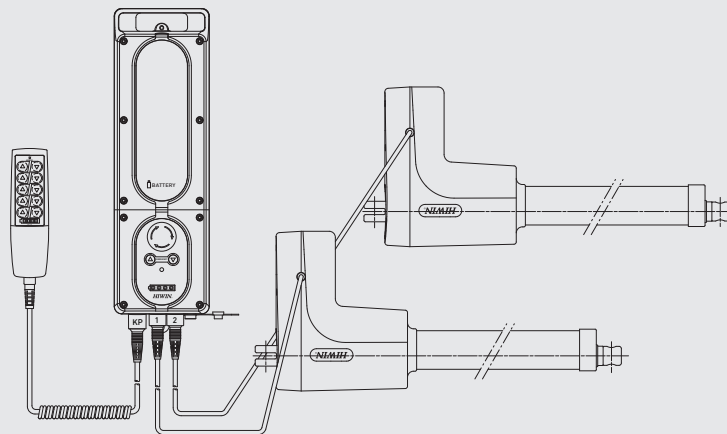

• Ordering Information

LAK2J - 1 - HH - 01 - 24 - W - E

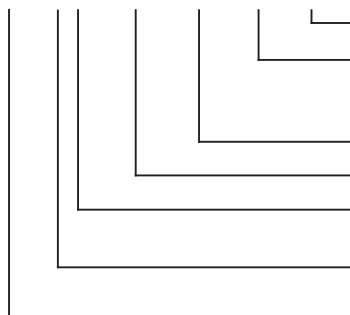

Special models according to Client's requirement	None E=Ignore this part of the serial number if not available
Color	B : Black G : Gray W : White
Output power	DC : 24V
Software function	01 : Standard
Actuator No.2	C : LAN1-1/-2 H : LAN3
Actuator No.1	C : LAN1-1/-2 H : LAN3
Battery type	1 : 4.5Ah

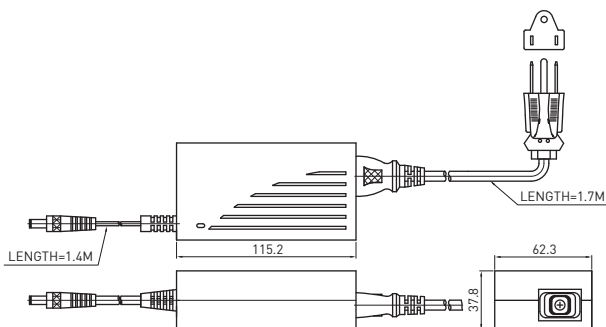

• Ordering Information

LAKCH - A - 24 - B

Color	B : Black
Output power	DC : 24V
Model	

10.

HIWIN 3-Axis Controller

LAK4

CE



Input voltage	AC 100/110/220/ 230V(50/60Hz)
Output power	72.5VA(24VDC)max
Duty cycle	10%
Working temp	+5°C ~40°C
Protection*	IP 54

* Option: IP66

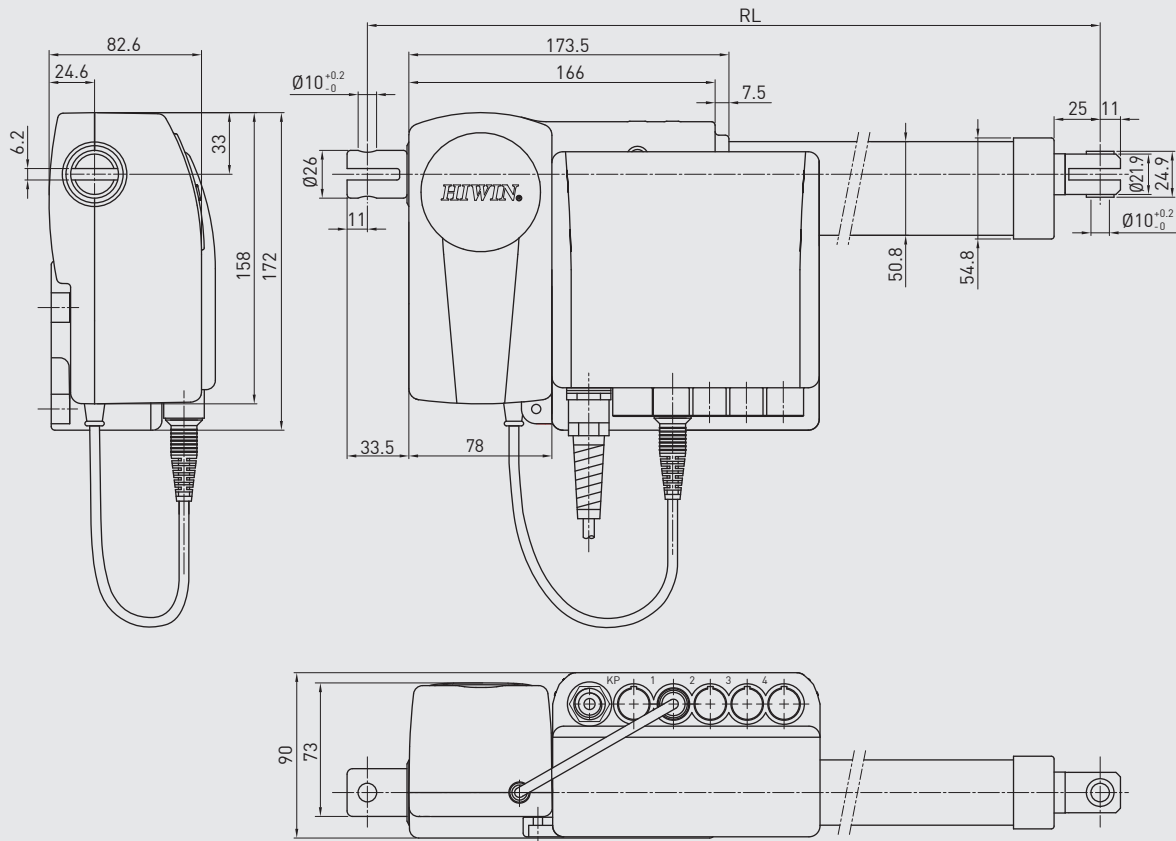

• **Features of LAK4**

- Control 1 to 3 Actuators
- Can be mounted directly on LAN1
- Standard cable length: 4M

• **For Series LAM3 and LAN1:**

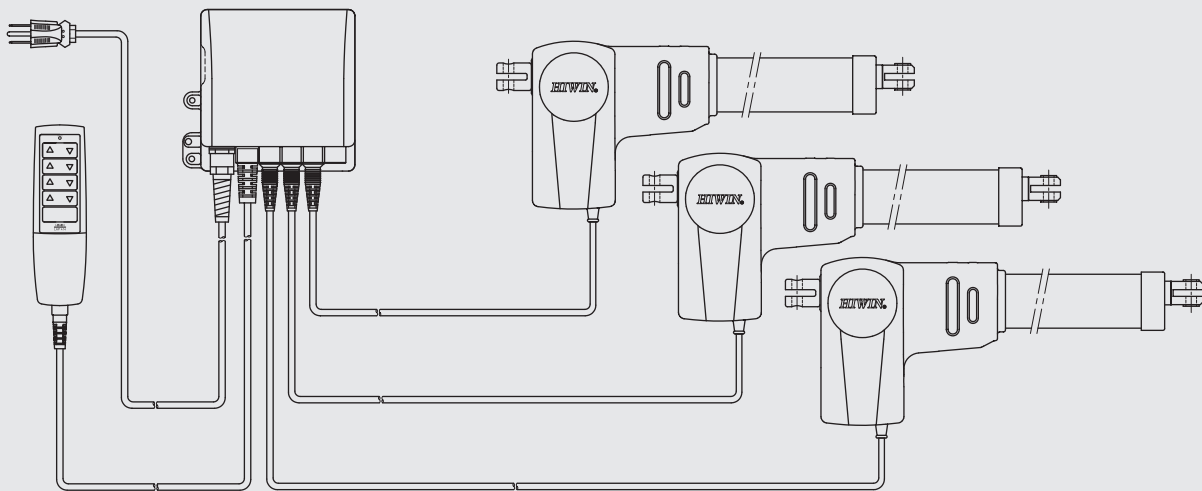

• **Ordering Information**

LAK4 - D 000 - 110 - B E

Special models according to Client's requirement	None E=ignore this part of the serial number if not available
Color	B : Black G : Gray
Input Voltage	100 : AC100V ; 110 : AC110V 220 : AC220V ; 230 : AC230V
Actuator No. 2 ~ No. 3	0 : NO C : LAN1-1/-2 D : LAM3-3/-4 F : LAN1-1/-2/-3(24Q)
Actuator No. 1	C : LAN1-1/-2 D : LAM3-3/-4 F : LAN1-1/-2/-3(24Q)

Note: Please select LAK4N for 4 axis application.

10.

HIWIN 4-Axis Controller

LAK4N



Input voltage	AC 100/110/220/230V
Output power	216VA(DC 24V)Max
Duty cycle	10%
Working temp	+5°C ~40°C
Protection*	IP 54

* Option: IP66

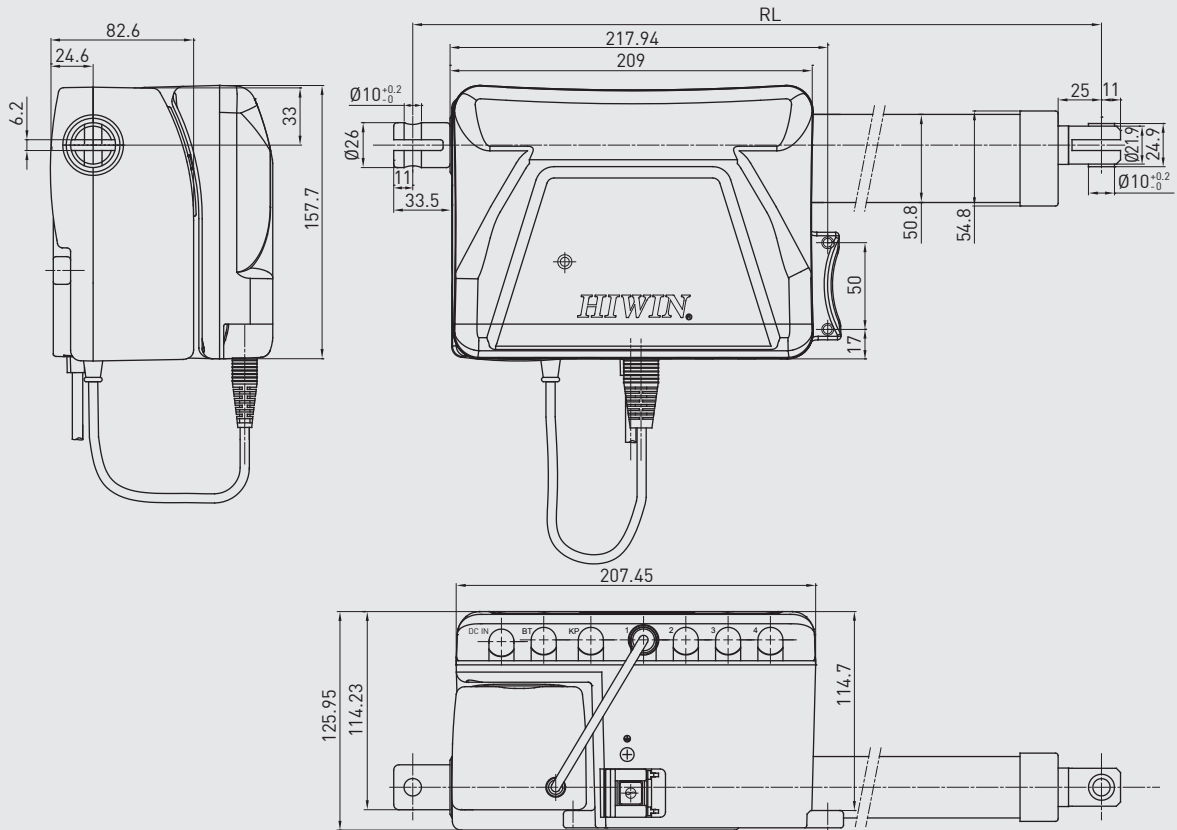

• **Features of LAK4N**

- Control 1 to 4 Linear Actuators
- Over current protection
- Standard cable length 4M
- Removable AC power cable
- Detachable cable retainer for accidental unplugging protection
- Soft - start / stop
- LED for power indication
- External battery input
- External DC input
- Can be mounted directly on LAN1
- Reconfigurable simultaneous movement

• **For Series LAN1:**

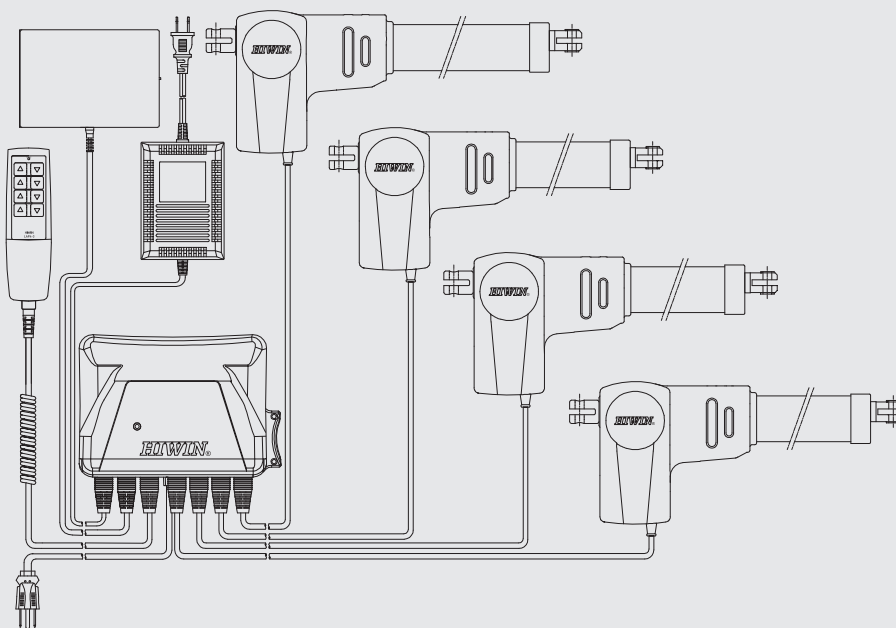

• **Ordering Information**

LAK4N - 1 - C000 - 110 - G E

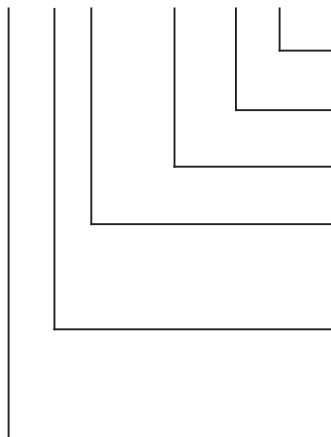

Special models according to Client's requirement	None E=Ignore this part of the serial number if not available
Color	B : Black G : Gray
Input Voltage	100 : AC100V ; 110 : AC110V 220 : AC220V ; 230 : AC230V
Actuator No.2 ~ No.4	0 : NO C : LAN1-1/-2 D : LAM3-3/-4 F : LAN1-1/-2/-3(24Q)
Actuator No.1	0 : NO C : LAN1-1/-2 D : LAM3-3/-4 F : LAN1-1/-2/-3(24Q)
External power	1 : 1.3Ah battery 2 : 2.9Ah battery 3 : 324VA Power adaptor 4 : 2.9Ah battery with 324VA power adaptor

* Check attached table for over current setting...see page 39.

10.

HIWIN 6-Axis Controller

LAK6B



Input voltage	AC 100/110/220/230V
Output power	216VA(24VDC)max
Duty cycle	10%
Working temp	+5°C ~40°C
Protection*	IP 54

* Option: (1) IP66
(2) Custom Program

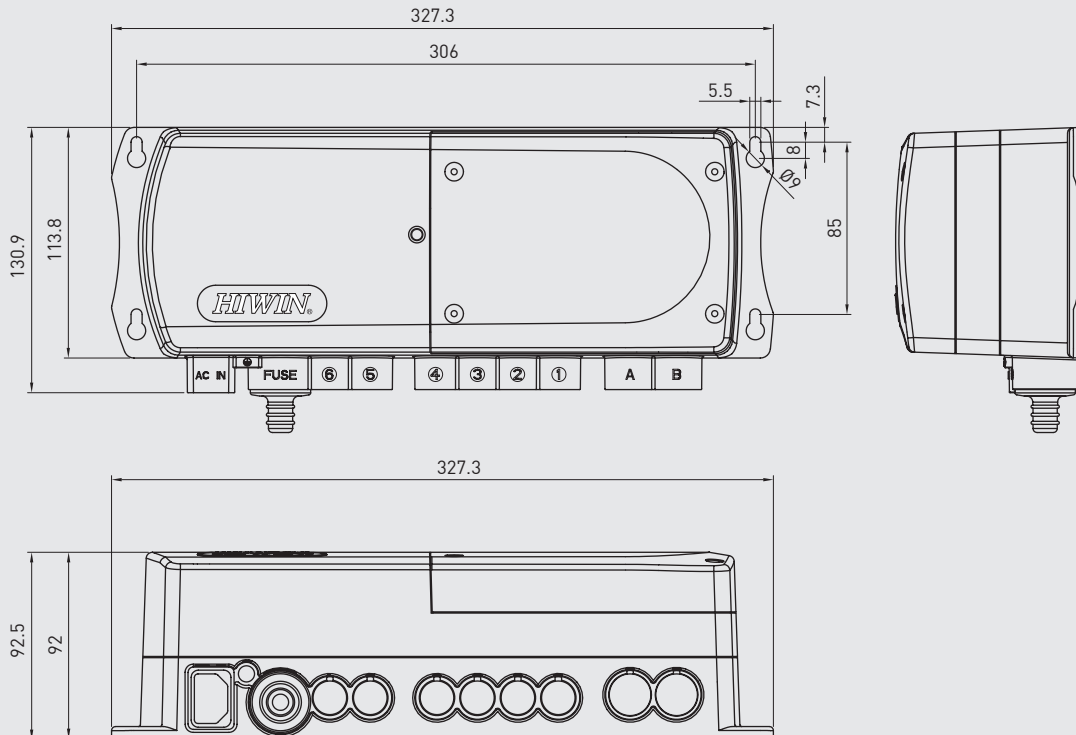

• Features of LAK6B

- Control 1 to 6 Linear Actuators
- Over current protection
- Soft-start
- Standard cable length: 4 M
- Rechargeable battery
- Low battery indicator (alarm)
- Automatic energy saving
- Battery capacity 1.3 Ah (12VDCx2)
- Main fuse replaceable by external plug
- Spare fuse inside the fuse plug
- External ground connection
- LED power indication

*Note: Please charge battery for at least 8 hours before initial use.

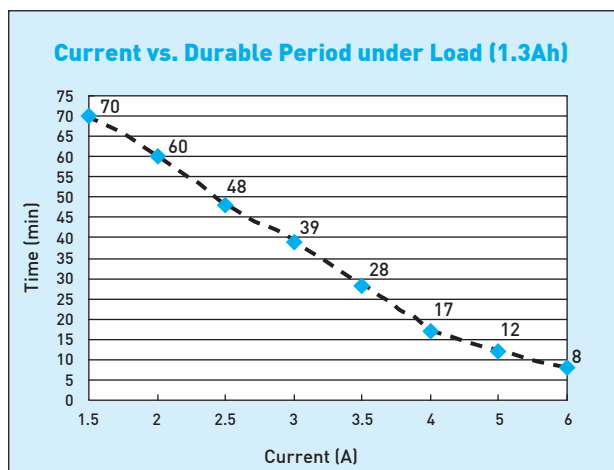

• For Series LAS4, LAM3, LAN1 and LAN3:

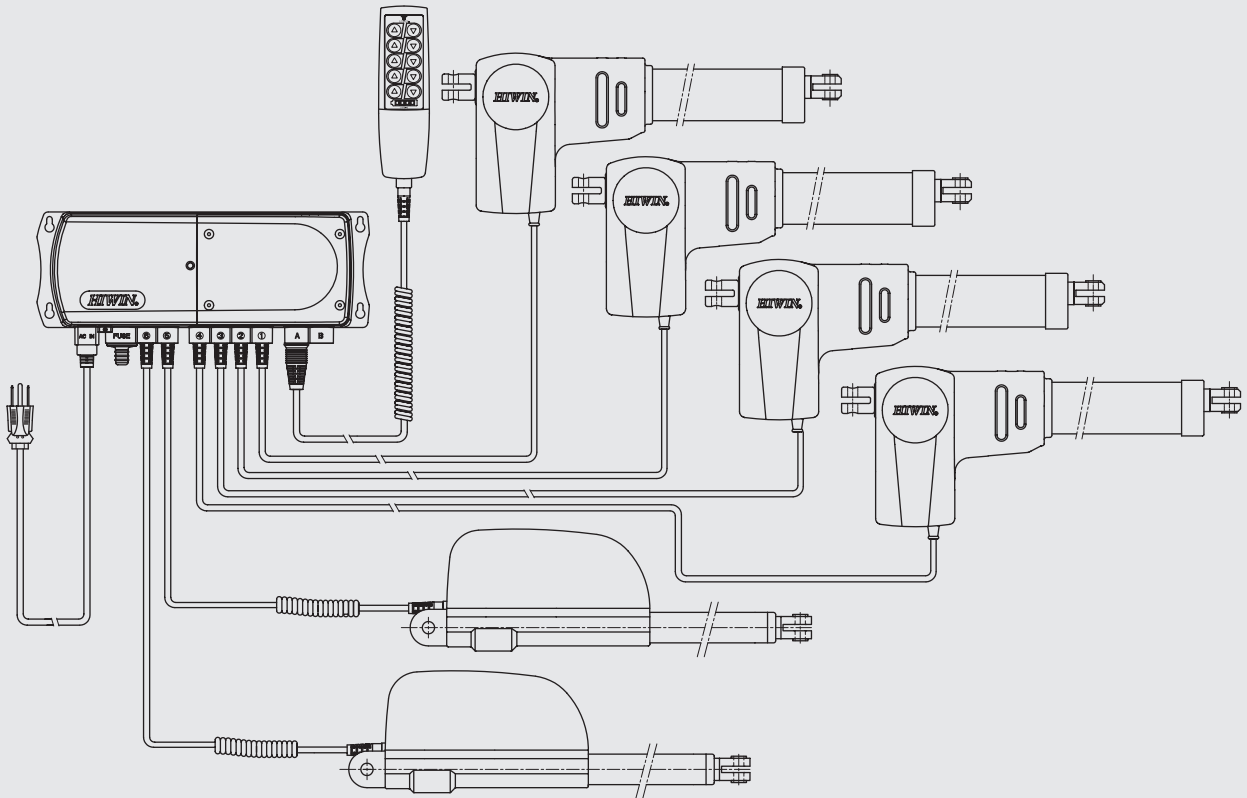

• Ordering Information

LAK6B - 1 - D 00000 - 110 - G E

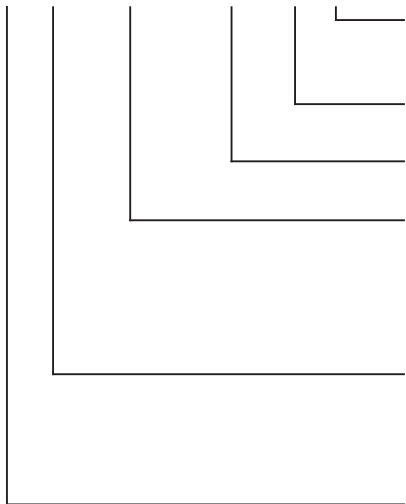

Special models according to Client's requirement	None E=Ignore this part of the serial number if not available
Color	B : Black G : Gray
Input Voltage	100 : AC100V ; 110 : AC110V 220 : AC220V ; 230 : AC230V
Actuator No. 2~No. 6	0 : NO A : LAS4-1 C : LAN1-1/-2 D : LAM3-3/-4 F : LAN1-1/-2/-3(24Q) ; LAM3-1 H : LAN3
Actuator No. 1	A : LAS4-1 C : LAN1-1/-2 D : LAM3-3/-4 F : LAN1-1/-2/-3(24Q) ; LAM3-1 H : LAN3
Battery	0 : No 1 : 1.3Ah

* Check attached table for over current setting...see page 39.

• **Over Current Setting Table**

Code No.	Current setting	Actuator Model	Controller Model
A	2.5A	LAS4-1	LAK2; LAK2B; LAK6B
B	3.0A	LAS-1; LAS3-1	LAK2; LAK2LR
C	4.0A	LAS-2; LAS3-2; LAS4-2; LAN1-1/-2/-3	LAK2; LAK2LR; LAK2D
D	5.0A	LAM3-3/-4	LAK2D; LAK4; LAK2B; LAK6B
E(24V)	6.0A	LAM3-2	LAK2D; LAK2B
E(12V)	6.0A	LAS-1(12V); LAS3-1(12V); LAS4-1(12V)	LAK2(DC)
F(24V)	7.0A	LAN1-1/-2/-3(24Q); LAM3-1	LAK2D; LAK2B; LAK6B; LAK4
F(12V)	7.0A	LAS-2(12V), LAS3-2(12V)	LAK2(DC)
G	8.0A	LAM-1/-2/-1A/-2A; LAN2	LAK2; LAK2LR
H	9.0A	LAN3	LAK6B
I	10A	For reservation	
J	12A	For reservation	
K	14A	For reservation	
L	15A	LAN1-1/-2/-3(12V); LAM-1/-2/-1A,-2A(12V)	LAK2(DC)
Z	**A	Special current value (special requirement)	

11.

HIWIN Over Current Protection Box

LAKC-1



Input voltage	12 / 24 VDC
Output voltage	12 / 24 VDC
Duty cycle	10%
Working temp	+5°C ~40°C
Protection*	IP 54

* Option: IP66

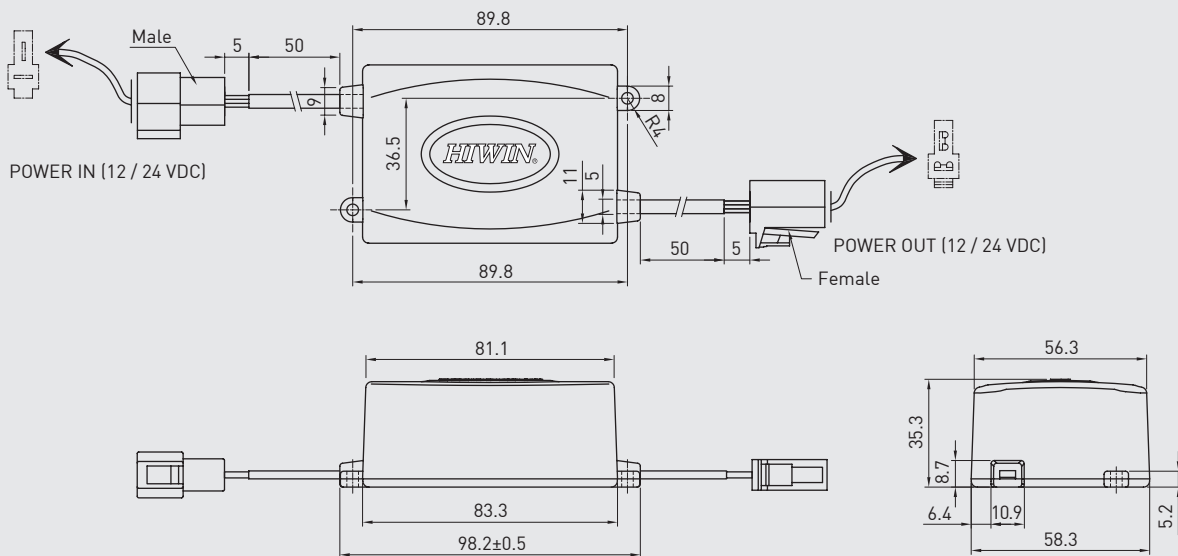

• Features of LAKC-1

- Compact size
- Low cost
- Easy to use
- Multiple over- current settings available
- Fast response time

• For Series LAS, LAS4, LAM, LAN1 and LAN4

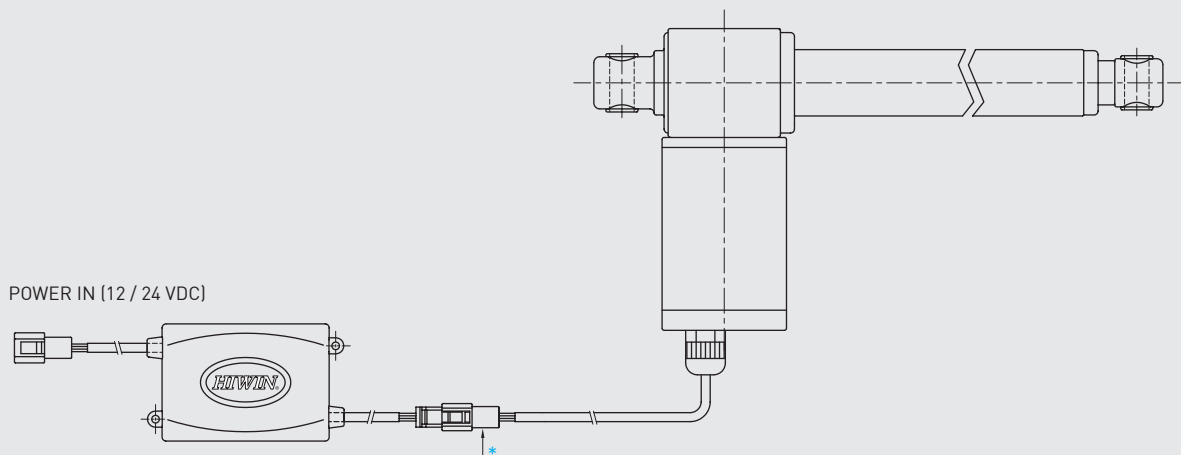

* When purchasing an actuator to be connected with LAKC, please mention to Hiwin sales personnel.

• Ordering Information

LAKC - 1 - 12 - 6 G E

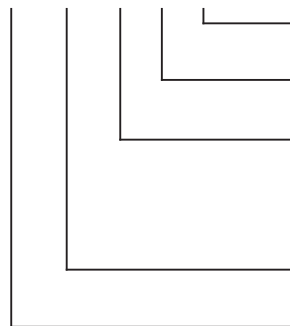

Special models according to Client's requirement	None E=Ignore this part of the serial number if not available
Color	B : Black G : Gray
Over Current Setting	2 : 2A 8 : 8A 3 : 3A 10 : 10A 4 : 4A 12 : 12A 5 : 5A 18 : 18A 6 : 6A
Input(Output)Voltage	12 : 12VDC 24 : 24VDC
Model number	

12.

HIWIN Keypad Series (1)

LAP1

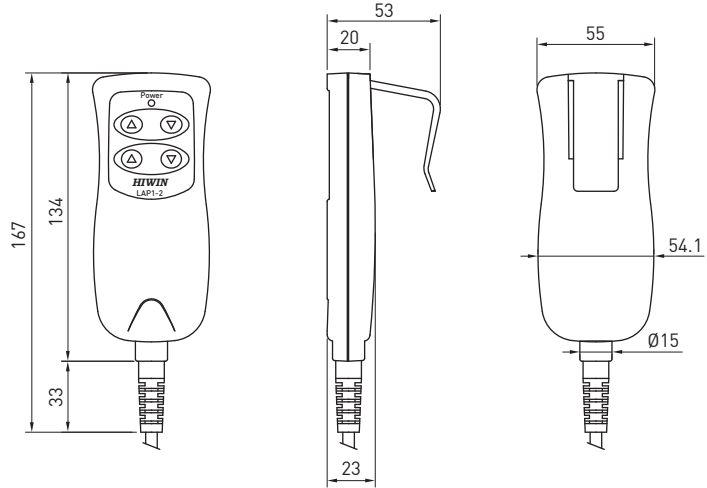

• Features of LAP1

- Control maximum of 2 Actuators
- Compatible with LAK2, LAK4, LAK2LR, LAK2D
- Ergonomic design
- Standard cable length: coil 600mm; total 1100mm
- Protection: IP66

LAP2

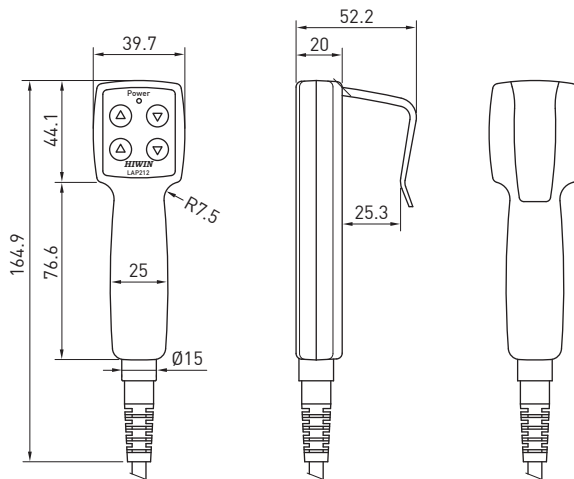

• Features of LAP2

- Control maximum of 2 Actuators
- Compatible with LAK2, LAK4, LAK2D
- Ergonomic design and small size
- Standard cable length: coil 600mm; total 1100mm
- Protection: IP66

LAP3

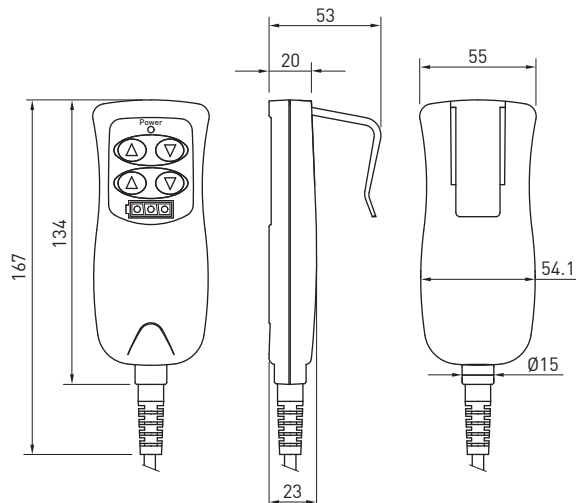

• Features of LAP3

- Control maximum of 2 Actuators
- Compatible with LAK2B
- Ergonomic design
- Standard cable length: coil 600mm; total 1100mm
- LED for battery capacity
- Protection: IP66

LAP4

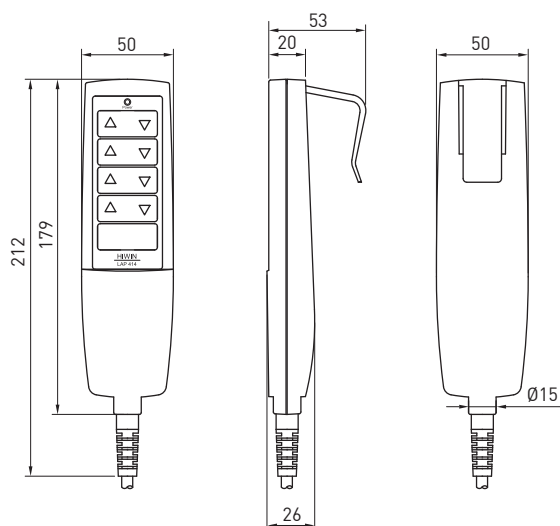

• Features of LAP4

- Control maximum of 4 Actuators
- Compatible with LAK4
- Ergonomic design
- Standard cable length: coil 600mm; total 2250mm
- Protection: IP66

13.

HIWIN Keypad Series (2)

LAP4M

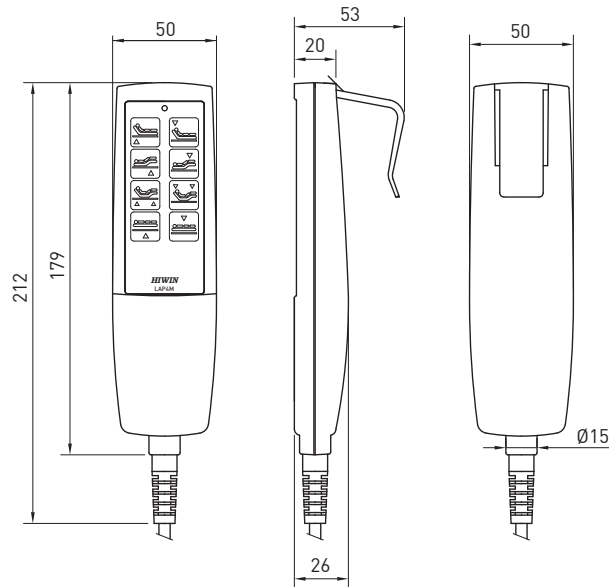

• Features of LAP4M

- Control maximum of 4 Actuators
- Compatible with LAK4
- Ergonomic design
- Standard cable length: coil 600mm; total 2250mm
- Protection: IP66

LAP5

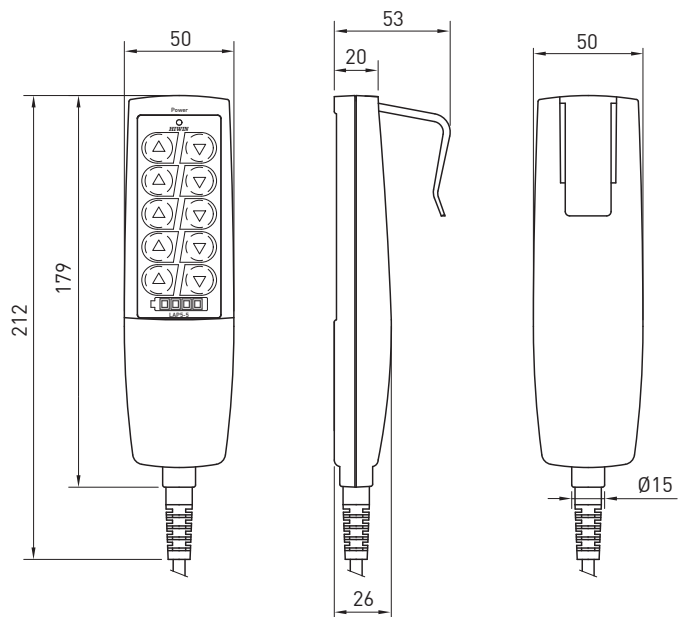

• Features of LAP5

- Control maximum of 5 Actuators
- Compatible with LAK6B, LAK2J
- Ergonomic design
- Standard cable length: coil 600mm; total 1100mm
- Protection: IP66

• Ordering Information

LAP1 - 2 - B E

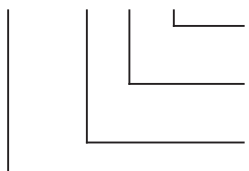

Special models according to Client's requirement	None E=Ignore this part of the serial number if not available
Color	B : Black G : Gray
Number of axis controlled	
Model number	LAP1 LAP4 LAP2 LAP4M LAP3 LAP5

LAFS

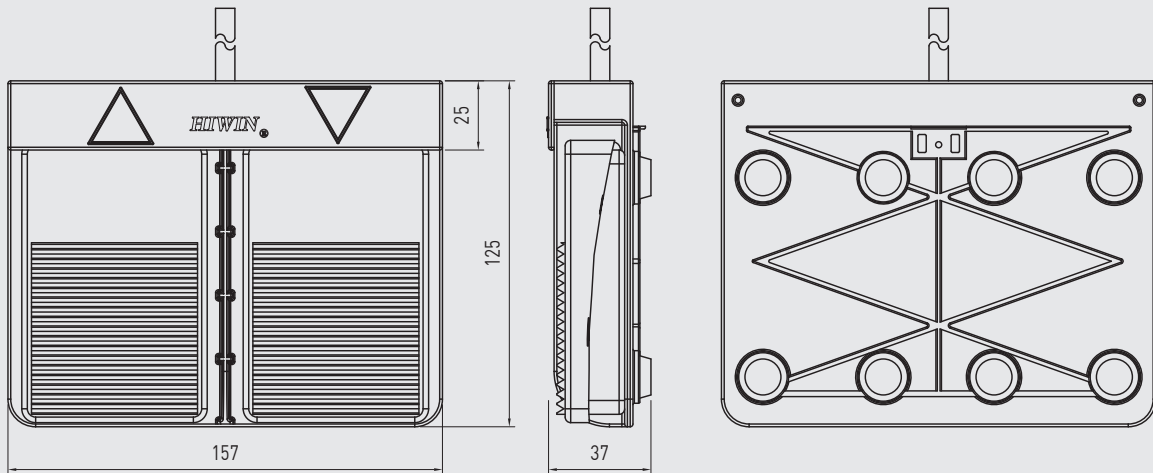

• Features of LAFS1

- Control 1 Actuator
- Compatible with all controllers
- Easily portable with attached magnet
- Standard cable length : coil 600mm;total 1100mm
- Protection : IP66

• Ordering Information

LAFS1 - 1 G E



Special models according to Client's requirement	None E=Ignore this part of the serial number if not available
Color	G : Gray
Number of axis controlled	
Model number	LAFS1

Y-CABLE

• Features of Y-Cable

- Compatible with 2 keypads input independently.

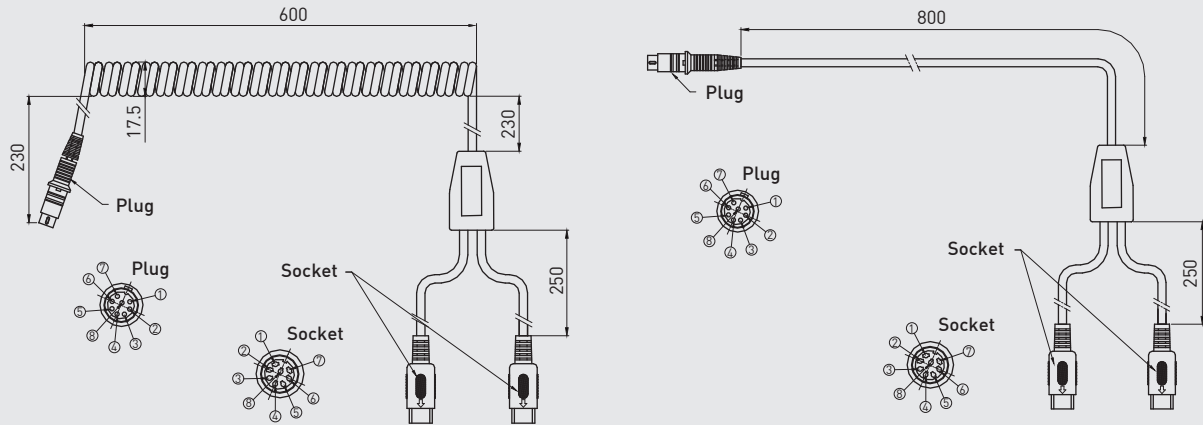

• Ordering Information

LAPY - 1 - G - E

Special models according to Client's requirement	None E=Ignore this part of the serial number if not available
Color	B : Black G : Gray
Cable	1. Coil cable 2. Straight cable
Model of Y extension cable	

14.

Options for Each Actuator Type

Series	Function	IP54	IP65	IP66	Back fixture turn 90°	Gear box material S45C	Rod end with flat connector	Safety nut	Spline (push only)	Quick release	Internal limit switches	External limit switches	Hall Sensor (NPN)	TTL	Potentiometer	Optical Sensor		
																NPN	PNP	TTL
LAM	LAM-1	●	▲		▲	▲						▲						
	LAM-2	●	▲		▲	▲						▲						
	LAM-1A	●	▲		▲	▲						▲						
	LAM-2A	●	▲		▲	▲						▲						
LAM3	LAM3-1	●		▲	▲			▲	▲		●							
	LAM3-2	●		▲	▲			▲	▲		●							
	LAM3-3	●		▲	▲			▲	▲		●							
	LAM3-4	●		▲	▲			▲	▲		●							
LAS	LAS1-1	●	▲		▲		▲				●							
	LAS1-2	●	▲		▲		▲				●							
LAS3	LAS3-1	●	▲								●		■		■	■	■	■
	LAS3-2	●	▲								●		■		■	■	■	■
LAS4	LAS4-1	●		▲							●							
	LAS4-2	●		▲							●							
LAN1	LAN1-1	●		▲	▲			▲	▲		●		▲	▲				
	LAN1-2	●		▲	▲			▲	▲		●		▲	▲				
	LAN1-3	●		▲	▲			▲	▲		●		▲	▲				
	LAN1-4	●		▲	▲			▲	▲	▲	●		▲	▲				
LAN2	LAN2-1A	●		▲				▲	◆			◆	▲					
	LAN2-2A	●		▲				▲	◆			◆	▲					
	LAN2-3A	●		▲				▲	◆			◆	▲					
LAN3	LAN3-1	●		▲	▲			▲	▲	▲	●				▲			
	LAN3-2	●		▲	▲			▲	▲	▲	●				▲			
	LAN3-3	●		▲	▲			▲	▲	▲	●				▲			
LAN4	LAN4-1	●		▲														
	LAN4-2	●		▲														
	LAN4-3	●		▲														
	LAN4-4	●		▲														

"●" Standard.

"▲" Option is available.

"◆" "■" Option is not available.

15.

HIWIN Customer Requirements(LA)

Customer:		Contact person:
		Tel:
		Fax:
Voltage VDC		Notes:
No-Load current		
Max. current		
Max. thrust force		
Max. pulling force		
Max. holding force		
Stroke		
Install length		
Speed (mm/s)		
Load (N)		
Duty cycle 10%		
Operation temp		
IP Class		
Outdoor use	<input type="checkbox"/> YES <input type="checkbox"/> NO	
Direction	<input type="checkbox"/> H <input type="checkbox"/> V	
Axial load	<input type="checkbox"/> YES <input type="checkbox"/> NO	
With L/S	<input type="checkbox"/> YES <input type="checkbox"/> NO	
With control	<input type="checkbox"/> YES <input type="checkbox"/> NO	
Over current	<input type="checkbox"/> YES <input type="checkbox"/> NO	
With customer's L/S		
Position capability		
Special design		
Expected price		
Quantity		
Recommended specification:		
Engineer:		

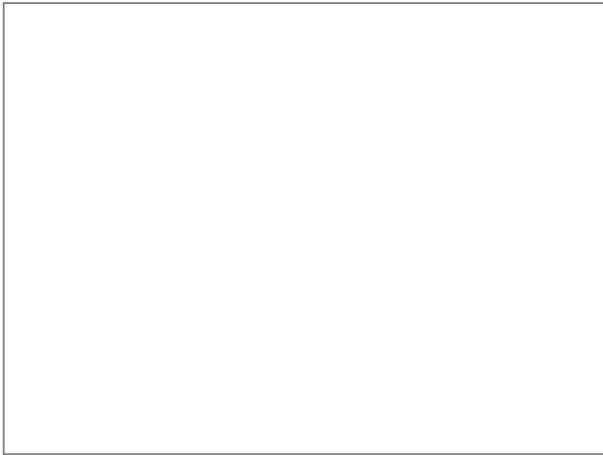

HIWIN MIKROSYSTEM CORP.

No. 1, 6th Road
Taichung Industrial Park
Taichung 40755, TAIWAN
Tel : +886-4-23550110
Fax: +886-4-23550123
www.hiwinmikro.com.tw
business@mail.hiwinmikro.com.tw

HIWIN JAPAN

•KOBE
3F, Sannomiya-Chuo Bldg.
4-2-20 Goko-Dori, Chuo-Ku
KOBE 651-0087, JAPAN
Tel: +81-78-2625413
Fax: +81-78-2625686
www.hiwin.co.jp
info@hiwin.co.jp

HIWIN GmbH

Brücklesbünd 2, D-77654
Offenburg, GERMANY
Tel: +49-781-93278-0
Fax: +49-781-93278-90
www.hiwin.de
info@hiwin.de

HIWIN SCHWEIZ

Einsiedlerstrasse 535
8810 Horgen, SWITZERLAND
Tel: +41-43-3550330
Fax: +41-43-3550331
www.hiwin.ch
info@hiwin.ch

HIWIN S.R.O.

Kastanova 34
CZ 62000 Brno,
CZECH REPUBLIC
Tel: +420-548-528238
Fax: +420-548-220233
www.hiwin.cz
info@hiwin.cz

HIWIN USA

•CHICAGO
1400 Madeline Lane
Elgin, IL. 60124, U.S.A.
Tel: +1-847-8272270
Fax: +1-847-8272291
www.hiwin.com
info@hiwin.com

•SILICON VALLEY

Tel: +1-510-4380871
Fax: +1-510-4380873