

Spindle specification	3-5
Spindle selection	6
TSA - External taper style	7
TSI - Internal taper style	8
TSP - Cylindric pilot with face clamping	9
TSAV - Heavy duty style with external taper	10-11
TSEV - Direct motorized surface grinder style	12-13
Technical characteristics of TSEV-style	14
Sealing options TSA-, TSI-, TSP- and TSAV/TSEV-style	15
Cutting speed	16
TSA - Grinding wheel flanges	17
TSAV/TSEV - Grinding wheel flanges	18-19
Anti-rotation option TSAV/TSEV-style	20
Taper specifications TSA-, TSI-, and TSAV/TSEV-style	21
Tooling accessories TSA - Collet chuck, TSA - Grinding quill	22
Tooling accessories TSI - Collet chuck, TSP - Clamping chuck	23
Grinding quills TSI-, TSP-style	24-25
TSI/TSP - Grinding quill selection data	26
Pulleys TSA-, TSI-, TSP- and TSAV-style	27
TSAV - Balancing system	28
TSEV - Balancing system	29
Balancing system Automatic balancing system	30
Balancing system Portable balancing system	31
Stiffness - Load capacity TSA-, TSI/TSP-, TSAV- and TSEV-style	32-34
General safety rules	35-36
Radial and axial runout	37
GMN - Representations	38

GMN precision spindles belt driven and direct motorized have been accepted world wide as the standard for precision on internal and universal grinders. Their reliability is derived from over seven decades of experience in design, use and manufacture of precision rotating mechanisms.

GMN has a wide range of models to choose from with either manual or automatic tool change systems and a speed up to 180 000 rpm.

We can offer solutions to meet the most difficult applications.

Our preferred styles offer prompt delivery and attractive pricing.

GMN is the trademark of Paul Müller Industrie GmbH & Co. KG.

This catalog reflects the latest design features at the time of printing. The company reserves the right to change designs and specifications at any time.

Reprint, photomechanical reproductions as well as reproduction from clippings only with license of Paul Müller Industrie GmbH & Co. KG.



TSA, TSA..c

external taper, belt driven

- duplex pair of GMN precision bearing
- TSA..c with [hybrid ceramic bearings](#)
- permanently grease lubricated
- spring preloaded design

applications

- high speed grinding
- wide speed range
- small, medium and large bores

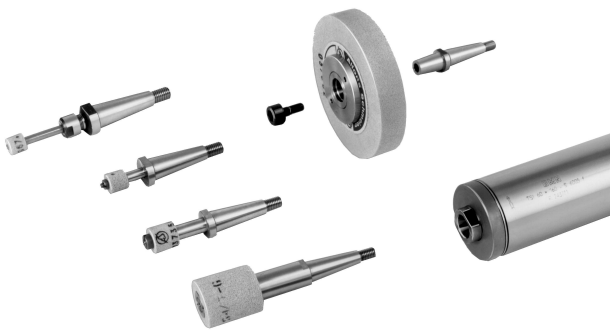

TSI, TSI..c

internal taper, belt driven

- duplex pair of GMN precision bearing
- TSI..c with [hybrid ceramic bearings](#)
- permanently grease lubricated
- spring preloaded design

applications

- high speed grinding
- wide speed range
- small, medium and large bores

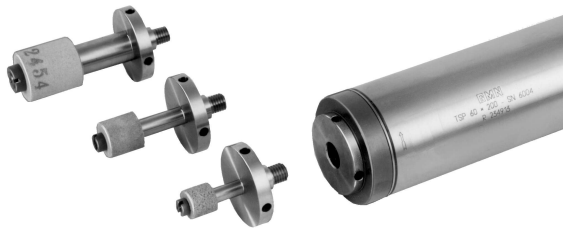

TSP, TSP..c

internal cylindrical pilot with draw thread and face clamping, belt driven

- duplex pair of GMN precision bearing
- TSP..c with [hybrid ceramic bearings](#)
- permanently grease lubricated
- spring preloaded design

applications

- high speed grinding
- wide speed range
- small, medium and large bores



TSAV

external taper, belt driven

- quad set of precision bearings at nose end
- solid preload design
- permanently grease lubricated

applications

- large deep bores
- for high loads
- for high stiffness requirements



TSL

external taper and stepped spindle housing, for deep internal bore grinding, belt driven

- quad set of precision bearings at nose end solid preload design
- permanently grease lubricated applications
- medium and large, deep bores

Further information on request.



TSE, TSE..c

with air cooled motor

- tool interface: integrated collet nose, HSK or according to customer's requirements

- precision bearings
- permanent oil/air or grease lubrication
- TSE..c with hybrid ceramic bearings
- clamping on cylindrical housing
- frequency inverter compatible
- for low power requirements
- for light machining operations
- for high speed grinding

Further information on request.

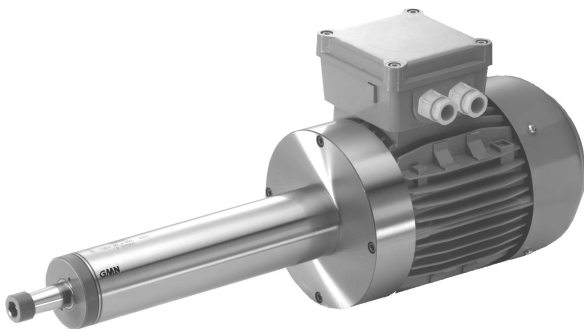

TSEV

with air cooled motor

- external style grinding taper
- precision bearings, solid preloaded
- permanent grease lubrication
- clamping on cylindrical housing
- frequency converter compatible or direct AC voltage
- economical support equipment
- for heavy machining operations
- for high requirement stiffness

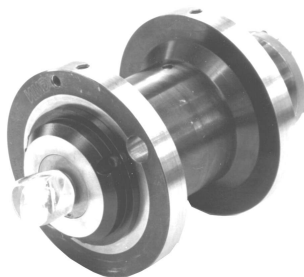

TS, HLS

Opto spindles with ball bearings, static or dynamic air bearings

- scan accuracy $\Delta t / t = 10^{-5} \dots 10^{-6}$ up to 100000 rpm

Please ask for catalog # 2502.

Spindle Specification

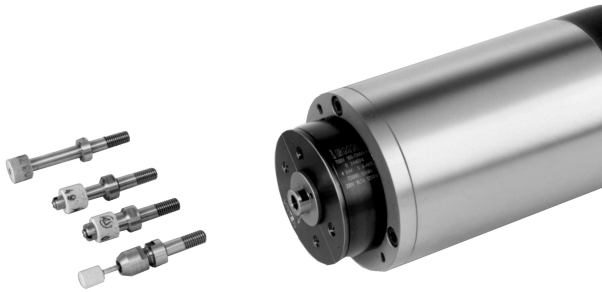

TSSV, HS, HSX

High frequency spindle with integral asynchronous motor, liquid cooled front bearings and stator

- ultra precision ball bearings
- HSX standard with [hybrid ceramic bearings](#)
- oil/air lubricated
- for manual tool change via pilot with draw thread and clamping face

Please ask for catalog # 2508.



HSP

High frequency spindle with integral asynchronous motor, liquid cooled front bearings and stator

- ultra precision ball bearings
- [hybrid ceramic bearings](#)
- oil/air or permanently grease lubricated
- for manual tool change via HSK interface

Please ask for catalog # 2508.



HCS

High frequency spindle for automatic tool change and asynchronous motor for closed-loop drive (vectordrive)

- liquid cooled front bearings and stator
- ball bearings of ultra precision quality
- [hybrid ceramic bearings](#)
- oil/air or permanently grease lubricated
- ISO taper or HSK tool interface
- airblast for tool connection cleaning

Please ask for catalog # 2505.

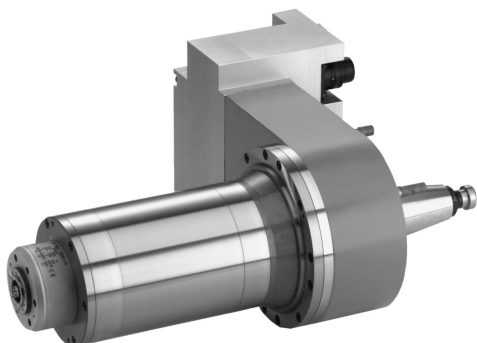

Special spindles per customer's requirements.

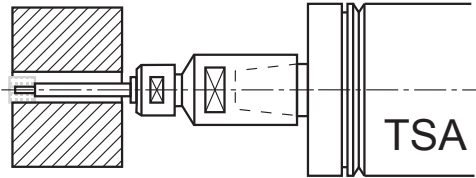

Fig. 1

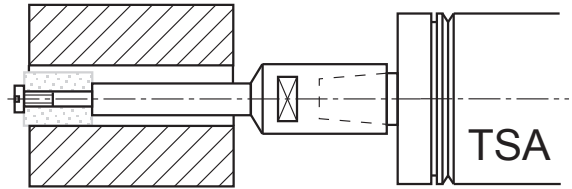
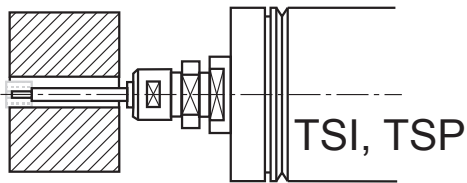

Fig. 2



For grinding bores **smaller** than the outside diameter of the chosen spindle style, the TSI or TSP spindle is recommended, because the wheel will be mounted closer to the bearing complement for better rigidity.

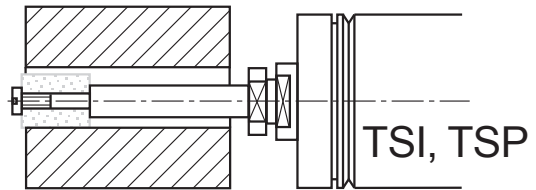

Fig. 4

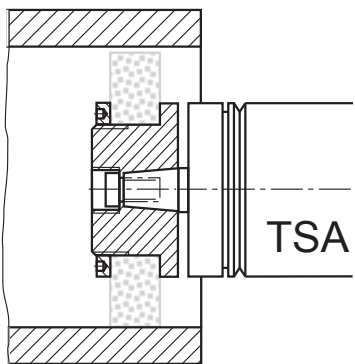
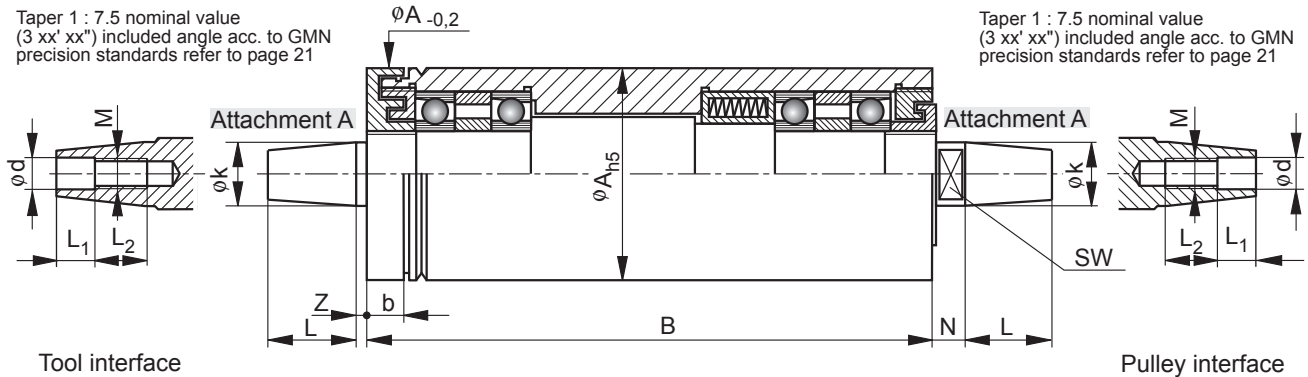

Fig. 3

For grinding bores **larger** than the outside diameter of the chosen spindle style, the TSA spindle is recommended, because the wheel will be mounted closer to the bearing complement for better rigidity.



For external and surface grinding the TSAV spindle is recommended, because the quad bearing arrangement, and external taper provide higher rigidity, and the uses of larger diameter wheels.



Spindle Style ¹⁾	Attachment						Z	b	N	SW	Max. Speed ²⁾ for bearing types [rpm]	
	k	L	d	M	L ₁	L ₂					Steel	Hybrid
TSA 20 x 125	A 07						2	5	7	6	80000	+
TSA 20 x 160	A 07										60000	+
TSA 20 x 200 TSA 20 x 250	7,5	10	4	M 4	5	7					60000	+
TSA 26 x 125	A 08						2	6,5	7	7	60000	+
TSA 26 x 160	A 08										40000	+
TSA 26 x 200 TSA 26 x 250	8	11,25	4	M 4	5	7					30000	+
TSA 26 x 315	A 10						2,5	6	8	8	60000	+
TSA 32 x 125	A 10										40000	+
TSA 32 x 160	A 10										30000	+
TSA 32 x 200 TSA 32 x 250	10	15	5	M 5	7	8	40000	+				
TSA 32 x 315 TSA 32 x 355	A 10						2,5	9,5	7	8	45000	55000
TSA 40 x 160	A 10										35000	42000
TSA 40 x 200 TSA 40 x 250	10	15	5	M 5	7	8					30000	35000
TSA 50 x 160	A 13						3	10,5	8	11	35000	42000
TSA 50 x 200	A 13										30000	35000
TSA 50 x 250	A 13										20000	25000
TSA 50 x 315	13,5	20	6	M 6	8	12	20000	25000				
TSA 60 x 160	A 18						3	10,5	9	15	30000	35000
TSA 60 x 200	A 18										20000	25000
TSA 60 x 250	A 18										15000	20000
TSA 60 x 315	18	25	8	M 8	11	14	15000	20000				
TSA 80 x 200	A 27						4	14,5	12	24	20000	25000
TSA 80 x 250	A 27										15000	20000
TSA 80 x 315	A 27										10000	15000
TSA 80 x 355	27,67	35	12	M 12	13	21	10000	15000				
TSA 100 x 250	A 38						4	16	15	32	15000	20000
TSA 100 x 315	A 38										10000	15000
TSA 100 x 355	A 38										5000	10000
TSA 100 x 355	38	52,5	16	M 16	25	25	5000	10000				

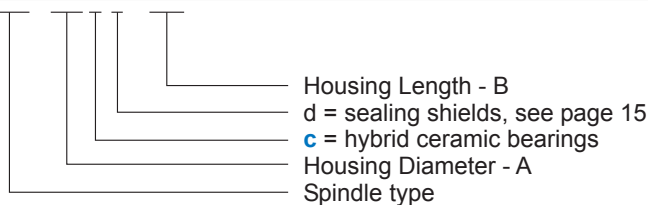

1) Preference types are in bold.
2) Without tool.

Depending on tool design and weight the maximum operating speed may be reduced.

+ ... Ceramic balls on request.

Please state direction of rotation, see page 35, for information.

1 mm = 0.03937 in.

Taper 1 : 7.5 nominal value
(3 xx' xx") included angle acc. to GMN
precision standards refer to page 21

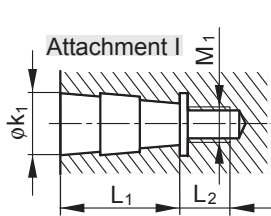

Tool interface

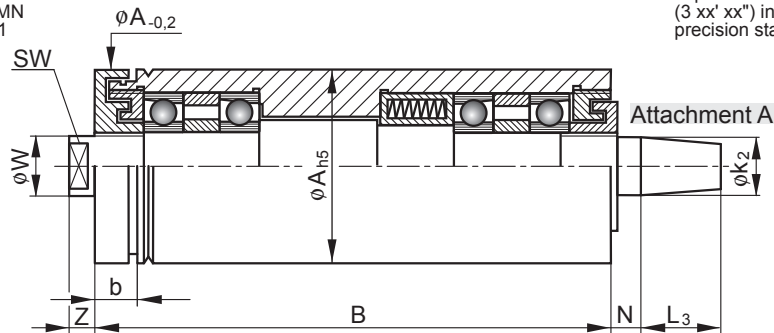

Taper 1 : 7.5 nominal value
(3 xx' xx") included angle acc. to GMN
precision standards refer to page 21

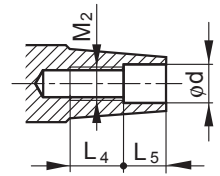

Pulley interface

Spindle Style ¹⁾	Attachment				W	Z	SW	b	N	Attachment						Max. speed ²⁾ for bearing types [rpm]	
	k ₁	L ₁	L ₂	M ₁						k ₂	L ₃	d	M ₂	L ₄	L ₅	Steel	Hybrid
TSI 40 ■ x 160	I 10				19	6	17	9,5	6	A 10						45000	55000
TSI 40 ■ x 200	10	26	16	M 6						10	15	5	M 5	8	7		
TSI 40 ■ x 250																	
TSI 50 ■ x 160	I 14				22	6	19	10,5	7	A 13						35000	42000
TSI 50 ■ x 200	14	35	17	M 8						13,5	20	6	M 6	12	8		
TSI 50 ■ x 250																	
TSI 60 ■ x 160	I 18				27	8	24	10,5	7	A 18						30000	35000
TSI 60 ■ x 200																	
TSI 60 ■ x 250																	
TSI 60 ■ x 315	18	45	19	M 10						18	25	8	M 8	14	11		
TSI 60 ■ x 355																	
TSI 80 ■ x 200	I 25				33,7	11	30	14,5	8	A 27						20000	25000
TSI 80 ■ x 250																	
TSI 80 ■ x 315	25	63	25	M 12						27,67	35	12	M 12	21	13		
TSI 80 ■ x 355																	
TSI 100 ■ x 250	I 32				43,7	13	41	16	12	A 38						15000	20000
TSI 100 ■ x 315																	
TSI 100 ■ x 355	32	80	34	M 20						38	52,5	16	M 16	25	25		

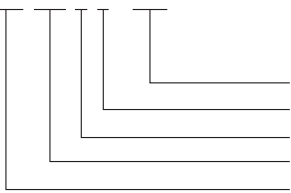

Housing Length - B
d = sealing shields, see page 15
c = hybrid ceramic bearings
Housing Diameter - A
Spindle type

- 1) Preference types are in bold.
- 2) Without tool.

Depending on tool design and weight the maximum operating speed may be reduced .

Please state direction of rotation, see page 35, for information.

1 mm = 0.03937 in.

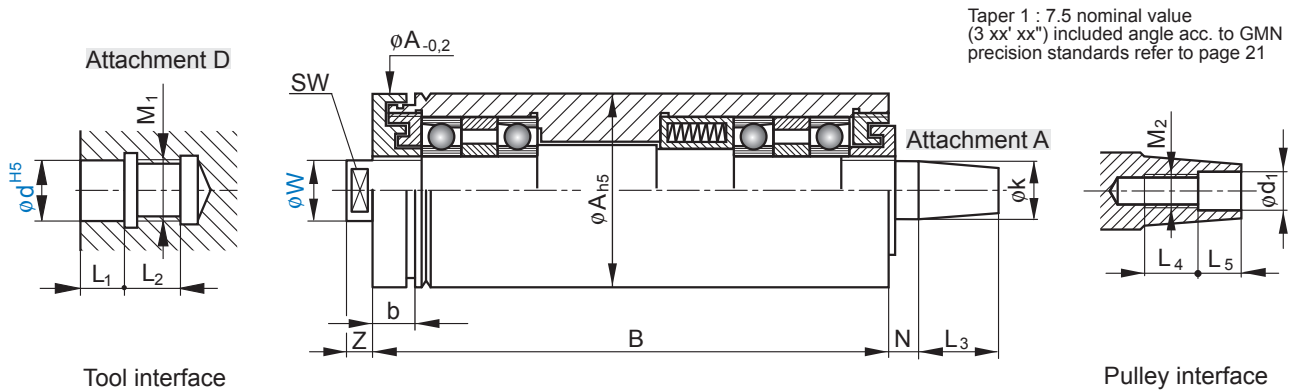

Spindle Style ¹⁾	Attachment D [d] / [W]	L ₁	L ₂	M ₁	b	Z	SW	N	Attachment						Max. speed ²⁾ for bearing types [rpm]	
									k	L ₃	d ₁	M ₂	L ₄	L ₅	Steel	Hybrid
TSP 40 ■ ■ x 160 TSP 40 ■ ■ x 200 TSP 40 ■ ■ x 250	D 08/14	12	14	M 8	9,5	6	13	6	A 10						45000	55000
TSP 50 ■ ■ x 160 TSP 50 ■ ■ x 200 TSP 50 ■ ■ x 250	D 10/18	15	19	M 10	10,5	8	15	7	13,5	20	6	M 6	12	8	35000	42000
TSP 60 ■ ■ x 160 TSP 60 ■ ■ x 200 TSP 60 ■ ■ x 250 TSP 60 ■ ■ x 315 TSP 60 ■ ■ x 355	D 14/23	20	19	M 14 x 1,5	10,7	10	19	7	18	25	8	M 8	14	11	30000	35000
TSP 80 ■ ■ x 200 TSP 80 ■ ■ x 250 TSP 80 ■ ■ x 315 TSP 80 ■ ■ x 355	D 16/33	24	19	M 16 x 1,5	14,5	11	27	8	27,67	35	12	M 12	21	13	20000	25000
TSP 100 ■ ■ x 250 TSP 100 ■ ■ x 315 TSP 100 ■ ■ x 355	D 28/43	42	25	M 28 x 2	16	13	36	12	38	52,5	16	M 16	25	25	15000	20000

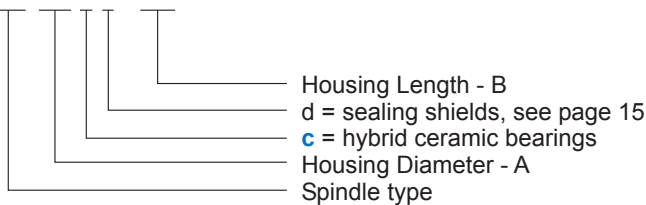

Please state direction of rotation, see page 35, for information.

- 1) **Preference types** are in bold.
2) Without tool.

Depending on tool design and weight the maximum operating speed may be reduced.

1 mm = 0.03937 in.

Taper 1 : 7.5 nominal value
(3 xx' xx") included angle acc. to GMN
precision standards refer to page 21

Taper 1 : 7.5 nominal value
(3 xx' xx") included angle acc. to GMN
precision standards refer to page 21

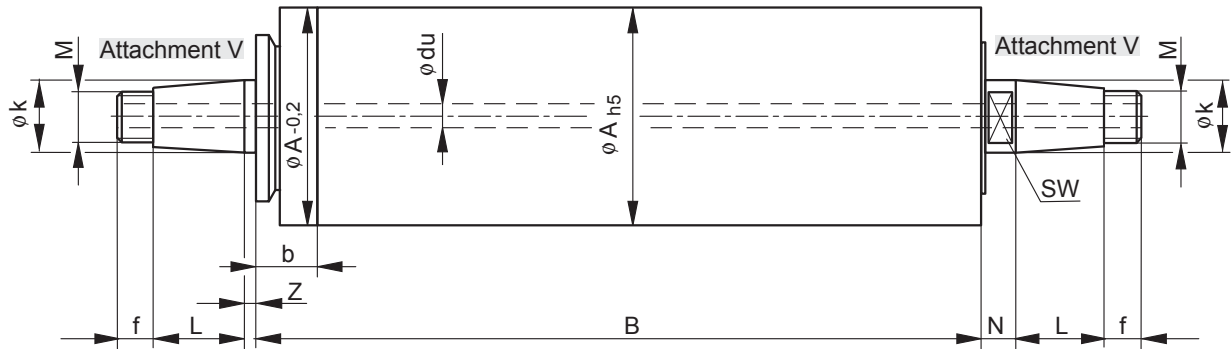

Tool interface

Pulley interface

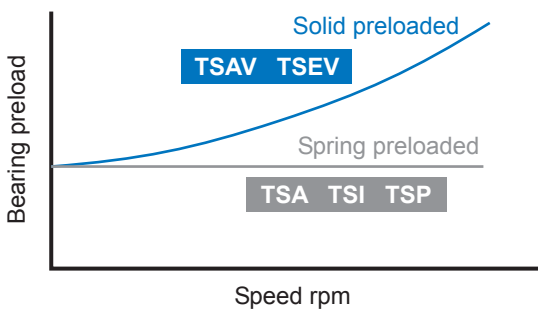
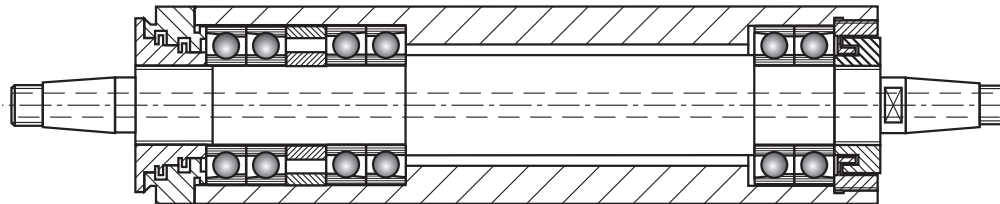

This arrangement limits the spindle speed in comparison to the same bearing bore sizes used in the TSA, TSI, TSP and TSE styles. Another advantage is low axial shaft movement, which is required for face grinding.

Higher speeds are available, but with **reduced preload**.

Hollow shafts are an option for allowing **low pressure coolant through** to the work piece.

TSAV designs with **High Pressure Rotary Coolant Unions** are available, starting at 100 mm body diameter.

TSAV and TSEV spindle styles have a solid bearing arrangement as opposed to the other belt driven designs which are spring preloaded. The solid bearing mounting provides for higher spindle stiffness and load carrying capacity at maximum spindle speed.

Spindle Style ¹⁾	Attachment			Dimensions [mm]						Max. Speed ²⁾ [rpm]	
	k	L	M	f	Z	b	N	SW	du ³⁾	Execution	Modification
TSAV 40 x 160	12,83	15	M 10 x 1	7	2,5	9,5	7	10	6	13000	32000
TSAV 40 x 200											
TSAV 40 x 250											
TSAV 40 x 315											
TSAV 40 x 355											
TSAV 40 x 355	15,5	20	M 12 x 1	7	3	11,5	8	13	8	10500	26000
TSAV 50 x 200											
TSAV 50 x 250											
TSAV 50 x 315											
TSAV 50 x 400											
TSAV 50 x 400	20	25	M 16 x 1	10	3	10,5	9	17	10	8500	20000
TSAV 60 x 200											
TSAV 60 x 250											
TSAV 60 x 315											
TSAV 60 x 355											
TSAV 60 x 400	27,67	35	M 20 x 1	12	4	14	12	24	14	6500	15000
TSAV 60 x 500											
TSAV 60 x 630											
TSAV 80 x 250											
TSAV 80 x 315											
TSAV 80 x 355	38	52,5	M 30 x 1	12,5	4	17	15	32	20	5500	11000
TSAV 80 x 400											
TSAV 80 x 500											
TSAV 80 x 630											
TSAV 80 x 800											
TSAV 100 x 315	52	65	M 36 x 1	17,5	5	28	18	46	25	4500	7000
TSAV 100 x 355											
TSAV 100 x 400											
TSAV 100 x 500											
TSAV 100 x 630											
TSAV 100 x 800	56	75	M 40 x 1,5	17,5	5	32,5	18	48	30	3500	6000
TSAV 120 x 355											
TSAV 120 x 400											
TSAV 120 x 500											
TSAV 120 x 630											
TSAV 120 x 800	87	110	M 65 x 1,5	20	6	33,5	21	60	35	2500	5000
TSAV 120 x 1000											
TSAV 140 x 400											
TSAV 140 x 500											
TSAV 140 x 630											
TSAV 140 x 800	87	110	M 65 x 1,5	20	6	35	24	75	40	1500	3000
TSAV 140 x 1000											
TSAV 160 x 400											
TSAV 160 x 500											
TSAV 160 x 630											
TSAV 200 x 400	87	110	M 65 x 1,5	20	6	35	24	75	40	1500	2000
TSAV 200 x 500											
TSAV 200 x 630											

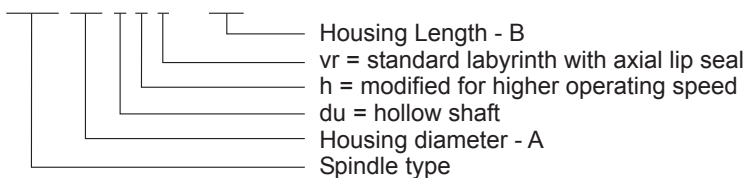

- 1) **Preference types** are in bold.
- 2) Without tool.
Depending on tool design and weight the maximum operating speed may be reduced.
- 3) Option: du

Max. speed for vr, see chart on page 15.
Option "anti-rotation" for dual rotation
see page 20.

Please state direction of rotation,
see page 35, for information.

1 mm = 0.03937 in.

Taper 1 : 7.5 nominal value
(3 xx' xx") included angle acc. to GMN
precision standards refer to page 21

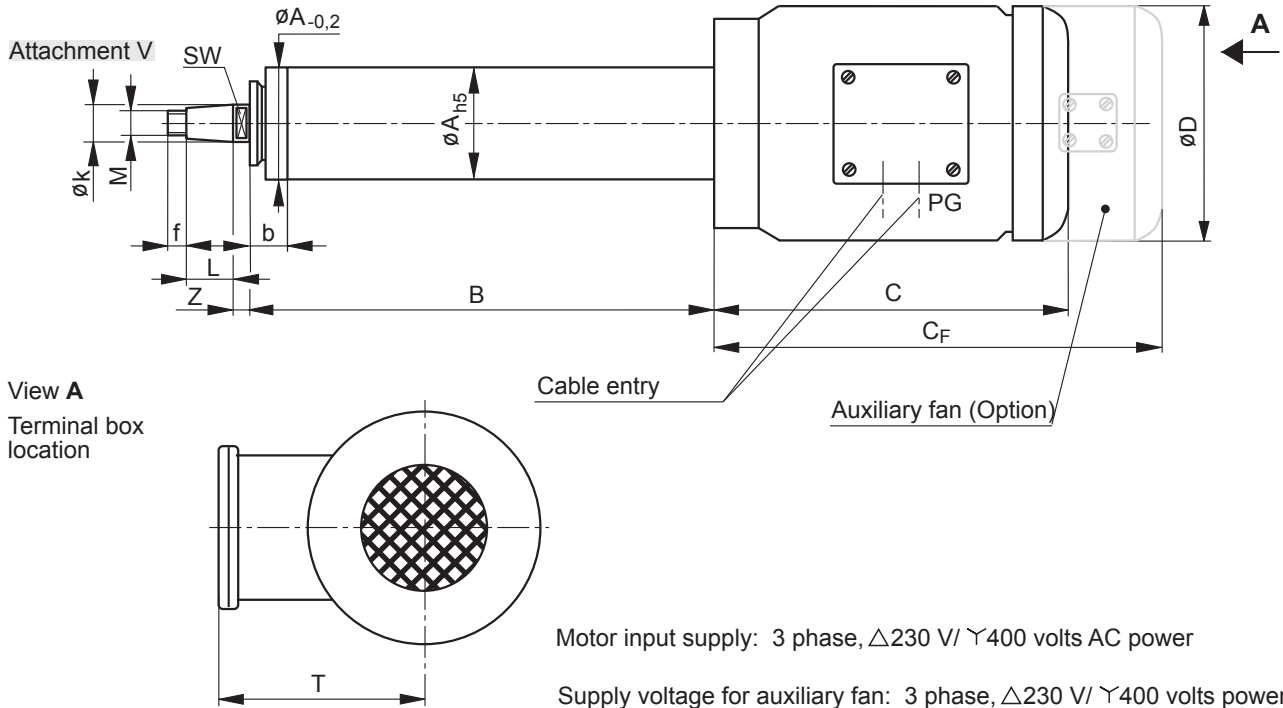

Motor input supply: 3 phase, Δ 230 V/ Υ 400 volts AC power

Supply voltage for auxiliary fan: 3 phase, Δ 230 V/ Υ 400 volts power

TSEV-spindles are equipped with air cooled asynchronous motors. The speeds shown in the chart below are the available ranges, and are calculated per the following formula:

$$n = \frac{120 \times f}{p}$$

N = Speed
 f = Frequency
 p = Number of poles

Specified speed

Number of poles	2	4	6
Frequenz			
bei 50 Hz	3000	1500	1000
bei 60 Hz	3600	1800	1200
bei 100 Hz	6000	3000	2000
bei 200 Hz	12000	6000	4000

The motors are designed to operate up to 200 hertz. Special motors are required for speeds, which exceed those specified in the chart.

Frequency converters allow the spindles to be operated over a variable speed range. When selecting a converter special attention should be paid to the smoothness of the sine wave, which is critical to the performance of the spindle.

Erratic sine wave peaks can cause the motor to run hot, which causes a loss of output power, and also increases the electromagnetic interference.

The cooling fan is attached to the rear of the spindle shaft, and operates at the specified speed of the spindle. The cooling is sufficient for the output power of the motor, and noise levels are minimal. Increasing the spindle speed above the specified range can increase the decibel level to UN-acceptable, and also cause damage to the fan and spindle. Speeds above 100 hertz require an auxiliary fan motor.

Additional features:

- PTC resistors and thermistors are imbedded in the motor windings for temperature monitoring
- Motor housings are painted RAL 7032 Grey, as a standard
- Power cables can be supplied, please refer to page 14
- Spindles with increased output power can be supplied, but will require liquid cooled motors

Spindle Style ¹⁾	Attachment			Dimensions [mm]								PG	Power ²⁾ [kW]	Max. Speed ³⁾ [rpm]	
	k	L	M	f	Z	b	SW	D	C	C _F	T			n _B ⁴⁾	n _{max} ⁵⁾
TSEV 50 x 200 - 071/2	V 15			7	8	11,5	13	138	222	326	127	11	0,55	4800	10500 24000
TSEV 50 x 250 - 071/2	15,5	20	M 12 x 1												
TSEV 50 x 315 - 071/2															
TSEV 60 x 200 - 080/2	V 20			10	9	11,5	17	156	238,5	343,5	138,5	16	1,1	4800	8500 20000
TSEV 60 x 250 - 080/2	20	25	M 16 x 1												
TSEV 60 x 315 - 080/2															
TSEV 60 x 355 - 080/2															
TSEV 80 x 250 - 090/2	V 27			12	12	14,5	24	176	282,5	386,5	151	16	2,2	4800	6500 15000
TSEV 80 x 315 - 090/2	27,67	35	M 20 x 1												
TSEV 80 x 355 - 090/2															
TSEV 80 x 400 - 090/2															6500 12000
TSEV 80 x 500 - 090/2															
TSEV 100 x 315 - 112/2	V 38			12,5	15	17,5	32	218	312,5	406,5	169,5	16	4	4800	5500 10000
TSEV 100 x 355 - 112/2	38	52,5	M 30 x 1												
TSEV 100 x 400 - 112/2															
TSEV 100 x 500 - 112/2															
TSEV 100 x 630 - 112/2															
TSEV 100 x 315 - 112/4	V 38			12,5	15	17,5	32	218	312,5	406,5	169,5	16	4	2400	5500 6000
TSEV 100 x 355 - 112/4	38	52,5	M 30 x 1												
TSEV 100 x 400 - 112/4															
TSEV 100 x 500 - 112/4															
TSEV 100 x 630 - 112/4															
TSEV 120 x 355 - 132/2	V 52			17,5	18	28	46	258	397	528	189,5	16	7,5	4800	4800 6000
TSEV 120 x 400 - 132/2	52	65	M 36 x 1												
TSEV 120 x 500 - 132/2															
TSEV 120 x 800 - 132/2															
TSEV 120 x 1000 - 132/2															
TSEV 120 x 355 - 132/4	V 52			17,5	18	28	46	258	397	528	189,5	16	7,5	2400	4500 6000
TSEV 120 x 400 - 132/4	52	65	M 36 x 1												
TSEV 120 x 500 - 132/4															
TSEV 120 x 800 - 132/4															
TSEV 120 x 1000 - 132/4															
TSEV 140 x 400 - 132/2	V 56			17,5	18	32,5	48	258	402	518	189,5	16	7,5	3500	3500 4000
TSEV 140 x 500 - 132/2	56	75	M 40 x 1,5												
TSEV 140 x 630 - 132/2															
TSEV 140 x 800 - 132/2															
TSEV 140 x 1000 - 132/2															
TSEV 140 x 400 - 132/4	V 56			17,5	18	32,5	48	258	409	539	189,5	16	7,5	2400	3500 6000
TSEV 140 x 500 - 132/4	56	75	M 40 x 1,5												
TSEV 140 x 630 - 132/4															
TSEV 140 x 800 - 132/4															
TSEV 140 x 1000 - 132/4															
TSEV 160 x 400 - 160/4	V 87			20	21	33,5	60	310	521	672	225	21	11	2400	2500 4500
TSEV 160 x 500 - 160/4	87	110	M 65 x 1,5												
TSEV 160 x 400 - 160/6															
TSEV 160 x 500 - 160/6	87	110	M 65 x 1,5												2500 3000

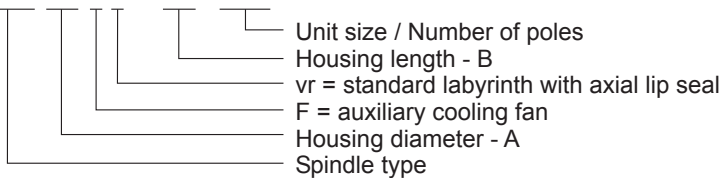

Max. speed for vr, see page 15.

Please state speed range and direction of rotation, see page 35, for information.

- 1) **Preference types** are in bold.
- 2) Power at 50 Hz.
- 3) Without tool.
Depending on tool design and weight the maximum operating speed may be reduced.
- 4) Max. speed for standard fan.
- 5) Speed for standard bearing application.
Marked = Speed for modified bearing application and if necessary a special motor.

1 mm = 0.03937 in.
1 kW = 1.34102 h.p.

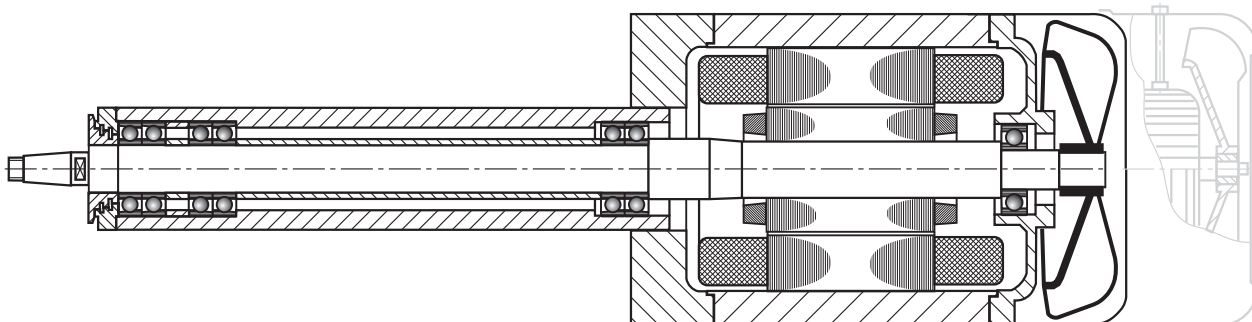

Technical Characteristics

- Spindle powered by an AC induction motor, with IP 54-protection rating, including PTC 145 and KTY 80-134 for over-temperature monitoring
- Precision ball bearing, in a solid arrangement
- Permanent grease lubricated
- External grinding taper
- Capable of operating from direct AC power supply or converter compatible for variable speed operation
- Auxiliary motors, dependent on speed and output power requirements
- The direction of rotation either **R** (right hand) or **L** (left hand) is determined by viewing the spindle from the rear as shown

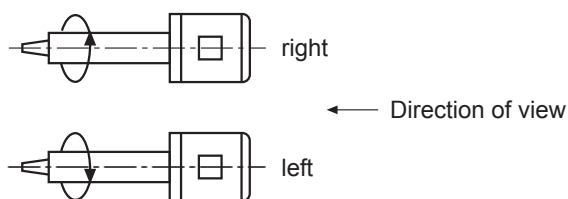

Ordering data

- Type designation _____ see chart on page 13
- Direction of rotation data _____
Option: From spindle diameter A = 50 deliverable for both direction of rotation types
- Maximum speed from _____ up to _____

Options

- Higher output power with lower decibel levels with an auxiliary cooling fan
- Automatic wheel balancing capabilities for 160 mm and larger, see page 29 / 31
Electronic control, see page 30

Accessories

- Flange
- Puller for flange TSEV
- Balancing quill for flange
- Tool for wheel change
- Storage and transport box
- Power cable

TSEV	Current [A] bei 230V/400V	Cable type
TSEV 50	2,25 / 1,3	SAK 18
TSEV 60	4,3 / 2,5	SAK 18
TSEV 80	7,5 / 4,3	SAK 18
TSEV 100, 2 poles	14 / 8,1	SAK 18
TSEV 100, 4 poles	14,9 / 8,6	SAK 18
TSEV 120, 2 poles	25,1 / 14,5	SAK 33
TSEV 120, 4 poles	26,8 / 15,4	SAK 33
TSEV 140, 2 poles	25,2 / 14,5	SAK 33
TSEV 140, 4 poles	26,8 / 15,4	SAK 33
TSEV 160, 4 poles	37,5 / 21,5	SAK 41
TSEV 160, 6 poles	39 / 22,5	SAK 41

- Thermistor amplifier

Sealing Options

Standard: Labyrinth seal

up to TSAV 100/
TSEV 100

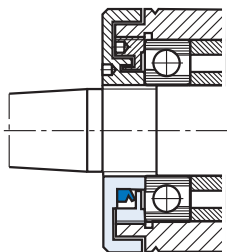

Option: Axial lip seal

Standard: Labyrinth seal with connection for air purge¹⁾

from TSAV 120/
TSEV 120

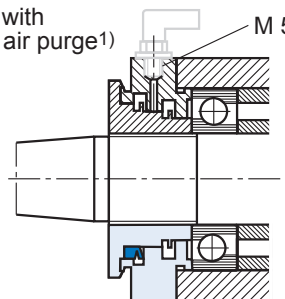

Option: Labyrinth seal with axial lip seal

The mechanical labyrinth seal design protects bearing system against the ingress of contamination during operation. The seal can be enhanced by the addition of an air purge port.

Spindle operating plane must be advised at the time of an order.

Contact type seals are available, depend upon maximum speed (see table at right).

Spindle Style	Speed limit (Sliding seal) [rpm]
TSAV 40	6300
TSAV 50/ TSEV 50	5000
TSAV 60/ TSAV 60	4100
TSAV 80/ TSEV 80	3100
TSAV 100/ TSEV 100	2400
TSAV 120/ TSEV 120	1700
TSAV 140/ TSEV 140	1600
TSAV 160/ TSEV 160	1300
TSAV 200	1000

¹⁾ Please note: The fitting is not part of the standard shipment.

Option

from TSA 50/
TSI 50/
TSP 50

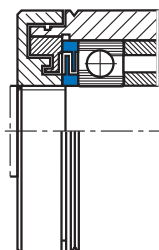

Sealing shields

Closely machined sealing shields can be incorporated into the TSA, TSI and TSP style spindles, to improve the sealing effects of the standard labyrinth seals. Radial stiffness will be slightly reduced.

Spindle speed [rpm]	Wheel diameter E [mm]																	
	4	5	6	8	10	13	16	20	32	40	50	63	80	100	125	175	200	250
80000	16,8	20,9	25,1	33,5	41,9	54,5	67,0	83,8										
70000	14,7	18,3	22,0	29,3	36,7	47,6	58,6	73,3										
60000	12,6	15,7	18,8	25,1	31,4	40,8	50,3	62,8										
55000	11,5	14,4	17,3	23,0	28,8	37,4	46,1	57,6	92,2									
50000	10,5	13,1	15,7	20,9	26,2	34,0	41,9	52,4	83,8									
45000		11,8	14,1	18,8	23,6	30,6	37,7	47,1	75,4	94,2								
40000		10,5	12,6	16,8	20,9	27,2	33,5	41,9	67,0	83,8								
35000			11,0	14,7	18,3	23,8	29,3	36,7	58,6	73,3	91,6							
33000			10,4	13,8	17,3	22,5	27,6	34,6	55,3	69,1	86,4							
32000			10,1	13,4	16,8	21,8	26,8	33,5	53,6	67,0	83,8							
30000				12,6	15,7	20,4	25,1	31,4	50,3	62,8	78,5	99,0						
27000				11,3	14,1	18,4	22,6	28,3	45,2	56,5	70,7	89,1						
25000				10,5	13,1	17,0	20,9	26,2	41,9	52,4	65,4	82,5						
24000				10,1	12,6	16,3	20,1	25,1	40,2	50,3	62,8	79,2						
23000					12,0	15,7	19,3	24,1	38,5	48,2	60,2	75,9	96,3					
22500					11,8	15,3	18,8	23,6	37,7	47,1	58,9	74,2	94,2					
21000					11,0	14,3	17,6	22,0	35,2	44,0	55,0	69,3	88,0					
20000					10,5	13,6	16,8	20,9	33,5	41,9	52,4	66,0	83,8					
19000						12,9	15,9	19,9	31,8	39,8	49,7	62,7	79,6	99,5				
18000						12,3	15,1	18,8	30,2	37,7	47,1	59,4	75,4	94,2				
16000						10,9	13,4	16,8	26,8	33,5	41,9	52,8	67,0	83,8				
15000							12,6	15,7	25,1	31,4	39,3	49,5	62,8	78,5	98,2			
14000							11,7	14,7	23,5	29,3	36,7	46,2	58,6	73,3	91,6			
13500							11,3	14,1	22,6	28,3	35,3	44,5	56,5	70,7	88,4			
13000							10,9	13,6	21,8	27,2	34,0	42,9	54,5	68,1	85,1			
12500							10,5	13,1	20,9	26,2	32,7	41,2	52,4	65,4	81,8			
12000							10,1	12,6	20,1	25,1	31,4	39,6	50,3	62,8	78,5			
11500								12,0	19,3	24,1	30,1	37,9	48,2	60,2	75,3			
11000								11,5	18,4	23,0	28,8	36,3	46,1	57,6	72,0			
10500								11,0	17,6	22,0	27,5	34,6	44,0	55,0	68,7	96,2		
10000								10,5	16,8	20,9	26,2	33,0	41,9	52,4	65,4	91,6		
9000									15,1	18,8	23,6	29,7	37,7	47,1	58,9	82,5	94,2	
8000									13,4	16,8	20,9	26,4	33,5	41,9	52,4	73,3	83,8	
7500									12,6	15,7	19,6	24,7	31,4	39,3	49,1	68,7	78,5	98,2
7000									11,7	14,7	18,3	23,1	29,3	36,7	45,8	64,1	73,3	91,6
6000									10,1	12,6	15,7	19,8	25,1	31,4	39,3	55,0	62,8	78,5
5500										11,5	14,4	18,1	23,0	28,8	36,0	50,4	57,6	72,0
5000										10,5	13,1	16,5	20,9	26,2	32,7	45,8	52,4	65,4
4000											10,5	13,2	16,8	20,9	26,2	36,7	41,9	52,4
2860													12,0	15,0	18,7	26,2	29,9	37,4
1440																13,2	15,1	18,8

Cutting speed v_C [m/s]

$$v_C = \frac{E \cdot \pi \cdot n}{60 \cdot 1000} \text{ [m/s]}$$

E = Wheel diameter [mm]
n = Spindle speed [1/min]

1 mm = 0.03937 in.
1 m = 1.09361 yd.



Flange style MO

Flange style MS

Spindle style	Attachment	Flange style	Flange dimensions [mm]			Grinding wheel [mm]			Max. speed ²⁾ [rpm]
			P	Q	L	E	F	G ¹⁾	
TSA 20	A 07	MO	20	6,5	1,5	25	8	13	27000
TSA 26	A 08	MO	26	5,5	3,5	36	10	16	20000
TSA 32	A 10	MO	32	6,5	3,5	50	13	20	15000
TSA 40	A 10	MS	40	6	6	63	16	25	12000
TSA 50	A 13	MS	50	6	9	80	20	32	10000
TSA 60	A 18	MS	60	7	9	100	25	32	8000
TSA 80	A 27	MS	80	9	10	125	32	51	6000
TSA 100	A 38	MS	100	15	13	150	40	76	5000

Ordering Information:

- Flange **A** ■ / ■ / ■
- Type of wheel:
 - D = Diamond or CBN
 - K = Corundum or Non diamond
 - Flange style = MO / MS
 - Attachment = A 07 / A 08 etc.
- Puller for flange **A** ■ / ■
- Flange style = MO etc.
 - Attachment = A 07 etc.
- Balancing quill for flange **A** ■
- Attachment = A 07 etc.

- 1) Wheel bore fits:
 - Corundum or Non diamond: G_{f7}
 - Diamond or CBN: G_{h4}
- 2) Wheel selection must be in accordance with the manufacturer's recommendation for maximum speed. Compliance with ANSI Safety Requirements B 7.1 must be adhered to.

⇒ Balancing Specifications:
 For safety reasons, noise levels, and finish quality all rotating components including the grinding wheels must be balanced.
 GMN recommend balancing the system within G 2.5 level, according to ISO 1940.

Please state direction of rotation, see page 35, for information.

1 mm = 0.03937 in.

Fig. 1

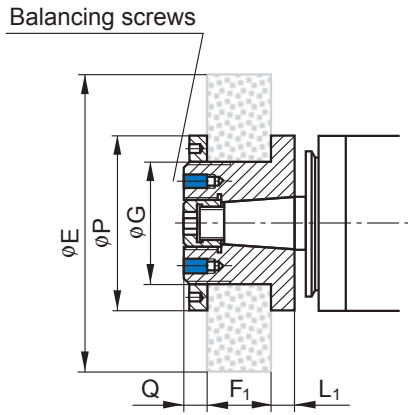

Flange style MS

Fig. 2

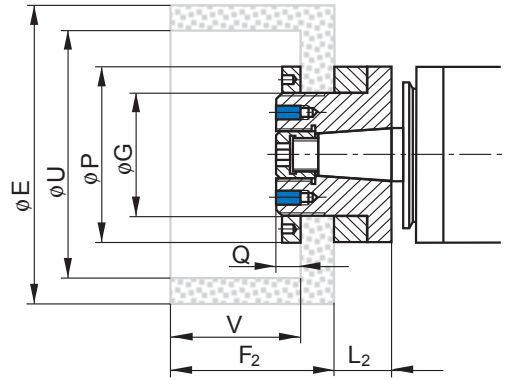

Flange style MS

Fig. 3

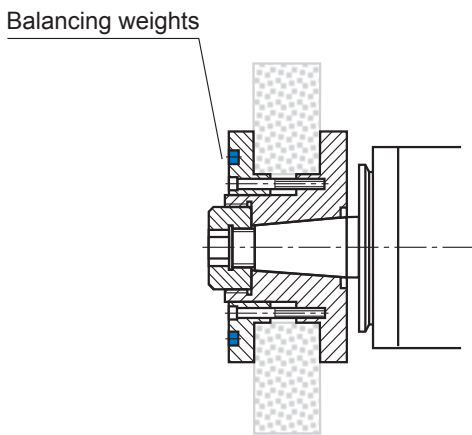

Flange style SN

Fig. 4

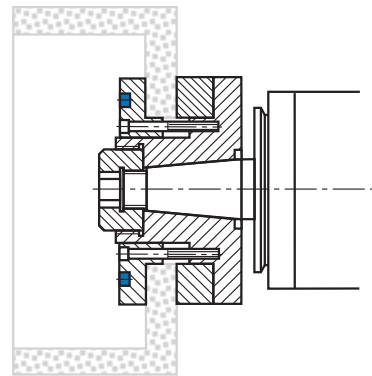

Flange style SN

Spindle Style	Attachment	Fig.	Flange dimensions [mm]				Grinding wheel [mm]				Max. speed ²⁾ ($v_c = 35 \text{ m/s}$) [rpm]		
			P	Q	L ₁	L ₂	E	G ¹⁾	Straight wheel F ₁ (Spannbereich)	Cup wheel F ₂ U V			
TSAV 40	V 12	1+2	40	6	6	14	100	25	16 (11-16)	50	90	42	6600
		1	40	6	6	---	80	25	16 (11-16)	---	---	---	8300
TSAV 50 / TSEV 50	V 15	1+2	50	6	9	19	125	32	20 (14-20)	63	110	53	5300
		1	50	6	9	---	100	32	20 (14-20)	---	---	---	6600
TSAV 60 / TSEV 60	V 20	1+2	60	7	9	21	150	40	25 (17-25)	80	130	67	4400
		2	60	7	9	---	125	40	25 (17-25)	---	---	---	5300
TSAV 80 / TSEV 80	V 27	1+2	80	9	10	22	200	51	32 (21-32)	100	170	80	3300
		2	80	9	10	---	150	51	32 (21-32)	---	---	---	4400
TSAV 100 / TSEV 100	V 38	3+4	110	13	13	28	250	76	40 (20-40)	125	190	100	2600
		1+2	110	13,5	13	30	175	76	40 (30-40)	---	---	---	3800
TSAV 120 / TSEV 120	V 52	3+4	165	16	16	44	350	127	60 (25-60)	150	235	118	1900
		1	120	15	16	---	200	76	60 (45-60)	---	---	---	3300
TSAV 140 / TSEV 140	V 56	3+4	180	18	18	46	450	127	60 (32-60)	150	260	118	1400
		1	140	14	18	---	250	76	60 (46-60)	---	---	---	2600
TSAV 160 / TSEV 160	V 87	3+4	270	22	22	---	600	203	80 (40-80)	---	---	---	1100
TSAV 200	V 87	3+4	270	22	22	---	600	203	80 (40-80)	---	---	---	1100

Ordering Information:

Flange V ■ / ■ / ■ / ■

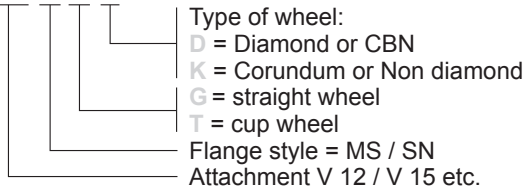

Puller for flange V 12 / V 15 etc.

Balancing quill for flange V 12 / V 15 etc.

1) Wheel bore fits:

Corundum or Non diamond: G_{f7}

Diamond or CBN: G_{h4}

2) Wheel selection must be in accordance with the manufacturer's recommendation for maximum speed. Compliance with ANSI Safety Requirements B 7.1 must be adhered to.

TSAV / TSEV 50 - 80:

- Flange style MS (Fig. 1, 2):
Option: anti-rotation slot

From TSAV / TSEV 100:

- Flange style SN (Fig. 3, 4):
Standard: anti-rotation slot

Please state direction of rotation, see page 35, for information.

1 mm = 0.03937 in.
1 m = 1.09361 yd.

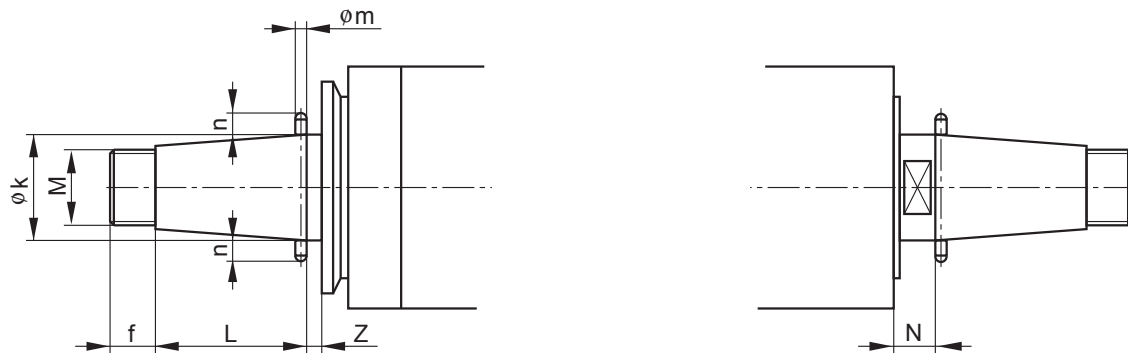

Spindle Style	Attachment	Attachment dimensions [mm]			Dimensions [mm]				
		k	L	M	f	m	n	Z	N
TSAV 40	V 12	12,83	15	M 10 x 1	7				
TSAV 50	V 15	15,5	20	M 12 x 1	7	3	3	3	8
TSAV 60	V 20	20	25	M 16 x 1	10	3	3	3	9
TSAV 80	V 27	27,67	35	M 20 x 1	12	4	3	4	12
TSAV 100	V 38	38	52,5	M 30 x 1	12,5	5	4	4	15
TSAV 120	V 52	52	65	M 36 x 1	17,5	6	5	5	18
TSAV 140	V 56	56	75	M 40 x 1,5	17,5	6	5	5	18
TSAV 160	V 87	87	110	M 65 x 1,5	20	8	6	6	21
TSAV 200	V 87	87	110	M 65 x 1,5	20	8	6	6	24
TSEV 50	V 15	15,5	20	M 12 x 1	7	3	3	8	
TSEV 60	V 20	20	25	M 16 x 1	10	3	3	9	
TSEV 80	V 27	27,67	35	M 20 x 1	12	4	3	12	
TSEV 100	V 38	38	52,5	M 30 x 1	12,5	5	4	15	
TSEV 120	V 52	52	65	M 36 x 1	17,5	6	5	18	
TSEV 140	V 52	56	75	M 40 x 1,5	17,5	6	5	18	
TSEV 160	V 87	87	110	M 65 x 1,5	20	8	6	24	

1 mm = 0.03937 in.

Taper Specifications

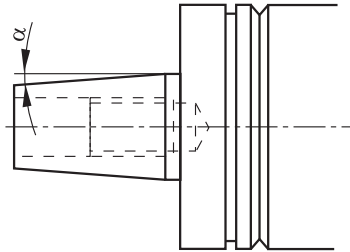

Spindle Style	Attachment	Taper angle α
TSA 20	A 07	3° 50' 03"
TSA 26	A 08	3° 49' 33"
TSA 32	A 10	3° 49' 19"
TSA 40	A 10	3° 49' 19"
TSA 50	A 13	3° 48' 28"
TSA 60	A 18	3° 48' 13"
TSA 80	A 27	3° 48' 55"
TSA 100	A 38	3° 50' 28"

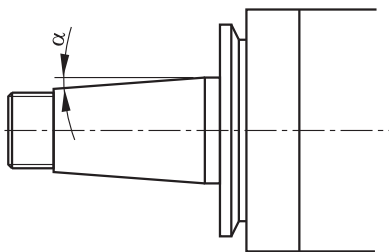

Spindle Style	Attachment	Taper angle α
TSAV 40	V 12	3° 49' 15"
TSAV 50 / TSEV 50	V 15	3° 49' 06"
TSAV 60 / TSEV 60	V 20	3° 48' 51"
TSAV 80 / TSEV 80	V 27	3° 48' 55"
TSEV 100 / TSAV 100	V 38	3° 50' 28"
TSAV 120 / TSEV 120	V 52	3° 48' 51"
TSAV 140 / TSEV 140	V 56	3° 49' 27"
TSAV 160 / TSEV 160	V 87	3° 48' 48"
TSAV 200	V 87	3° 48' 48"

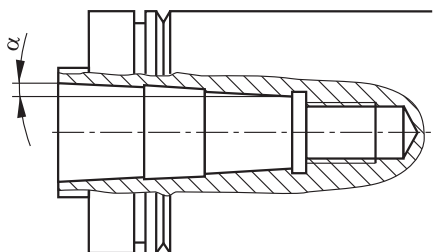

Spindle Style	Attachment	Taper angle α
TSI 40	I 10	3° 49' 00"
TSI 50	I 14	3° 48' 42"
TSI 60	I 18	3° 48' 52"
TSI 80	I 25	3° 48' 49"
TSI 100	I 32	3° 49' 00"

Taper angle α according to GMN standard.

Tooling Accessories

TSA - Collet Chuck

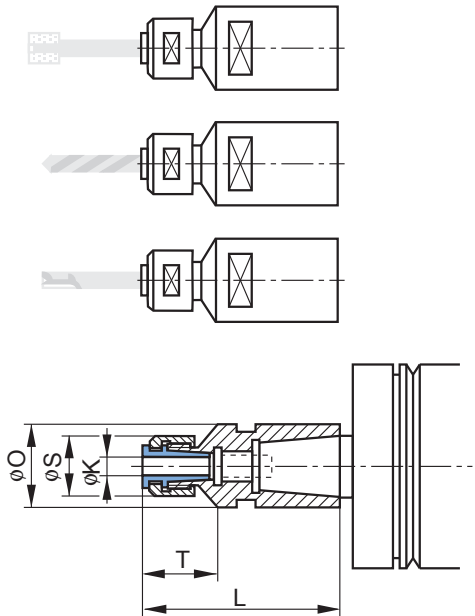

TSA - Grinding Quill

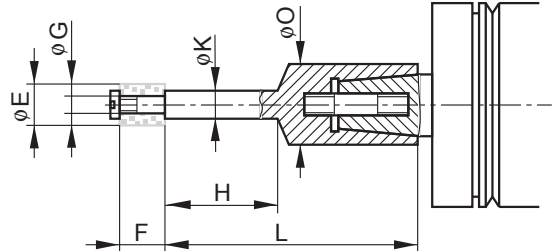

Spindle Style	Attachment	Dimensions [mm]				
		K	T	L	S	O
TSA 20	A 07	2 3 4	13,5	36	14	10,5
TSA 26	A 08	2 3 4	13,5	37	14	12
TSA 32	A 10	2 3 4	13,5	37	14	13,5
TSA 40	A 10	3 4 5 6	15,5	42	16	13,5
TSA 50	A 13	3 4 5 6	15,5	47	16	18
TSA 60	A 18	3 4 5 6	15,5	54	16	23
TSA 80	A 27	6 8 10 12	27	87	35	34

Ordering Information:

Collet chuck **A** ■ / ■
 — Housing diameter = 20 / 26 etc.
 — Attachment = A 07 / A 08 etc.

Clamping chuck for collet chuck **A** ■ / ■ - ■
 — K
 — Housing diameter = 20 etc.
 — Attachment = A 07 etc.

Please state direction of rotation, see page 35, when ordering.

1 mm = 0.03937 in.

Tooling Accessories

TSI - Collet Chuck

TSP - Clamping Chuck

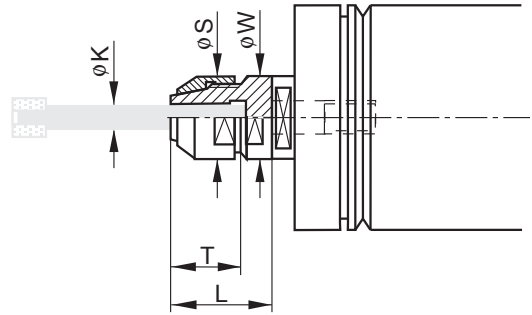
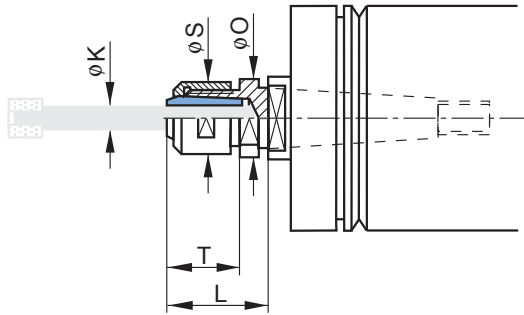

Spindle Style	Attachment	Dimensions [mm]				
		K	T	L	S	O
TSI 40	I 10	3	15,5	25	16	13,5
		4				
		5				
		6				
TSI 50	I 14	3	15,5	25	16	18
		4				
		5				
		6				
TSI 60	I 18	3	15,5	28	16	23
		4				
		5				
		6				
TSI 80	I 25	6	36	43	35	34
		8				
		10				
		12				

Spindle Style	Attachment D [d] / [W]	Dimensions [mm]			
		K	T	L	S
TSP 40	D 08/14	3	20	26	14
TSP 50	D 10/18	6	20	30	18
TSP 60	D 14/23	6	20	30	23

Ordering Information:
Clamping chuck **D 08/14** etc.

Please state direction of rotation, see page 35, when ordering.

Ordering Information:

Collet chuck I ■ Attachment = I 10 / I 14 etc.

Clamping chuck for collet chuck I ■ - ■ K Attachment = I 10 / I 14 etc.

Please state direction of rotation, see page 35, when ordering.

1 mm = 0.03937 in.

Spindle type	Surface speeds at maximum spindle speed [m/s]								Spindle nose			
	23	29	37						Designation	H ₀	SW	
TSP 40 c									D 08/14	6	13	
TSP 40	19	24	31						D 08/14	6	13	
TSP 50 c		22	29	35	44				D 10/18	8	16	
TSP 50		18	24	29	37				D 10/18	8	16	
TSP 60 c			24	29	37	46			D 14/23	8	21	
TSP 60			20	25	31	39			D 14/23	8	21	
TSP 80 c				21	26	33	42		D 16/33	10	27	
TSP 80				17	21	26	34		D 16/33	10	27	
TSP 100 c						26	34	42	52	D 28/43	12	38
TSP 100						20	25	31	39	D 28/43	12	38

TSI 40 c	23	29	37							I 10	5	11
TSI 40	19	24	31							I 10	5	11
TSI 50 c		22	29	35	44					I 14	6	15
TSI 50		18	24	29	37					I 14	6	15
TSI 60 c			24	29	37	46				I 18	6	19
TSI 60			20	25	31	39				I 18	6	19
TSI 80 c				21	26	33	42			I 25	8	27
TSI 80				17	21	26	34			I 25	8	27
TSI 100 c						26	34	42	52	I 32	10	41
TSI 100						20	25	31	39	I 32	10	41

For wheel dimensions [mm]	E	8	10	13	16	20	25	32	40	50	
	F	10	10	13	16	20	25	25	32	40	
	G	3	3	4	6	8	10	13	16	20	
Quill diameter	K	5	6	8	10	13	16	20	25	32	
Wheel mount		KI	KI	PS	PS	PS	PS	PS	MU	MU	
	see fig.	2	2	3+4	3+4	3+4	3+4	3+4	5	5	
Close-fit hole attachment	d ₁			4	6	8	10	13			
	M ₁			M3	M5	M6	M8	M12			
	L ₅			5	7	9	12	13			
	L ₆			8	11	12	14	17			

Quill stiffness [N/μm]		Grinding quill diameter K [mm]								
		5	6	8	10	13	16	20	25	32
Grinding quill length H [mm]	16	4,7	9,8							
	20	2,4	5,0	15,8	38,7					
	25	1,2	2,6	8,1	19,8	56,5				
	32			3,9	9,4	27	61,9	151		
	40				4,8	13,8	31,7	77,3	189	
	50					7,1	16,2	39,6	96,6	259
	63						8,1	19,8	48,3	130
	80								23,6	63,3
	100									32,4

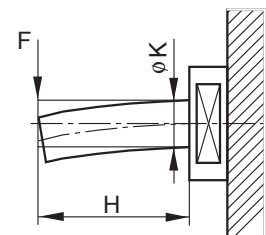

1 mm = 0.03937 in.
 1 m = 1.09361 yd.
 1 N/μm = 5710 lb./in.

Figures 2 through 5 are examples for quill applications.

Fig. 2: TSP - Cemented wheel (KI)

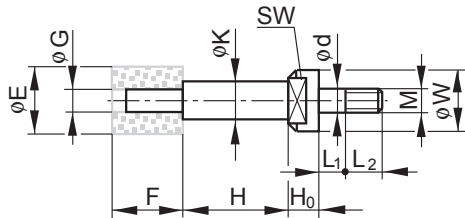

Fig. 3: TSP - Close-fit wheel screw (PS)

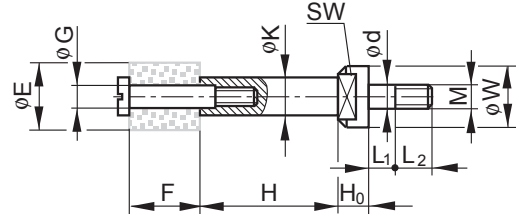

Fig. 4: TSP - Threaded wheel studs (PS)

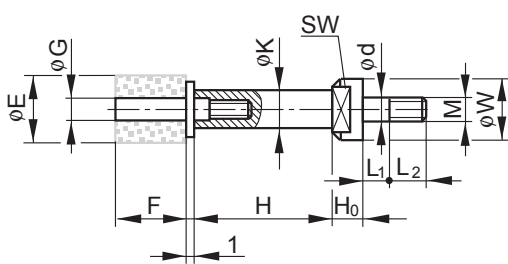

Fig. 5: TSP - Quill with nut (MU)

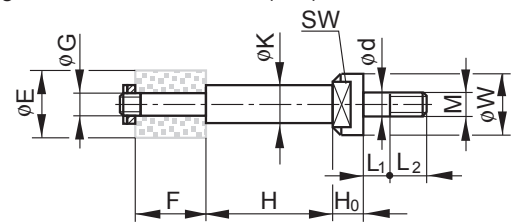

Fig. 2: TSI - Cemented wheel (KI)

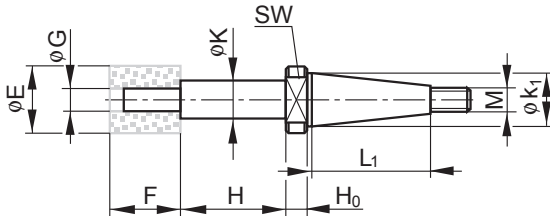

Fig. 3: TSI - Close-fit wheel screw (PS)

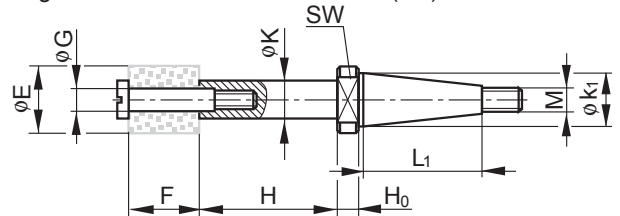

Fig. 4: TSI - Threaded wheel studs (PS)

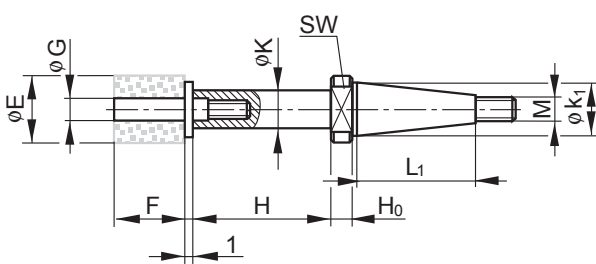
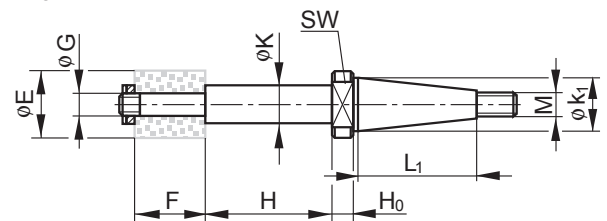
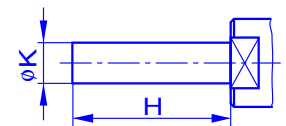

Fig. 5: TSI - Quill with nut (MU)



TSP - / TSI - Grinding Quills - Semifinished

Semifinished Quills	Attachment	K [mm]	H [mm]	Attachment	Semifinished Quills
TSP 40 (c)	D08/14	13	70	I 10	TSI 40 (c)
TSP 50 (c)	D10/18	18	90	I 14	TSI 50 (c)
TSP 60 (c)	D14/23	23	135	I 18	TSI 60 (c)
TSP 80 (c)	D16/33	33	180	I 25	TSI 80 (c)
TSP 100 (c)	D28/43	43	240	I 32	TSI 100 (c)



1 mm = 0.03937 in.

		Maximum speed [rpm]			
Spindle nose interface: D 08/14 I 10		H [mm]			
Spindle designation	K [mm]	< 16	20	25	32
TSP 40 c TSI 40 c	5	54000			
	6	55000	53000		
	8	55000	55000	52000	50000
TSP 40 TSI 40	5	45000			
	6	45000	45000		
	8	45000	45000	45000	45000
Spindle nose interface: D 10/18 I 14		H [mm]			
Spindle designation	K [mm]	< 25	32	40	
TSP 50 c TSI 50 c	6	42000			
	8	42000	42000		
	10	42000	42000	42000	
TSP 50 TSI 50	6	35000			
	8	35000	35000		
	10	35000	35000	35000	
Spindle nose interface: D 14/23 I 18		H [mm]			
Spindle designation	K [mm]	< 32	40	50	63
TSP 60 c TSI 60 c	8	35000			
	10	35000	35000	30000	
	13	35000	35000	35000	
	16	35000	35000	35000	35000
TSP 60 TSI 60	8	30000			
	10	30000	30000	30000	
	13	30000	30000	30000	
	16	30000	30000	30000	30000
Spindle nose interface: D 16/33 I 25		H [mm]			
Spindle designation	K [mm]	< 63	80		
TSP 80 c TSI 80 c	10	25000			
	13	25000	25000		
	16	25000	25000		
	20	25000	25000		
TSP 80 TSI 80	10	20000			
	13	20000	20000		
	16	20000	20000		
	20	20000	20000		
Spindle nose interface: D 28/43 I 32		H [mm]			
Spindle designation	K [mm]	< 80	100	125	160
TSP 100 c TSI 100 c	16	20000			
	20	20000	20000		
	25	20000	20000	18000	
	32	20000	20000	20000	18000
TSP 100 TSI 100	16	15000			
	20	15000	15000		
	25	15000	15000	15000	
	32	15000	15000	15000	15000

1 mm = 0.03937 in.

Pulleys

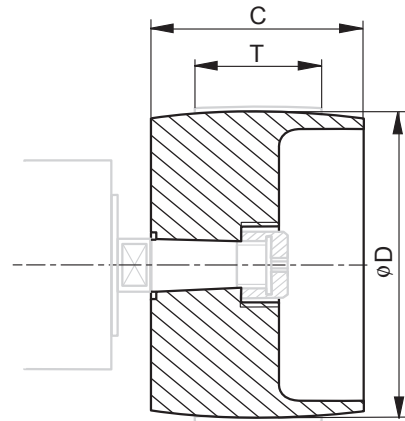
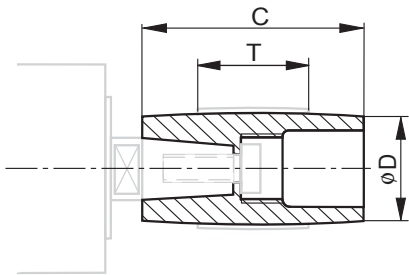

For Spindle TSA, TSI, TSP	Dimensions [mm]		
	D	C	T
A 07	14 28	20	10
A 08	16 36	25	15
A 10	18 50	30	20
	17 20 25 63	40	
	20 25 35 80	50	
	25 32 40 100	60	
A 27	40 45 50 56 125	70	50
	50 63 160	80	60

For Spindle TSAV	Dimensions [mm]		
	D	C	T
V 12	40 50	40	30
V 15	50 63	50	40
V 20	63 80	60	50
V 27	80 100	70	60
V 38	80 125	80	50
V 52	90 160	100	80
V 56	120 210	100	80
V 87	280	130	100

Ordering Information:

Pulley **A** ■ - ■
 └───┬───┬───
 D C T
 Attachment A 07 / A 08 etc.
 Puller for pulley **A 07 / A 08** etc.

Pulley **V** ■ - ■
 └───┬───┬───
 D C T
 Attachment V 12 / V 15 etc.
 Puller for pulley **V 12 / V 15** etc.

V 15 - V 27 (TSAV 50 - TSAV 80):

- Option: anti-rotation slot

From V 38 (TSAV 100):

- Standard: anti-rotation slot

1 mm = 0.03937 in.

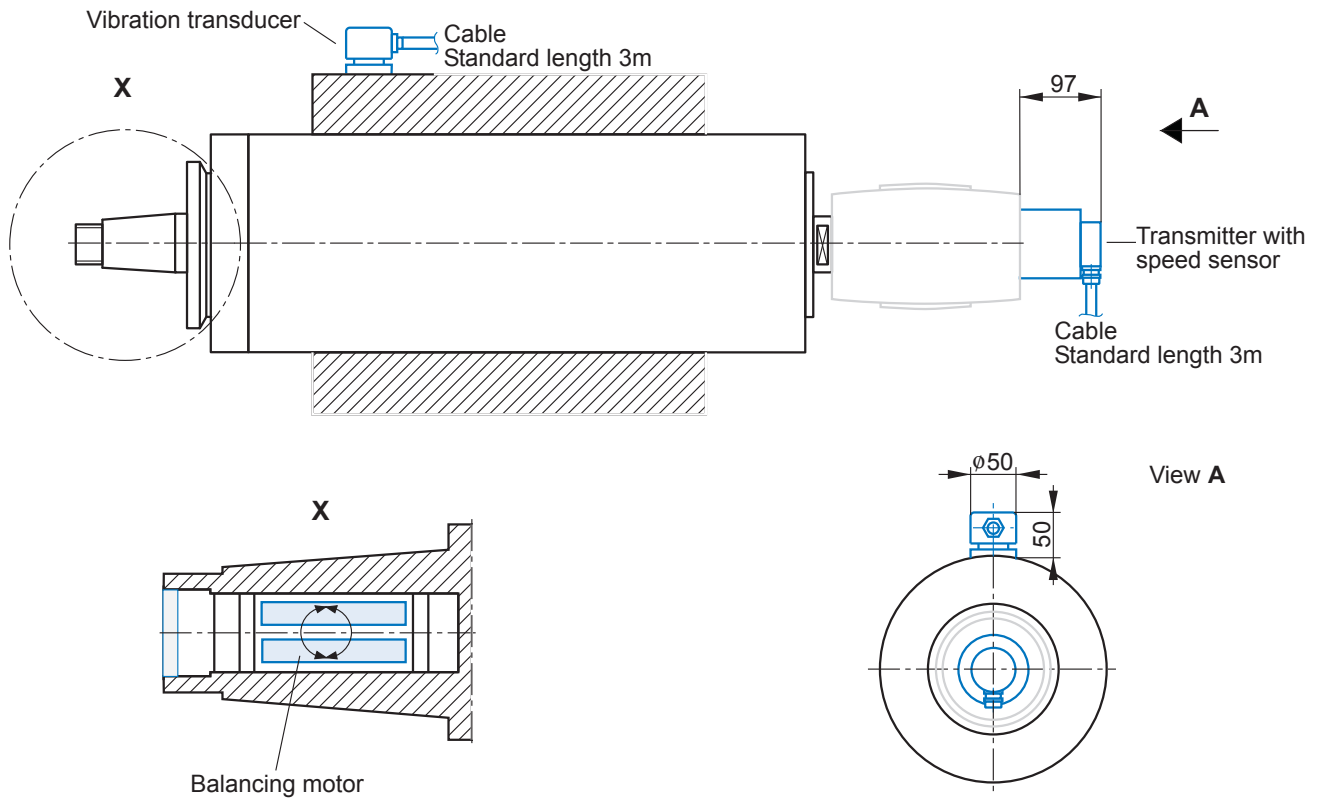

**Electromechanical balancing system
TSAV-Spindles
with housing diameter 160 and 200 mm**

TSAV 160 x 400	TSAV 200 x 400
TSAV 160 x 500	TSAV 200 x 500
TSAV 160 x 630	TSAV 200 x 630

consisting of:

- Balancing motor
- Vibration transducer
- Transmitter with speed sensor

- Options:
- Extension cable for vibration transducer
 - Extension cable for balancing motor

Electronic control, see page 30

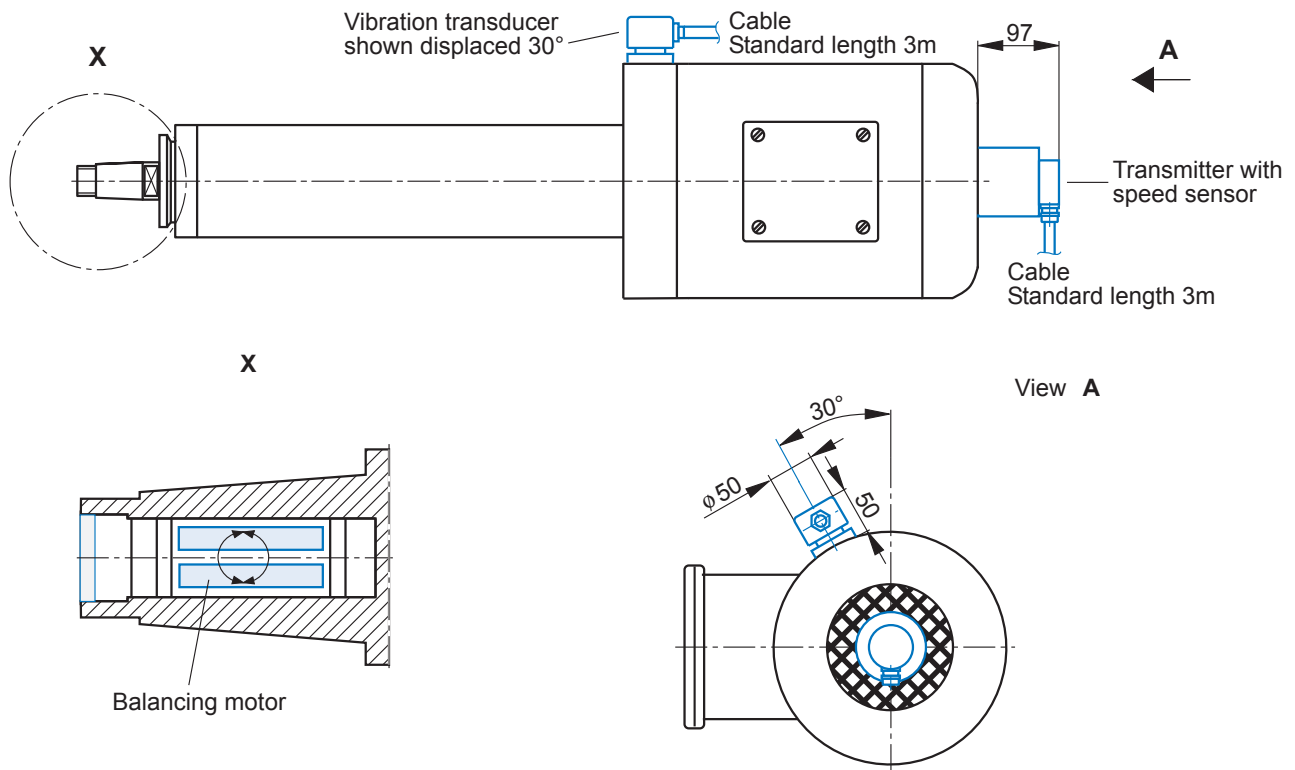

**Electromechanical balancing system
TSEV-Spindles
with Housing diameter 160 mm**

TSEV 160 x 400 - ...
TSEV 160 x 500 - ...

consisting of:

- Balancing motor
- Vibration transducer
- Transmitter with speed sensor

Options: • Extension cable for vibration transducer
• Extension cable for balancing motor

Electronic control, see page 30

Automatic Balancing System

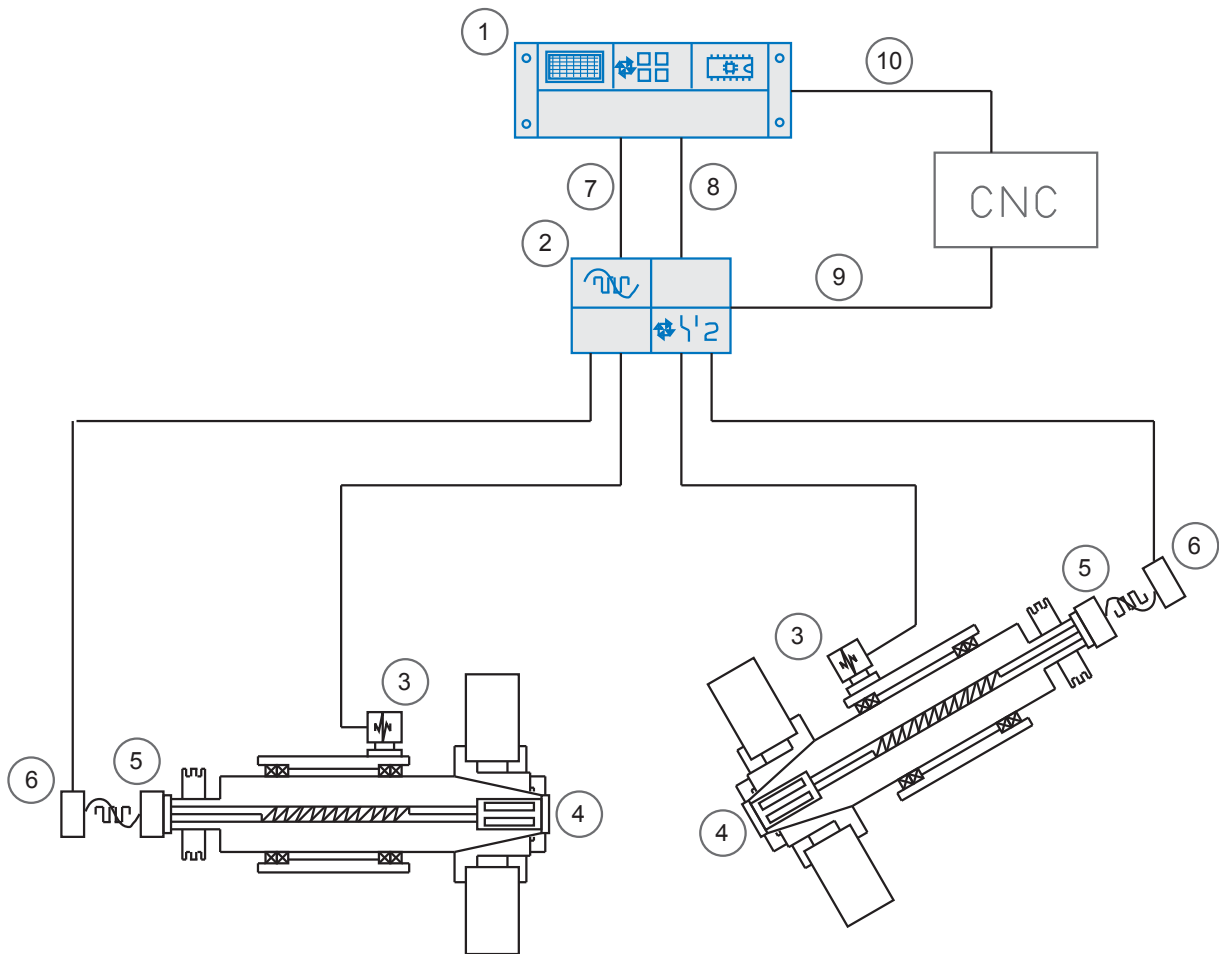

- ① Electronic control
- ② Multiplexer is required for multi spindle machines

Included in the delivery of the spindle:

- ③ Vibration transducer with 3m cable
Option: Extension cable
- ④ Internal balancing sensor
- ⑤ Receiver
- ⑥ Transmitter with integrated speed sensor
3m cable
Option: Extension cable

Accessories:

- ⑦ Extension cable
- ⑧ Extension cable
- ⑨ Extension cable

Please state length when ordering.

Portable Unit For Manual Balancing

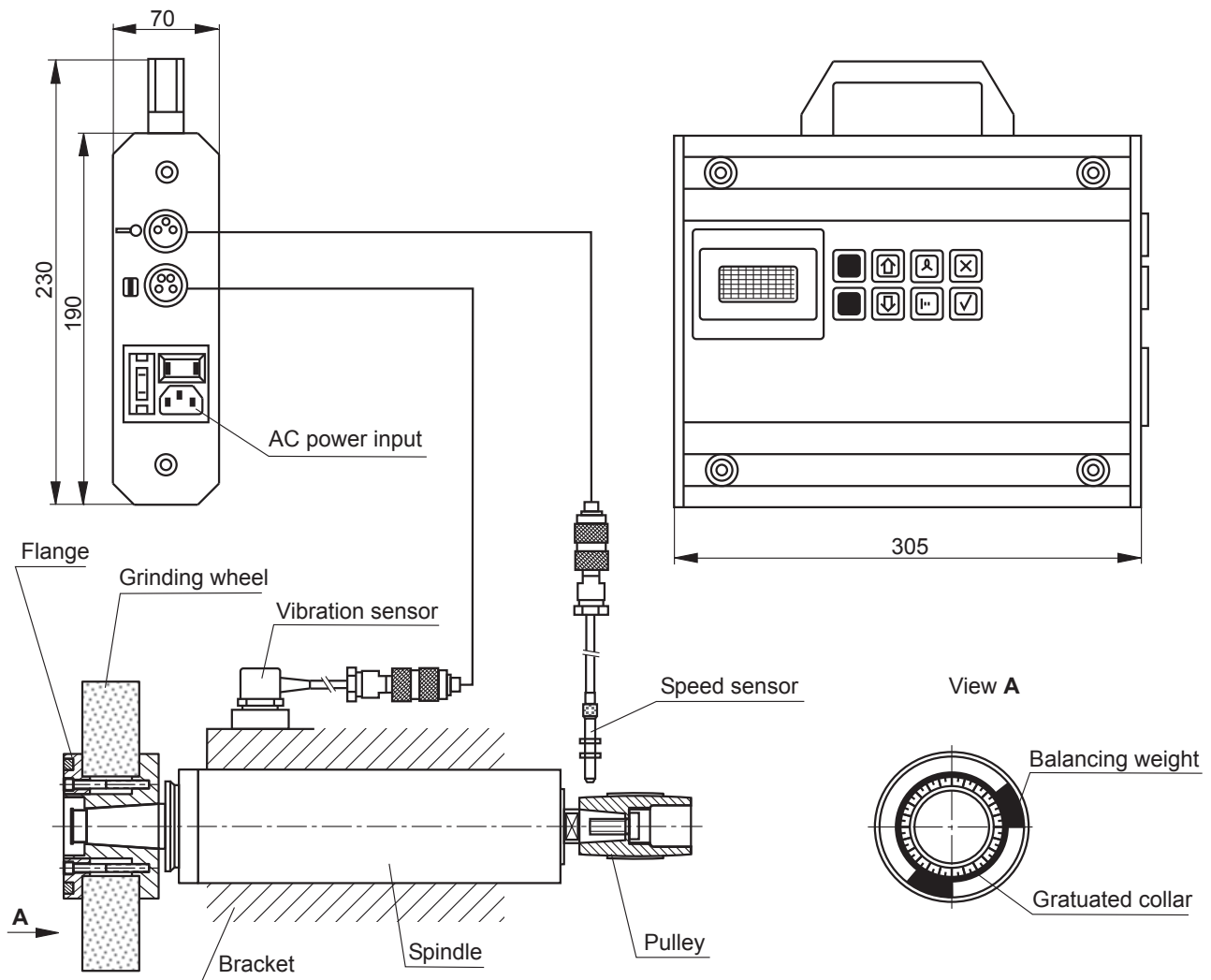

Every rotating part incorporates a degree of unbalance, which causes sinuous vibration during rotation. To reduce the effect of unbalancing forces, the unbalancing mass of all rotating parts has to be limited. Shafts and all rotating components of GMN high precision spindles are always balanced. As a result of higher cutting speeds this process is also required for tools. For large spindles automatic balancing systems are available. We recommend the portable balancing system for smaller spindles.

Process

- The vibration transducer with a magnetic base is attached to either the spindle housing or mounting bracket
- Speed sensor must be positioned to read the speed of the spindle
- Portable unit automatically:
 - Records the spindle speed
 - Records vibration levels
 - Indicates the amount and position of unbalance
 - Calculates and indicates the corrected results
- To fix the balancing weight
- Control and if necessary correction

Stiffness - Load Capacity

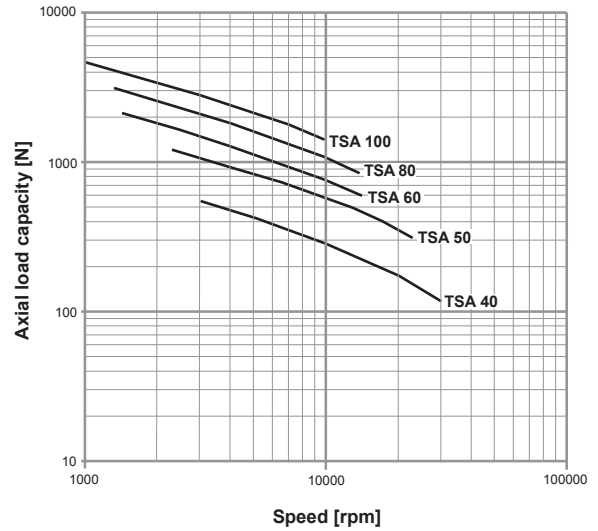
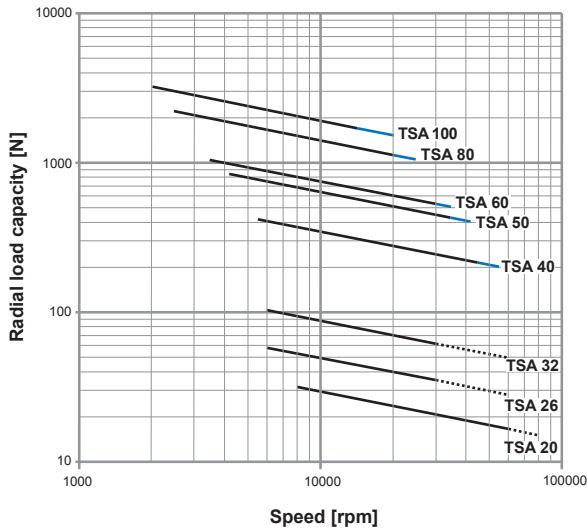

Style	Stiffness [N/μm]		Load capacity [N]		
	axial A u. B	radial	axial A B		radial
TSA 20 x 125 TSA 20 x 160	12	3,5	70 ¹⁾	35 ¹⁾	see diagram
TSA 20 x 200 TSA 20 x 250	17	3,5	70 ¹⁾	70 ¹⁾	
TSA 26 x 125 TSA 26 x 160 TSA 26 x 200	14	5,0	70 ¹⁾	35 ¹⁾	
TSA 26 x 250 TSA 26 x 315	20	5,0	70 ¹⁾	70 ¹⁾	
TSA 32 x 125 TSA 32 x 160 TSA 32 x 200	15	8,0	70 ¹⁾	35 ¹⁾	
TSA 32 x 250 TSA 32 x 315 TSA 32 x 355	21	8,0	70 ¹⁾	70 ¹⁾	
TSA 40* TSA 50* TSA 60*	32 41 51	25 41 57	see diagram	150 225 300	
TSA 80* TSA 100*	67 78	96 113		450 540	

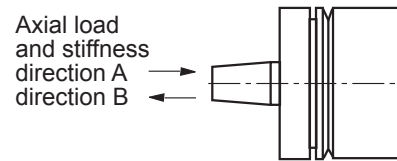
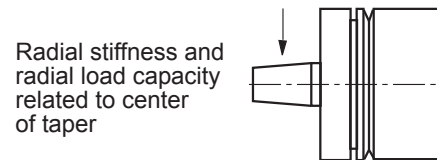

* Data applicable to all spindle length.

¹⁾ For low speed operation (<0.4 catalog specified speed). Axial load of 2 to 3 times higher than indicated can be applied, for short periods, depending on noise and vibration levels.

$$1 \text{ N} = 0.2248 \text{ lb}_f$$

$$1 \text{ N}/\mu\text{m} = 5710 \text{ lb./in.}$$

Stiffness - Load Capacity

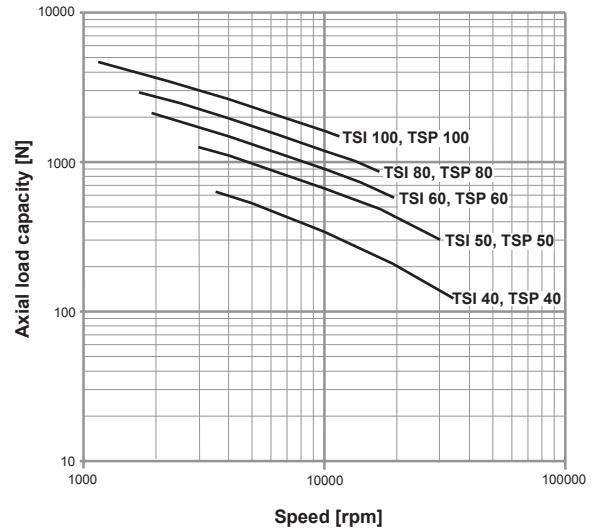
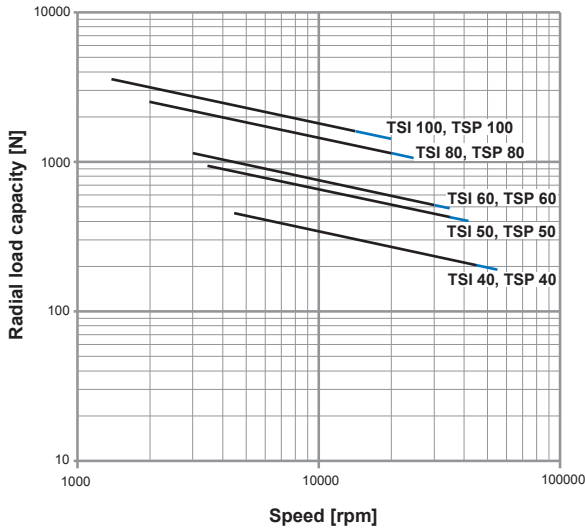

Style	Stiffness [N/μm]		Load capacity [N]		
	axial A u. B	radial	axial A	B	radial
TSI / TSP 40	32	36	see diagram	150	see diagram
TSI / TSP 50	41	65		225	
TSI / TSP 60	51	85		300	
TSI / TSP 80	67	140	450		
TSI / TSP 100	78	170	540		

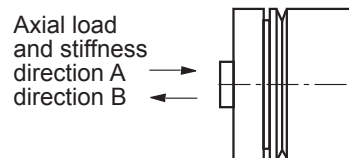
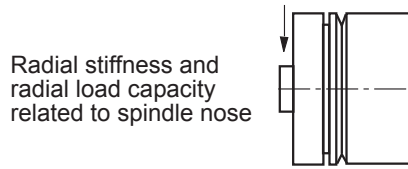

Data applicable to all spindle lengths.

The data provided is to serve as a guide for the proper selection of spindles for a particular application.

The load capacities provided are for either pure radial or axial loads. Combined loads can not be used at the maximum values. Application should be analyzed by GMN Engineering Department for proper spindle selection.

The data can be used as a reference to suit your application and selection of a spindle to meet your requirements. GMN Engineering should be provided with all pertinent data to review each application to provide the optimum spindle for your application.

5000 hours of B₁₀ bearing life were used as a minimum for the calculation of spindle capacity.

Axial and radial stiffness' calculation are static values.

1 N	=	0.2248 lb _f
1 N/μm	=	5710 lb./in.

Stiffness - Load Capacity

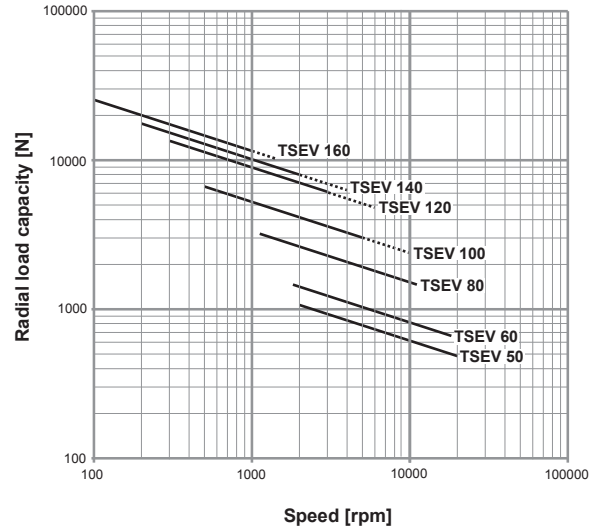
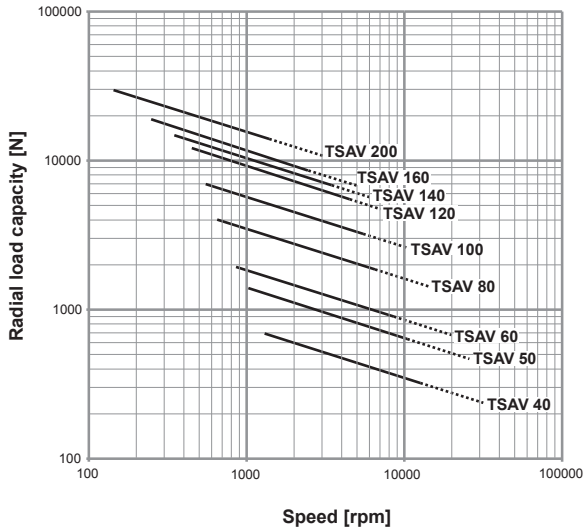

Radial stiffness and radial load capacity related to center of taper

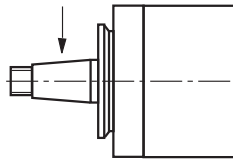

Axial load and stiffness in direction A and B is equal

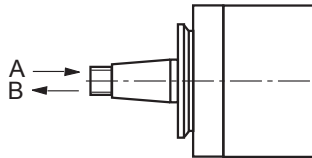

Radial stiffness and radial load capacity related to center of taper

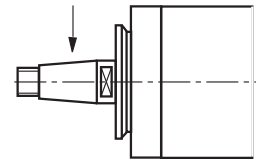

Axial load and stiffness in direction A and B is equal

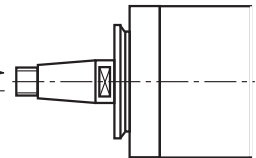

Style	Stiffness [N/μm]		Load capacity [N]		
	axial	radial	axial ¹⁾	radial	
TSAV 40	56	29	300		see diagram
TSAV 50	75	37	600		
TSAV 60	90	60	600		
TSAV 80	133	75	1500		
TSAV 100	165	108	2400		
TSAV 120	212	170	3000		
TSAV 140	230	170	3600		
TSAV 160	300	245	4800		
TSAV 200	345	342	6000		

Style	Stiffness [N/μm]		Load capacity [N]		
	axial	radial	axial ¹⁾	radial	
TSEV 50	75	28	600		see diagram
TSEV 60	90	45	600		
TSEV 80	133	56	1500		
TSEV 100	165	80	2400		
TSEV 120	212	132	3000		
TSEV 140	230	132	3600		
TSEV 160	300	195	4800		

Data applicable to all spindle lengths.

Data applicable to all spindle lengths.

¹⁾ Axial load of 2 to 3 times higher than indicated can be applied, depending on noise and vibration levels.

1 N	= 0.2248 lb _f
1 N/μm	= 5710 lb./in.

Guidelines

Choosing the proper spindle and accessories is essential in obtaining quality grinding performance, long operating life, and operator safety.

GMN's extensive manufacturing program can satisfy all your requirements.

Selection criteria:

1. Choose the spindle with the largest diameter and the shortest length possible.
2. Choose quills, flanges and other wheel mounting accessories as large, robust and compact as possible.
3. Choose the largest spindle, with the necessary speed requirements, as recommended by the wheel manufacturer, or a spindle with slightly higher capabilities. This will assure maximum bearing life.
4. If possible always select a direct motorized style over the belt driven design. The total system is more compact, speed changes are effortless, and belt tensioning is eliminated.
5. Always provide the direction of rotation of the wheel, when looking into the pulley end of the spindle.

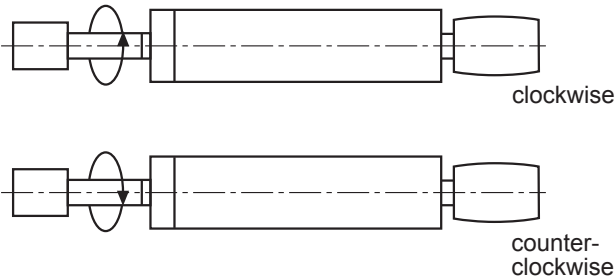

Grinding Wheels

The grinding wheel sizes illustrated in the catalog correspond to DIN 69 120 standards. To select the proper wheel for each application, please consult with the wheel manufacturer.

Grinding wheel speeds and use must adhere to the corresponding regulations for safety. ANSI B7.1 "Safety Requirements for USE, Care and Protection of Abrasive Wheels".

Safety guards or protection hoods must be used when the wheel size reaches a 2 inch diameter and larger. For all internal grinding applications, hinged or swivel type wheel guards are required to protect the operator.

Wheels must be mounted between steel or cast iron flanges, in compliance with the minimum dimensional size at various points, bearing area, reliefs and commonality as specified in the ANSI or DIN standards.

Both flanges must be alike in diameter and bearing area. Mounting of wheels between dissimilar flanges is one of the most common causes of wheel failure.

Flange diameters must not be less than 1/3 of the grinding wheel diameter.

Wheels must be properly fit to spindles or mounting devices. Never force a wheel onto the mounting surface, also the fits should not be too loose. The clearances should be between 0.002" to 0.003" for small wheels and 0.010" to 0.012" for larger bores.

Blotters (compressible washers – paper) shall always be used between the flanges and grinding wheels. Most wheels are supplied with blotters already mounted.

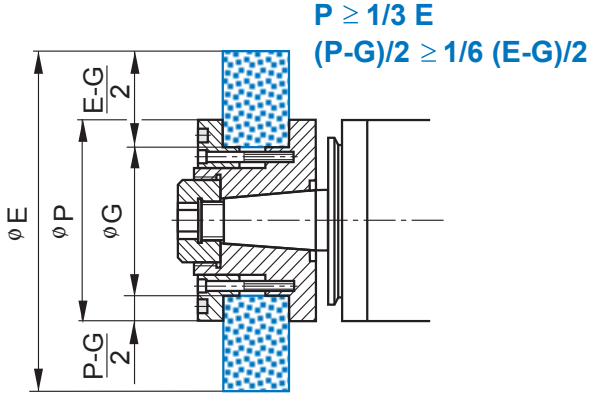

Small diameter wheels are cemented to the quill or arbors, which provides the following advantages.

No wheel breakage, due to tightening, better balance quality due to the elimination of locknuts, and a quieter operation, and smoother performance.

Unbalanced State

Every spindle shaft and every tool incorporates a degree of unbalance, which causes sinuous vibration during rotation. To reduce the effect of unbalancing forces, the unbalancing mass of all rotating parts has to be limited. Shafts of GMN high frequency spindles are always balanced.

As a result of higher cutting speeds this process is also required for tools.

We recommend for precision cutting a permissible residual unbalance for tools according to the following diagram:

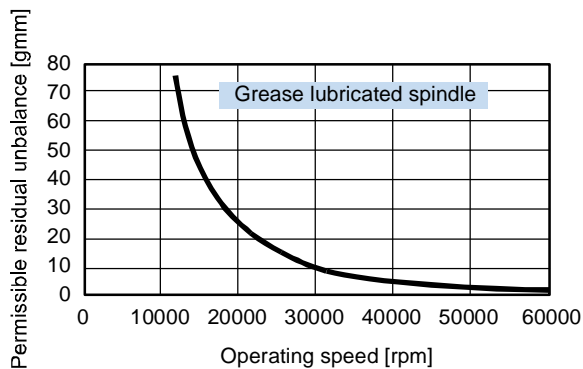

Critical Speed

GMN machining spindles are designed so that the critical speeds remain above the maximum speed. When using inappropriate tooling the critical speed can be decreased to a level within the operating speed range.

This can lead to poor part quality, decreased spindle performance, as well as jeopardizing the safety of the operator and machine.

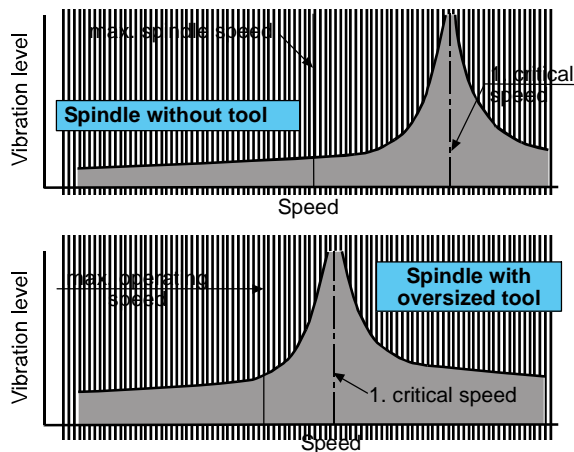

We recommend consulting our application engineering staff when tools which are extremely long and heavy are to be used.

Let GMN analyse your spindle and tooling requirements with our specifically designed computer software. In addition to the critical frequencies the static and dynamic stiffness and load carrying capacity of each single bearing can be calculated.

Through proper analysis the correct spindle can be selected or tips for improvement of tools can be made.

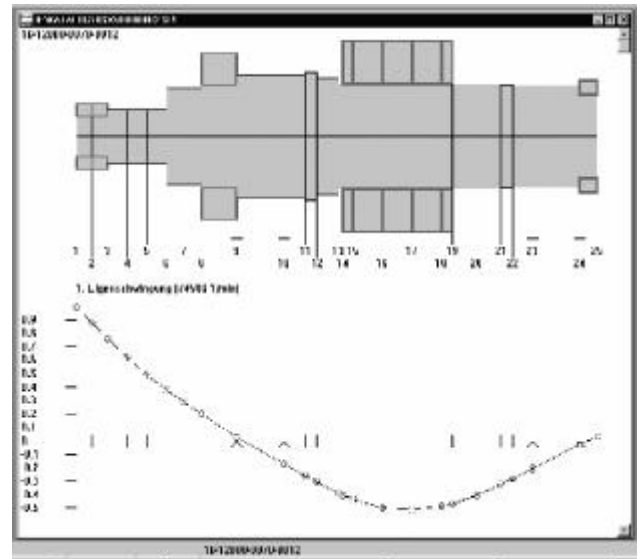

Centrifugal Forces acting on Tools

Centrifugal forces created by high rotating speed not only act as unbalancing forces but also induce stress into the tool.

Insert type milling cutters are the worst case scenario, with the weakening of the screws or clamps, the carbide inserts can become projectiles.

Vibration monitoring

Vibration monitoring equipment can less the risk of damage to both the spindle and machine, and also help prevent personnel injury by early detection of wear and looseness in both the spindle and tooling.

When selecting and installing monitoring equipment it should be noted that vibration from the machine and related components must be filtered out or ignored, so as to prevent unnecessary shut down of the machine.

1 mm = 0.03937 in.

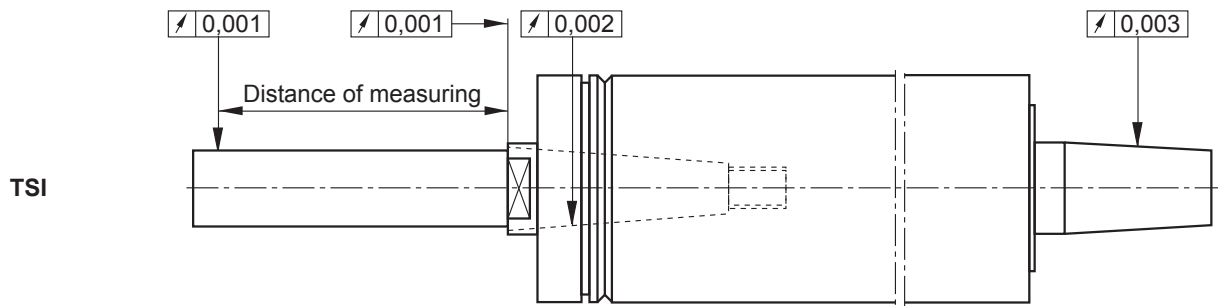
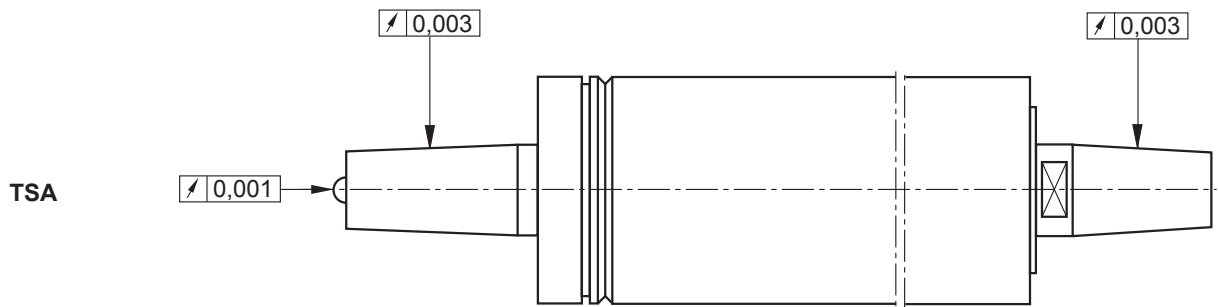
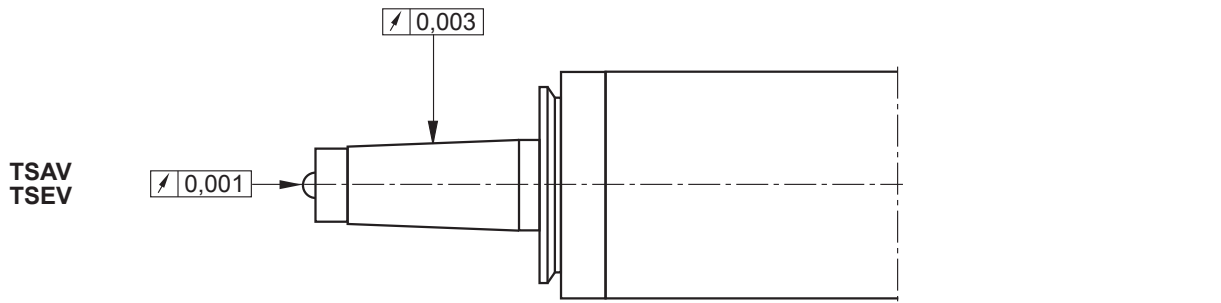

Distance of measuring: five times taper dia. (k_1) max. 100 mm (3.937 inch)

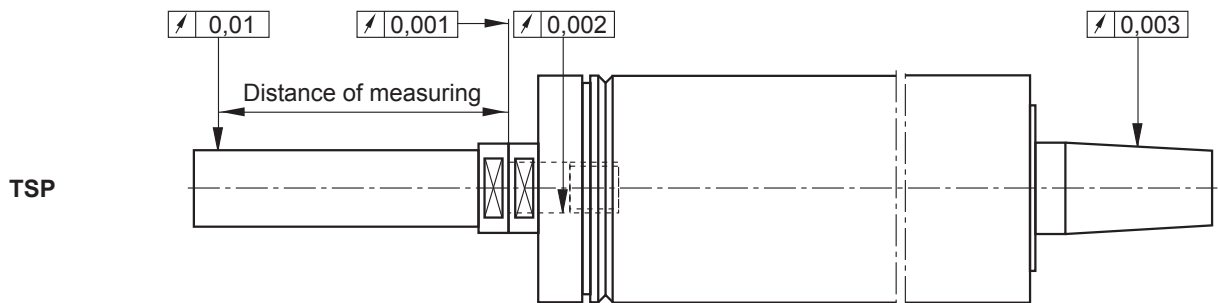

Distance of measuring: five times taper dia. (d) max. 100 mm (3.937 inch)

Spindles with increased radial and axial runout on request.