A Die Sets

Cast Iron, Steel and Aluminium
Die Set Press Units, Lamination Die Set Units, Tooling Pallet Die Sets

B Precision Ground Plates and Flat Bars

C Lifting and Clamping Devices

D Guide Elements

E Ground Precision Components

F Springs

G Elastomer-Bars, -Sheets, -Sections

H FIBRO Chemical Tooling Aids

J Peripheral Equipment

K Cam Units

L Standard Parts for Mould Making



Cast Iron-, All-Steel- and Aluminium Die Sets

Execution

Contour faces of FIBRO Steel Die Sets are fully machined. Contour faces of Aluminium Die Sets are sawn, as are those of Aluminium Plates. However, these contour faces can also be machined on request. To all die set plates, a general thickness tolerance of ± 2 mm applies.

Guide Elements

Guide pillars DIN 9825/ISO 9182 (209.19.) and headed guide bushes DIN 9831/ISO 9448 (2081.) are normal equipment on all-steel die sets.

Detailed information under Guide Elements.

Lifting Aids on Die Sets

Plate sizes with edges $a_1+b_1 \geq 1000$ mm, and die sets weighting more than 100 kg, are fitted with threaded holes for two lifter eyebolts per plate. Eyebolts etc. are supplied against special order.

**Special Die Sets and Plates to
Customers' Drawings**

Die sets and plates up to size 2200×1100 mm (external dims.) will be made to customer's drawings, with any special features and highest precision.

Special Machining Features

Wherever possible, all larger apertures or holes should be done by FIBRO before final machining of die sets, for their application at the customer's works must result in die set distortion and impairment of accuracy.

**Enquiry Forms for Special
Die Sets – also refer to pages
A30 – A33**

Special pre-printed forms for enquiries and ordering are available on request. All the customer has to do is the filling-in of dimensions and the specifying of guide elements or special machining features where applicable.

Contents

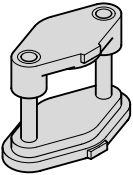
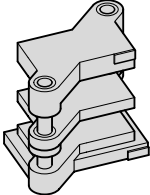
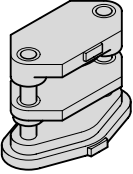
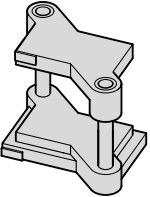
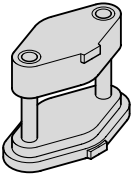
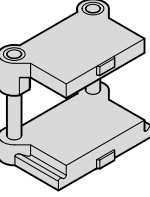
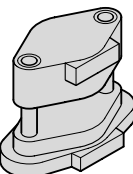
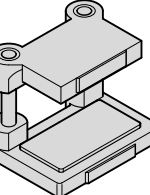
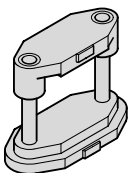
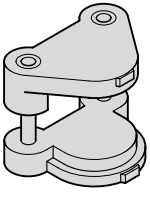
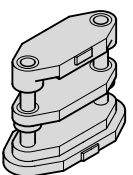
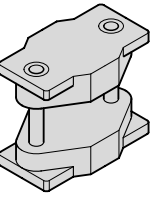
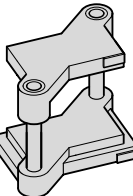
		Page		Page
Notes on Sliding Guides and Ball Bearing Guides		A7		
Cast Iron Die Sets		A9–A22		
	201.01.	A10		201.23. A17
	201.03.	A11		201.26. A18
	201.05.	A12		201.31. A19
	201.07.	A13		201.33. A20
	201.11.	A14		201.36. A21
	201.13.	A15		201.39. A22
	201.21.	A16		

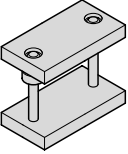
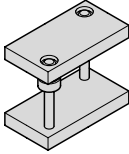
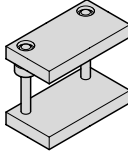
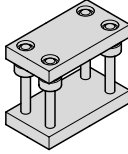
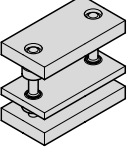
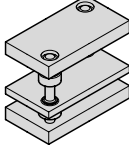
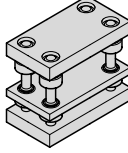
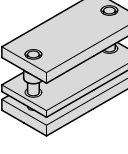
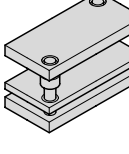
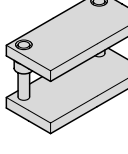
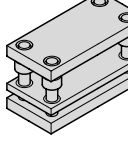
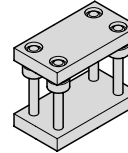
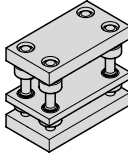
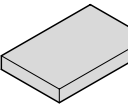
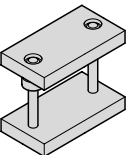
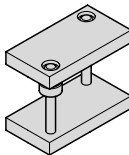
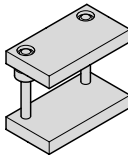
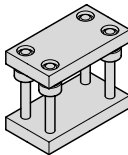
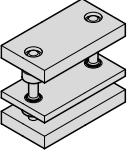
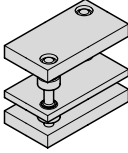
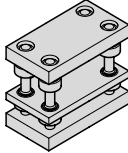
				Page				
All Steel- and Aluminium Die Sets				A23–A41				
Standard All-Steel Die Sets – without stripper plates				A24–A28				
	2010.45.		2010.46.		2010.47.		2010.49.	
Standard All-Steel Die Sets – with stripper plates				A25–A29				
	2010.45.		2010.46.				2010.49.	
Ordering Forms: All-Steel Die Sets to Customers' Specifications – with or without stripper plates				A30–A33				
	201.45. 201.65.		201.46. 201.66.		201.47. 201.67.		201.49. 201.69.	
Die Sets ECO-LINE without / with stripper plates				A34–A35				
	2010.55 ... 894 2010.57 ... 894 2010.59 ... 894				2010.55 ... 895 2010.57 ... 895 2010.59 ... 895			
Steel- and Aluminium Plates				A36–A37				
	2900. 2910.							
Standard Aluminium Die Sets – without stripper plates				A38–A42				
	2010.65.		2010.66.		2010.67.		2010.69.	
Standard Aluminium Die Sets – with stripper plates				A39–A43				
	2010.65.		2010.66.				2010.69.	

Contents

Page

Die Set Press Units

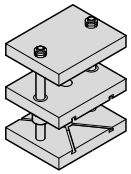

2011.45.

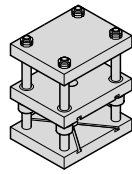

2011.49

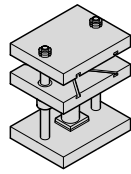

201.145.

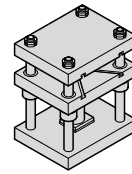

201.149.

A44–A46

Special Die Sets (All-Steel)
to Customers' Specifications

A47–A50

FIBRO Progression/
Lamination Die Sets Units

A51–A57

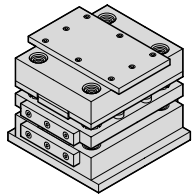

201.50.

FIBRO Tooling Pallet Die Sets for fast exchange of pallet-born press tooling sets

A59–A65

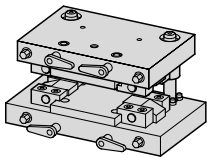

201.95.

FIBRO Precision Sliding Guides – Carbonitrided Sintered Ferrite Bushes

These guides employ bushes made from sintered ferrite of high purity with carbonitrided surface. Bearing surfaces are fine-ground.

The sintered ferrite has a porosity content of 18–20 % by volume, vacuum filled with special lubricant FIBROLIT LD. As additional long term lubrication it is recommended to fill up the groove in the bushing with FIBROLIT LD 280.34 – see page H 14. Even under arduous running conditions, this material can be relied upon for good protection against oil film rupture.

Under no circumstances must molybdenum disulfite be added to the lubricant.

For bearing clearance ranges – see page D11.

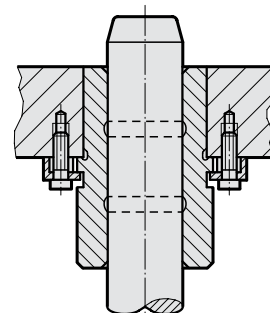

FIBRO Precision Sliding Guides, bronze-coated

consists of a steel body with bronze-coated running surface with helical oil groove and a grease nipple for lubrication.

The steel body guarantees excellent resistance to breaking, even when subject to high loading at the edges.

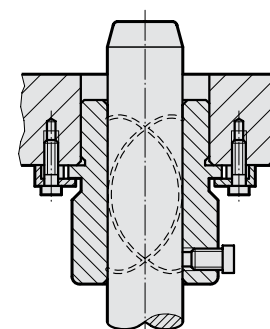

FIBRO High Precision Ball Bearing Guides

Careful manufacture at narrowest tolerances, and exactly the right amount of preloading* result in a play-free guide element of exceptional performance potential.

Our superfinished running surfaces further enhance the advantages of ball bearing guides.

Toolmakers favour ball bearing guides because of their free movement on the bench.

FIBRO ball bearing guides have brass ball cages – a material giving optimum results in stability and ball density.

Despite their unquestionable reliability at high speeds in particular, ball bearing guides with their point contact of the balls remain somewhat sensitive to shock and sustained radial loads. To some extent, generous dimensioning of pillar diameters helps to compensate for this inherent disadvantage.

* Average preloading:

- 4 μm on pillars from 8 to 12 mm diameter
- 7– 9 μm on pillars from 15 to 16 mm diameter
- 9–11 μm on pillars from 18 to 42 mm diameter
- 11–13 μm on pillars from 50 to 80 mm diameter

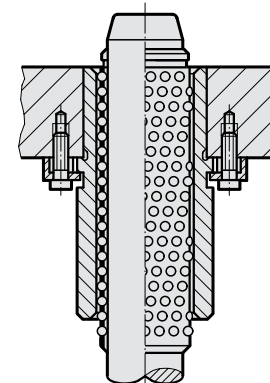

FIBRO Precision Roller Guides

In comparison to ball bearing guides, FIBRO Roller Guide Elements have considerably higher capacities for radial loads.

The much larger contact area of the rollers permits a significant reduction in preload values. This affords a longer service life of the units.

The following preload values apply to FIBRO Roller Guides:

For static loads/low velocities

- pillar diameters up to $\text{Ø } 25/32$ = 2,5 μm
- $\text{Ø } 30/32$ = 3 μm
- $\text{Ø } 40-50$ = 3,5 μm
- $\text{Ø } 63$ = 4 μm

For Dynamic Loads/High Velocities

- pillar diameters up to $\text{Ø } 25/32$ = 1,5 μm
- $\text{Ø } 30/32$ = 2 μm
- $\text{Ø } 40-50$ = 2,5 μm
- $\text{Ø } 63$ = 3 μm

Use only pairing class

- guide pillar red = .30
- guide bush yellow = .10

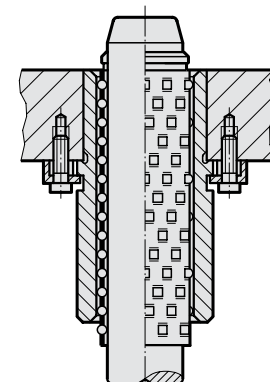

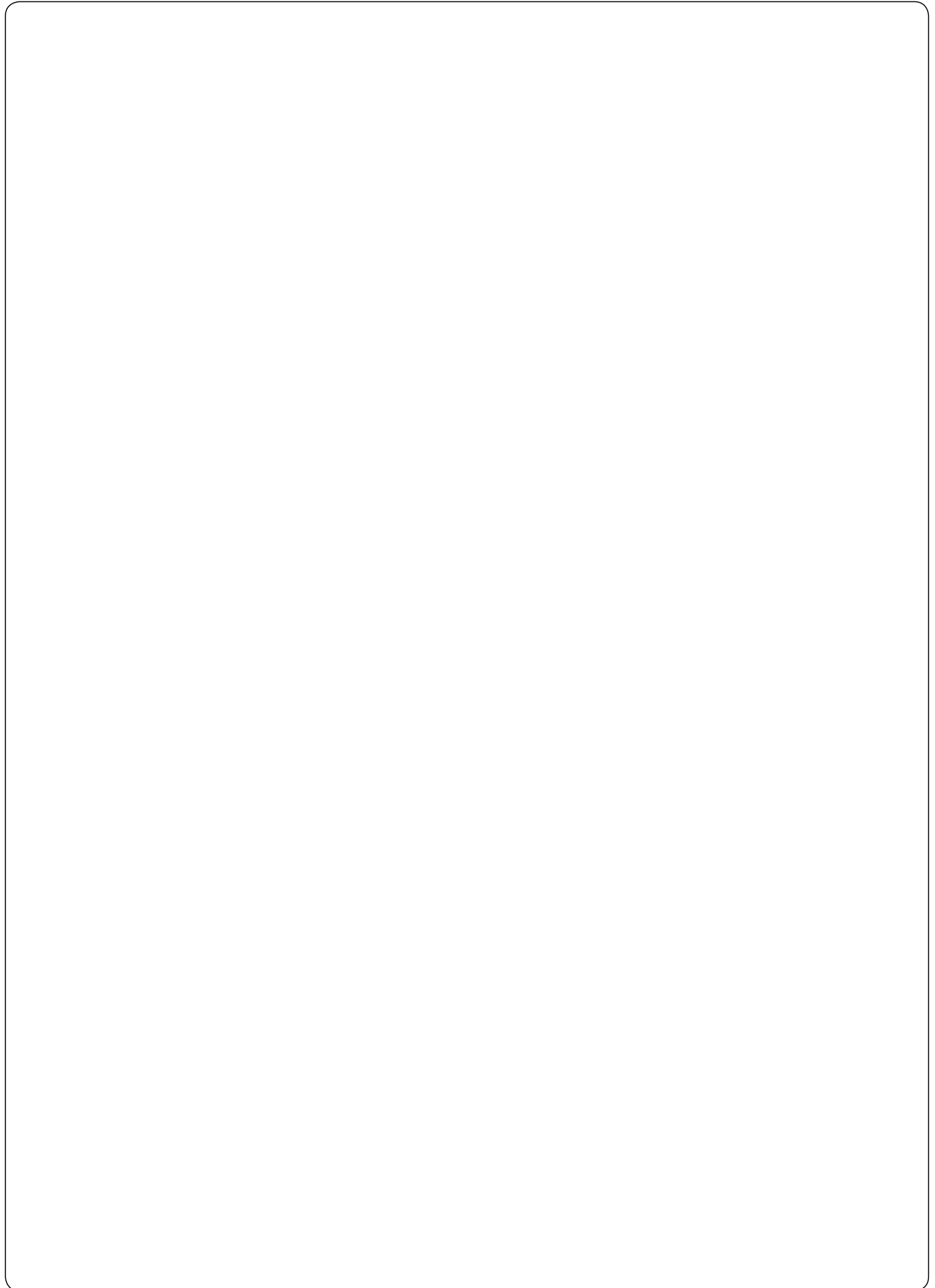

Cast Iron Die Sets

Die Sets DIN 9812 Shape D and DG

201.01.



201.01.

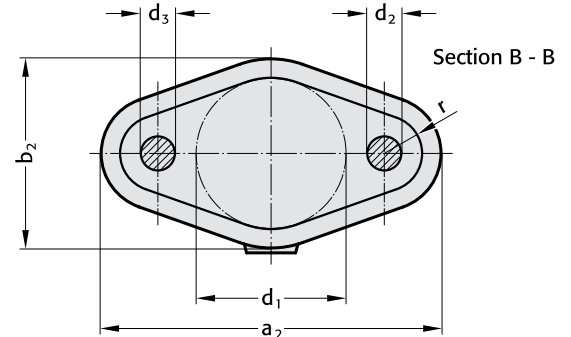
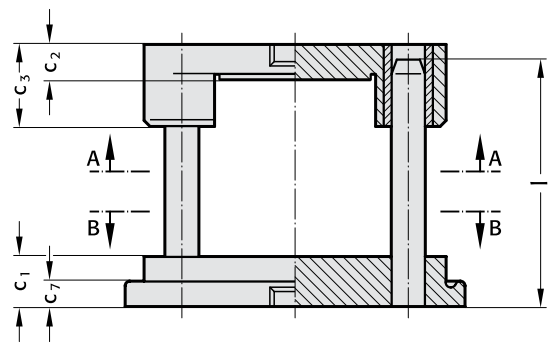
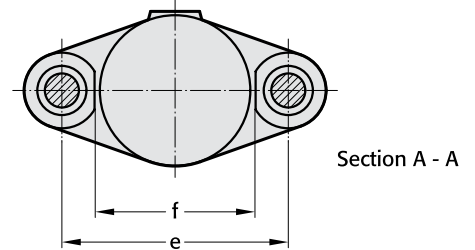

Guide Elements

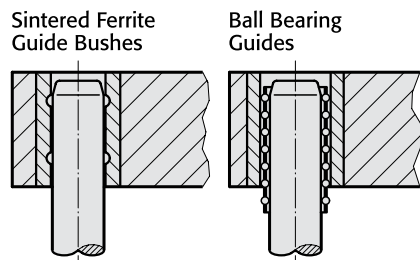

Order No (part II)
Available with or without shank thread in top bolster

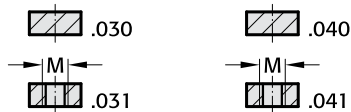

201.01.

Order No	Work area													
Part I	d ₁	a ₂	b ₂	c ₁	c ₂	c ₃	c ₇	d ₂	d ₃	e	f	l	r	M
201.01.063	63	182	100	40	25	60	20	16	15	106	73	140	20	16x1,5
080	80	236	120	50	30	80	30	20	19	140	90	160	28	20x1,5
100	100	275	140	50	30	80	30	25	24	165	110	160	35	20x1,5
125	125	300	165	50	30	80	30	25	24	190	139	160	35	20x1,5
160	160	360	200	56	40	90	30	32	30	240	174	180	40	24x1,5
180	180	380	220	56	40	90	30	32	30	260	194	180	40	24x1,5
200	200	400	240	56	40	90	30	32	30	280	218	180	40	24x1,5
250	250	496	300	56	50	100	30	40	38	350	268	200	48	30x2
315	315	563	365	63	50	100	30	40	38	417	333	224	48	30x2

Ordering Code (example):

Die set = 201.01.
 Work area 160 mm = 160.
 Guide type sintered ferrite = 03
 Shank thread without = 0
 Order No = 201.01.160.030

201.03.

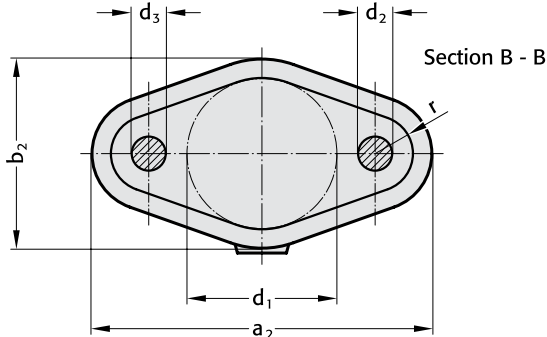
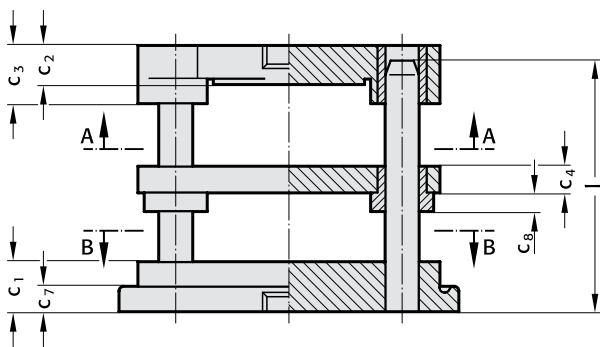
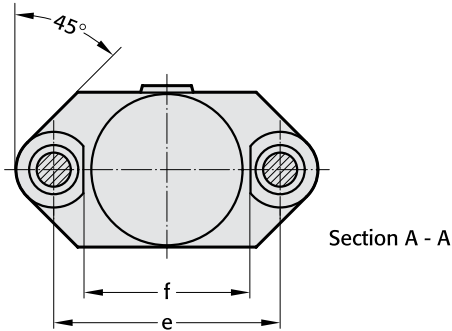

Guide Elements

Sintered Ferrite Guide Bushes

Ball Bearing Guides

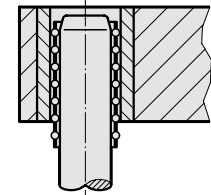
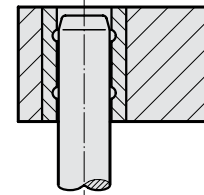

Steel

Steel

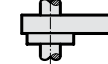

Stripper

Order No (part II):
Available with or
without shank thread
in top bolster

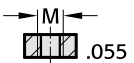
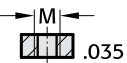

201.03.

Order No Part I	work area															
	d ₁	a ₂	b ₂	c ₁	c ₂	c ₃	c ₄	c ₇	c ₈	d ₂	d ₃	e	f	l	r	M
201.03.100	100	275	140	50	30	50	22	30	18	25	24	165	119	160	35	20x1,5
125	125	300	165	50	30	50	22	30	18	25	24	190	144	160	35	20x1,5
160	160	360	200	56	40	60	27	30	18	32	30	240	184	180	40	24x1,5

Ordering Code (example):

Die set	=	201.03.
Work area	125 mm	= 125.
Guide type	sintered ferrite	= 03
Shank thread	without	= 4
Order No	=	201.03.125.034

Die Sets DIN 9816 Shape D

201.05.



201.05.

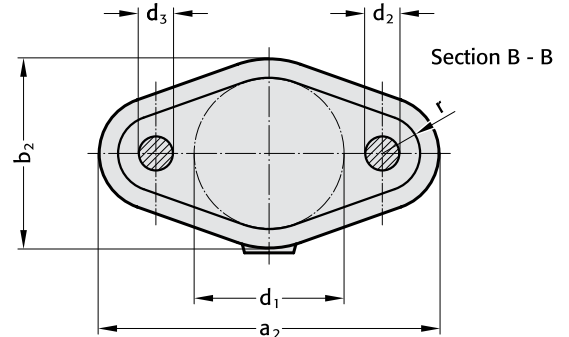
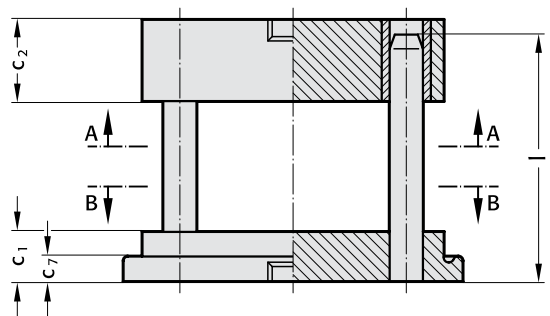
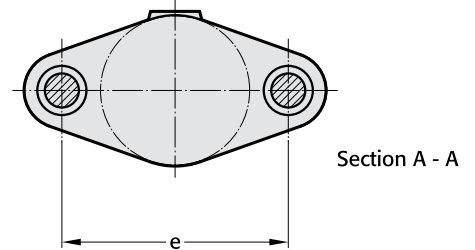

Guide Elements

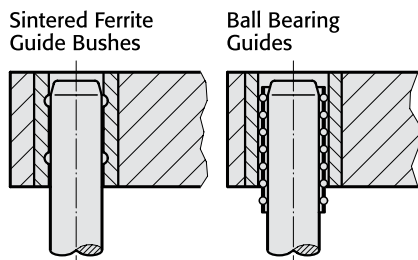

Order No (part II):
Without shank thread in top bolster



201.05.

Order No	work area										
Part I	d ₁	a ₂	b ₂	c ₁	c ₂	c ₇	d ₂	d ₃	e	l	r
201.05.063	63	182	100	40	65	20	16	15	106	140	20
080	80	236	120	50	70	30	20	19	140	160	28
100	100	275	140	50	75	30	25	24	165	180	35
125	125	300	165	50	80	30	25	24	190	180	35
160	160	360	200	56	90	30	32	30	240	224	40
200	200	400	240	56	100	30	32	30	280	224	40

Ordering Code (example):

Die set = 201.05.
 Work area 100 mm = 100.
 Guide Type sintered ferrite = 030
 Order No = 201.05.100.030

FIBRO

201.07.

Die Sets similar to DIN 9816 Shape D

201.07.

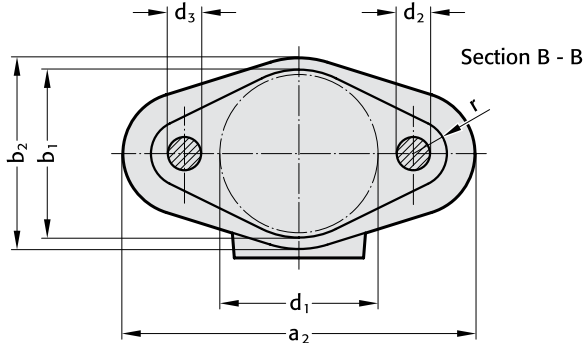
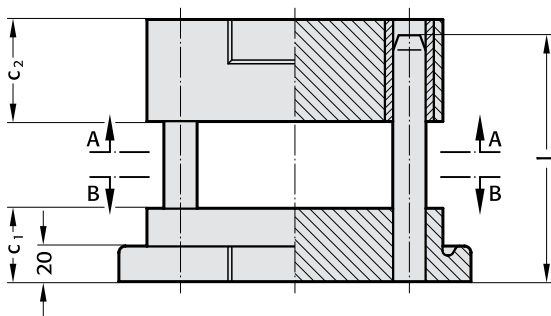
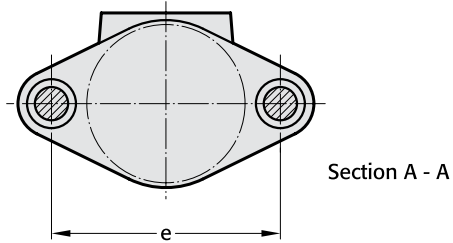

Guide Elements

Sintered Ferrite
Guide Bushes

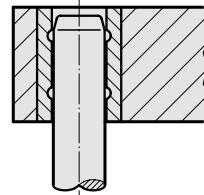

Order No (part II):
Without shank thread in top bolster



201.07.

Order No

work area

Part I	d ₁	a ₂	b ₁	b ₂	c ₁	c ₂	d ₂	d ₃	e	l	r
201.07.040.030	40	112	45	55	36	40	16	15	66	100	13
063.030	63	142	68	78	40	55	16	15	90	125	14

Ordering Code (example):

Die set = 201.07.
Work area 40 mm = 040.
Guide Type sintered ferrite = 030
Order No = 201.07.040.030

Die Sets DIN 9812 Shape C and CG

201.11.



201.11.

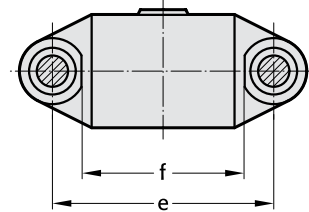

Section A - A

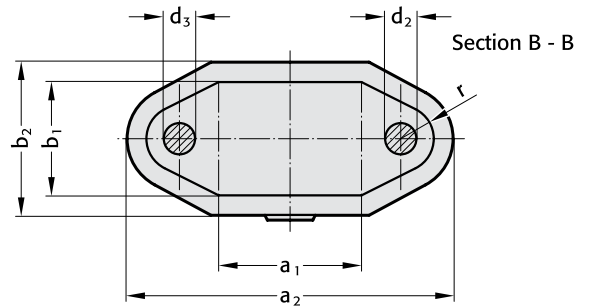
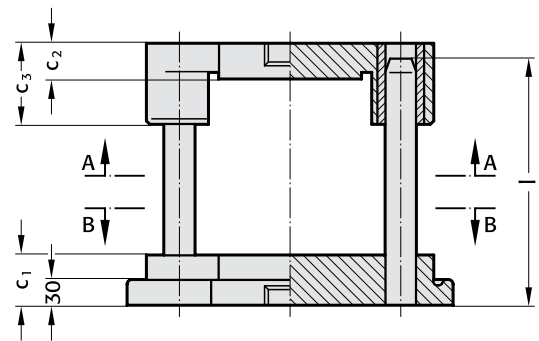

Section B - B

Guide Elements

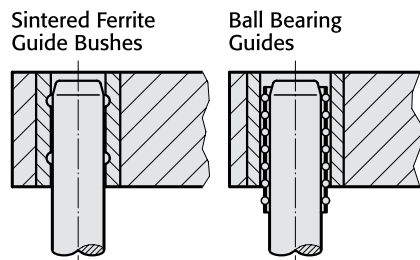

Order No (part II):
Available with or without shank thread in top bolster

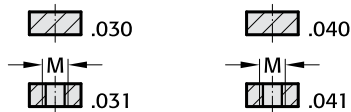

201.11.

Order No	work area	a ₂	b ₂	c ₁	c ₂	c ₃	d ₂	d ₃	e	f	l	r	M
201.11.070.050	70 x 50	170	70	40	22	50	20	19	110	73	140	20	20x1,5
080.063	80 x 63	235	103	50	30	80	20	19	140	90	160	27	20x1,5
100.063	100 x 63	253	103	50	30	80	20	19	158	110	160	27	20x1,5
080	100 x 80	265	120	50	30	80	25	24	165	110	160	30	20x1,5
201.11.125.080	125 x 80	290	120	50	30	80	25	24	190	139	160	30	20x1,5
160.080	160 x 80	325	120	50	30	80	25	24	225	174	160	30	20x1,5
200.080	200 x 80	365	120	50	30	80	25	24	265	218	160	30	20x1,5
125.100	125 x 100	290	140	50	40	90	25	24	190	139	160	30	24x1,5
160.100	160 x 100	325	140	50	40	90	25	24	225	174	160	30	24x1,5
200.100	200 x 100	395	140	56	40	90	32	30	280	218	180	37	24x1,5
160.125	160 x 125	355	165	56	40	90	32	30	240	174	180	37	24x1,5
200.125	200 x 125	395	165	56	40	90	32	30	280	218	180	37	24x1,5
250.125	250 x 125	445	165	56	40	90	32	30	330	268	180	37	24x1,5
315.125	315 x 125	510	165	56	40	90	32	30	395	333	180	37	24x1,5
200.160	200 x 160	395	200	56	50	100	32	30	280	218	200	37	30x2
250.160	250 x 160	445	200	56	50	100	32	30	330	268	200	37	30x2
200	250 x 200	496	250	63	50	100	40	38	350	268	224	48	30x2
201.11.315.200	315 x 200	563	250	63	50	100	40	38	417	333	224	48	30x2
250	315 x 250	563	300	63	50	100	40	38	417	333	224	48	30x2

201.13.

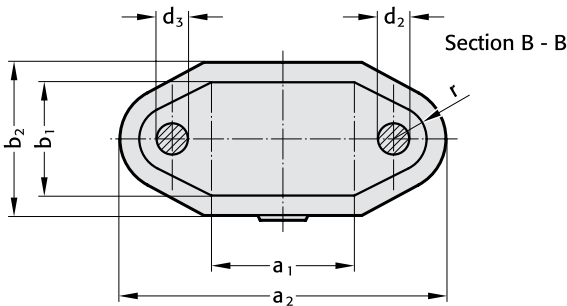
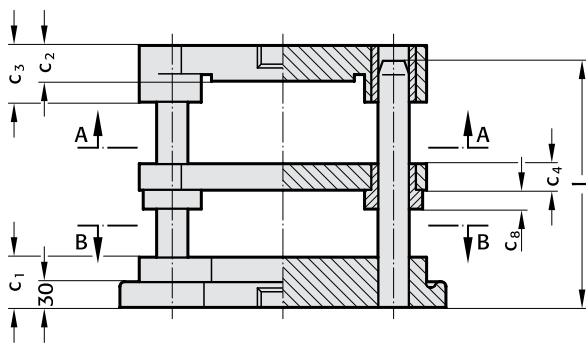
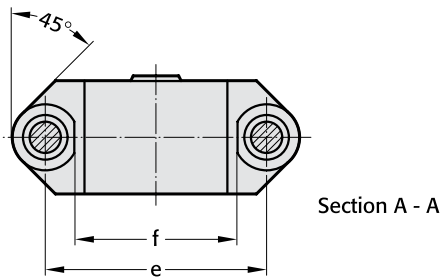

Guide Elements

Sintered Ferrite Guide Bushes

Ball Bearing Guides

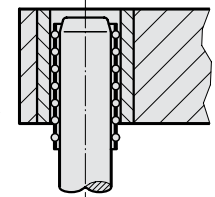
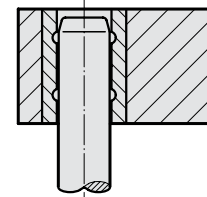

Stripper

Steel

Steel

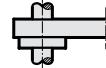
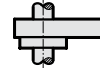

Order No (part II):
Available with or
without shank thread
in top bolster

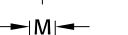
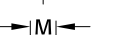

201.13.

Order No	work area	a ₂	b ₂	c ₁	c ₂	c ₃	c ₄	c ₈	d ₂	d ₃	e	f	l	r	M
201.13.080.063	80 x 63	235	103	50	30	50	18	14	20	19	140	104	160	27	20x1,5
100.080	100 x 80	265	120	50	30	50	22	18	25	24	165	119	160	30	20x1,5
125.100	125 x 100	290	140	50	40	60	22	18	25	24	190	144	160	30	24x1,5
160.125	160 x 125	355	165	56	40	60	27	18	32	30	240	184	180	37	24x1,5
200.160	200 x 160	395	200	56	50	70	27	18	32	30	280	224	200	37	30x2

Ordering Code (example):

Die set		=	201.13.
Work area length	125 mm	=	125.
Work area width	100 mm	=	100.
Guide type	sintered ferrite	=	03
shank thread	without	=	4
Order No		=	201.13.125.100.034

Die Sets DIN 9819 Shape C and CG

201.21.



201.21.

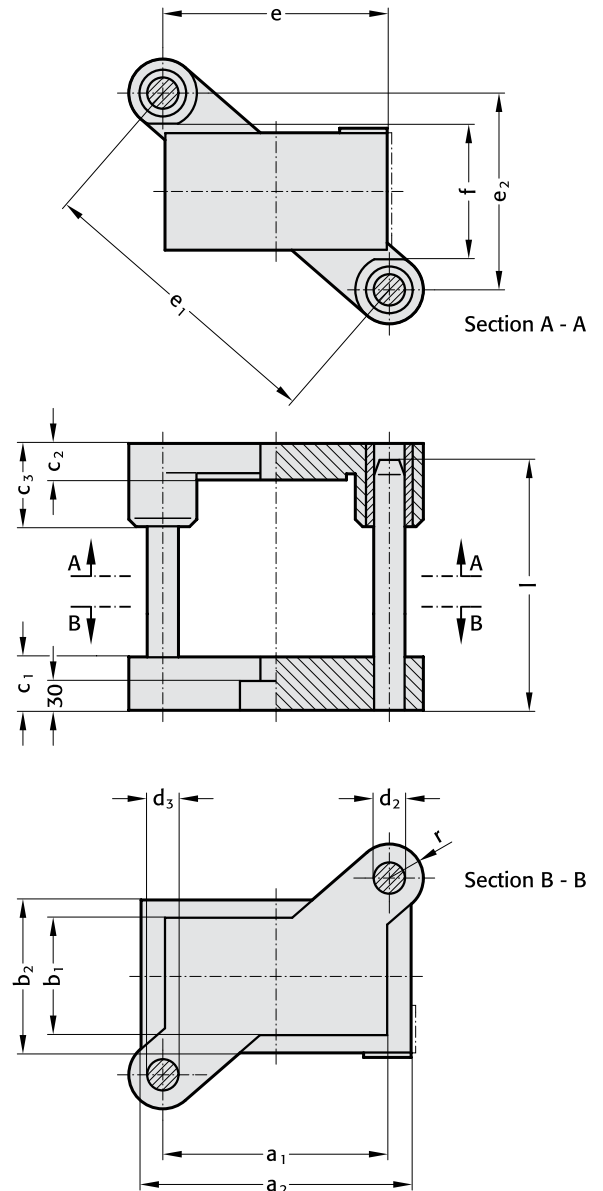

Guide Elements

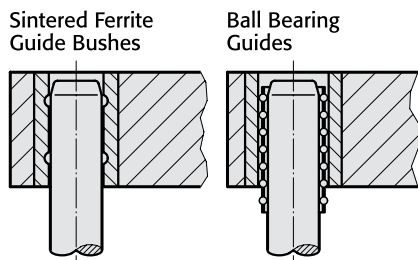

Order No (part II):
Available with or without shank thread in top bolster

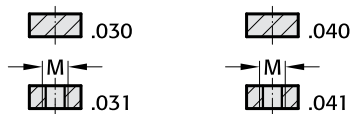

201.21.

Order No	work area	a ₂	b ₂	c ₁	c ₂	c ₃	d ₂	d ₃	e	e ₁	e ₂	f	l	r	M
201.21.080.063	80 x 63	120	103	50	30	80	20	19	80	145	121	73	160	27	20x1,5
100.063	100 x 63	140	103	50	30	80	20	19	100	157	121	73	160	27	20x1,5
080	100 x 80	140	120	50	30	80	25	24	100	175	144	90	160	30	20x1,5
201.21.125.080	125 x 80	165	120	50	30	80	25	24	125	191	144	90	160	30	20x1,5
100	125 x 100	165	140	50	40	90	25	24	125	206	164	110	160	30	24x1,5
201.21.160.100	160 x 100	200	140	50	40	90	25	24	160	229	164	110	160	30	24x1,5
200.100	200 x 100	240	140	56	40	90	32	30	200	268	179	110	180	37	24x1,5
160.125	160 x 125	200	165	56	40	90	32	30	160	259	204	139	180	37	24x1,5
200.125	200 x 125	240	165	56	40	90	32	30	200	286	204	139	180	37	24x1,5
250.125	250 x 125	290	165	56	40	90	32	30	250	323	204	139	180	37	24x1,5
315.125	315 x 125	355	165	56	40	90	32	30	315	375	204	139	180	37	24x1,5
200.160	200 x 160	240	200	56	50	100	32	30	200	312	240	174	200	37	30x2
250.160	250 x 160	290	200	56	50	100	32	30	250	346	240	174	200	37	30x2
200	250 x 200	300	250	63	50	100	40	38	250	392	302	218	224	48	30x2
201.21.315.200	315 x 200	365	250	63	50	100	40	38	315	436	302	218	224	48	30x2
250	315 x 250	365	300	63	50	100	40	38	315	472	352	268	224	48	30x2

201.23.

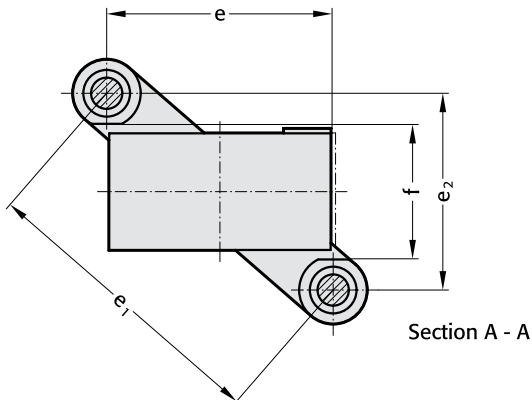

Section A - A

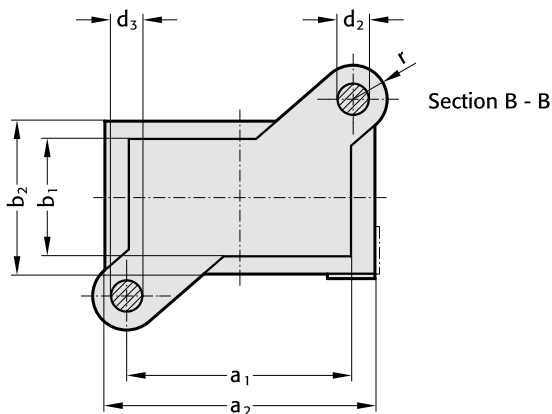
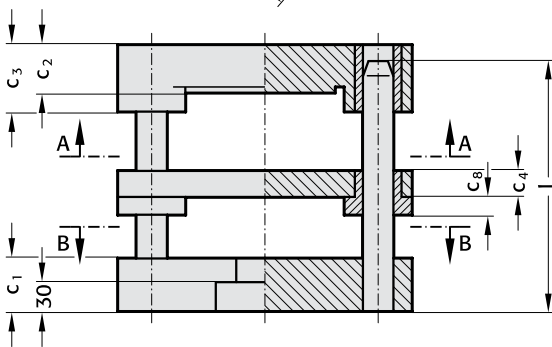

Section B - B

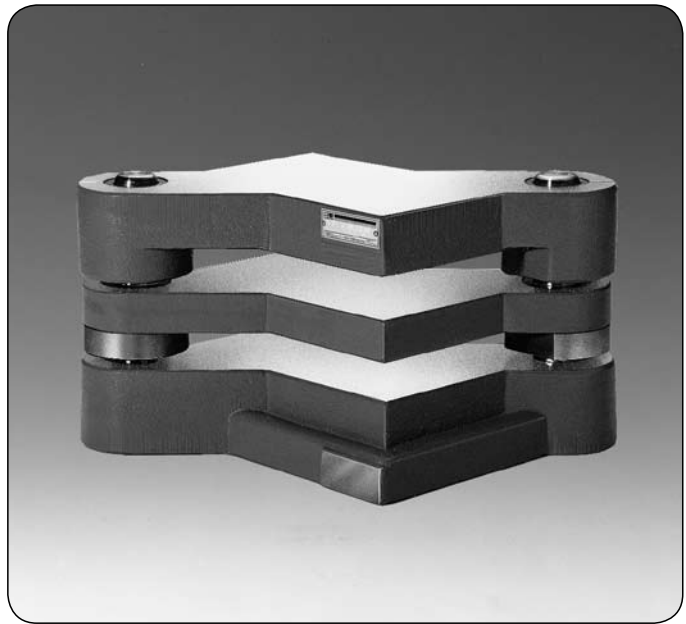

Guide Elements

Sintered Ferrite Guide Bushes

Ball Bearing Guides

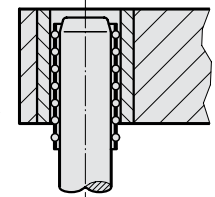
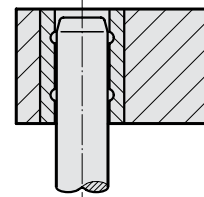

Stripper

Steel

Steel

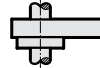
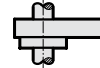

Order No (part II):
Available with or
without shank thread
in top bolster

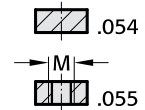
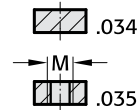

201.23.

Order No	work area	a ₂	b ₂	c ₁	c ₂	c ₃	c ₄	c ₈	d ₂	d ₃	e	e ₁	e ₂	f	l	r	M
201.23.100.080	100 x 80	140	120	50	30	50	22	18	25	24	100	175	144	98	160	30	20x1,5
125.100	125 x 100	165	140	50	40	60	22	18	25	24	125	206	164	118	160	30	24x1,5
160.100	160 x 100	200	140	50	40	60	22	18	25	24	160	229	164	118	160	30	24x1,5
125	160 x 125	200	165	56	40	60	27	18	32	30	160	259	204	148	180	37	24x1,5
201.23.200.125	200 x 125	240	165	56	40	60	27	18	32	30	200	286	204	148	180	37	24x1,5
250.160	250 x 160	290	200	56	50	70	27	18	32	30	250	346	240	184	200	37	30x2

Ordering Code (example):

Die set		= 201.23.
Work area length	160 mm	= 160.
Work area width	100 mm	= 100.
Guide type	sintered ferrite	= 03
Shank thread	without	= 4
Order No		= 201.23.160.100.034



201.26.

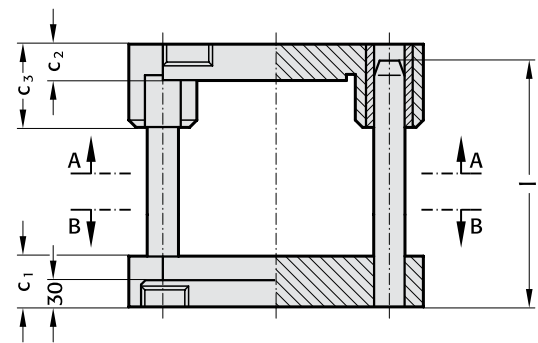
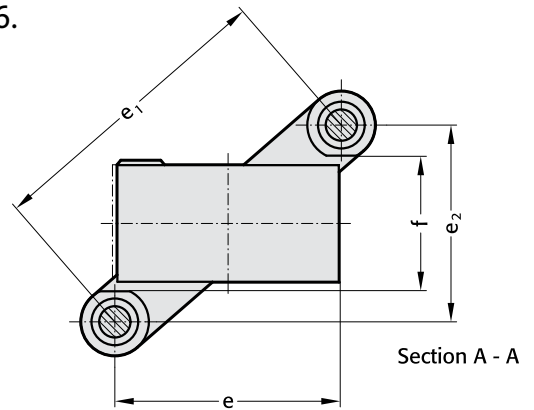

Guide Elements

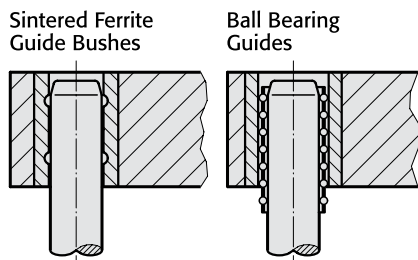

Order No (part II):
Available with or without shank thread in top bolster

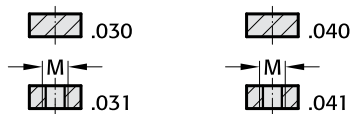

201.26.

Order No	work area	a ₂	b ₂	c ₁	c ₂	c ₃	d ₂	d ₃	e	e ₁	e ₂	f	l	r	M
Part I	a ₁ x b ₁														
201.26.125.100.030	125 x 100	165	140	50	40	90	25	24	125	206	164	110	160	30	24x1,5
160.100.030	160 x 100	200	140	50	40	90	25	24	160	229	164	110	160	30	24x1,5
125.030	160 x 125	200	165	56	40	90	32	30	160	259	204	139	180	37	24x1,5
201.26.200.125.030	200 x 125	240	165	56	40	90	32	30	200	286	204	139	180	37	24x1,5
160.030	200 x 160	240	200	56	50	100	32	30	200	312	240	174	200	37	30x2

Ordering Code (example):

Die set		=	201.26.
Work area length	160 mm	=	160.
Work area width	125 mm	=	125.
Guide type	sintered ferrite	=	03
Shank thread	without	=	0
Order No		=	201.26.160.125.030

201.31.

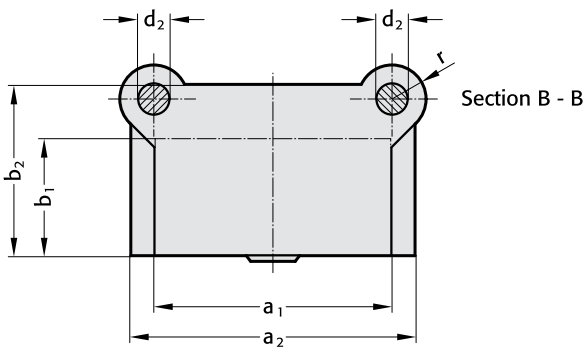
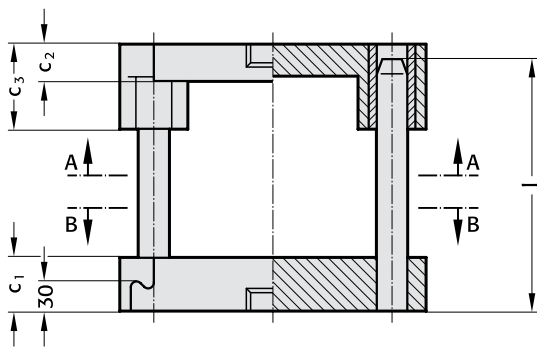
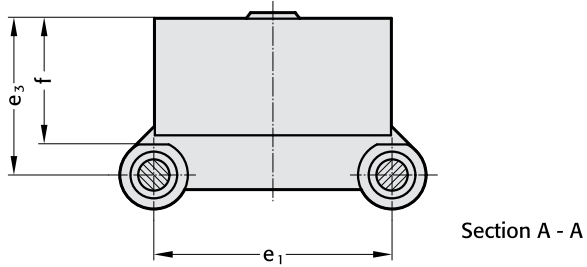

Guide Elements

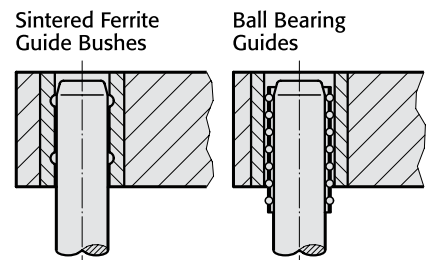

Order No (part II):
Without shank thread in top bolster



201.31.

Order No	work area	a ₂	b ₂	c ₁	c ₂	c ₃	d ₂	e ₁	e ₃	f	l	r
Part I	a ₁ x b ₁											
201.31.063.050	63 x 50	95	84	40	25	50	20	72	77	55	140	22
080.063	80 x 63	125	105	45	30	60	20	80	92	68	160	27
100.063	100 x 63	145	105	45	30	60	20	100	92	68	160	27
080	100 x 80	145	130	50	30	70	25	100	112	87	160	30
201.31.125.080	125 x 80	170	130	50	30	70	25	125	112	87	160	30
160.080	160 x 80	205	130	50	30	70	25	160	112	87	160	30
125.100	125 x 100	170	150	56	40	90	32	125	140	107	180	37
160.100	160 x 100	205	150	56	40	90	32	160	140	107	180	37
200.100	200 x 100	245	150	56	40	90	32	200	140	107	180	37
160.125	160 x 125	215	180	56	40	90	32	160	165	132	180	37
200.125	200 x 125	255	180	56	40	90	32	200	165	132	180	37
250.125	250 x 125	305	180	56	40	90	32	250	165	132	180	37
200.160	200 x 160	255	225	63	50	90	40	200	210	167	224	48
250.160	250 x 160	305	225	63	50	120	40	250	210	167	224	48
200	250 x 200	305	270	63	50	120	50	250	260	207	224	56
201.31.315.250	315 x 250	370	320	63	50	120	50	315	310	257	224	56



201.33.

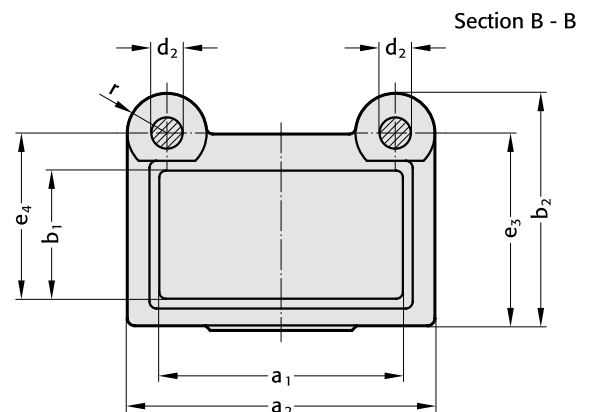
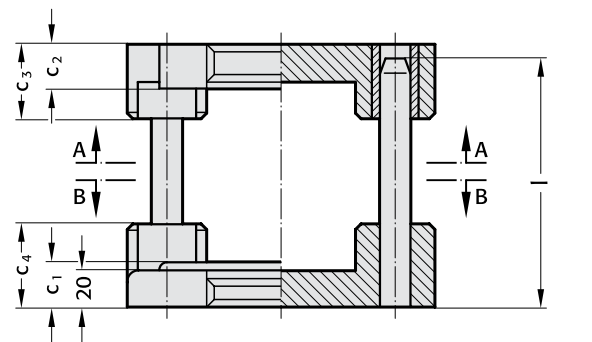
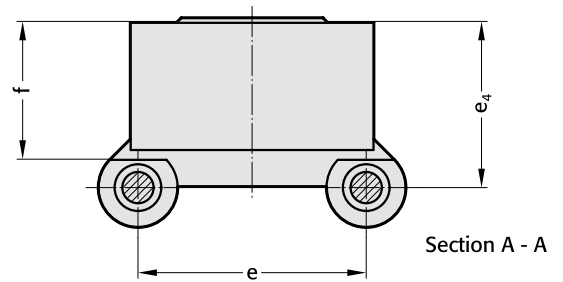

Guide Elements

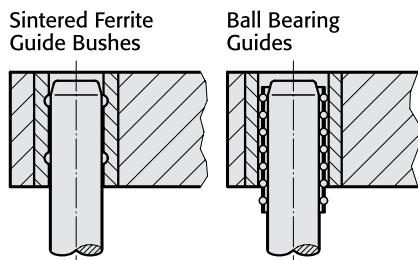

Order No (part II):
Without shank thread in top bolster



201.33.

Order No	work area	a ₂	b ₂	c ₁	c ₂	c ₃	c ₄	d ₂	e	e ₃	e ₄	f	l	r
Part I	a ₁ x b ₁													
201.33.063.050	63 x 50	116	110	25	25	40	45	16	72	88	74	57	125	22
080.060	80 x 60	116	117	25	25	40	45	20	72	95	81	62	160	22

Ordering Code (example):

Die set		=	201.33.
Work area length	63 mm	=	063.
Work area width	50 mm	=	050.
Guide type	sintered ferrite	=	030
Order No		=	201.33.063.050.030

201.36.

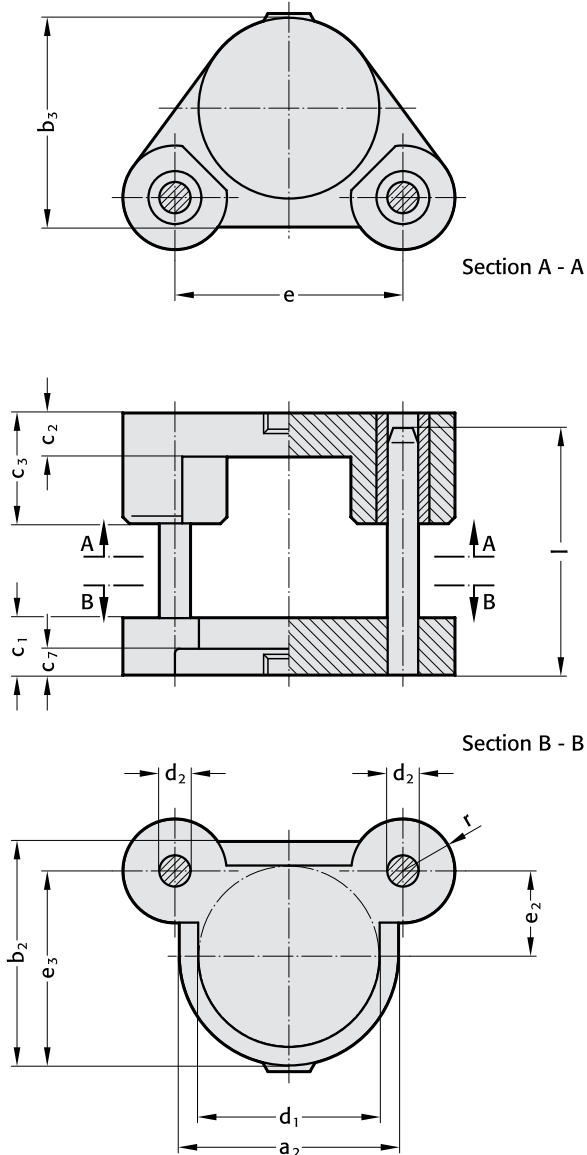

Guide Elements

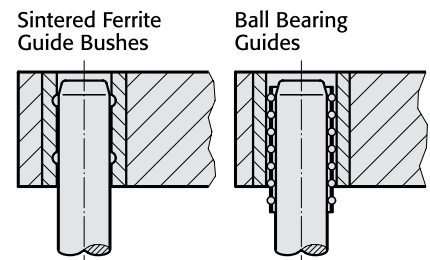

Order No (part II):
Without shank thread in top bolster



201.36.

Order No	work area														
Part I	d ₁	a ₂	b ₂	b ₃	c ₁	c ₂	c ₃	c ₇	d ₂	e	e ₂	e ₃	l	r	
201.36.050	50	80	80	65	40	30	50	25	20	66	33	73	125	20	
063	63	94	94	78	45	30	60	25	20	82	41	88	125	25	
080	80	110	110	95	50	30	70	30	25	105	52	107	160	30	
100	100	140	140	120	50	30	70	30	25	125	57	127	160	30	
125	125	166	166	145	56	40	90	30	32	157	73	156	180	38	
160	160	200	200	180	63	50	120	30	40	200	85	185	224	48	
180	180	220	220	200	63	50	120	30	40	224	90	200	224	48	
200	200	250	250	225	63	50	120	30	50	250	95	220	224	56	
250	250	300	300	275	63	50	120	30	50	300	120	270	224	56	

Ordering Code (example):

Die set = 201.36.
 Work area 125 mm = 125.
 Guide type sintered ferrite = 030
 Order No = 201.36.125.030

Fine Blanking Die Sets

201.39.

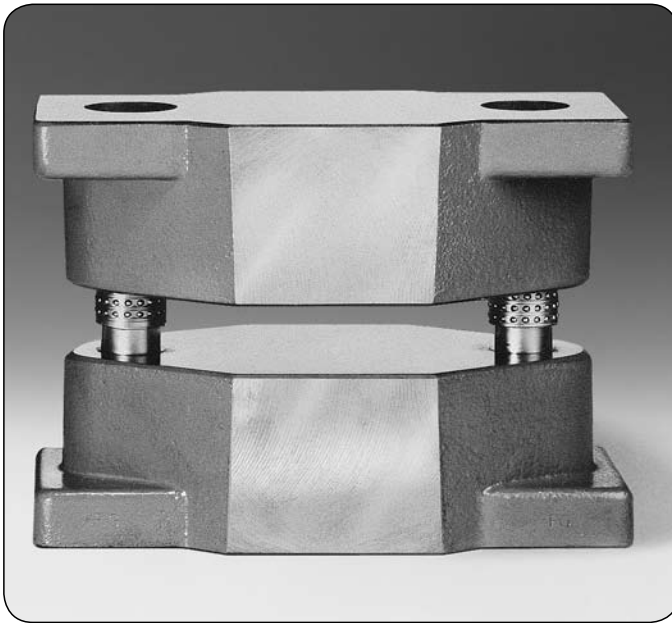

201.39.

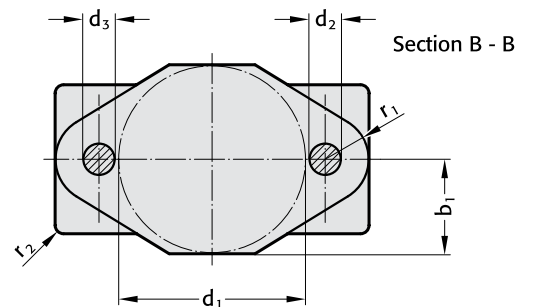
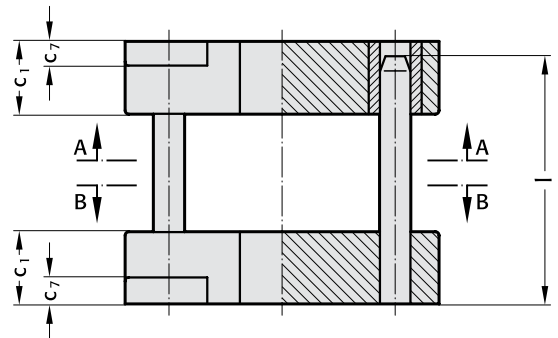
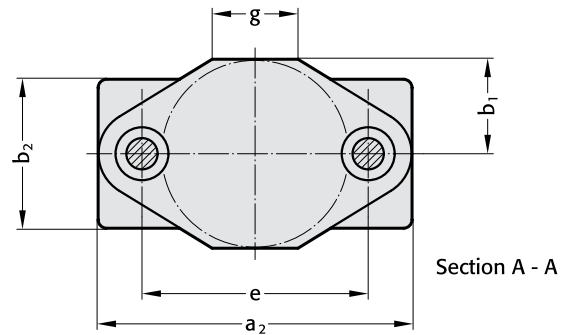

Faces front and rear fine machined after assembly – their perfect alignment permits use as datum reference.

Guide Elements

Ball Bearing Guides

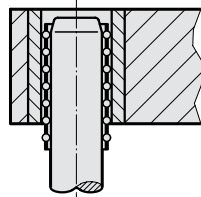

Order No (part II):
Without shank thread in top bolster

.040

201.39.

Order No	work area													
Part I	d ₁	a ₂	b ₁	b ₂	c ₁	c ₇	d ₂	d ₃	e	g	l	r ₁	r ₂	
201.39.100	100	220	50	85	75	22	25	24	140	60	140	27	6	
125	125	245	62	100	75	25	25	24	165	80	140	27	6	
160	160	290	80	140	75	25	32	30	200	80	140	35	6	
200	200	340	100	160	80	30	40	38	250	90	160	45	8	
250	250	400	125	200	85	32	40	38	300	100	180	50	10	

Ordering Code (example):

Fine Blanking Die Set = 201.39.
 Work area 160 mm = 160.
 Guide type balls = 040
 Order No = 201.39.160.040

All-Steel- and Aluminium Die Sets

FIBRO

2010.45. 2010.47.
2010.46. 2010.49.

Standard All-Steel Die Sets similar DIN 9868/ISO 11415 without stripper

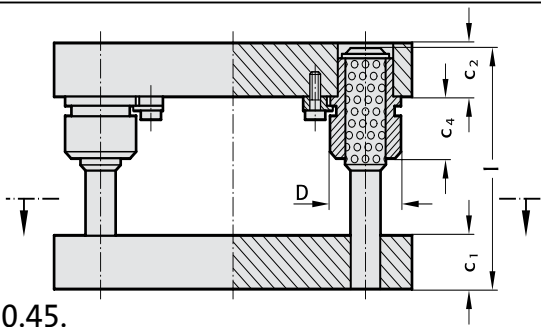

2010.45.

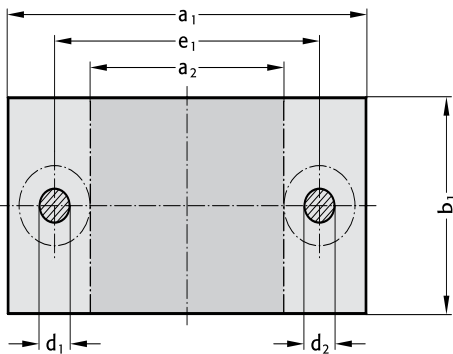

2010.46.

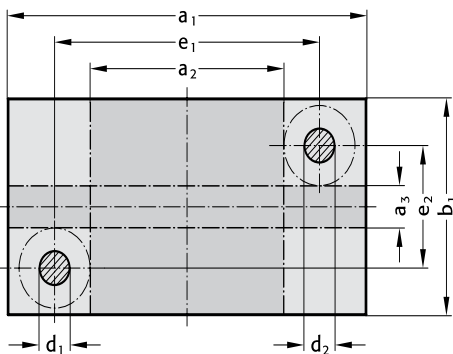

2010.47.

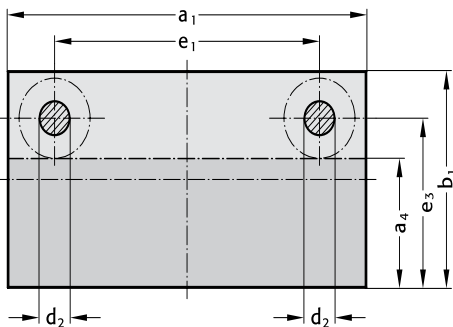

2010.49.

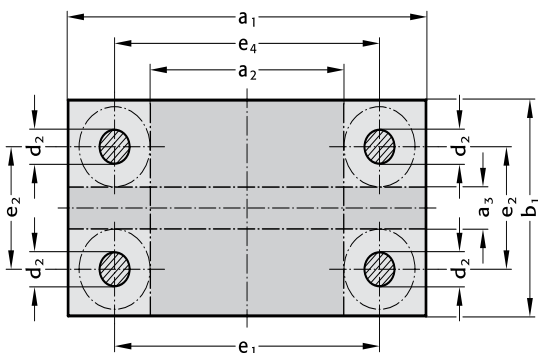

Standard Guide Systems

Headed Sintered
Ferrite Bushes,
carbonitrided

Headed Ball
Bearing Bushes

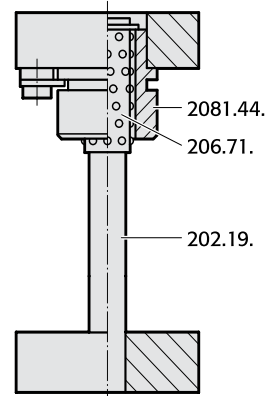
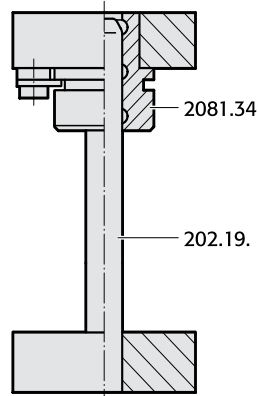

2010.□□.□□□□.□.834.

2010.□□.□□□□.□.862.

Description:

FIBRO Standard All-Steel Die Sets offer the choice between sintered ferrite sliding guides and those of the ball bearing type to DIN-ISO. Both come with headed guide bushes. These are seated in push-fit bolster bores and retained there by screw clamps.

On request, All-Steel Die Sets can also be fitted with any other FIBRO Guide Elements – for combination possibilities see page A 30.

FIBRO will furthermore supply die sets with special machining features to customers' drawings.

Execution:

External contours milled, thickness surfaces ground

a_1 or $b_1 \leq 630 = \begin{matrix} +0,4 \\ +0,2 \end{matrix}$

a_1 or $b_1 > 630 = \begin{matrix} +0,6 \\ +0,2 \end{matrix}$

Ordering example see opposite fold out page

Standard All-Steel Die Sets similar DIN 9868/ISO 11415 with stripper

FIBRO

2010.45. 2010.46.
2010.49.

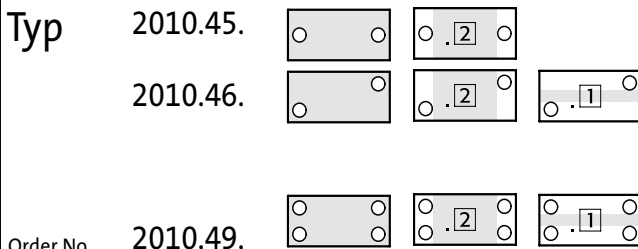

Order No 2010.49.
Part .I .II .III.IV .V

Type	Size	P.*	Guides type	ext. dims. a ₁ × b ₁	work area a ₂ × b ₁	work area a ₁ × a ₃	C ₁ ±2	C ₂ ±2	C ₃ ±2	C ₄	C ₅	d ₁ /d ₂ × l	D	e ₁	e ₂	e ₄
2010.	.1608.1.			160 × 80	60 × 80	-	32	32	25	12	12	19/20 × 180	39	100	-	-
	.1610.1.			160 × 100	60 × 100	-	32	32	25	12	12	19/20 × 180	39	100	-	-
	.1612.1.			160 × 125	60 × 125	-	32	32	25	12	12	19/20 × 180	39	100	-	-
	.1616.1.			160 × 160	60 × 160	160 × 60	32	32	25	12	12	19/20 × 180	39	100	100	103
2010.	.2010.1.			200 × 100	70 × 100	-	40	40	25	25	12	24/25 × 200	46	120	-	-
	.2010.2.						40	32								
	.2010.3.						32	40								
	.2010.4.						32	32								
2010.	.2012.1.			200 × 125	70 × 125	-	40	40	25	25	12	24/25 × 200	46	120	-	-
	.2012.2.						40	32								
	.2012.3.						32	40								
	.2012.4.						32	32								
2010.	.2016.1.			200 × 160	70 × 160	-	40	40	25	25	12	24/25 × 200	46	120	-	-
	.2016.2.						40	32								
	.2016.3.						32	40								
	.2016.4.						32	32								
2010.	.2020.1.			200 × 200	70 × 200	200 × 70	40	40	25	25	12	24/25 × 200	46	120	120	123
	.2020.2.						40	32								
	.2020.3.						32	40								
	.2020.4.						32	32								
2010.	.2512.1.			250 × 125	120 × 125	-	40	40	25	25	12	24/25 × 200	46	170	-	-
	.2512.2.						40	32								
	.2512.3.						32	40								
	.2512.4.						32	32								
2010.	.2516.1.			250 × 160	120 × 160	-	40	40	25	25	12	24/25 × 200	46	170	-	-
	.2516.2.						40	32								
	.2516.3.						32	40								
	.2516.4.						32	32								
2010.	.2520.1.			250 × 200	120 × 200	250 × 70	40	40	25	25	12	24/25 × 200	46	170	120	173
	.2520.2.						40	32								
	.2520.3.						32	40								
	.2520.4.						32	32								
2010.	.2525.1.			250 × 250	120 × 250	250 × 120	40	40	25	25	12	24/25 × 200	46	170	170	173
	.2525.2.						40	32								
	.2525.3.						32	40								
	.2525.4.						32	32								
2010.	.3116.1.			315 × 160	165 × 160	-	50	50	32	32	12	30/32 × 224	53	225	-	-
	.3116.2.						50	40								
	.3116.3.						40	50								
	.3116.4.						40	40								
2010.	.3120.1.			315 × 200	165 × 200	315 × 50	50	50	32	32	12	30/32 × 224	53	225	110	228
	.3120.2.						50	40								
	.3120.3.						40	50								
	.3120.4.						40	40								
2010.	.3125.1.			315 × 250	165 × 250	315 × 100	50	50	32	32	12	30/32 × 224	53	225	160	228
	.3125.2.						50	40								
	.3125.3.						40	50								
	.3125.4.						40	40								
2010.	.3131.1.			315 × 315	165 × 315	315 × 165	50	50	32	32	12	30/32 × 224	53	225	225	228
	.3131.2.						50	40								
	.3131.3.						40	50								
	.3131.4.						40	40								
2010.	.4020.1.			400 × 200	250 × 200	400 × 50	50	50	32	32	12	30/32 × 224	53	310	110	313
	.4020.2.						50	40								
	.4020.3.						40	50								
	.4020.4.						40	40								
2010.	.4025.1.			400 × 250	250 × 250	400 × 100	50	50	32	32	12	30/32 × 224	53	310	160	313
	.4025.2.						50	40								
	.4025.3.						40	50								
	.4025.4.						40	40								
2010.	.4031.1.			400 × 315	250 × 315	400 × 165	50	50	32	32	12	30/32 × 224	53	310	225	313
	.4031.2.						50	40								
	.4031.3.						40	50								
	.4031.4.						40	40								

Standard All-Steel Die Sets similar DIN 9868/ISO 11415 with stripper

FIBRO

2010.45. 2010.46.
2010.49.

Order No																
Part .I .II .III.IV .V																
Type	Size	P.*	Guides type	ext. dims. a ₁ × b ₁	work area a ₂ × b ₁	work area a ₁ × a ₃	c ₁ ±2	c ₂ ±2	c ₃ ±2	c ₄	c ₅	d ₁ /d ₂ × l	D	e ₁	e ₂	e ₄
2010.	.4040.1.			400 × 400	250 × 400	400 × 250	50	50	32	32	12	30/32 × 224	53	310	310	313
	.4040.2.						50	40								
	.4040.3.						40	50								
	.4040.4.						40	40								
2010.	.5025.1.			500 × 250	330 × 250	500 × 80	50	50	32	32	15	38/40 × 224	63	400	150	403
	.5025.2.						50	40								
	.5025.3.						40	50								
	.5025.4.						40	40								
2010.	.5031.1.			500 × 315	330 × 315	500 × 145	50	50	32	32	15	38/40 × 224	63	400	215	403
	.5031.2.						50	40								
	.5031.3.						40	50								
	.5031.4.						40	40								
2010.	.5040.1.			500 × 400	330 × 400	500 × 230	50	50	32	32	15	38/40 × 224	63	400	300	403
	.5040.2.						50	40								
	.5040.3.						40	50								
	.5040.4.						40	40								
2010.	.5050.1.			500 × 500	330 × 500	500 × 330	50	50	32	32	15	38/40 × 224	63	400	400	403
	.5050.2.						50	40								
	.5050.3.						40	50								
	.5050.4.						40	40								
2010.	.6331.1.			630 × 315	430 × 315	630 × 115	63	63	40	36	18	48/50 × 280	77	510	195	513
	.6331.2.						63	50				48/50 × 280				
	.6331.3.						50	63				48/50 × 250				
	.6331.4.						50	50				48/50 × 250				
2010.	.6340.1.			630 × 400	430 × 400	630 × 200	63	63	40	36	18	48/50 × 280	77	510	280	513
	.6340.2.						63	50				48/50 × 280				
	.6340.3.						50	63				48/50 × 250				
	.6340.4.						50	50				48/50 × 250				
2010.	.6350.1.			630 × 500	430 × 500	630 × 300	63	63	40	36	18	48/50 × 280	77	510	380	513
	.6350.2.						63	50				48/50 × 280				
	.6350.3.						50	63				48/50 × 250				
	.6350.4.						50	50				48/50 × 250				
2010.	.6363.1.			630 × 630	430 × 630	630 × 430	63	63	40	36	18	48/50 × 280	77	510	510	513
	.6363.2.						63	50				48/50 × 280				
	.6363.3.						50	63				48/50 × 250				
	.6363.4.						50	50				48/50 × 250				
2010.	.7140.1.			710 × 400	510 × 400	710 × 200	63	63	40	36	18	48/50 × 280	77	590	280	593
	.7140.2.						63	50				48/50 × 280				
	.7140.3.						50	63				48/50 × 250				
	.7140.4.						50	50				48/50 × 250				
2010.	.7150.1.			710 × 500	510 × 500	710 × 300	63	63	40	36	18	48/50 × 280	77	590	380	593
	.7150.2.						63	50				48/50 × 280				
	.7150.3.						50	63				48/50 × 250				
	.7150.4.						50	50				48/50 × 250				
2010.	.7163.1.			710 × 630	510 × 630	710 × 430	63	63	40	36	18	48/50 × 280	77	590	510	593
	.7163.2.						63	50				48/50 × 280				
	.7163.3.						50	63				48/50 × 250				
	.7163.4.						50	50				48/50 × 250				
2010.	.8040.1.			800 × 400	600 × 400	800 × 200	63	63	40	36	18	48/50 × 280	77	680	280	683
	.8040.2.						63	50				48/50 × 280				
	.8040.3.						50	63				48/50 × 250				
	.8040.4.						50	50				48/50 × 250				
2010.	.8050.1.			800 × 500	600 × 500	800 × 300	63	63	40	36	18	48/50 × 280	77	680	380	683
	.8050.2.						63	50				48/50 × 280				
	.8050.3.						50	63				48/50 × 250				
	.8050.4.						50	50				48/50 × 250				
2010.	.8063.1.			800 × 630	600 × 630	800 × 430	63	63	40	36	18	48/50 × 280	77	680	510	683
	.8063.2.						63	50				48/50 × 280				
	.8063.3.						50	63				48/50 × 250				
	.8063.4.						50	50				48/50 × 250				

*P. = thickness combinations

Ordering Code (example):

Type of Die Set = 2010.45.
 Ext. Dimensions = 400 × 250 = 4025.
 Combination P*: c₁ = 50, c₂ = 50 = 1.
 Guides: headed sintered guide bushes = 835.
 Awork area 2 = 2
 Order No = 2010.45.4025.1.835.2

Advisory: Ordering Code

Hole pattern for the screw clamps depends on positioning of working surface, determined by part V (five) of the Order No, for example: 2010.49.2520.4.865.1
 .2

FIBRO

2010.45. 2010.47.
2010.46. 2010.49.

Standard All-Steel Die Sets
similar DIN 9868/ISO 11415
without stripper

Type	Size P*	Guides type	ext. dims. $a_1 \times b_1$	work area $a_2 \times b_1$	work area $a_1 \times a_3$	work area $a_1 \times a_4$	C_1 ± 2	C_2 ± 2	C_4 S	C_4 K	$d_1/d_2 \times l$	D	e_1	e_2	e_3	e_4
2010.	.1608.1.	.	160 × 80	60 × 80	-	-	32	32	20	36	19/20 × 160	39	100	-	-	-
	.1610.1.	.	160 × 100	60 × 100	-	160 × 50	32	32	20	36	19/20 × 160	39	100	-	70	-
	.1612.1.	.	160 × 125	60 × 125	-	160 × 75	32	32	20	36	19/20 × 160	39	100	-	95	-
	.1616.1.	.	160 × 160	60 × 160	160 × 60	160 × 110	32	32	20	36	19/20 × 160	39	100	100	130	103
2010.	.2010.1.	.	200 × 100	70 × 100	-	-	40	40	36	56	24/25 × 180	46	120	-	-	-
	.2010.2.	.					40	32								
	.2010.3.	.					32	40								
	.2010.4.	.					32	32								
2010.	.2012.1.	.	200 × 125	70 × 125	-	200 × 60	40	40	36	56	24/25 × 180	46	120	-	85	-
	.2012.2.	.					40	32								
	.2012.3.	.					32	40								
	.2012.4.	.					32	32								
2010.	.2016.1.	.	200 × 160	70 × 160	-	200 × 95	40	40	36	56	24/25 × 180	46	120	-	120	-
	.2016.2.	.					40	32								
	.2016.3.	.					32	40								
	.2016.4.	.					32	32								
2010.	.2020.1.	.	200 × 200	70 × 200	200 × 70	200 × 135	40	40	36	56	24/25 × 180	46	120	120	160	123
	.2020.2.	.					40	32								
	.2020.3.	.					32	40								
	.2020.4.	.					32	32								
2010.	.2512.1.	.	250 × 125	120 × 125	-	250 × 60	40	40	36	56	24/25 × 180	46	170	-	85	-
	.2512.2.	.					40	32								
	.2512.3.	.					32	40								
	.2512.4.	.					32	32								
2010.	.2516.1.	.	250 × 160	120 × 160	-	250 × 95	40	40	36	56	24/25 × 180	46	170	-	120	-
	.2516.2.	.					40	32								
	.2516.3.	.					32	40								
	.2516.4.	.					32	32								
2010.	.2520.1.	.	250 × 200	120 × 200	250 × 70	250 × 135	40	40	36	56	24/25 × 180	46	170	120	160	173
	.2520.2.	.					40	32								
	.2520.3.	.					32	40								
	.2520.4.	.					32	32								
2010.	.2525.1.	.	250 × 250	120 × 250	250 × 120	250 × 185	40	40	36	56	24/25 × 180	46	170	170	210	173
	.2525.2.	.					40	32								
	.2525.3.	.					32	40								
	.2525.4.	.					32	32								
2010.	.3116.1.	.	315 × 160	165 × 160	-	315 × 85	50	50	45	63	30/32 × 200	53	225	-	115	-
	.3116.2.	.					50	40								
	.3116.3.	.					40	50								
	.3116.4.	.					40	40								
2010.	.3120.1.	.	315 × 200	165 × 200	315 × 50	315 × 125	50	50	45	63	30/32 × 200	53	225	110	155	228
	.3120.2.	.					50	40								
	.3120.3.	.					40	50								
	.3120.4.	.					40	40								
2010.	.3125.1.	.	315 × 250	165 × 250	315 × 100	315 × 175	50	50	45	63	30/32 × 200	53	225	160	205	228
	.3125.2.	.					50	40								
	.3125.3.	.					40	50								
	.3125.4.	.					40	40								
2010.	.3131.1.	.	315 × 315	165 × 315	315 × 165	315 × 240	50	50	45	63	30/32 × 200	53	225	225	270	228
	.3131.2.	.					50	40								
	.3131.3.	.					40	50								
	.3131.4.	.					40	40								
2010.	.4020.1.	.	400 × 200	250 × 200	400 × 50	400 × 125	50	50	45	63	30/32 × 200	53	310	110	155	313
	.4020.2.	.					50	40								
	.4020.3.	.					40	50								
	.4020.4.	.					40	40								
2010.	.4025.1.	.	400 × 250	250 × 250	400 × 100	400 × 175	50	50	45	63	30/32 × 200	53	310	160	205	313
	.4025.2.	.					50	40								
	.4025.3.	.					40	50								
	.4025.4.	.					40	40								
2010.	.4031.1.	.	400 × 315	250 × 315	400 × 165	400 × 240	50	50	45	63	30/32 × 200	53	310	225	270	313
	.4031.2.	.					50	40								
	.4031.3.	.					40	50								
	.4031.4.	.					40	40								

Standard All-Steel Die Sets
similar DIN 9868/ISO 11415
with stripper

FIBRO

2010.45. 2010.46.
2010.49.

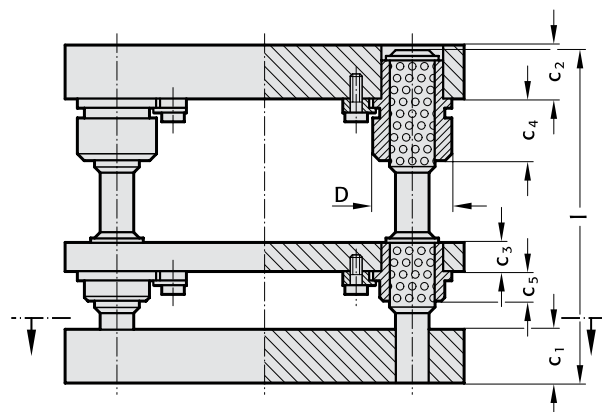
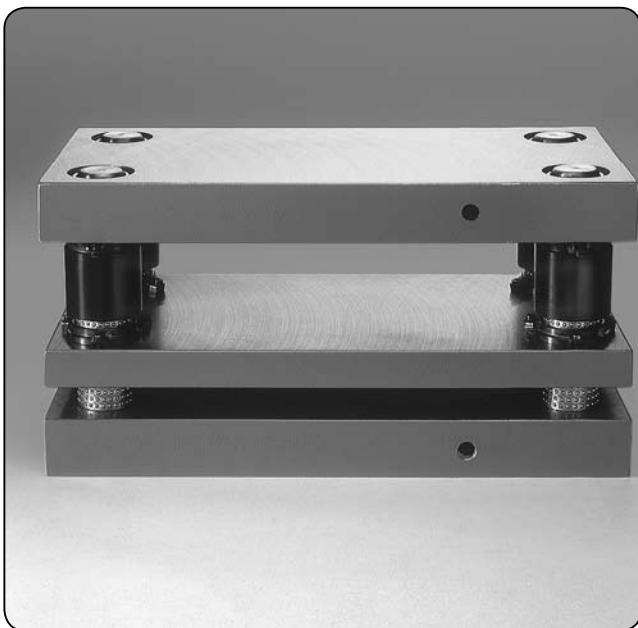

2010.45.

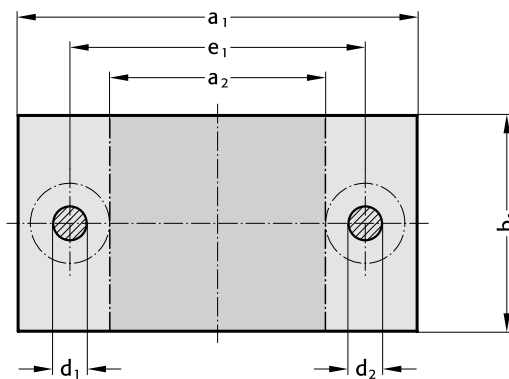

2010.46.

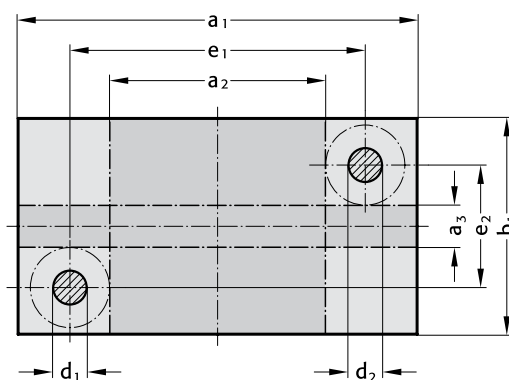

2010.49.

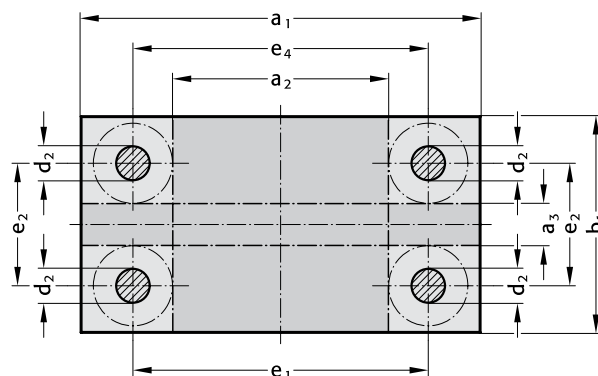

Standard Guide Systems

Headed Sintered Ferrite Bushes, carbonitrided

Headed Ball Bearing Bushes

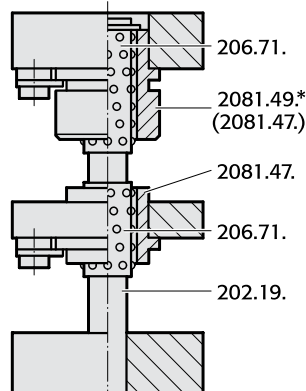
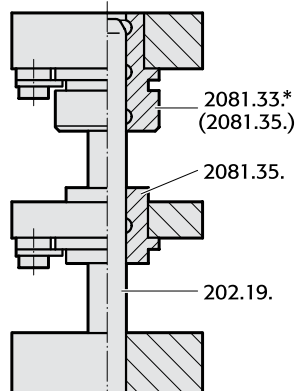

Order No (part IV)
2010.□□.□□□□.□.835.

Order No (part IV)
2010.□□.□□□□.□.865.

* up to size 2010.□□.1616. = 2081.35./2081.47.

Description:

FIBRO Standard All-Steel Die Sets offer the choice between sintered ferrite sliding guides and those of the ball bearing type to DIN/ISO. Both come with headed guide bushes. These are seated in push-fit bolster bores and retained there by screw clamps.

On request, All-Steel Die Sets can also be fitted with any other FIBRO Guide Elements – for combination possibilities see page A 30.

FIBRO will furthermore supply die sets with special machining features to customers' drawings.

Execution:

External contours milled, thickness surfaces ground

a_1 or $b_1 \leq 630 = \begin{matrix} +0,4 \\ +0,2 \end{matrix}$

a_1 or $b_1 > 630 = \begin{matrix} +0,6 \\ +0,2 \end{matrix}$

Ordering example see opposite fold out page.

Die Sets to Costumers' Specifications

Please copy this page, complete questions, and mail to FIBRO GmbH.

201.45.
201.65.

without stripper

with stripper

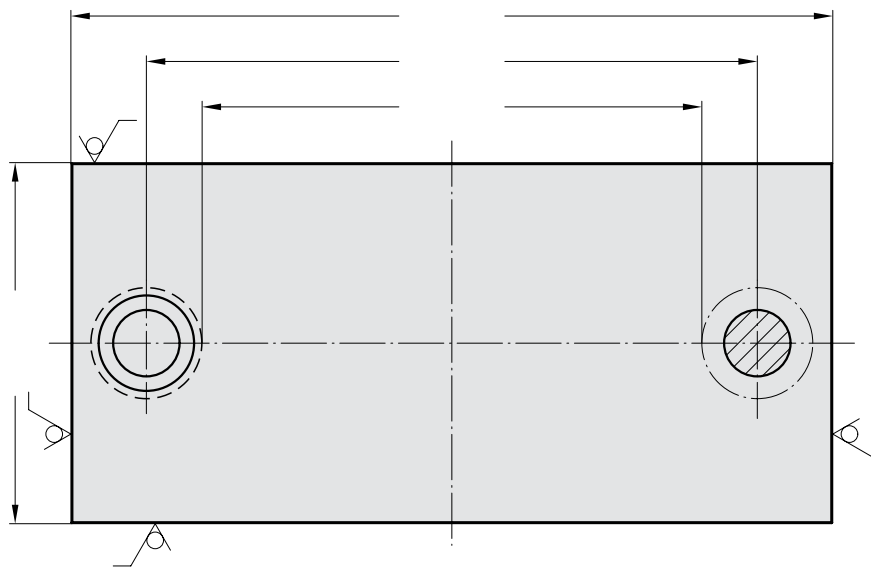
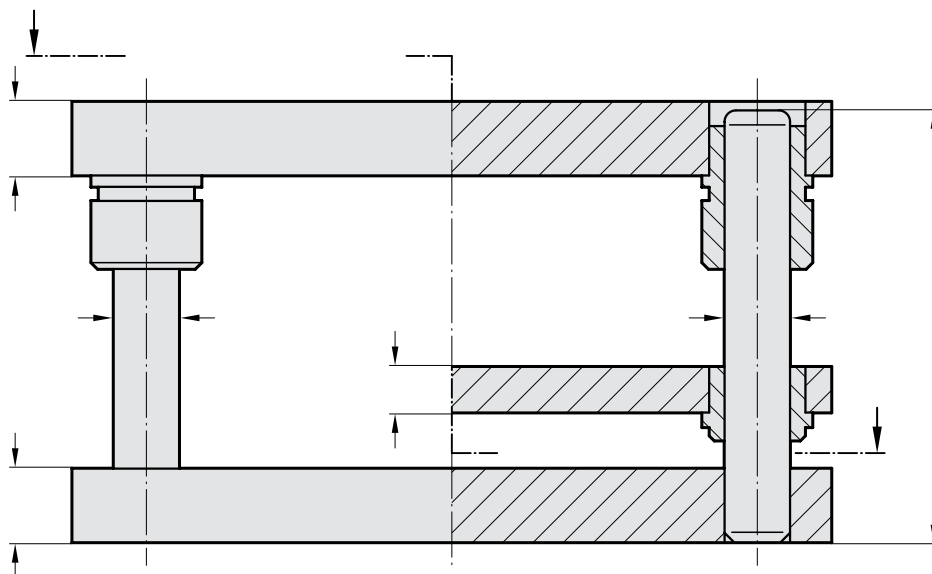

Guide Pillars

202.19. Guide Pillar
DIN 9825/ISO 9182-2

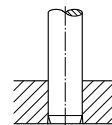

202.21. Guide Pillar
endwise bolt-on type

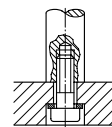

2021.46. Demountable Pillars
with collar, push fit,
screw clamp retention

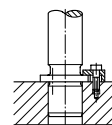

2021.46. Demountable Pillars
with collar, push fit,
screw clamp retention
2021.43. Disc and screw

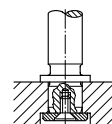

2021.50. Demountable Pillar,
conical, central screw
retention
2021.39. Liner Bush
2021.53. Disc and
Screw

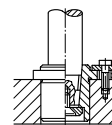

202.60. Stripper-Mounted
Pillars with Collar,
demountable, push fit,
ring nut retention

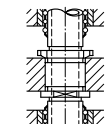

Guide Bushes

2031.34. Mounting
Flanges, rectangular;
sintered guide bush,
carbonitrided
2031.42. ditto -
Ball bearing Guide Bush
206.71. Ball Cage

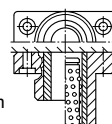

2031.38. Shallow Mounting
Flanges, rectan-
gular; sintered guide
bush, carbonitrided
2031.44. ditto - Ball
bearing Guide Bush
206.71. Ball Cage

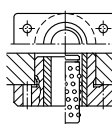

2051.32. Sintered Ferrite Guide
Bush, carbonitrided,
bonded
2061.44. Guide
Bush for Ball
Bearing Guide
206.71. Ball Cage

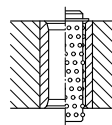

2081.31./32./33./34./35.
Headed Guide Bushes,
Sintered Ferrite,
carbonitrided
2081.44./45./46./
47./49. Guide Bushes
for Ball Bearing Guide
206.71. Ball Cage

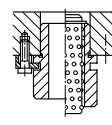

2091.31./32./34. Flanged Guide
Bushes, Sintered Ferrite,
carbonitrided
2091.44./45./46.
Guide Bushes for
Ball Bearing Guide,
push fit
206.71. Ball Cage

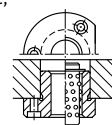

Enquiry Order

Material: Aluminium 201.65.

Steel 201.45.

Company

Telephone

Name (ref. for replies)

Signature

FIBRO

201.46.
201.66.

Die Sets to Customers' Specifications

Please copy this page, complete questions, and mail to FIBRO GmbH.

Guide Pillars

202.19.
Guide Pillar
DIN 9825/ISO 9182-2

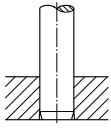

202.21.
Guide Pillar
endwise bolt-on type

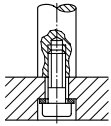

201.46.
Demountable Pillars
with collar, push fit,
screw clamp retention

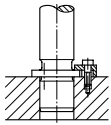

201.46.
Demountable Pillars
with collar, push fit,
screw clamp retention
201.43.
Disc and screw

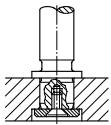

2021.50.
Demountable Pillar,
conical, central screw
retention
2021.39. Liner Bush
2021.53. Disc and
Screw

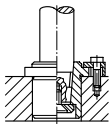

202.60.
Stripper-Mounted
Pillars with Collar,
demountable, push fit,
ring nut retention

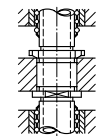

Guide Bushes
2031.34. Mounting
Flanges, rectangular;
sintered guide bush,
carbonitrided
2031.42. ditto –
Ball bearing Guide Bush

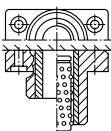

206.71. Ball Cage
2031.38.
Shallow Mounting
Flanges, rectan-
gular; sintered guide
bush, carbonitrided
2031.44. ditto – Ball
bearing Guide Bush
206.71. Ball Cage

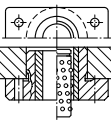

2051.32.
Sintered Ferrite Guide
Bush, carbonitrided,
bonded
2061.44. Guide
Bush for Ball
Bearing Guide
206.71. Ball Cage

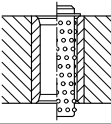

2081.31./32./33./34./35.
Headed Guide Bushes,
Sintered Ferrite,
carbonitrided
2081.44./45./46./
47./49. Guide Bushes
for Ball Bearing Guide
206.71. Ball Cage

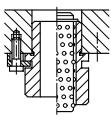

2091.31./32./34. Flanged Guide
Bushes, Sintered Ferrite,
carbonitrided
2091.44./45./46.
Guide Bushes for
Ball Bearing Guide,
push fit
206.71. Ball Cage

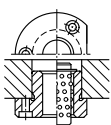

without stripper

with stripper

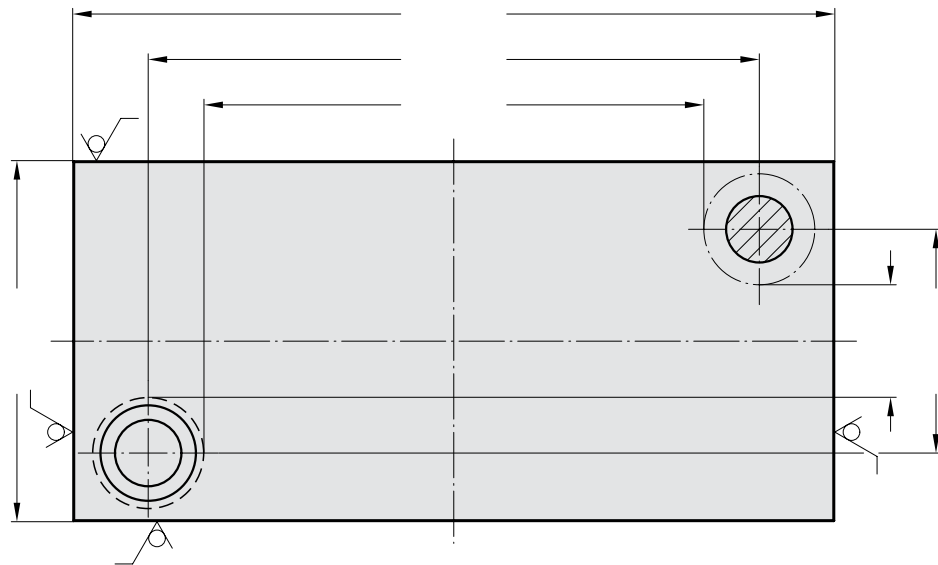
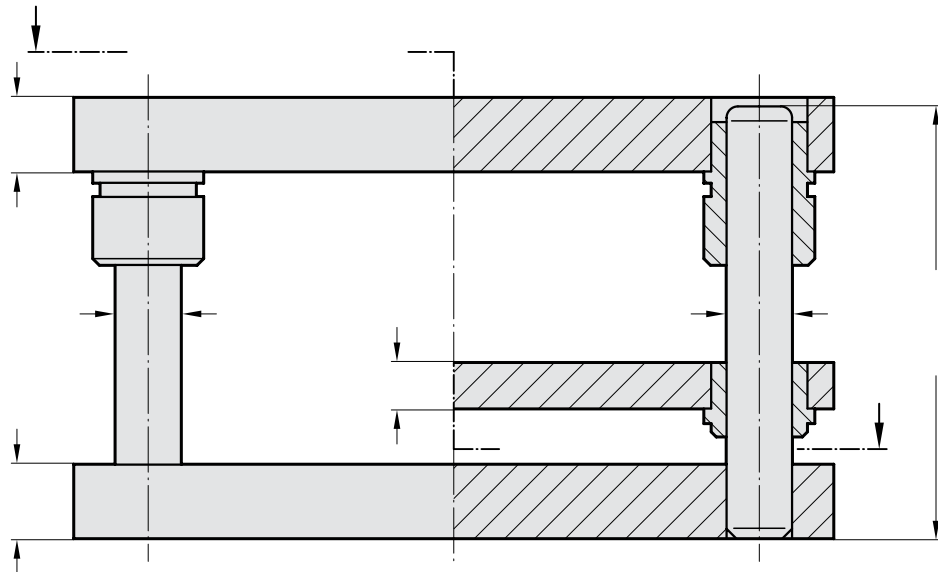

Enquiry Order

Material: Aluminium 201.66.

Steel 201.46.

Company

Telephone

Name (ref. for replies)

Signature

Die Sets to Customers' Specifications

Please copy this page, complete questions, and mail to FIBRO GmbH.

without stripper

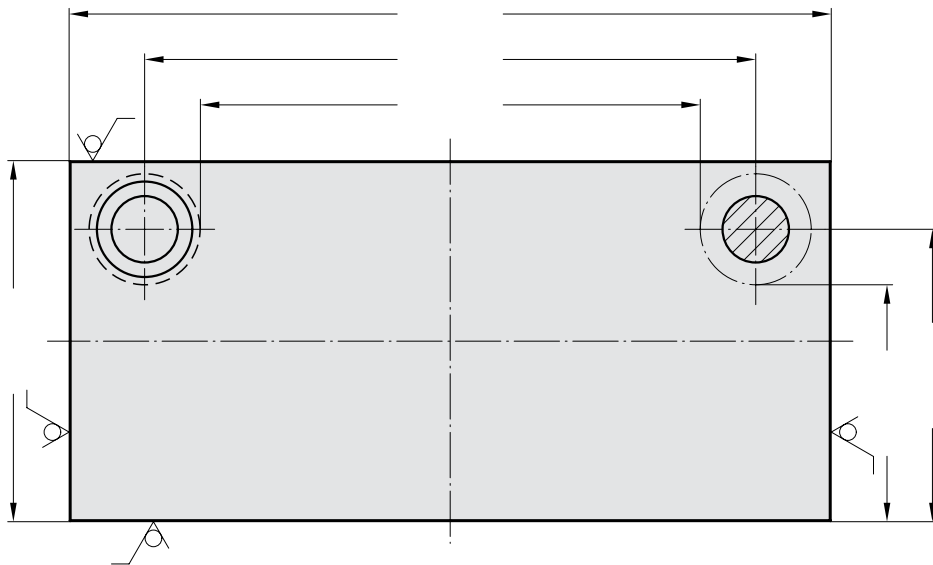
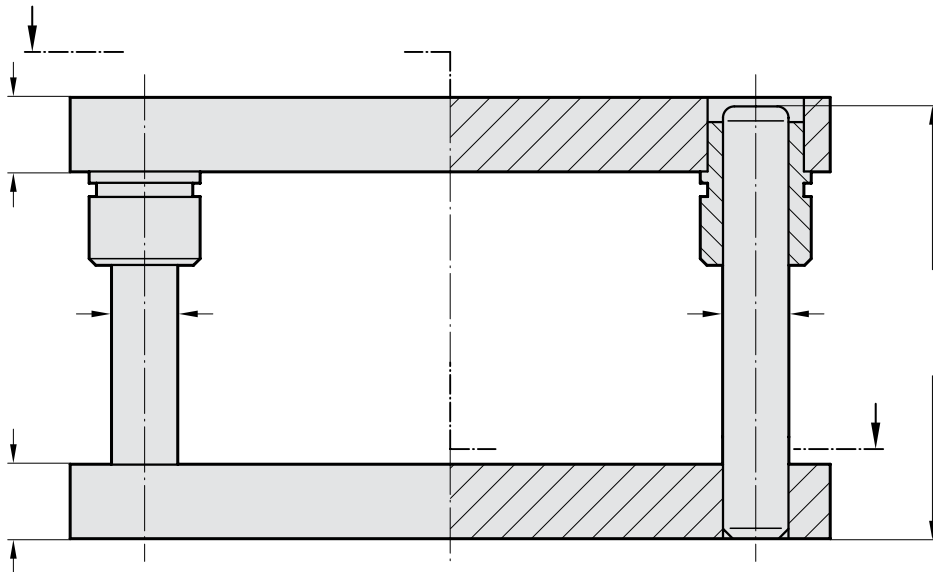

Guide Pillars

202.19.
Guide Pillar
DIN 9825/ISO 9182-2

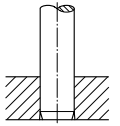

202.21.
Guide Pillar
endwise bolt-on type

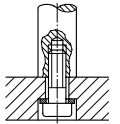

2021.46.
Demountable Pillars
with collar, push fit,
screw clamp retention

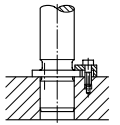

2021.46.
Demountable Pillars
with collar, push fit,
screw clamp retention
2021.43.
Disc and screw

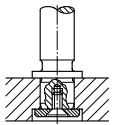

2021.50.
Demountable Pillar,
conical, central screw
retention
2021.39. Liner Bush
2021.53. Disc and
Screw

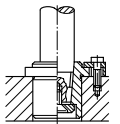

Guide Bushes

2031.34. Mounting
Flanges, rectangular;
sintered guide bush,
carbonitrided

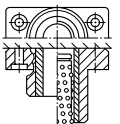

2031.42. ditto –
Ball bearing Guide Bush

206.71. Ball Cage

2031.38.
Shallow Mounting
Flanges, rectan-
gular; sintered guide
bush, carbonitrided
2031.44. ditto – Ball
bearing Guide Bush
206.71. Ball Cage

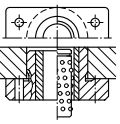

2051.32.
Sintered Ferrite Guide
Bush, carbonitrided,
bonded
2061.44. Guide
Bush for Ball
Bearing Guide
206.71. Ball Cage

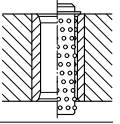

2081.31./32./33./34./35.
Headed Guide Bushes,
Sintered Ferrite,
carbonitrided
2081.44./45./46./
47./49. Guide Bushes
for Ball Bearing Guide
206.71. Ball Cage

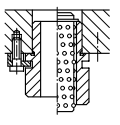

2091.31./32./34. Flanged Guide
Bushes, Sintered Ferrite,
carbonitrided
2091.44./45./46.
Guide Bushes for
Ball Bearing Guide,
push fit
206.71. Ball Cage

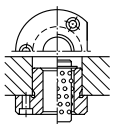

Enquiry Order

Material: Aluminium 201.67.

Steel 201.47.

Company

Telephone

Name (ref. for replies)

Signature

FIBRO

201.49.
201.69.

Die Sets to Customers' Specifications

Please copy this page, complete questions, and mail to FIBRO GmbH.

Guide Pillars

202.19.
Guide Pillar
DIN 9825/ISO 9182-2

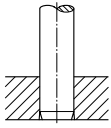

202.21.
Guide Pillar
endwise bolt-on type

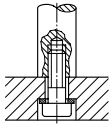

2021.46.
Demountable Pillars
with collar, push fit,
screw clamp retention

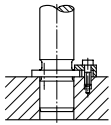

2021.46.
Demountable Pillars
with collar, push fit,
screw clamp retention
2021.43.
Disc and screw

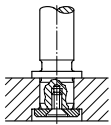

2021.50.
Demountable Pillar,
conical, central screw
retention
2021.39. Liner Bush
2021.53. Disc and
Screw

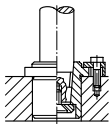

202.60.
Stripper-Mounted
Pillars with Collar,
demountable, push fit,
ring nut retention

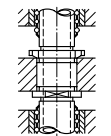

Guide Bushes
2031.34. Mounting
Flanges, rectangular;
sintered guide bush,
carbonitrided
2031.42. ditto –
Ball bearing Guide Bush
206.71. Ball Cage

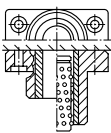

2031.38.
Shallow Mounting
Flanges, rectan-
gular; sintered guide
bush, carbonitrided
2031.44. ditto – Ball
bearing Guide Bush
206.71. Ball Cage

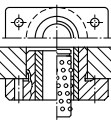

2051.32.
Sintered Ferrite Guide
Bush, carbonitrided,
bonded
2061.44. Guide
Bush for Ball
Bearing Guide
206.71. Ball Cage

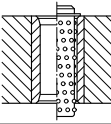

2081.31./32./33./34./35.
Headed Guide Bushes,
Sintered Ferrite,
carbonitrided
2081.44./45./46./
47./49. Guide Bushes
for Ball Bearing Guide
206.71. Ball Cage

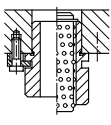

2091.31./32./34. Flanged Guide
Bushes, Sintered Ferrite,
carbonitrided
2091.44./45./46.
Guide Bushes for
Ball Bearing Guide,
push fit
206.71. Ball Cage

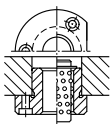

without stripper

with stripper

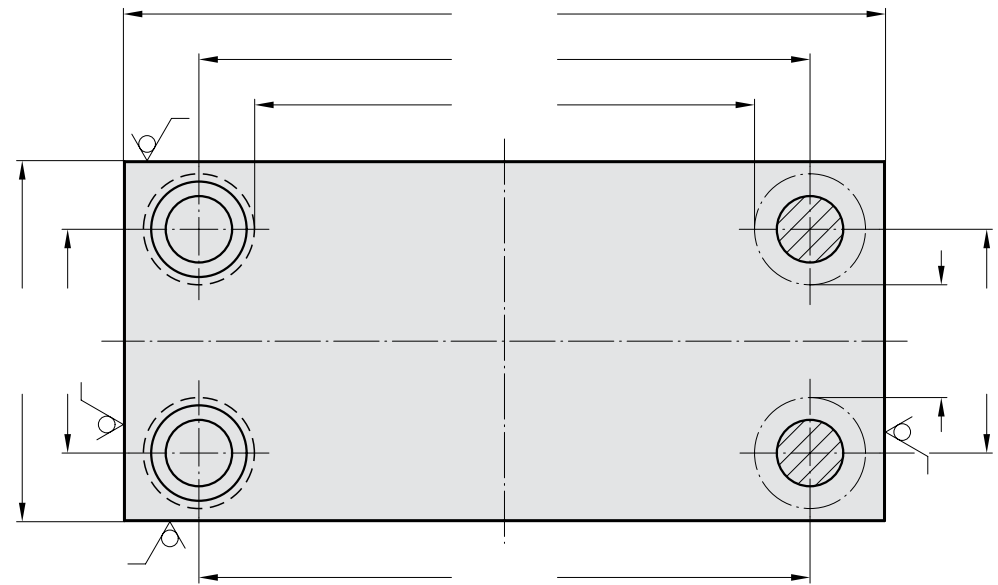
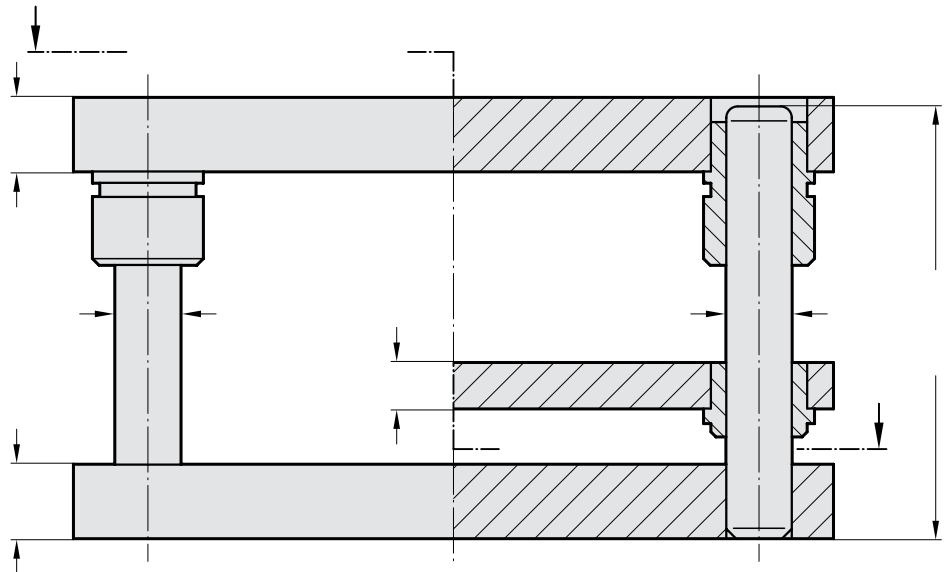

Enquiry Order

Material: Aluminium 201.69.

Steel 201.49.

Company

Telephone

Name (ref. for replies)

Signature

ECO-LINE
All-Steel Die Sets
with / without Stripper

FIBRO

2010.55. 2010.57.
 2010.59.

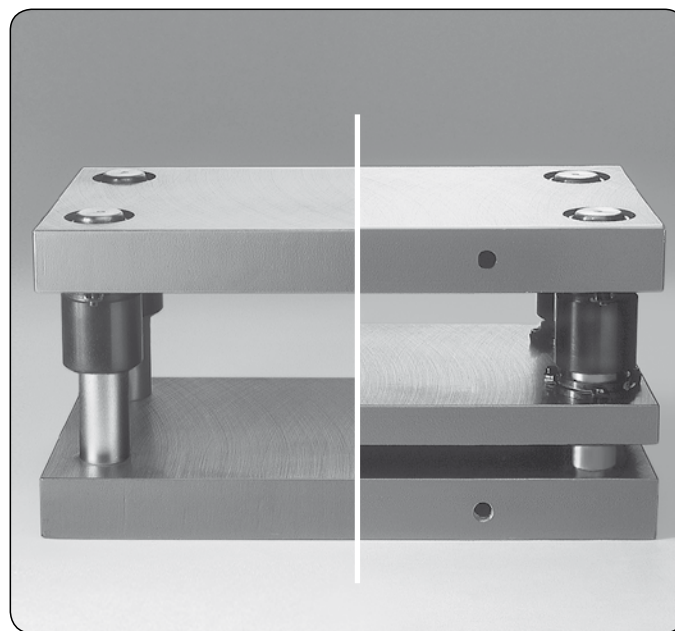
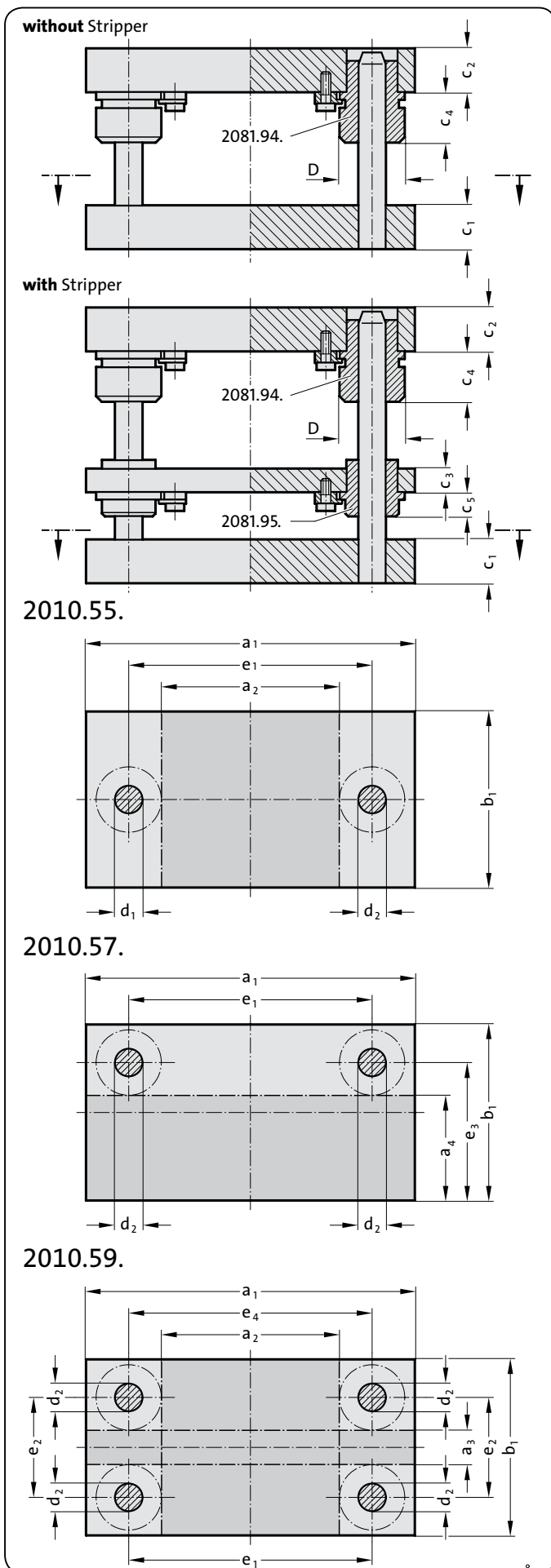

Executions:

With press-fitted guide pillars 202.29.

Headed Guide Bushes bronze plated **without** stripper

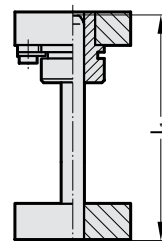

2010.5 □ . □ . 894

Headed Guide Bushes bronze plated **with** stripper

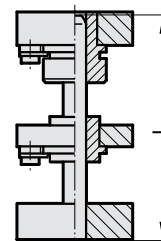

2010.5 □ . □ . 895

With demountable guide pillars 2021.29.***

Headed Guide Bushes bronze plated **without** stripper

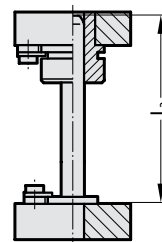

2010.5 □ . □ . 894.29

Headed Guide Bushes bronze plated **with** stripper

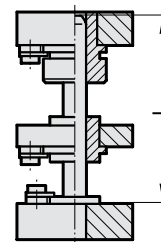

2010.5 □ . □ . 895.29

Description:

FIBRO 2010.5x all-steel die sets are supplied with bronze plated guide bushes. These are supplied in push-fit bolster bores and retained by screw clamps.

Execution:

External contours milled
 Thickness surfaces ground

Note:

*** to be fixed only with screw clamps

FIBRO

2010.55. 2010.57.
2010.59.

ECO-LINE

All-Steel Die Sets
with / without Stripper

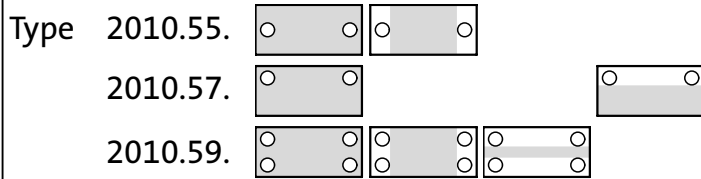

Order No

Type	Size P.*	Execution	Execution***	Ext. dimensions		Work area(s)**		c ₁	c ₂	c ₃	c ₄	c ₅	d ₁ /d ₂	l ₁ /l ₂	l ₃ /l ₄	D	e ₁	e ₂	e ₃	e ₄
				a ₁ x b ₁	a ₂ x b ₁	a ₁ x a ₃	a ₁ x a ₄	± 2	± 2	± 2										
2010.55.2512.1.				250 x 125	120 x 125	-	-	40	40	32	36	12	24/25	180/200	140/180	46	170	-	-	-
2010.55.2512.4.				250 x 125	120 x 125	-	-	32	32	32	36	12	24/25	180/200	140/180	46	170	-	-	-
2010.57.2520.1.	8 9 4			250 x 200	-	-	250 x 135	40	40	-	36	-	-/25	180/-	140/-	46	170	-	160	-
2010.57.2520.4.	8 9 4			250 x 200	-	-	250 x 135	32	32	-	36	-	-/25	180/-	140/-	46	170	-	160	-
2010.59.2520.4.				250 x 200	120 x 200	250 x 50	-	32	32	32	36	12	-/25	180/200	140/180	46	170	120	-	173
2010.59.2525.4.				250 x 250	120 x 250	250 x 100	-	32	32	32	36	12	-/25	180/200	140/180	46	170	170	-	173
2010.55.3116.1.				315 x 160	165 x 160	-	-	50	50	32	45	12	30/32	200/224	160/200	53	225	-	-	-
2010.55.3116.4.				315 x 160	165 x 160	-	-	40	40	32	45	12	30/32	200/224	160/200	53	225	-	-	-
2010.55.3120.4.				315 x 200	165 x 200	-	-	40	40	32	45	12	30/32	200/224	160/200	53	225	-	-	-
2010.57.3120.4.	8 9 4			315 x 200	-	-	315 x 125	40	40	-	45	-	-/32	200/-	160/-	53	225	-	155	-
2010.59.3120.4.				315 x 200	165 x 200	315 x 30	-	40	40	32	45	12	-/32	200/224	160/200	53	225	110	-	228
2010.57.3125.1.	8 9 4			315 x 250	-	-	315 x 175	50	50	-	45	-	-/32	200/-	160/-	53	225	-	205	-
2010.59.3125.1.				315 x 250	165 x 250	315 x 80	-	50	50	32	45	12	-/32	200/224	160/200	53	225	160	-	228
2010.59.3125.4.				315 x 250	165 x 250	315 x 80	-	40	40	32	45	12	-/32	200/224	160/200	53	225	160	-	228
2010.59.3131.1.				315 x 315	165 x 315	315 x 145	-	50	50	32	45	12	-/32	200/224	160/200	53	225	225	-	228
2010.55.4020.4.				400 x 200	250 x 200	-	-	40	40	32	45	12	30/32	200/224	160/200	53	310	-	-	-
2010.59.4020.4.				400 x 200	250 x 200	400 x 30	-	40	40	32	45	12	-/32	200/224	160/200	53	310	110	-	313
2010.55.4025.1.				400 x 250	250 x 250	-	-	50	50	32	45	12	30/32	200/224	160/200	53	310	-	-	-
2010.57.4025.1.	8 9 4			400 x 250	-	-	400 x 175	50	50	-	45	-	-/32	200/-	160/-	53	310	-	205	-
2010.59.4025.1.				400 x 250	250 x 250	400 x 80	-	50	50	32	45	12	-/32	200/224	160/200	53	310	160	-	313
2010.59.4025.4.				400 x 250	250 x 250	400 x 80	-	40	40	32	45	12	-/32	200/224	160/200	53	310	160	-	313
2010.57.4031.4.	8 9 4			400 x 315	-	-	400 x 240	40	40	-	45	-	-/32	200/-	160/-	53	310	-	270	-
2010.59.4031.1.				400 x 315	250 x 315	400 x 145	-	50	50	32	45	12	-/32	200/224	160/200	53	310	225	-	313
2010.59.4040.1.				400 x 400	250 x 400	400 x 230	-	50	50	32	45	12	-/32	200/224	160/200	53	310	310	-	313
2010.59.4040.4.				400 x 400	250 x 400	400 x 230	-	40	40	32	45	12	-/32	200/224	160/200	53	310	310	-	313
2010.55.5025.1.				500 x 250	325 x 250	-	-	50	50	32	45	15	38/40	200/224	160/200	63	400	-	-	-
2010.59.5025.1.				500 x 250	325 x 250	500 x 75	-	50	50	32	45	15	-/40	200/224	160/200	63	400	150	-	403
2010.59.5025.4.				500 x 250	325 x 250	500 x 75	-	40	40	32	45	15	-/40	200/224	160/200	63	400	150	-	403
2010.55.5031.1.				500 x 315	325 x 315	-	-	50	50	32	45	15	38/40	200/224	160/200	63	400	-	-	-
2010.59.5031.1.				500 x 315	325 x 315	500 x 140	-	50	50	32	45	15	-/40	200/224	160/200	63	400	215	-	403
2010.59.5040.1.				500 x 400	325 x 400	500 x 225	-	50	50	32	45	15	-/40	200/224	160/200	63	400	300	-	403
2010.59.5050.1.				500 x 500	325 x 500	500 x 325	-	50	50	32	45	15	-/40	200/224	160/200	63	400	400	-	403

*Thickness combinations

**Work area dimensions are not affected by the positions of the screw clamps that retain the bushes!

***With demountable guide pillars 2021.29.

Next day delivery!

Ordering Code (example):

Type of Die Set (external dimensions a, x b₁ = 400 x 250; c₁ = c₂ = 50) = 2010.55.4025.1.
 Execution with stripper = 895.
 with demountable guide pillars 2021.29. = 29
 Order No = 2010.55.4025.1.895.29

Ordering Code (example):

Type of Die Set (external dimensions a, x b₁ = 400 x 250; c₁ = c₂ = 50) = 2010.55.4025.1.
 Execution with stripper = 895
 Order No = 2010.55.4025.1.895

Steel plate to ISO 6753-1

2900.

2900.

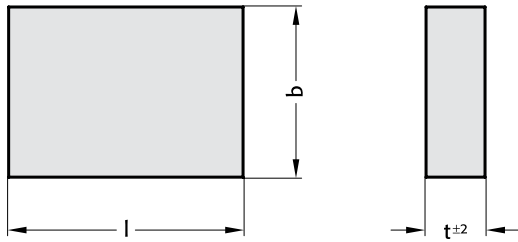

Execution:

External contours milled, thickness surfaces ground

Note:

l or b ≤ 630 = $\begin{matrix} +0,4 \\ +0,2 \end{matrix}$

l or b > 630 = $\begin{matrix} +0,6 \\ +0,2 \end{matrix}$

Bolsters from 500 X 500 mm on are manufactured with a lifting thread.

Ordering Code (example):

Steel plate	=	2900
length	400 mm	= .40
width	400 mm	= 40
thickness	32 mm	= .32
Order No	=	2900.4040.32

2900.

Order No	Size l x b x t	Order No	Size l x b x t	Order No	Size l x b x t
2900.1608.25	160 x 80 x 25	40	400 x 250 x 40	2900.8040.32	800 x 400 x 32
32	160 x 80 x 32	50	400 x 250 x 50	40	800 x 400 x 40
2900.1610.25	160 x 100 x 25	2900.4031.32	400 x 315 x 32	50	800 x 400 x 50
32	160 x 100 x 32	40	400 x 315 x 40	63	800 x 400 x 63
2900.1612.25	160 x 125 x 25	50	400 x 315 x 50	2900.8050.32	800 x 500 x 32
32	160 x 125 x 32	2900.4040.32	400 x 400 x 32	40	800 x 500 x 40
2900.1616.25	160 x 160 x 25	40	400 x 400 x 40	50	800 x 500 x 50
32	160 x 160 x 32	50	400 x 400 x 50	63	800 x 500 x 63
2900.2010.25	200 x 100 x 25	2900.5025.32	500 x 250 x 32	2900.8063.32	800 x 630 x 32
32	200 x 100 x 32	40	500 x 250 x 40	40	800 x 630 x 40
40	200 x 100 x 40	50	500 x 250 x 50	50	800 x 630 x 50
2900.2012.25	200 x 125 x 25	2900.5031.32	500 x 315 x 32	63	800 x 630 x 63
32	200 x 125 x 32	40	500 x 315 x 40		
40	200 x 125 x 40	50	500 x 315 x 50		
2900.2016.25	200 x 160 x 25	2900.5040.32	500 x 400 x 32		
32	200 x 160 x 32	40	500 x 400 x 40		
40	200 x 160 x 40	50	500 x 400 x 50		
2900.2020.25	200 x 200 x 25	2900.5050.32	500 x 500 x 32		
32	200 x 200 x 32	40	500 x 500 x 40		
40	200 x 200 x 40	50	500 x 500 x 50		
2900.2512.25	250 x 125 x 25	2900.6331.32	630 x 315 x 32		
32	250 x 125 x 32	40	630 x 315 x 40		
40	250 x 125 x 40	50	630 x 315 x 50		
2900.2516.25	250 x 160 x 25	63	630 x 315 x 63		
32	250 x 160 x 32	2900.6340.32	630 x 400 x 32		
40	250 x 160 x 40	40	630 x 400 x 40		
2900.2520.25	250 x 200 x 25	50	630 x 400 x 50		
32	250 x 200 x 32	63	630 x 400 x 63		
40	250 x 200 x 40	2900.6350.32	630 x 500 x 32		
2900.2525.25	250 x 250 x 25	40	630 x 500 x 40		
32	250 x 250 x 32	50	630 x 500 x 50		
40	250 x 250 x 40	63	630 x 500 x 63		
2900.3116.32	315 x 160 x 32	2900.6363.32	630 x 630 x 32		
40	315 x 160 x 40	40	630 x 630 x 40		
50	315 x 160 x 50	50	630 x 630 x 50		
2900.3120.32	315 x 200 x 32	63	630 x 630 x 63		
40	315 x 200 x 40	2900.7140.32	710 x 400 x 32		
50	315 x 200 x 50	40	710 x 400 x 40		
2900.3125.32	315 x 250 x 32	50	710 x 400 x 50		
40	315 x 250 x 40	63	710 x 400 x 63		
50	315 x 250 x 50	2900.7150.32	710 x 500 x 32		
2900.3131.32	315 x 315 x 32	40	710 x 500 x 40		
40	315 x 315 x 40	50	710 x 500 x 50		
50	315 x 315 x 50	63	710 x 500 x 63		
2900.4020.32	400 x 200 x 32	2900.7163.32	710 x 630 x 32		
40	400 x 200 x 40	40	710 x 630 x 40		
50	400 x 200 x 50	50	710 x 630 x 50		
2900.4025.32	400 x 250 x 32	63	710 x 630 x 63		

2910.

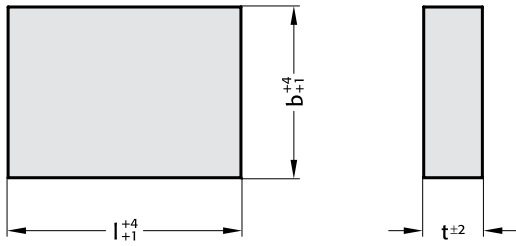

Execution:

2910.□□□□.□□.0
External contours sawed
Thickness surfaces ground

Bolsters from 500 × 500 mm on are manufactured with a lifting thread.

2910.

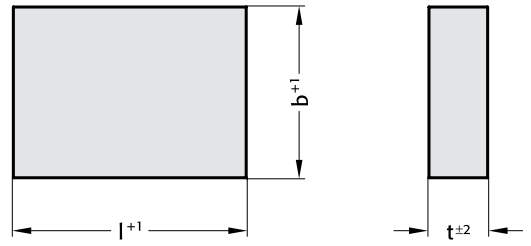

Execution:

2910.□□□□.□□.2
Two external contours milled
Thickness surfaces ground

Bolsters from 500 × 500 mm on are manufactured with a lifting thread.

2910.

Order No	Size l x b x t	Order No	Size l x b x t	Order No	Size l x b x t
2910.1608.25.□	160 x 80 x 25	40.□	400 x 250 x 40	2910.8040.32.□	800 x 400 x 32
32.□	160 x 80 x 32	50.□	400 x 250 x 50	40.□	800 x 400 x 40
2910.1610.25.□	160 x 100 x 25	2910.4031.32.□	400 x 315 x 32	50.□	800 x 400 x 50
32.□	160 x 100 x 32	40.□	400 x 315 x 40	63.□	800 x 400 x 63
2910.1612.25.□	160 x 125 x 25	50.□	400 x 315 x 50	2910.8050.32.□	800 x 500 x 32
32.□	160 x 125 x 32	2910.4040.32.□	400 x 400 x 32	40.□	800 x 500 x 40
2910.1616.25.□	160 x 160 x 25	40.□	400 x 400 x 40	50.□	800 x 500 x 50
32.□	160 x 160 x 32	50.□	400 x 400 x 50	63.□	800 x 500 x 63
2910.2010.25.□	200 x 100 x 25	2910.5025.32.□	500 x 250 x 32	2910.8063.32.□	800 x 630 x 32
32.□	200 x 100 x 32	40.□	500 x 250 x 40	40.□	800 x 630 x 40
40.□	200 x 100 x 40	50.□	500 x 250 x 50	50.□	800 x 630 x 50
2910.2012.25.□	200 x 125 x 25	2910.5031.32.□	500 x 315 x 32	63.□	800 x 630 x 63
32.□	200 x 125 x 32	40.□	500 x 315 x 40		
40.□	200 x 125 x 40	50.□	500 x 315 x 50		
2910.2016.25.□	200 x 160 x 25	2910.5040.32.□	500 x 400 x 32		
32.□	200 x 160 x 32	40.□	500 x 400 x 40		
40.□	200 x 160 x 40	50.□	500 x 400 x 50		
2910.2020.25.□	200 x 200 x 25	2910.5050.32.□	500 x 500 x 32		
32.□	200 x 200 x 32	40.□	500 x 500 x 40		
40.□	200 x 200 x 40	50.□	500 x 500 x 50		
2910.2512.25.□	250 x 125 x 25	2910.6331.32.□	630 x 315 x 32		
32.□	250 x 125 x 32	40.□	630 x 315 x 40		
40.□	250 x 125 x 40	50.□	630 x 315 x 50		
2910.2516.25.□	250 x 160 x 25	63.□	630 x 315 x 63		
32.□	250 x 160 x 32	2910.6340.32.□	630 x 400 x 32		
40.□	250 x 160 x 40	40.□	630 x 400 x 40		
2910.2520.25.□	250 x 200 x 25	50.□	630 x 400 x 50		
32.□	250 x 200 x 32	63.□	630 x 400 x 63		
40.□	250 x 200 x 40	2910.6350.32.□	630 x 500 x 32		
2910.2525.25.□	250 x 250 x 25	40.□	630 x 500 x 40		
32.□	250 x 250 x 32	50.□	630 x 500 x 50		
40.□	250 x 250 x 40	63.□	630 x 500 x 63		
2910.3116.32.□	315 x 160 x 32	2910.6363.32.□	630 x 630 x 32		
40.□	315 x 160 x 40	40.□	630 x 630 x 40		
50.□	315 x 160 x 50	50.□	630 x 630 x 50		
2910.3120.32.□	315 x 200 x 32	63.□	630 x 630 x 63		
40.□	315 x 200 x 40	2910.7140.32.□	710 x 400 x 32		
50.□	315 x 200 x 50	40.□	710 x 400 x 40		
2910.3125.32.□	315 x 250 x 32	50.□	710 x 400 x 50		
40.□	315 x 250 x 40	63.□	710 x 400 x 63		
50.□	315 x 250 x 50	2910.7150.32.□	710 x 500 x 32		
2910.3131.32.□	315 x 315 x 32	40.□	710 x 500 x 40		
40.□	315 x 315 x 40	50.□	710 x 500 x 50		
50.□	315 x 315 x 50	63.□	710 x 500 x 63		
2910.4020.32.□	400 x 200 x 32	2910.7163.32.□	710 x 630 x 32		
40.□	400 x 200 x 40	40.□	710 x 630 x 40		
50.□	400 x 200 x 50	50.□	710 x 630 x 50		
2910.4025.32.□	400 x 250 x 32	63.□	710 x 630 x 63		

Ordering Code (example):

Aluminium Plate = 2910
length 400 mm = .40
width 400 mm = 40
thickness 32 mm = .32
execution ground = .0
Order No = 2910.4040.32.0

FIBRO

2010.65. 2010.67.
2010.66. 2010.69.

Standard Aluminium Die Sets similar DIN 9868/ISO 11415 without Stripper

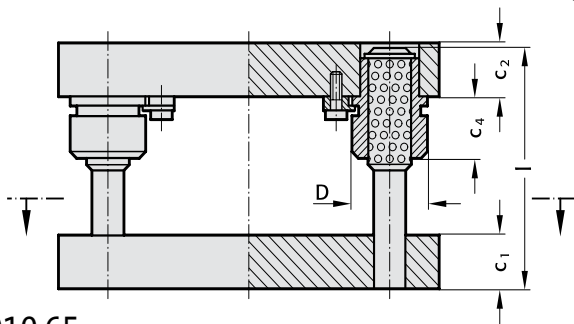

2010.65.

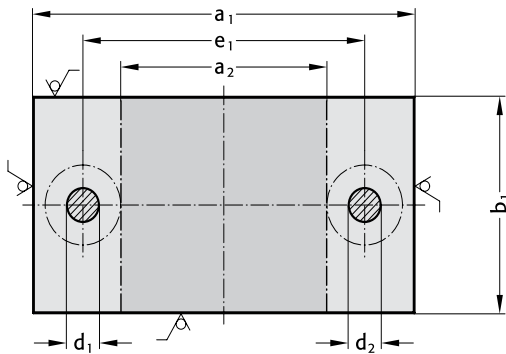

2010.66.

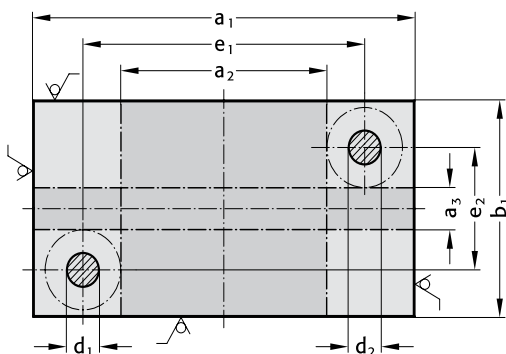

2010.67.

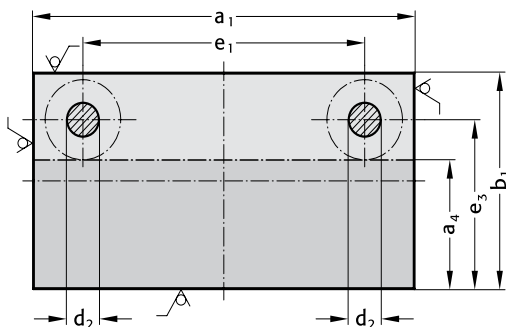

2010.69.

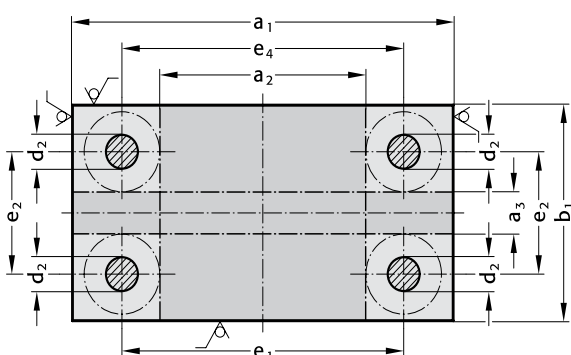

Standard Guide Systems

Headed Sintered
Ferrite Bushes,
carbonitrided

Headed Ball
Bearing Bushes

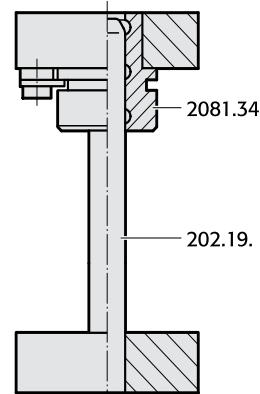

Order No (part IV)
2010.□□.□□□□.□.834.

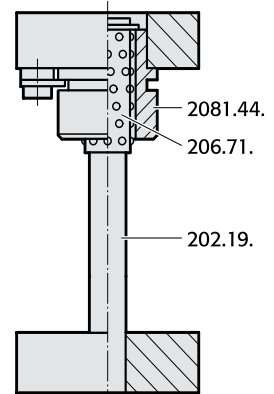

Order No (part IV)
2010.□□.□□□□.□.862.

Description:

FIBRO Standard Aluminium Die Sets offer the choice between sintered ferrite sliding guides and those of the ball bearing type to DIN/ISO. Both come with headed guide bushes. These are seated in push-fit bolster bores and retained there by screw clamps.

On request Aluminium Die Sets can also be fitted with any other FIBRO Guide Elements – for combination possibilities see page A 30.

FIBRO will furthermore supply die sets with special machining features to customers' drawings.

Ordering example see opposite fold out page.

Standard Aluminium Die Sets similar DIN 9868/ISO 11415 with stripper

FIBRO

2010.65. 2010.66.
2010.69.

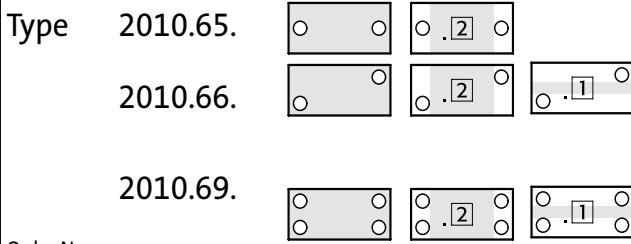

Order No
Part .I .II .III.IV .V

Type	Size	P*	Guides type	ext. dims. a ₁ × b ₁	work area a ₂ × b ₁	work area a ₁ × a ₃	C ₁ ±2	C ₂ ±2	C ₃ ±2	C ₄	C ₅	d ₁ /d ₂ × l	D	e ₁	e ₂	e ₄
2010.	.1608.1.			160 × 80	60 × 80	-	32	32	25	12	12	19/20 × 180	39	100	-	-
	.1610.1.			160 × 100	60 × 100	-	32	32	25	12	12	19/20 × 180	39	100	-	-
	.1612.1.			160 × 125	60 × 125	-	32	32	25	12	12	19/20 × 180	39	100	-	-
	.1616.1.			160 × 160	60 × 160	160 × 60	32	32	25	12	12	19/20 × 180	39	100	100	103
2010.	.2010.1.			200 × 100	70 × 100	-	40	40	25	25	25	24/25 × 200	46	120	-	-
	.2010.2.						40	32								
	.2010.3.						32	40								
	.2010.4.						32	32								
2010.	.2012.1.			200 × 125	70 × 125	-	40	40	25	25	12	24/25 × 200	46	120	-	-
	.2012.2.						40	32								
	.2012.3.						32	40								
	.2012.4.						32	32								
2010.	.2016.1.			200 × 160	70 × 160	-	40	40	25	25	12	24/25 × 200	46	120	-	-
	.2016.2.						40	32								
	.2016.3.						32	40								
	.2016.4.						32	32								
2010.	.2020.1.			200 × 200	70 × 200	200 × 70	40	40	25	25	12	24/25 × 200	46	120	120	123
	.2020.2.						40	32								
	.2020.3.						32	40								
	.2020.4.						32	32								
2010.	.2512.1.			250 × 125	120 × 125	-	40	40	25	25	12	24/25 × 200	46	170	-	-
	.2512.2.						40	32								
	.2512.3.						32	40								
	.2512.4.						32	32								
2010.	.2516.1.			250 × 160	120 × 160	-	40	40	25	25	12	24/25 × 200	46	170	-	-
	.2516.2.						40	32								
	.2516.3.						32	40								
	.2516.4.						32	32								
2010.	.2520.1.			250 × 200	120 × 200	250 × 70	40	40	25	25	12	24/25 × 200	46	170	120	173
	.2520.2.						40	32								
	.2520.3.						32	40								
	.2520.4.						32	32								
2010.	.2525.1.			250 × 250	120 × 250	250 × 120	40	40	25	25	12	24/25 × 200	46	170	170	173
	.2525.2.						40	32								
	.2525.3.						32	40								
	.2525.4.						32	32								
2010.	.3116.1.			315 × 160	165 × 160	-	50	50	32	32	12	30/32 × 224	53	225	-	-
	.3116.2.						50	40								
	.3116.3.						40	50								
	.3116.4.						40	40								
2010.	.3120.1.			315 × 200	165 × 200	315 × 50	50	50	32	32	12	30/32 × 224	53	225	110	228
	.3120.2.						50	40								
	.3120.3.						40	50								
	.3120.4.						40	40								
2010.	.3125.1.			315 × 250	165 × 250	315 × 100	50	50	32	32	12	30/32 × 224	53	225	160	228
	.3125.2.						50	40								
	.3125.3.						40	50								
	.3125.4.						40	40								
2010.	.3131.1.			315 × 315	165 × 315	315 × 165	50	50	32	32	12	30/32 × 224	53	225	225	228
	.3131.2.						50	40								
	.3131.3.						40	50								
	.3131.4.						40	40								
2010.	.4020.1.			400 × 200	250 × 200	400 × 50	50	50	32	32	12	30/32 × 224	53	310	110	313
	.4020.2.						50	40								
	.4020.3.						40	50								
	.4020.4.						40	40								
2010.	.4025.1.			400 × 250	250 × 250	400 × 100	50	50	32	32	12	30/32 × 224	53	310	160	313
	.4025.2.						50	40								
	.4025.3.						40	50								
	.4025.4.						40	40								
2010.	.4031.1.			400 × 315	250 × 315	400 × 165	50	50	32	32	12	30/32 × 224	53	310	225	313
	.4031.2.						50	40								
	.4031.3.						40	50								
	.4031.4.						40	40								

Standard Aluminium Die Sets similar DIN 9868/ISO 11415 with stripper

FIBRO

2010.65. 2010.66.
2010.69.



Order No		Part				ext. dims. $a_1 \times b_1$	work area $a_2 \times b_1$	work area $a_1 \times a_3$	c_1 ± 2	c_2 ± 2	c_3 ± 2	c_4	c_5	$d_1/d_2 \times l$	D	e_1	e_2	e_4
.I	.II	.III	.IV	.V														
Type	Size	P*	Guides type															
2010.	.4040.1.				400 × 400	250 × 400	400 × 250	50	50	32	32	12	30/32 × 224	53	310	310	313	
	.4040.2.							50	40									
	.4040.3.							40	50									
	.4040.4.							40	40									
2010.	.5025.1.				500 × 250	330 × 250	500 × 80	50	50	32	32	15	38/40 × 224	63	400	150	403	
	.5025.2.							50	40									
	.5025.3.							40	50									
	.5025.4.							40	40									
2010.	.5031.1.				500 × 315	330 × 315	500 × 145	50	50	32	32	15	38/40 × 224	63	400	215	403	
	.5031.2.							50	40									
	.5031.3.							40	50									
	.5031.4.							40	40									
2010.	.5040.1.				500 × 400	330 × 400	500 × 230	50	50	32	32	15	38/40 × 224	63	400	300	403	
	.5040.2.							50	40									
	.5040.3.							40	50									
	.5040.4.							40	40									
2010.	.5050.1.				500 × 500	330 × 500	500 × 330	50	50	32	32	15	38/40 × 224	63	400	400	403	
	.5050.2.							50	40									
	.5050.3.							40	50									
	.5050.4.							40	40									
2010.	.6331.1.				630 × 315	430 × 315	630 × 115	63	63	40	36	18	48/50 × 280	77	510	195	513	
	.6331.2.							63	50				48/50 × 280					
	.6331.3.							50	63				48/50 × 250					
	.6331.4.							50	50				48/50 × 250					
2010.	.6340.1.				630 × 400	430 × 400	630 × 200	63	63	40	36	18	48/50 × 280	77	510	280	513	
	.6340.2.							63	50				48/50 × 280					
	.6340.3.							50	63				48/50 × 250					
	.6340.4.							50	50				48/50 × 250					
2010.	.6350.1.				630 × 500	430 × 500	630 × 300	63	63	40	36	18	48/50 × 280	77	510	380	513	
	.6350.2.							63	50				48/50 × 280					
	.6350.3.							50	63				48/50 × 250					
	.6350.4.							50	50				48/50 × 250					
2010.	.6363.1.				630 × 630	430 × 630	630 × 430	63	63	40	36	18	48/50 × 280	77	510	510	513	
	.6363.2.							63	50				48/50 × 280					
	.6363.3.							50	63				48/50 × 250					
	.6363.4.							50	50				48/50 × 250					
2010.	.7140.1.				710 × 400	510 × 400	710 × 200	63	63	40	36	18	48/50 × 280	77	590	280	593	
	.7140.2.							63	50				48/50 × 280					
	.7140.3.							50	63				48/50 × 250					
	.7140.4.							50	50				48/50 × 250					
2010.	.7150.1.				710 × 500	510 × 500	710 × 300	63	63	40	36	18	48/50 × 280	77	590	380	593	
	.7150.2.							63	50				48/50 × 280					
	.7150.3.							50	63				48/50 × 250					
	.7150.4.							50	50				48/50 × 250					
2010.	.7163.1.				710 × 630	510 × 630	710 × 430	63	63	40	36	18	48/50 × 280	77	590	510	593	
	.7163.2.							63	50				48/50 × 280					
	.7163.3.							50	63				48/50 × 250					
	.7163.4.							50	50				48/50 × 250					
2010.	.8040.1.				800 × 400	600 × 400	800 × 200	63	63	40	36	18	48/50 × 280	77	680	280	683	
	.8040.2.							63	50				48/50 × 280					
	.8040.3.							50	63				48/50 × 250					
	.8040.4.							50	50				48/50 × 250					
2010.	.8050.1.				800 × 500	600 × 500	800 × 300	63	63	40	36	18	48/50 × 280	77	680	380	683	
	.8050.2.							63	50				48/50 × 280					
	.8050.3.							50	63				48/50 × 250					
	.8050.4.							50	50				48/50 × 250					
2010.	.8063.1.				800 × 630	600 × 630	800 × 430	63	63	40	36	18	48/50 × 280	77	680	510	683	
	.8063.2.							63	50				48/50 × 280					
	.8063.3.							50	63				48/50 × 250					
	.8063.4.							50	50				48/50 × 250					

*P. = thickness combination

Ordering Code (example):

Type of Die Set = 2010.65.
 Ext. dimensions = 400 × 250 = 4025.
 Combination* $c_1 = 50, c_2 = 50$ = 1.
 Guides type: headed guide bushes, ferrite = 835.
 Work area 2 = 2
 Order No = 2010.65.4025.1.835.2

Advisory: Ordering Code

Hole pattern for the screw clamps depends on positioning of working surface, determined by part V (five) of the Order No, for example: 2010.69.2520.4.865.1 
 .2 

FIBRO

2010.65. 2010.67.
2010.66. 2010.69.

Standard Aluminium Die Sets similar DIN 9868/ISO 11415 without stripper

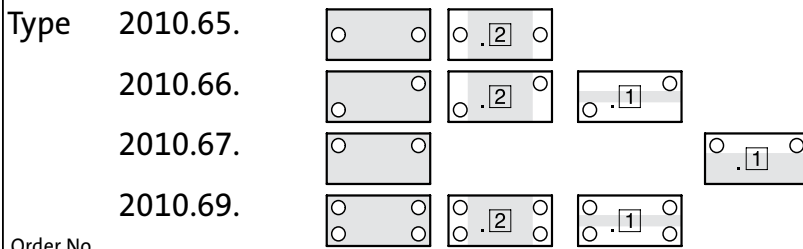

Order No

Part .I .II .III,IV .V

Type	Size	P*	Guides type	ext. dims. $a_1 \times b_1$	work area $a_2 \times b_1$	work area $a_1 \times a_3$	work area $a_1 \times a_4$	c_1 ± 2	c_2 ± 2	c_4 S	c_4 K	$d_1/d_2 \times l$	D	e_1	e_2	e_3	e_4
2010.	.1608.1.			160 × 80	60 × 80	-	-	32	32	20	36	19/20 × 160	39	100	-	-	-
	.1610.1.			160 × 100	60 × 100	-	160 × 50	32	32	20	36	19/20 × 160	39	100	-	70	-
	.1612.1.			160 × 125	60 × 125	-	160 × 75	32	32	20	36	19/20 × 160	39	100	-	95	-
	.1616.1.			160 × 160	60 × 160	160 × 60	160 × 110	32	32	20	36	19/20 × 160	39	100	100	130	103
2010.	.2010.1.			200 × 100	70 × 100	-	-	40	40	36	56	24/25 × 180	46	120	-	-	-
	.2010.2.							40	32								
	.2010.3.							32	40								
	.2010.4.							32	32								
2010.	.2012.1.			200 × 125	70 × 125	-	200 × 60	40	40	36	56	24/25 × 180	46	120	-	85	-
	.2012.2.							40	32								
	.2012.3.							32	40								
	.2012.4.							32	32								
2010.	.2016.1.			200 × 160	70 × 160	-	200 × 95	40	40	36	56	24/25 × 180	46	120	-	120	-
	.2016.2.							40	32								
	.2016.3.							32	40								
	.2016.4.							32	32								
2010.	.2020.1.			200 × 200	70 × 200	200 × 70	200 × 135	40	40	36	56	24/25 × 180	46	120	120	160	123
	.2020.2.							40	32								
	.2020.3.							32	40								
	.2020.4.							32	32								
2010.	.2512.1.			250 × 125	120 × 125	-	250 × 60	40	40	36	56	24/25 × 180	46	170	-	85	-
	.2512.2.							40	32								
	.2512.3.							32	40								
	.2512.4.							32	32								
2010.	.2516.1.			250 × 160	120 × 160	-	250 × 95	40	40	36	56	24/25 × 180	46	170	-	120	-
	.2516.2.							40	32								
	.2516.3.							32	40								
	.2516.4.							32	32								
2010.	.2520.1.			250 × 200	120 × 200	250 × 70	250 × 135	40	40	36	56	24/25 × 180	46	170	120	160	173
	.2520.2.							40	32								
	.2520.3.							32	40								
	.2520.4.							32	32								
2010.	.2525.1.			250 × 250	120 × 250	250 × 120	250 × 185	40	40	36	56	24/25 × 180	46	170	170	210	173
	.2525.2.							40	32								
	.2525.3.							32	40								
	.2525.4.							32	32								
2010.	.3116.1.			315 × 160	165 × 160	-	315 × 85	50	50	45	63	30/32 × 200	53	225	-	115	-
	.3116.2.							50	40								
	.3116.3.							40	50								
	.3116.4.							40	40								
2010.	.3120.1.			315 × 200	165 × 200	315 × 50	315 × 125	50	50	45	63	30/32 × 200	53	225	110	155	228
	.3120.2.							50	40								
	.3120.3.							40	50								
	.3120.4.							40	40								
2010.	.3125.1.			315 × 250	165 × 250	315 × 100	315 × 175	50	50	45	63	30/32 × 200	53	225	160	205	228
	.3125.2.							50	40								
	.3125.3.							40	50								
	.3125.4.							40	40								
2010.	.3131.1.			315 × 315	165 × 315	315 × 165	315 × 240	50	50	45	63	30/32 × 200	53	225	225	270	228
	.3131.2.							50	40								
	.3131.3.							40	50								
	.3131.4.							40	40								
2010.	.4020.1.			400 × 200	250 × 200	400 × 50	400 × 125	50	50	45	63	30/32 × 200	53	310	110	155	313
	.4020.2.							50	40								
	.4020.3.							40	50								
	.4020.4.							40	40								
2010.	.4025.1.			400 × 250	250 × 250	400 × 100	400 × 175	50	50	45	63	30/32 × 200	53	310	160	205	313
	.4025.2.							50	40								
	.4025.3.							40	50								
	.4025.4.							40	40								
2010.	.4031.1.			400 × 315	250 × 315	400 × 165	400 × 240	50	50	45	63	30/32 × 200	53	310	225	270	313
	.4031.2.							50	40								
	.4031.3.							40	50								
	.4031.4.							40	40								

Standard Aluminium Die Sets similar DIN 9868/ISO 11415 with stripper

FIBRO

2010.65. 2010.66.
2010.69.

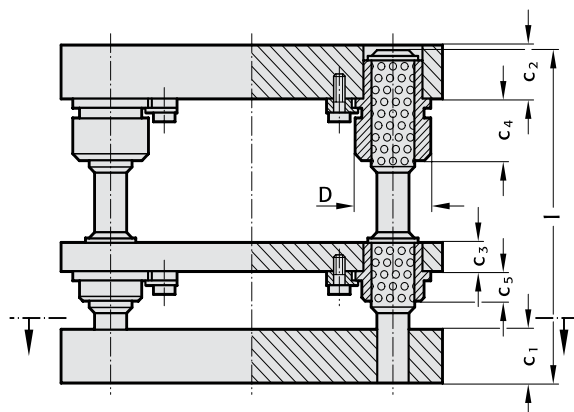
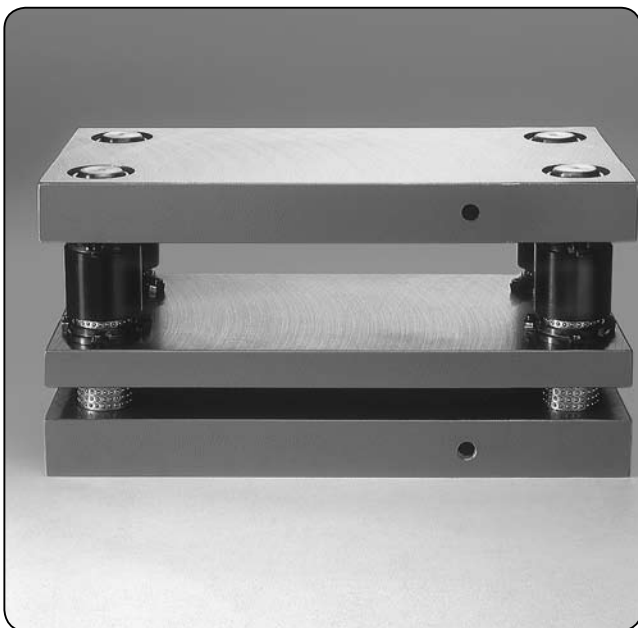

2010.65.

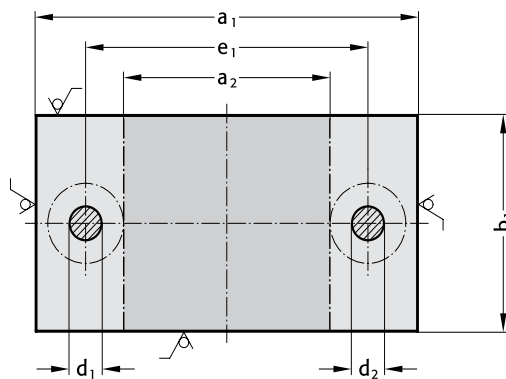

2010.66.

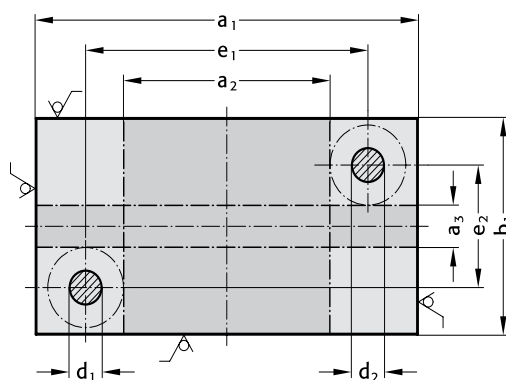

2010.69.

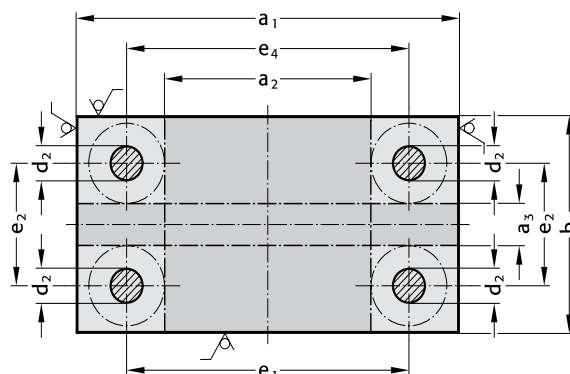

Standard Guide Systems

Headed Sintered Ferrite Bushes, carbonitrided

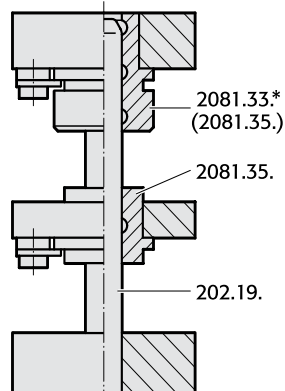

Order No (part IV)
2010.□□.□□□□.□.835.

Headed Ball Bearing Bushes

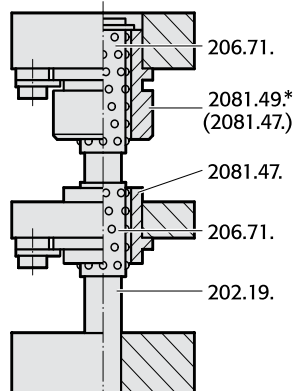

Order No (part IV)
2010.□□.□□□□.□.865.

* up to size 2010.□□.1616. = 2081.35./2081.47.

Description:

FIBRO Standard All-Steel Die Sets offer the choice between sintered ferrite sliding guides and those of the ball bearing type to DIN-ISO. Both come with headed guide bushes. These are seated in push-fit bolster bores and retained there by screw clamps.

On request, All-Steel Die Sets can also be fitted with any other FIBRO Guide Elements – for combination possibilities see page A 30.

FIBRO will furthermore supply die sets with special machining features to customers' drawings.

Ordering example see opposite fold out page.

**Die Set Press Units
with/without guided bolster**

2011.45.
2011.49.

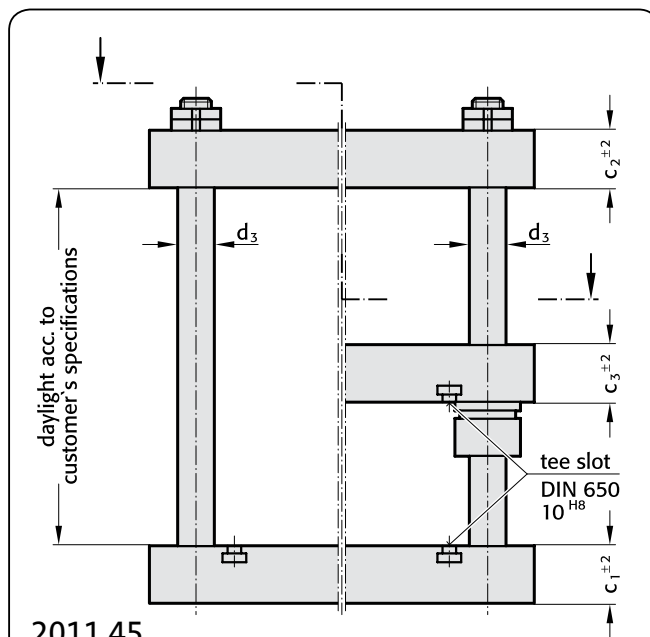

2011.49.

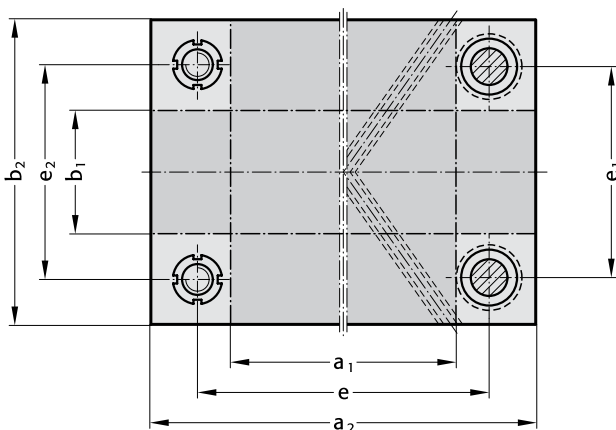

2011.45.

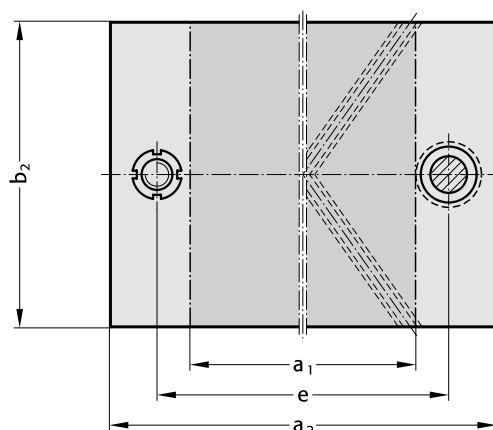

Order number system:

2011.4□.4031.□□□.□□□.1

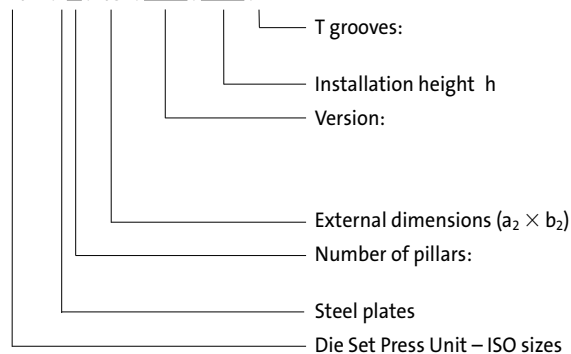

Coupling spigots and -holders between cylinder and tool: see page A 44.

.0 = without
.1 = in lower part and intermediate plate

000. = without guide bolster
001. = without guide bolster – tension rod not hardened
831. = guide bolster with plain bearing
862. = guide bolster with ball bearing guide
40: a₂ = 400 mm; 31: b₂ = 315 mm
5. = two guide pillars
9. = four guide pillars

2011.

Order No	work area		max. press thrust kN	work area					max. press thrust				
	a ₁ × b ₂	a ₂ × b ₁		a ₂	b ₂	c ₁	c ₂	c ₃	d ₃	e	e ₁	e ₂	
2011.	.2020.	86 × 200	200 × 65	20	200	200	32	32	32	25	132	132	129
	.2520.	136 × 200	250 × 64		250	200	32	32	32	25	182	132	129
	.2525.	120 × 250	250 × 100	40	250	250	40	40	40	32	174	174	171
	.3125.	185 × 250	315 × 100		315	250	40	40	40	32	239	174	171
	.3131.	185 × 315	315 × 165		315	315	40	40	40	32	239	239	236
	.4031.	270 × 315	400 × 165	80	400	315	50	50	50	32	324	239	236
	.4040.	270 × 400	400 × 250		400	400	50	50	50	32	324	324	321

FIBRO

201.145.
201.149.

Die Set Press Units with guided top bolster manual actuation

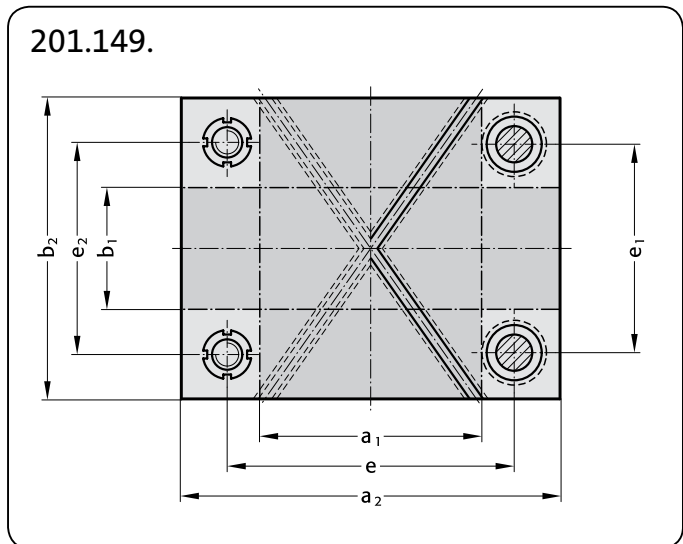
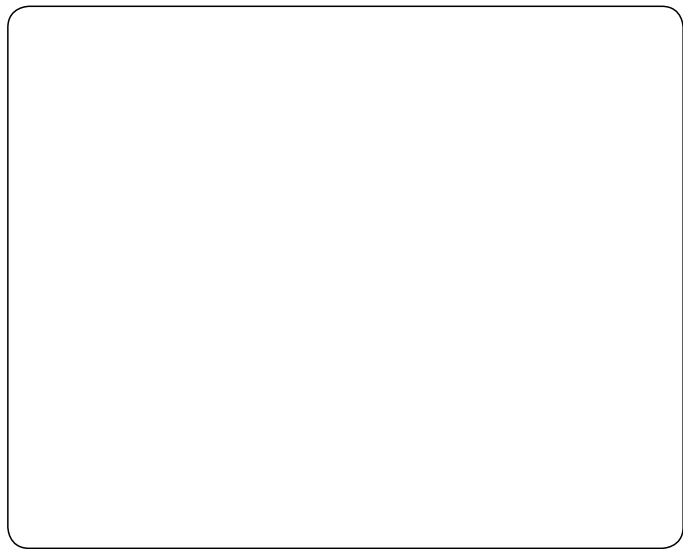
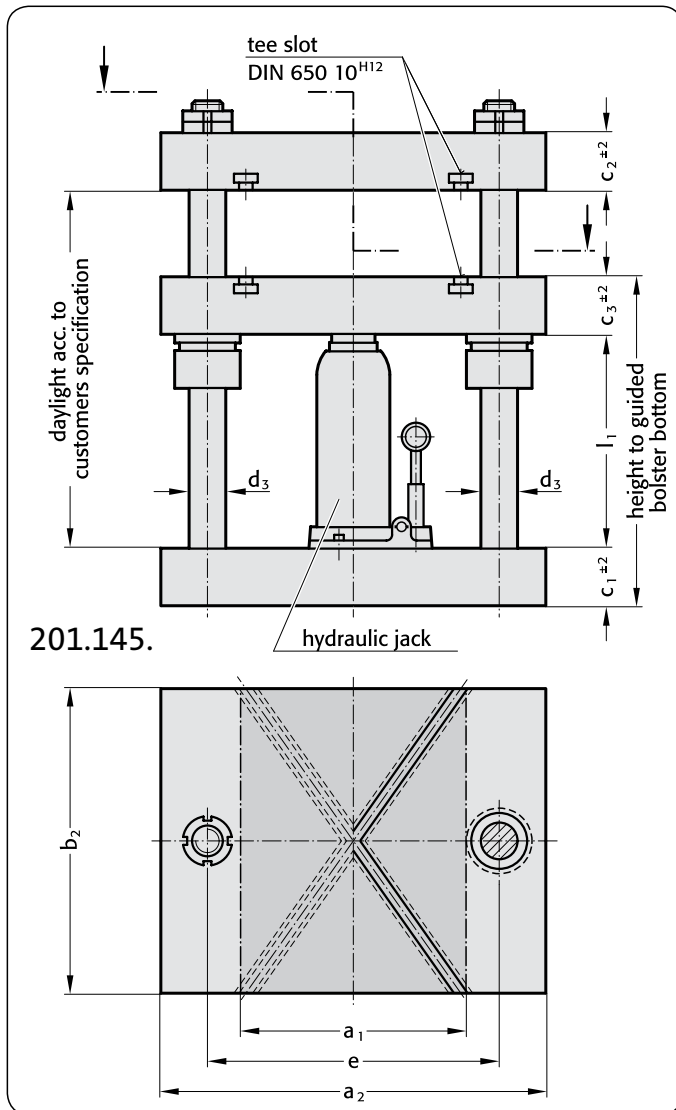

Order number system:

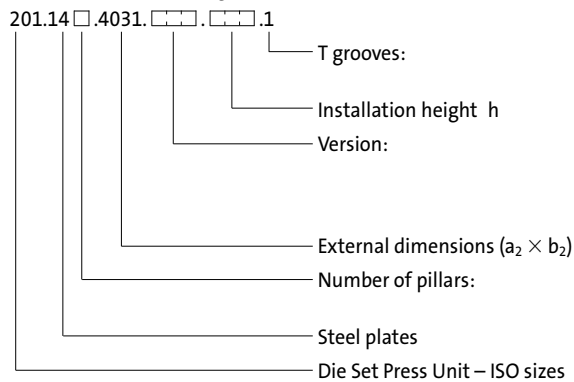

Execution: Headed guide bushes, hydraulic jack.

- .0 = without
- .1 = in top bolster and intermediate plate
- 831. = guide bolster with plain bearing
- 862. = guide bolster with ball bearing guide
- 40: $a_2 = 400$ mm; 31: $b_2 = 315$ mm
- 5. = two guide pillars
- 9. = four guide pillars

201.

Order No	work area $a_1 \times b_2$	work area $a_2 \times b_1$	max. press thrust kN	max. stroke										
				a_2	b_2	c_1	c_2	c_3	d_3	e	e_1	e_2	l_1	stroke
201.14.0.4031.0.0.0.1	86 × 200	200 × 65	20	200	200	32	32	32	25	132	132	129	180	130
201.14.0.2520.0.0.0.1	136 × 200	250 × 64	20	250	200	32	32	32	25	182	132	129		
201.14.0.2525.0.0.0.1	120 × 250	250 × 100	40	250	250	40	40	40	32	174	174	171		
201.14.0.3125.0.0.0.1	185 × 250	315 × 100	40	315	250	40	40	40	32	239	174	171	200	130
201.14.0.3131.0.0.0.1	185 × 315	315 × 165	40	315	315	40	40	40	32	239	239	236		
201.14.0.4031.0.0.0.1	270 × 315	400 × 165	80	400	315	50	50	50	32	324	239	236	245	160
201.14.0.4040.0.0.0.1	270 × 400	400 × 250	80	400	400	50	50	50	32	324	324	321		

Die Set Press Units-Accessories
Coupling Spigot Holders
Coupling Spigots

FIBRO

212.16.1.

212.11. 212.15.

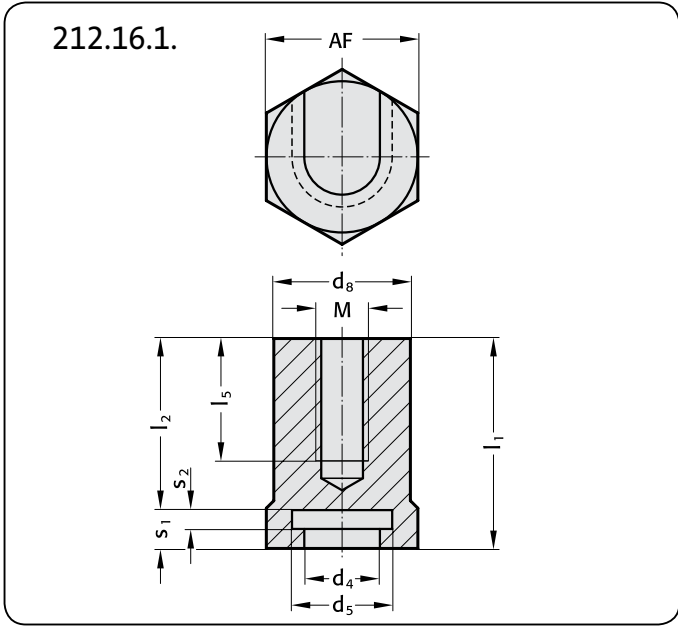

212.16.1. Coupling Spigot Holders

Order No	d ₄	d ₅	d ₈	SW	l ₁	l ₂	l ₅	M	s ₁	s ₂
212.16.1.026	26	33	45	50	70	57,4	*	*	12,6	7
033	33	49	60	65	86	67,4	*	*	18,6	10

* upon customer's specification

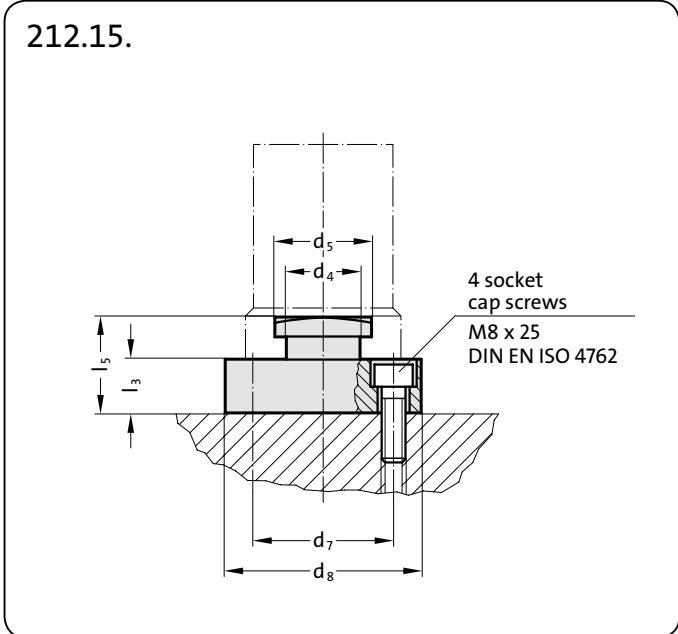
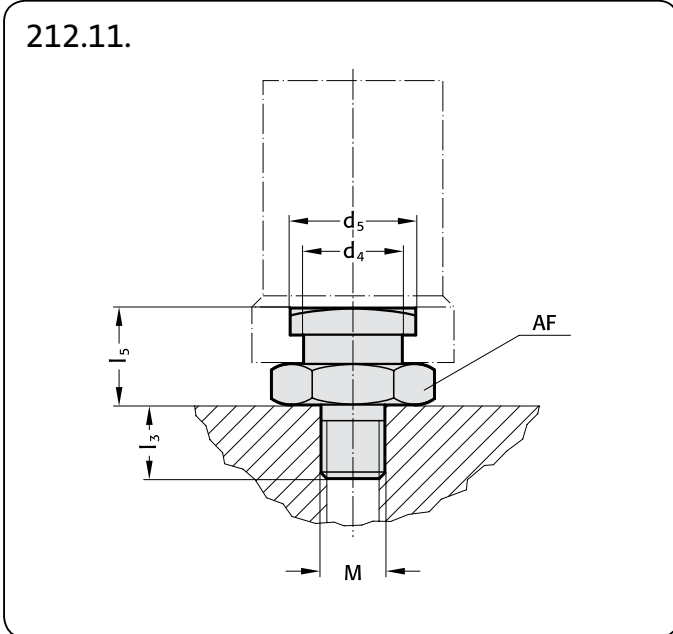

212.11. Coupling Spigots

Order No	M	d ₄	d ₅	l ₃	l ₅	SW
212.11.016	M16 × 1.5	25	32	18	23	36
030	M30 × 2	32	48	30	43	60

212.15. Coupling Spigots

Order No	d ₄	d ₅	d ₈	d ₇	l ₃	l ₅
212.15.063	25	32	63	46	18	31
080	32	48	80	63	18	37

Special Die Sets (All-Steel)
to Customers, Specifications

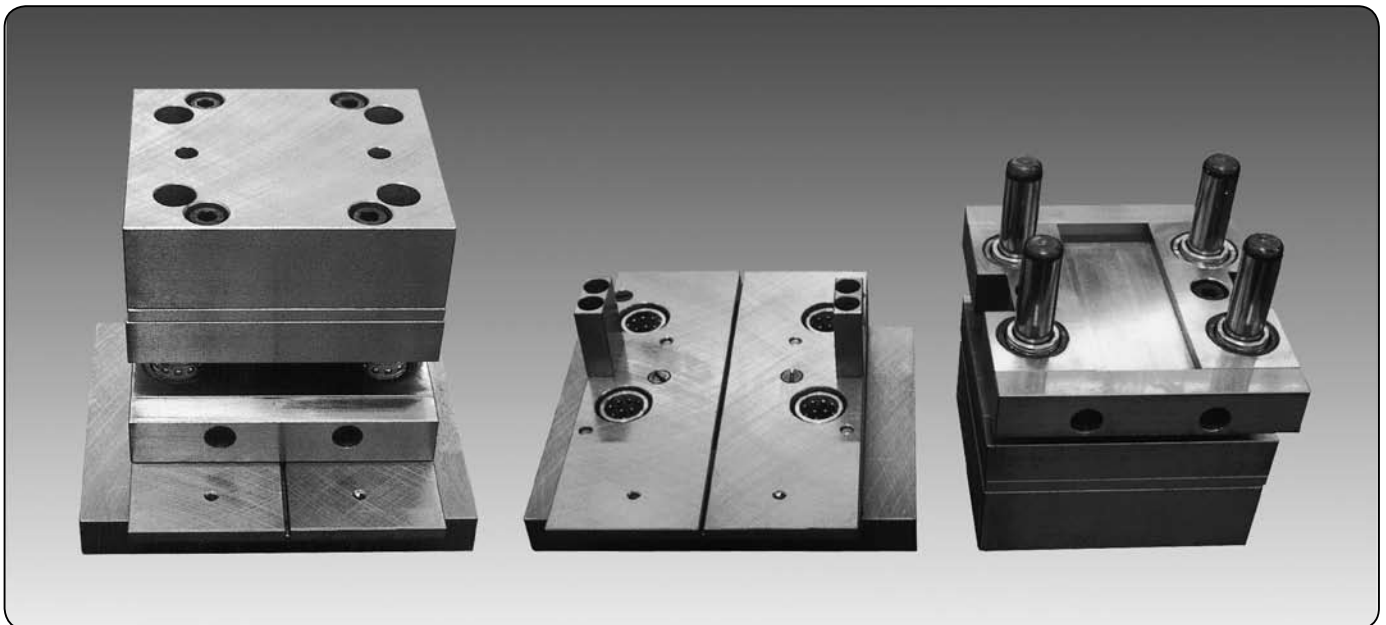
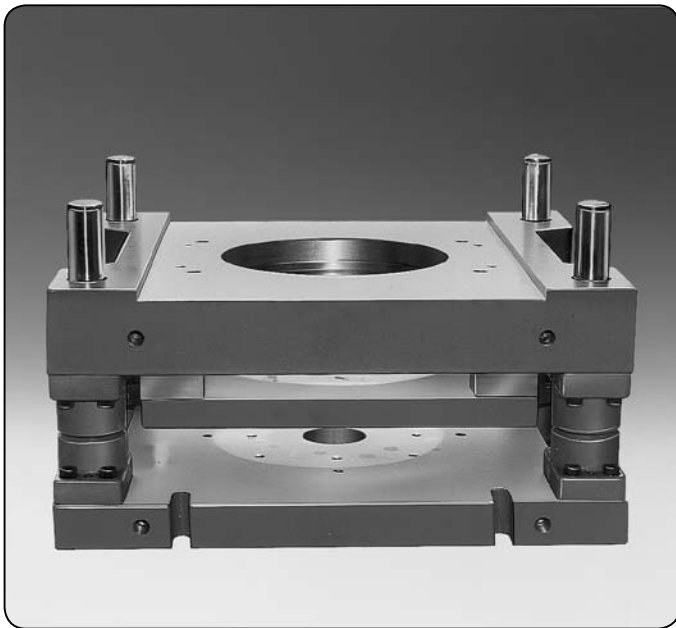
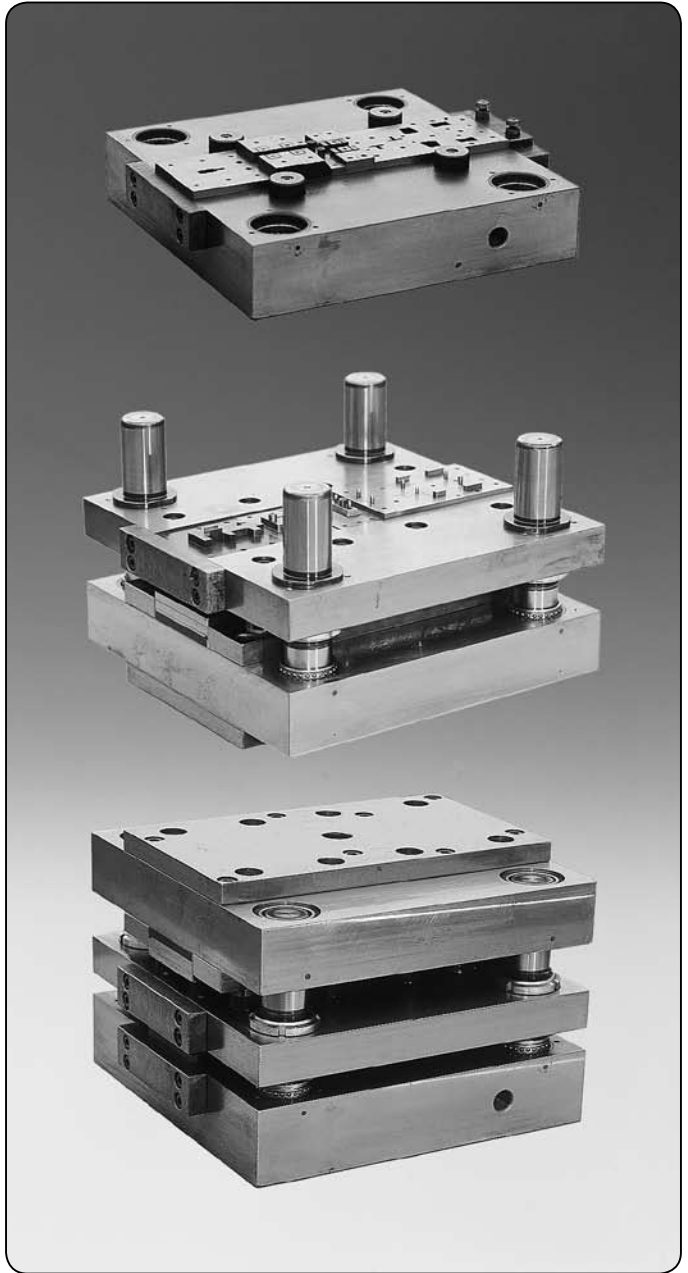

Special Die Sets (All-Steel)
to Customers, Specifications

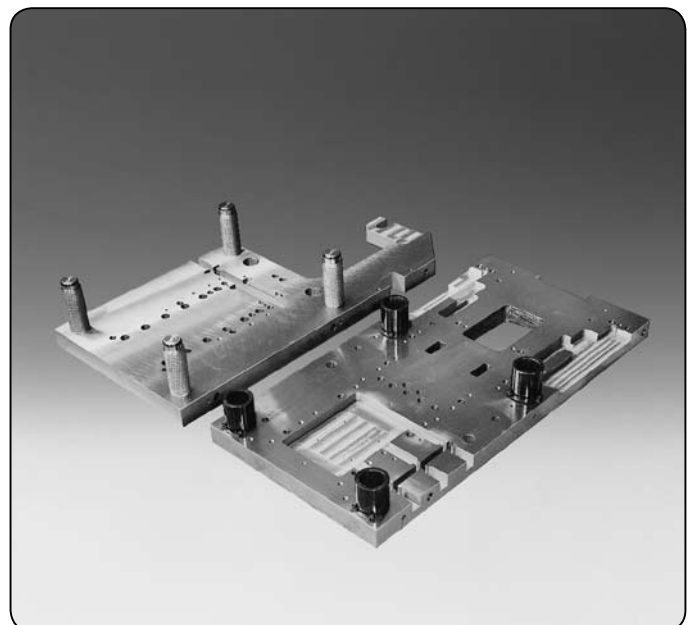
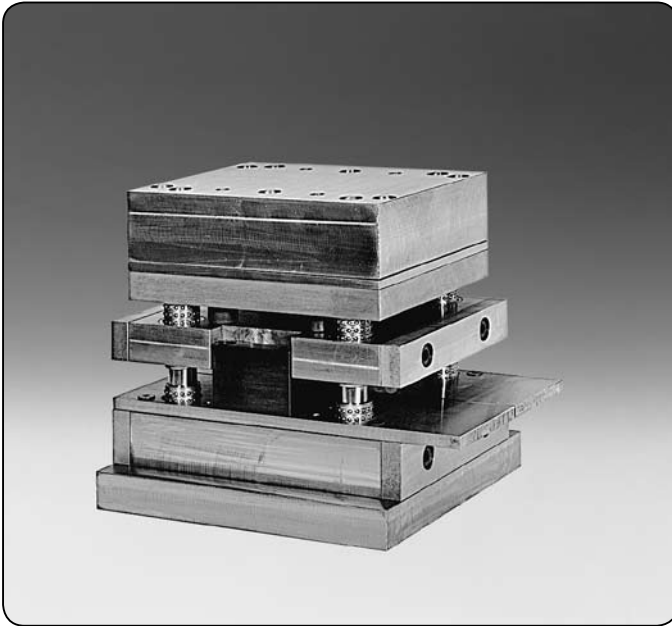

Special Die Sets (All-Steel)
to Customers, Specifications

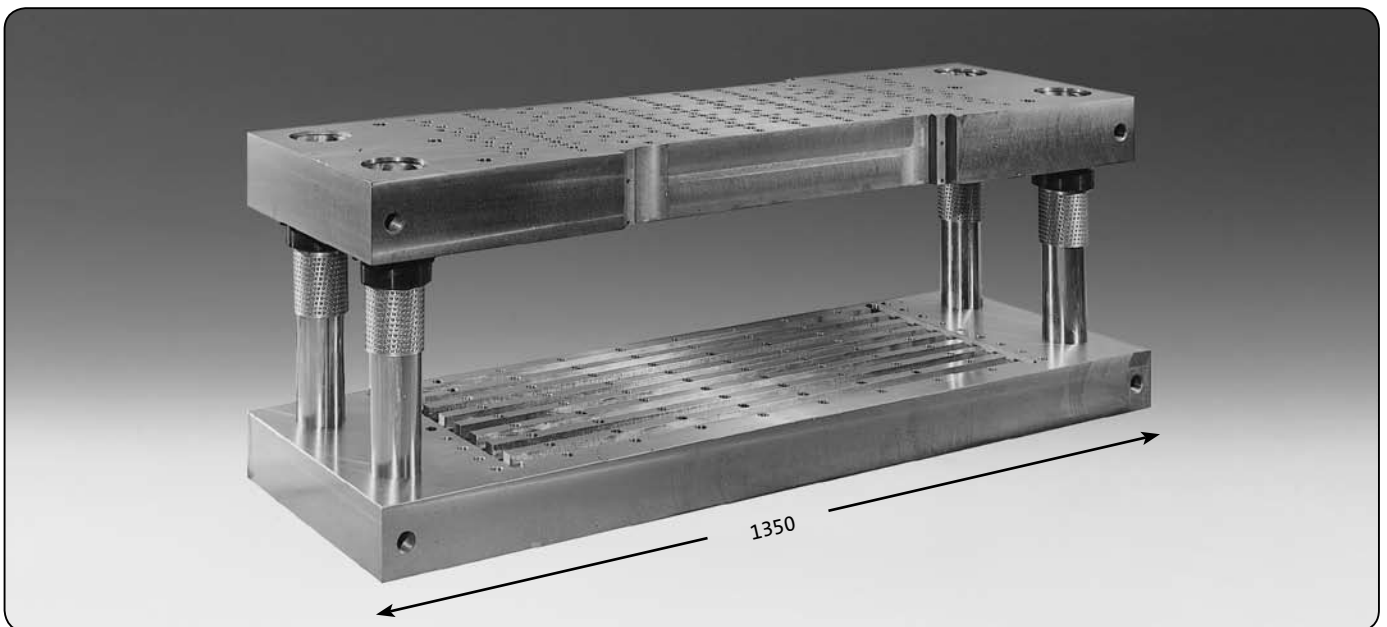
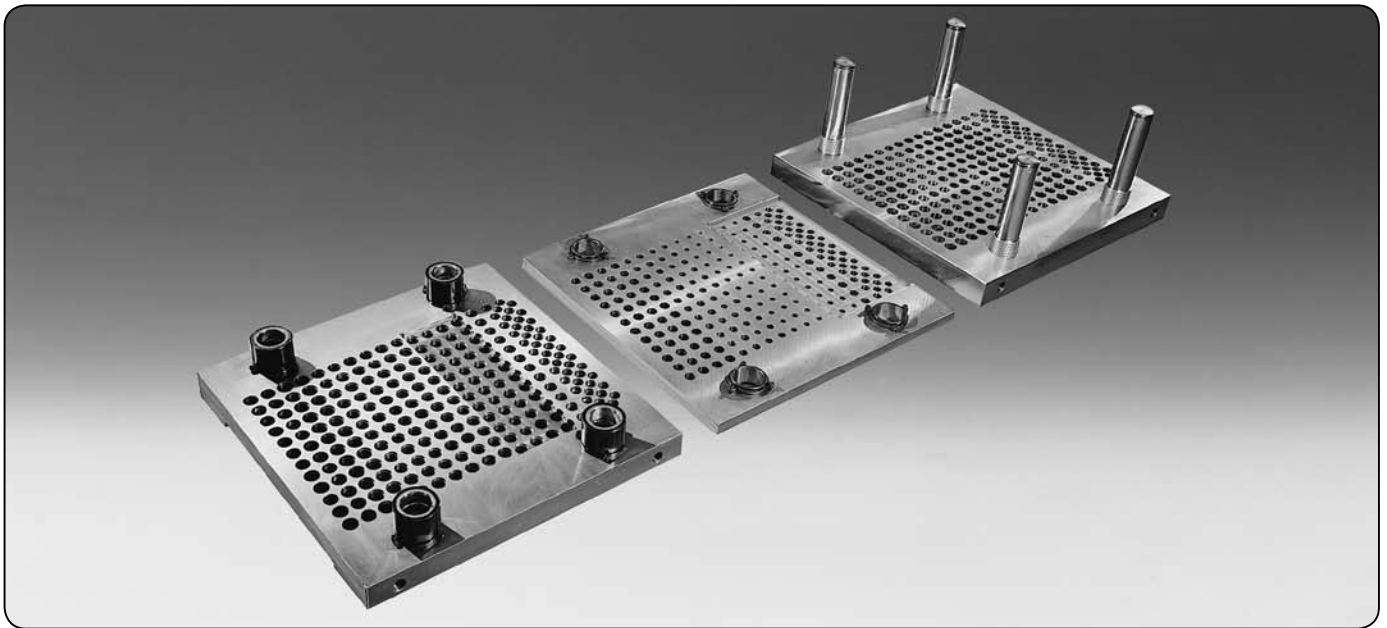
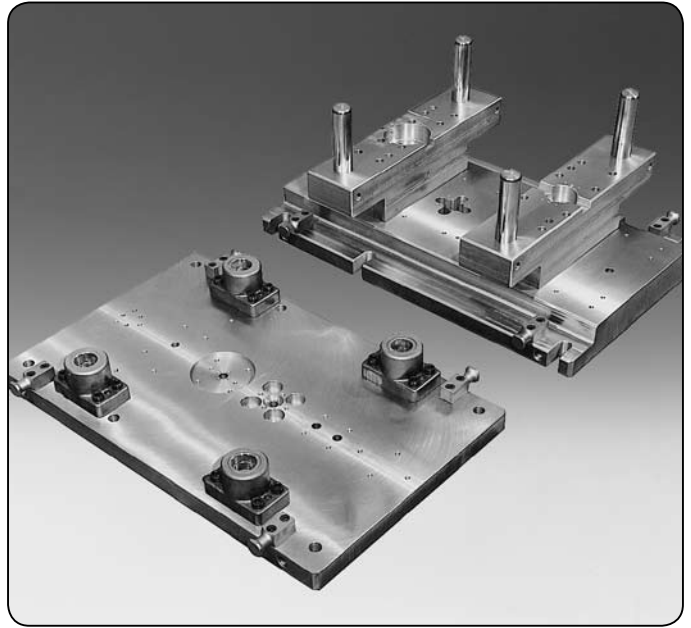
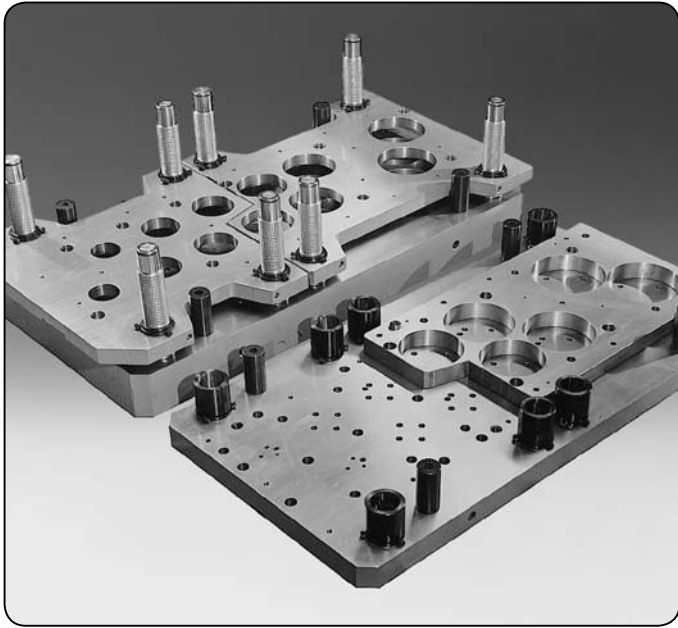

Special Die Sets (All-Steel)
to Customers, Specifications

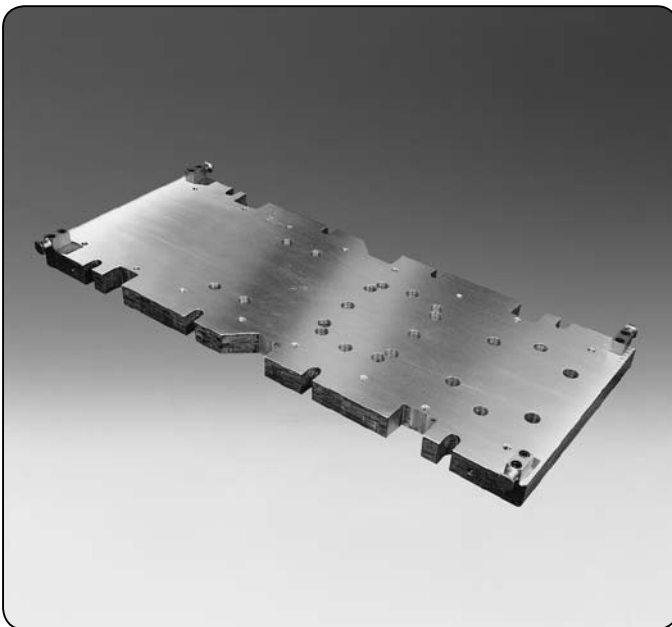
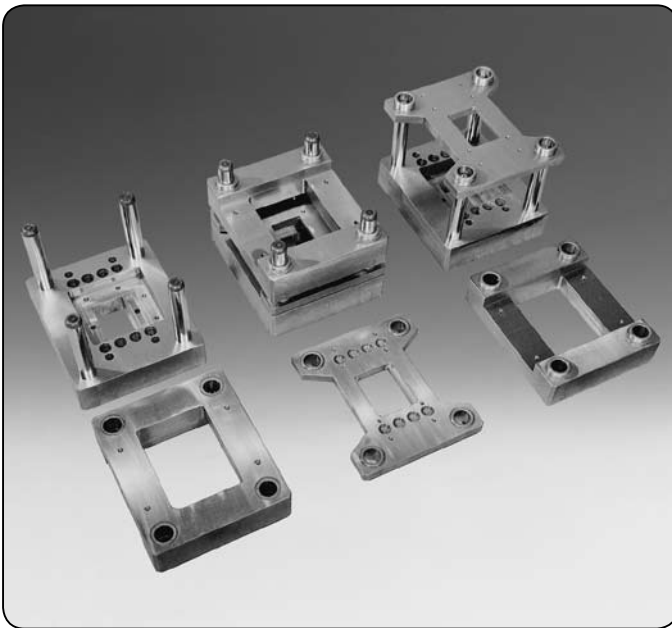
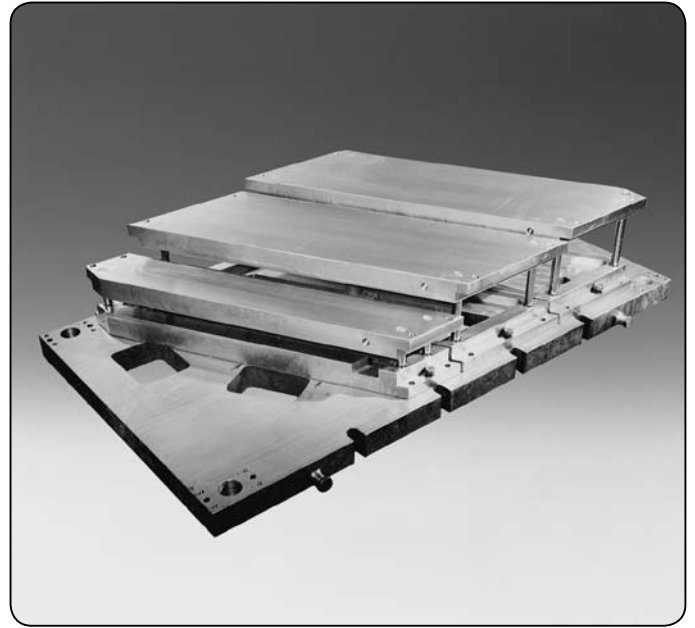
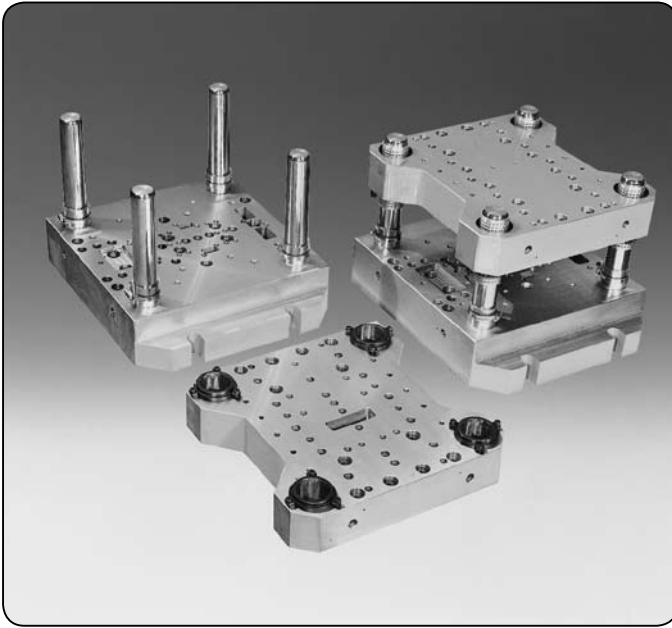



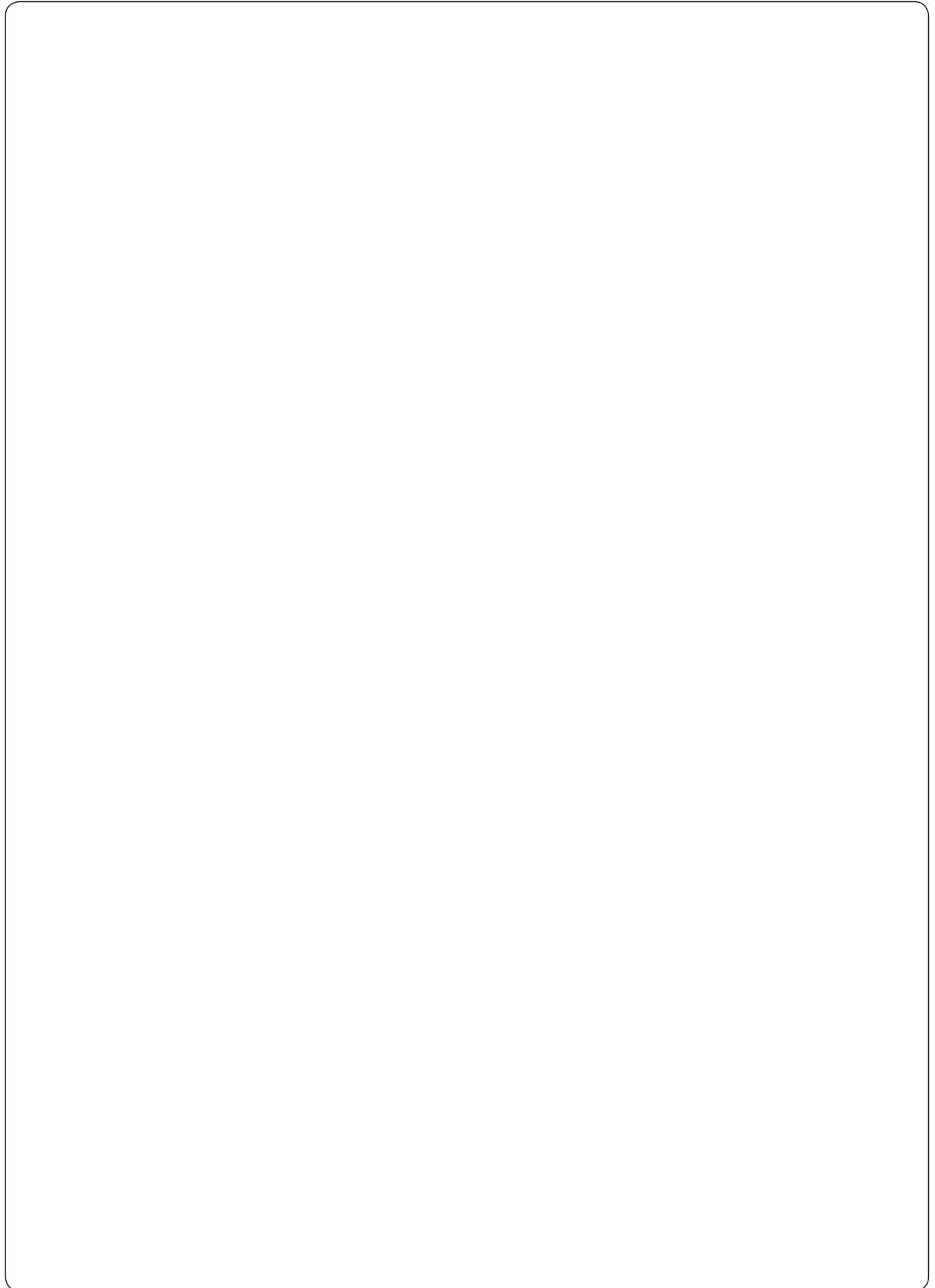

FIBRO Progression Lamination Die Set Units

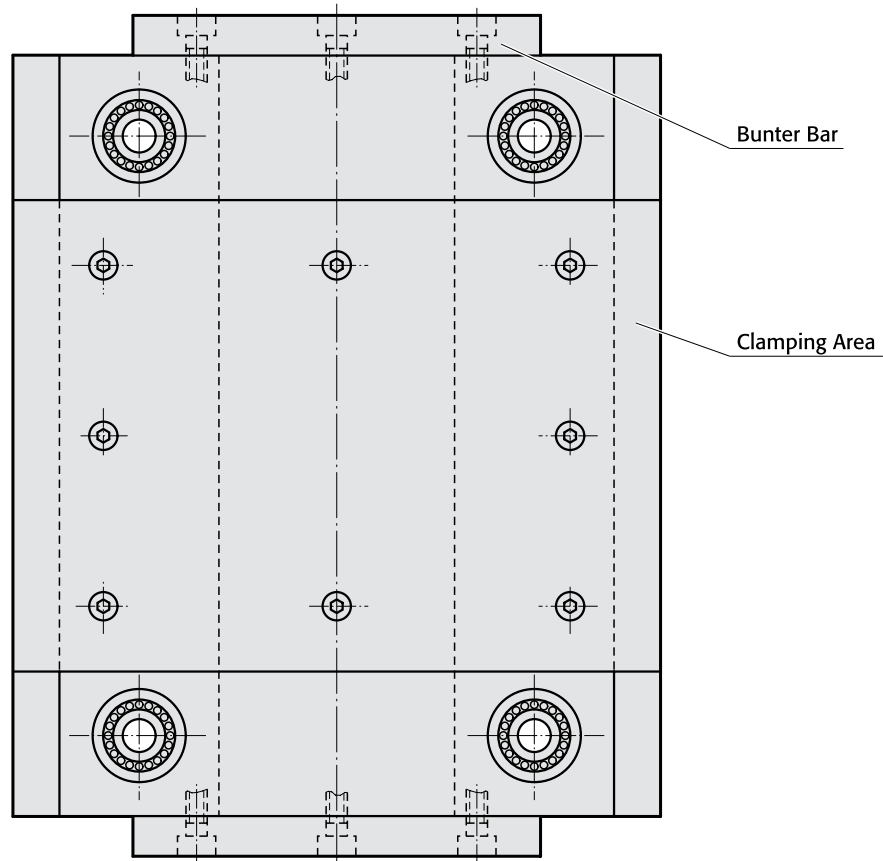
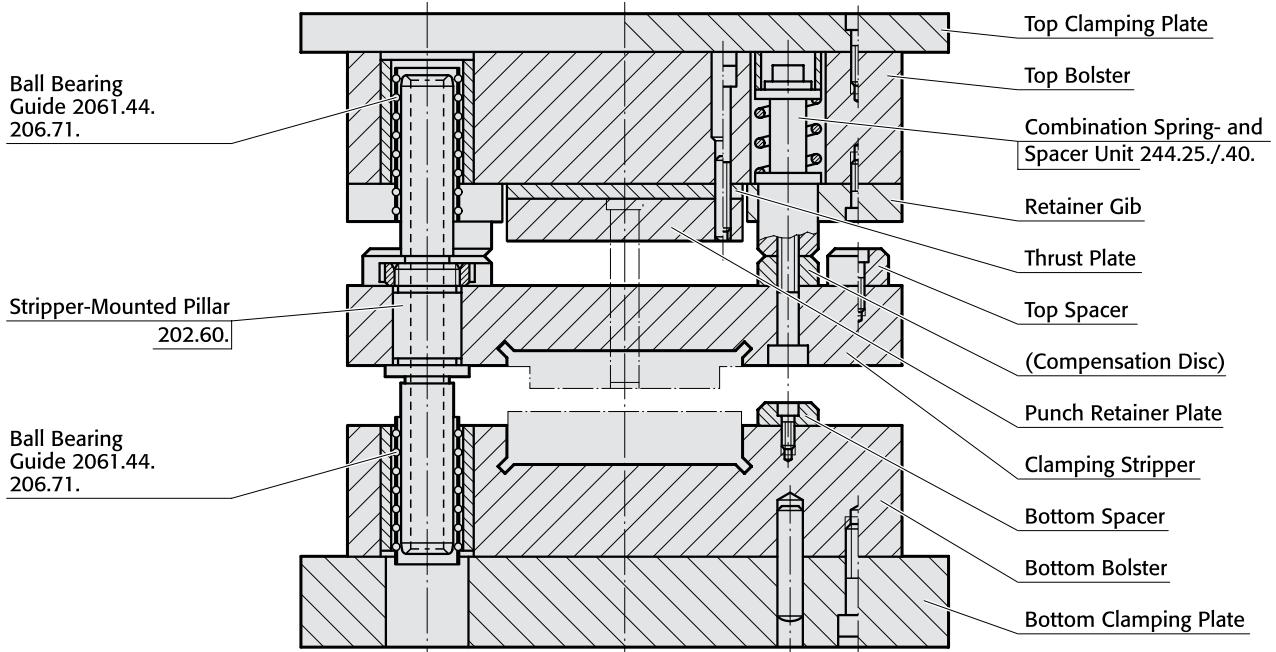

201.50.

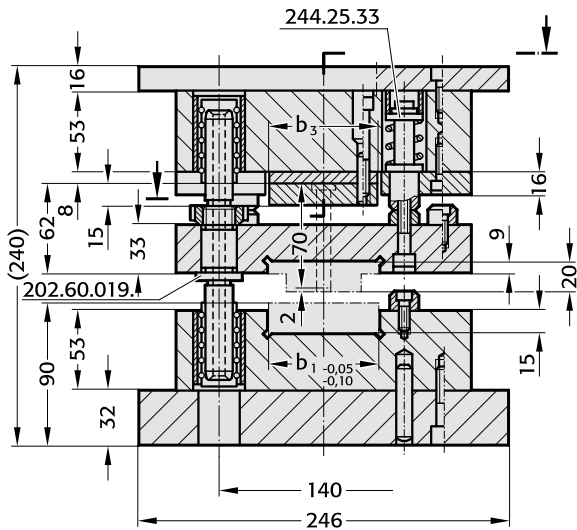

* For the sizes 201.50.2520 and 3020 guide pillars 202.60.025

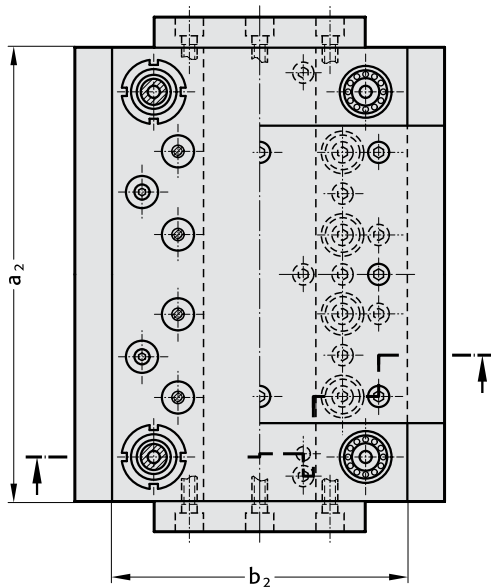

Execution

(mounting of top bolster to ram of press)

201.50. [] . [] . [] .1 201.50. [] . [] . [] .2
with projecting top clamping plate with threaded hole in top clamping plate, for threaded shank

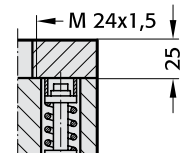
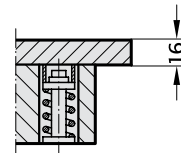

201.50. [] . [] . [] .3 201.50. [] . [] . [] .4
with threaded hole in top bolster, for threaded shank with clamping pockets milled in top bolster

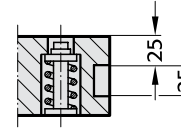
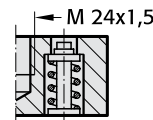

Guide Elements

Ball Bearing Guides

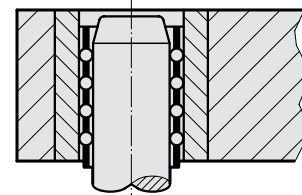

Width of slot b_1 to be determined by customer!

2D-CAD data are available on request for each Die Set Unit. The designer need only draw the active die elements. Prints can be taken from this master.

Note: Die daylight and strip height can be reduced by up to 3 mm through a reduction in the thickness of the Bottom Clamping Plate.

201.50.

Order No	Spring type	ext. dims.	Comb. spring+ spacer	max. spring compression (without pre load) (mm)	spring preload (mm)	preloading in N (per spring unit)			spring coefficient "c" (N)								
						241...	241. [] . [] .25.032	241. [] . [] .25.032	241. [] . [] .25.032	241. [] . [] .25.032	241. [] . [] .25.032						
Type	Size	$a_2 \times b_2$	b_1 max.	b_3	14	15	16	17	14	15	16	17					
201.50.1320.	[] . [] . []	126 × 196	40	4	40	6,0	6,0	5,0	3	241	354	891	-	80,3	118,1	297	-
	1620.	[] . [] . []	50	4	50												
	2020.	[] . [] . []	60	6	60												
	2520.	[] . [] . []	75	8	75												
	3020.	[] . [] . []	75	8	75												

Ordering Code (example):

Die Set Unit	=	201.50.
$a_2 \times b_2 = 296 \times 196$	=	3020.
$b_1 = 75$ mm	=	075.
Springs (type) 241.15.	=	15.
With projecting top clamping plate	=	1
Order No	=	201.50.3020.075.15.1

Die Set Units 201.50. can also be supplied in special sizes as well as special executions, acc. to customers' specifications.

201.50.

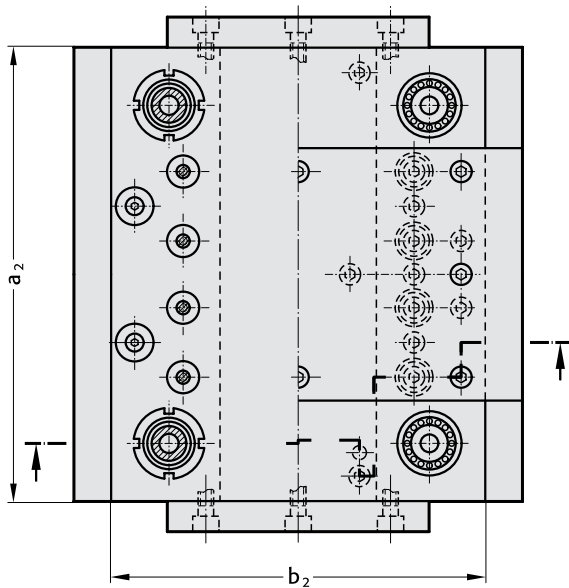
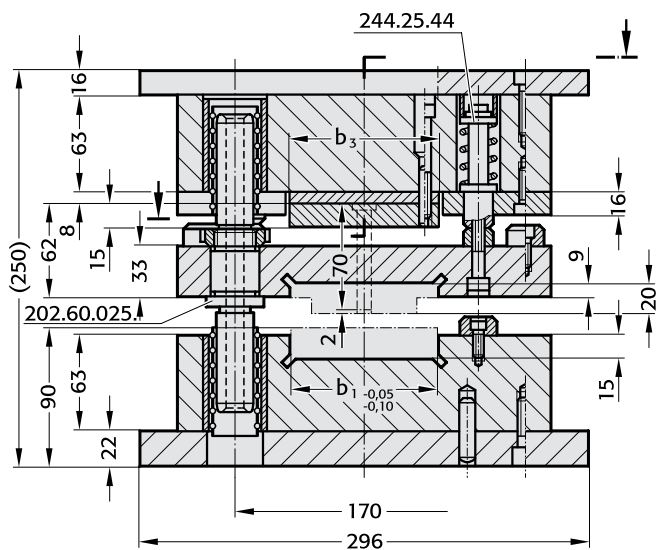

Execution

(mounting of top bolster to ram of press)

201.50. [] . [] . [] .1 201.50. [] . [] . [] .2
with projecting top clamping plate with threaded hole in top clamping plate, for threaded shank

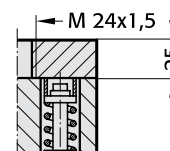
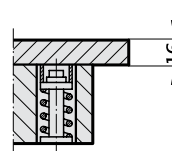

201.50. [] . [] . [] .3 201.50. [] . [] . [] .4
with threaded hole in top bolster, for threaded shank with clamping pockets milled in top bolster

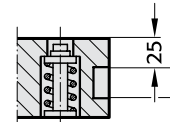
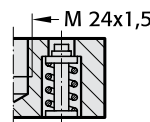

Guide Elements

Ball Bearing Guides

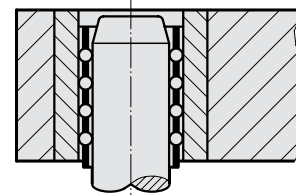

Width of slot b_1 to be determined by customer!

2D-CAD data are available on request for each Die Set Unit. The designer need only draw the active die elements. Prints can be taken from this master.

Note: Die daylight and strip height can be reduced by up to 16 mm through a reduction in the thickness of the Bottom Clamping Plate.

201.50.

Order No	Spring type	ext. dimensions $a_2 \times b_2$	b_1 max.	Comb. spring+ spacer unit	b_3	max. spring compression (without preload) (mm)				spring preload (mm)	preloading in N (per spring unit) 241. [] . [] .25.045				spring coefficient "c" (N) 241. [] . [] .25.045			
						14	15	16	17		241...	14	15	16	17	14	15	16
201.50.1625.	[] . [] . [] . []	156 × 246	60	4	60	8,0	8,0	7,8	5,4	4	212	323	748	977	53	80,8	187	244,2
2025.	[] . [] . [] . []	196 × 246	75	6	75													
2525.	[] . [] . [] . []	246 × 246	90	8	90													
3025.	[] . [] . [] . []	296 × 246	100	8	100													
3525.	[] . [] . [] . []	346 × 246	100	10	100													

Ordering Code (example):

Die Set Unit	=	201.50.
$a_2 \times b_2 = 296 \times 246$	=	3025.
$b_1 = 100$ mm	=	100.
Springs (type) 241.15.	=	15.
With projecting top clamping plate	=	1
Order No	=	201.50.3025.100.15.1

Die Set Units 201.50. can also be supplied in special sizes as well as special executions, acc. to customers' specifications.

FIBRO Progression/
Lamination Die Set Units

201.50.

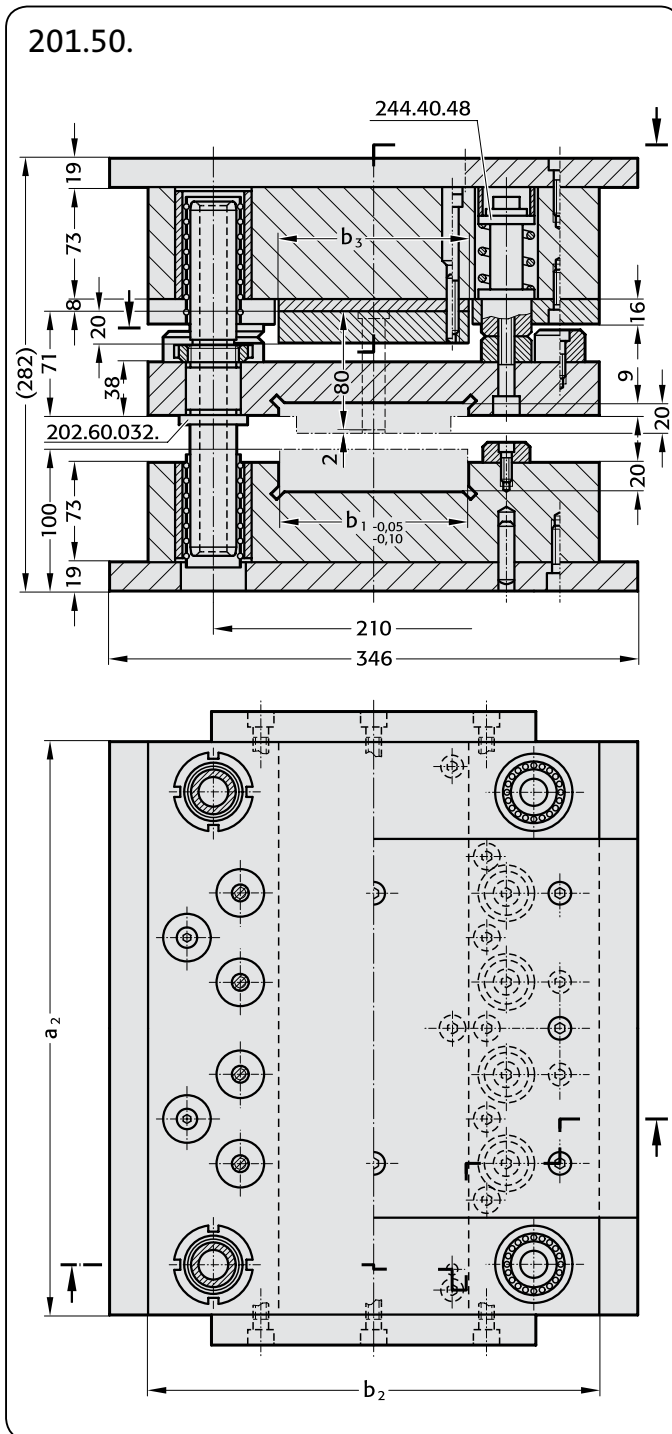

Executions

(mounting of top bolster to ram of press)

201.50. [] . [] . [] .1 201.50. [] . [] . [] .2
with projecting top clamping plate with threaded hole in top clamping plate, for threaded shank

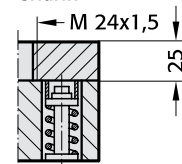
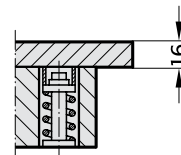

201.50. [] . [] . [] .3 201.50. [] . [] . [] .4
with threaded hole in top bolster, for threaded shank with clamping pockets milled in top bolster

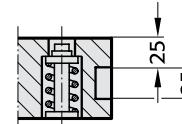
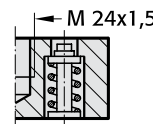

Guide Elements

Ball Bearing Guides

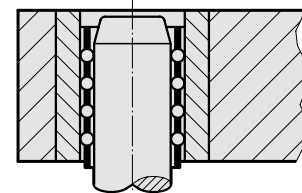

Width of slot b_1 to be determined by customer!

2D-CAD data are available on request for each Die Set Unit. The designer need only draw the active die elements. Prints can be taken from this master.

Note: Die daylight and strip height can be reduced by up to 16 mm through a reduction in the thickness of the Bottom Clamping Plate.

201.50.

Order No	Spring type	ext. dimensions $a_2 \times b_2$	b_1 max.	Comb. spring+ spacer unit.	b_3	max.spring compression (without preload) (mm)				preloading in N (per spring unit)				Spring coefficient "c" (N)				
						241...	spring preload (mm)	14	15	16	17	241...40.050	241...40.050	14	15	16	17	
201.50.2030. [] . [] . []		196 × 296	75	4	75	7,0	7,0	5,0	4,2	8	736	1432	2800	5027	92	179	350	628,4
2530. [] . [] . []		246 × 296	100	6	100													
3030. [] . [] . []		296 × 296	100	8	100													
3530. [] . [] . []		346 × 296	125	8	125													
4030. [] . [] . []		396 × 296	125	8	125													

Ordering Code (example):

Die Set Unit	=	201.50.
$a_2 \times b_2 = 296 \times 296$	=	3030.
$b_1 = 100$ mm	=	100.
Springs (type) 241.15.	=	15.
With projecting top clamping plate	=	1
Order No	=	201.50.3030.100.15.1

Die Set Units 201.50. can also be supplied in special sizes as well as special executions, acc. to customers' specifications.

Die Set Units for Progression/Lamination Dies

The accuracy of a stamping die starts with the die set! When we designed these new units, special attention was paid to the stability and load capacity of the guide pillars.

The eventual introduction of the stripper-mounted pillar in its present form brought an eightfold increase in transverse load-carrying capacity relative to conventional pillars; under the same radial force, deflection is reduced to one-eighth.

While modern high-speed presses have made ball bearing guides all but mandatory, the limited load capacity of these bearings remains a disadvantage, calling for generous nominal pillar diameters and the use of more than two guide bearings.

Considerable forces of inertia are encountered during the reversal of stroking motion at speeds in excess of 500 SPM. In order to keep these harmful forces to a minimum, FIBRO Stripper-Mounted Pillars are provided with hollow cores.

Considerations such as these formed the basis for the development of our new die set units with stripper-mounted pillars – a concept that has resulted in greatly improved accuracy, overall stability and speed capacity.

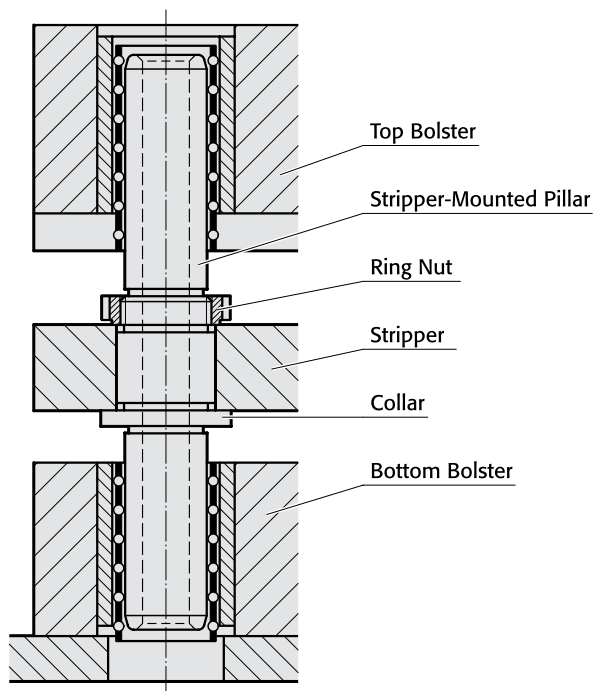

Combination Spring/Spacer Units

Strippers on FIBRO Progression/Lamination Die Set Units are laid out for the functions of punch guiding and clamping of the stock, derived from preloaded spring/spacer units of highly compact design.

The advantages of these compact units, in accordance with executions 1 to 4, are as follows:

- a) compactness – the combination of both spring- and spacer functions saves die space
- b) ease of die maintenance – punch regrinding and replacement, as well as dimensional adaptation, can be done without dismantling of the stripper.
Note: regrinding of punches = regrinding of spacer!
- c) ease of springs maintenance – after removal of only the top clamping plate, the complete spring/spacer unit can be taken out for replacement etc. This feature applies to executions 1 and 2 only.

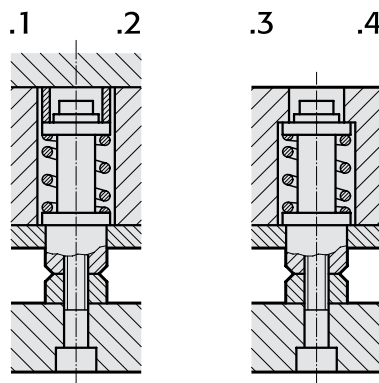

Retaining Slots for Matrixes and Guiding-Stripper Plate

It is of paramount importance to the accuracy of the final die assembly that both these slots are in perfect vertical alignment, to within a few mm.

From long experience we know that all heavy machining of die set apertures must precede the finish-machining of the two retainer slots for the matrix inserts and the guiding/clamping stripper plate.

Whenever the machining of such apertures is not entrusted to us we will supply our Die Set Units with pre-ground slots only.

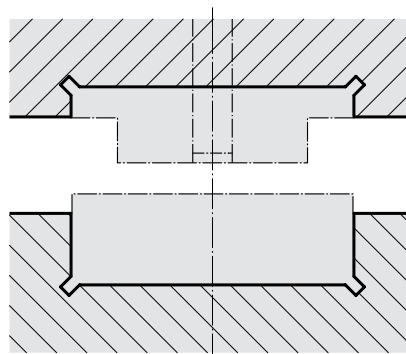

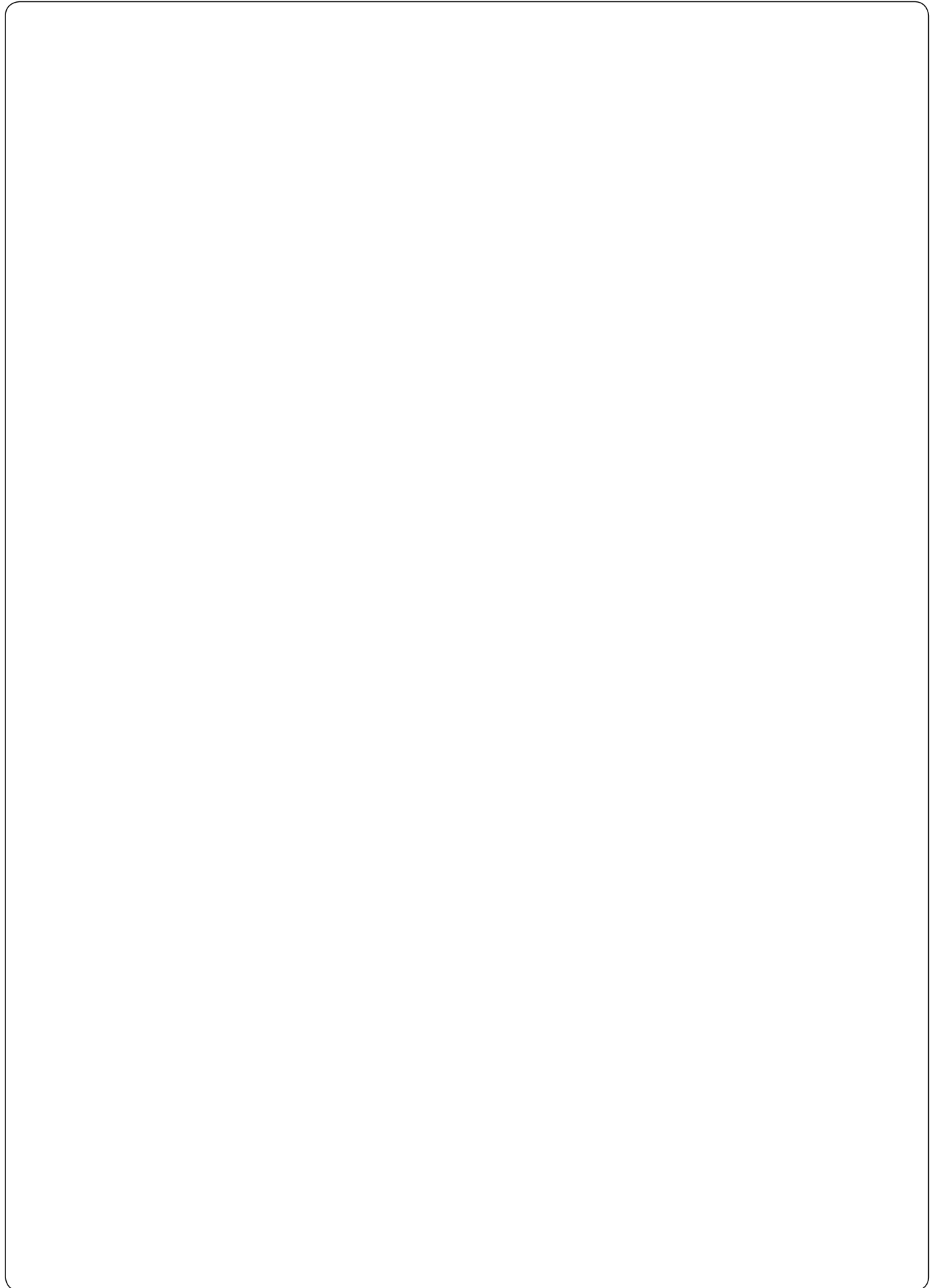



Tooling Pallet Die Sets

Description

The fast exchange of pallet-born tooling sets, with the concept of rapid mechanical positioning, meets the demands for:

- lowering of tooling cost
- reduction in setting costs
- faster response to market trends.

Instead of a multitude of complete die set-born press tools, the new system is based on a carrier die set with rapid-exchange features. This die set can remain in the press, while any number of tooling pallet sets can be accommodated expediently and precisely, one at a time. There are no individual guide elements associated with a tooling pallet set – the necessary guiding remains a function of the carrier die set exclusively.

Tooling pallet sets are mounted to standard carrier plates – the top and bottom tooling simply slides into position, where a stop provides the positioning control, to allow entry of the locating pins upon the required half-turn of each of the four pin actuation levers on the die set. With the tooling pallets now positioned accurately, the hexagonal clamping screws at the front of the die set can be turned with a box spanner, each activating one clamp via an internal cam, moved by threading action of the screw. The cam angle is such that self-locking is obtained.

Press Tool Types

Sets of pallet tooling can be designed as:

- combination progression tools
- compound tools
- draw dies
- bending- and forming dies
- combination tools etc.

Setting and Tryout Aids

The absence of individual guide elements is a fundamental feature of tooling pallet sets which greatly assists the overall economy of the system. In order to facilitate the aligning of top- and bottom tooling, conical centring units can be fitted, thus providing alignment between both members by direct means – even outside the carrier die set, on the toolmaker's bench.

As a further aid for setting and tryout of pallet sets we offer the FIBRO Aligning- and Tryout Press Unit 201.98. with simplified but basically similar positioning- and locking features as the carrier die set.

Setting

- slide each pallet into its position
- positioning
- clamping

These steps can be completed in a minute.

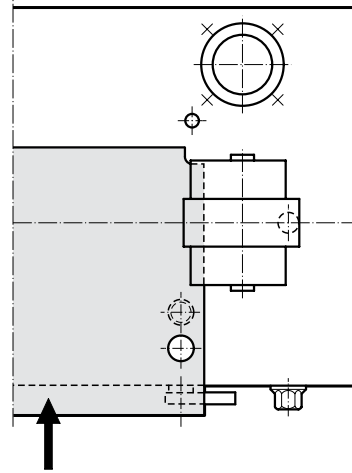
Slide-In Insertion**Sheet Thicknesses**

Sheet less than 0,4 mm in thickness is normally not recommended for the system – on account of the smaller punch-to-die clearances associated with thin stock materials, where the normal positioning accuracy within the carrier die set (approximately 0,02 mm) becomes insufficient.

However, through fitting of conical centring units the overall alignment accuracy can be improved to an extent where even sheet below 0,4 mm thickness can be processed successfully.

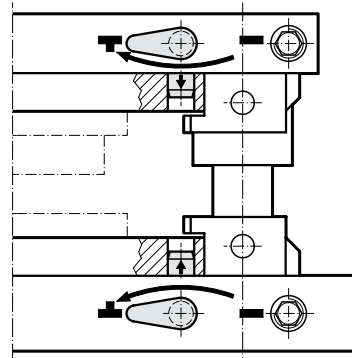
Positioning**Positioning Aids**

Pallet tooling sets can be equipped with conical centring units.

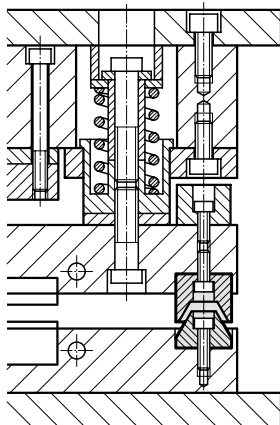
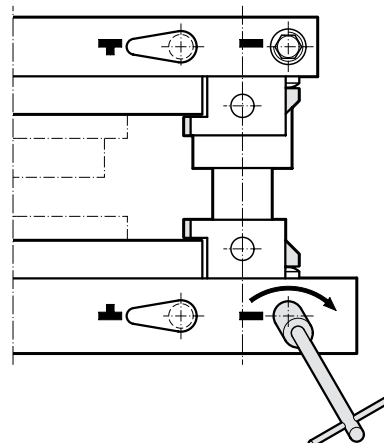
**Clamping**

Overview of Pallet Tooling System

201.95.

Top Bolster of Pallet Die Set

- 1 top bolster
- 2 pallet carrier plate – for slide-in insertion
- 3 guide bushes – optionally sliding – or ball bearing guides
- 4 clamp
- 5 positioning pin – descends below surface
- 6 positioning pin lever
- 7 stop pin
- 8 clamping screw

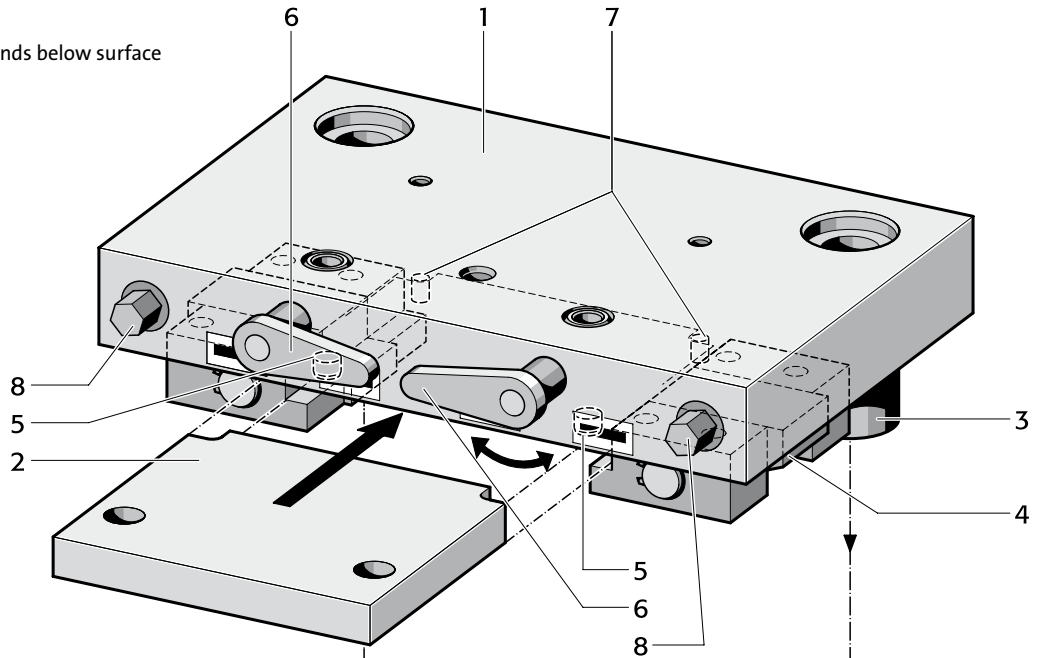

Bottom Bolster of Pallet Die Set

- 1 bottom bolster
- 2 pallet carrier plate – for slide-in insertion
- 3 guide pillar
- 4 clamp
- 5 positioning pin – descends below surface
- 6 positioning pin lever
- 7 stop pin
- 8 clamping screw
- 9 bolster insert plate
- 10 box spanner

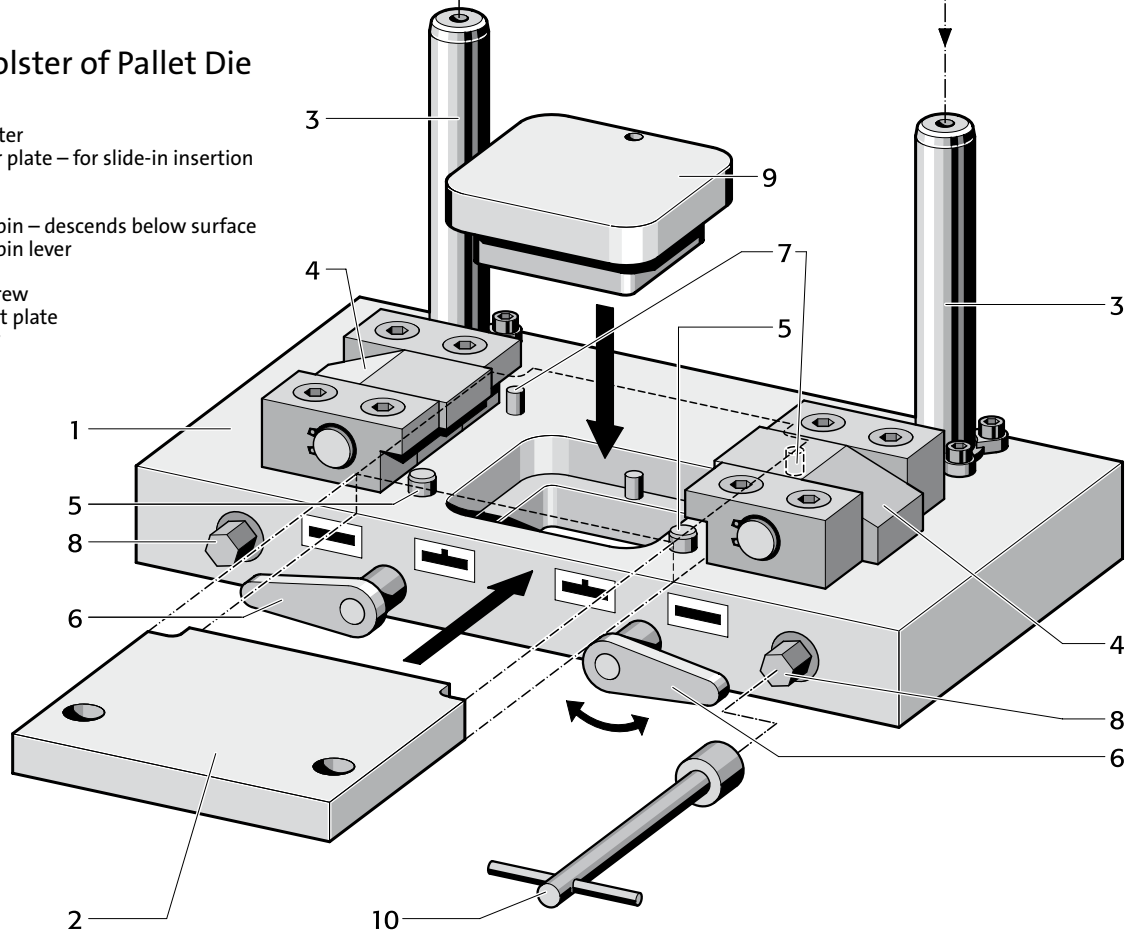

201.95.

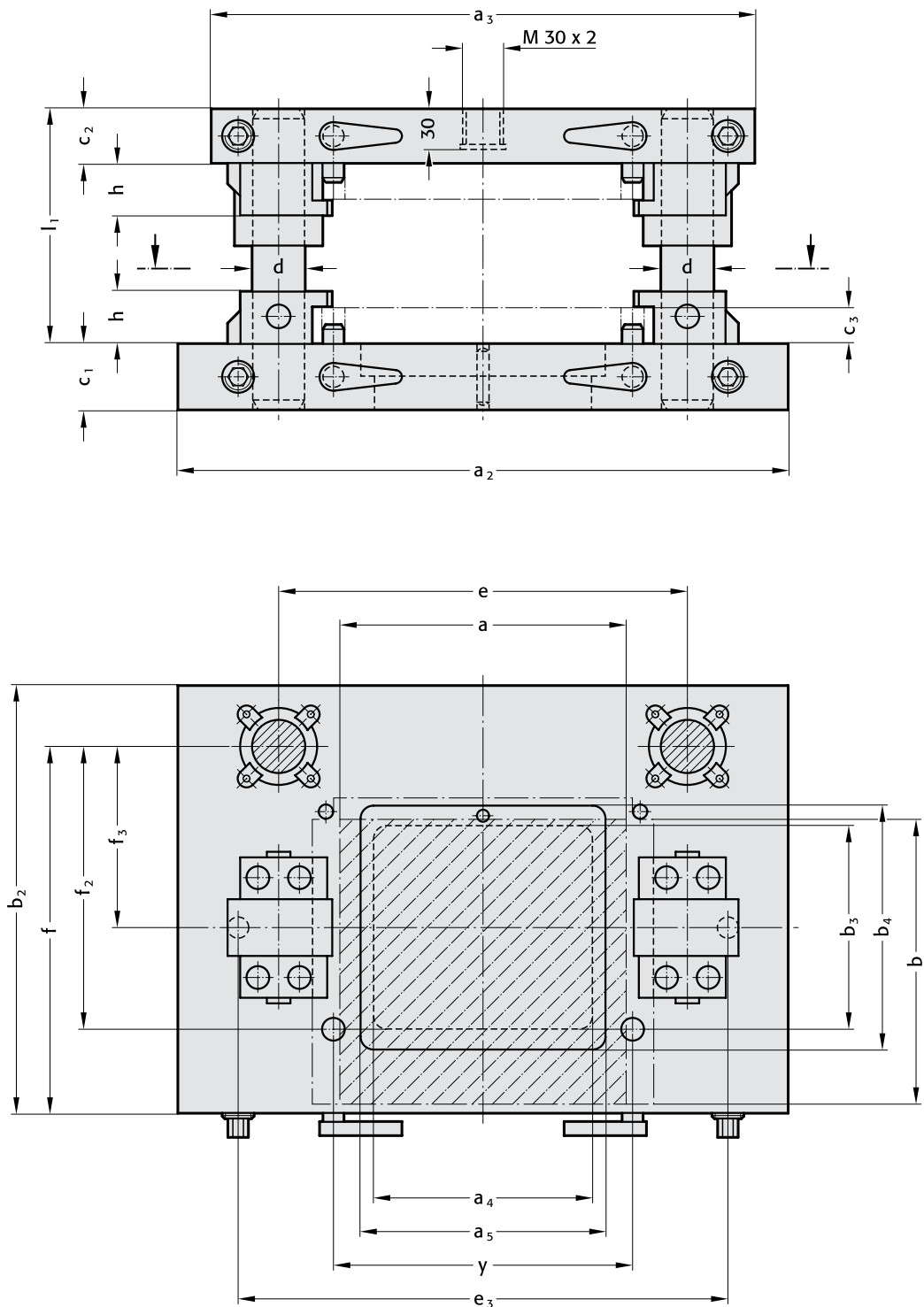

201.95.

Order No	work area		a_2	a_3	a_4	a_5	b_2	b_3	b_4	c_1	c_2	c_3	d	e	y	e_3	f	f_2	f_3	h	l_1
	$a \times b$																				
201.95.1010.	100 × 100		350	300	80,5	-	200	60	80,5	40	40	16	25	220	120	260	168	113	93	29	160
201.95.2121.	210 × 210		450	400	161	180,2	315	150	180,2	50	40	25	40	300	220	360	270	208	133	38	180
201.95.3030.	300 × 300		550	500	241	270,5	420	220	250,5	63	40	25	40	380	320	460	365	305	185	38	180
201.95.3521.	350 × 210		600	550	320	-	315	120	150	50	40	25	40	450	370	510	270	208	133	38	180

Complete Order No with type of guides – i.e. .831 for sliding-, .862 for ball guides

Pallet Carrier Plates Bolster Insert Plates

Pallet Carrier Plates

For each pallet tooling set, two carrier plates 201.96. are required – one for mounting the top tooling details, the other for the bottom tooling.

The tooling components are dowed into position.

201.96.

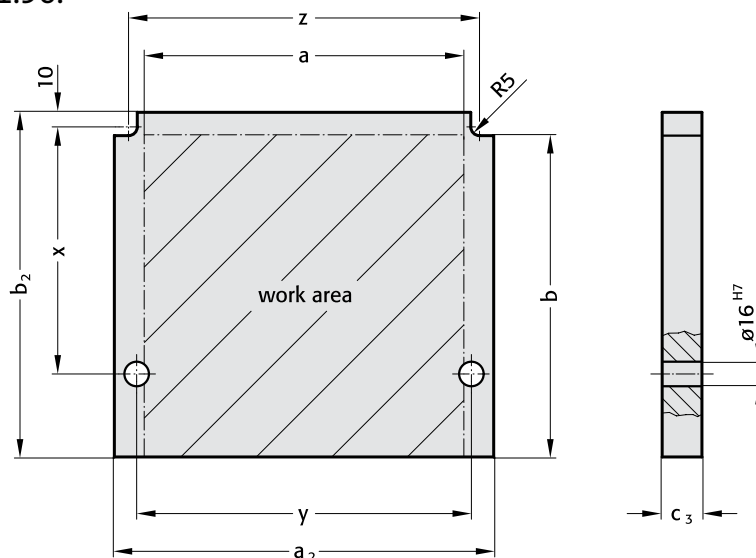

201.96.

Order No.	work area a x b	a ₂	b ₂	c ₃	x	y	z
201.96.1010	100 u 100	150	115	16	50,1	120	130
201.96.2121	210 u 210	250	225	25	160,1	220	230
201.96.3030	300 u 300	350	315	25	250,1	320	330
201.96.3521	350 u 210	400	225	25	160,1	370	380

Bolster Insert Plates

This insert plate has to be added to a tooling pallet set if:

- scrap holes near the centre require additional support
- spring cushions or bottom ejectors have to be employed
- other features of specific die designs require an individual insert plate

Bolster insert plates have a dowel that makes them non-reversible.

201.97.

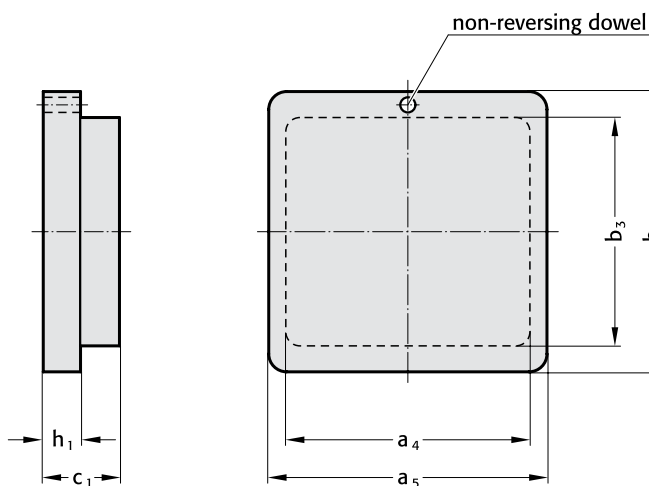

201.97.

Order No	work area a x b	a ₄	a ₅	b ₃	b ₄	c ₁	h ₁
201.97.1010	100 x 100	80	-	60	80	40	20
201.97.2121	210 x 210	160	180	150	180	50	25
201.97.3030	300 x 300	240	270	220	250	63	30
201.97.3521	350 x 210	320	-	120	150	50	25

FIBRO

201.98.

Aligning- and Tryout Press Units

201.98.

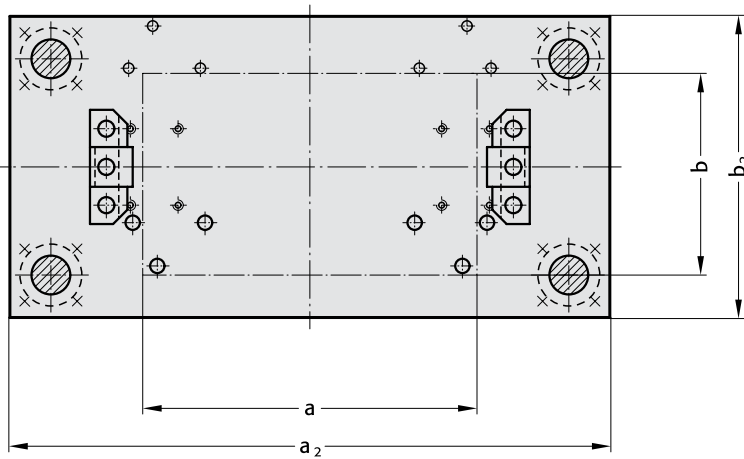
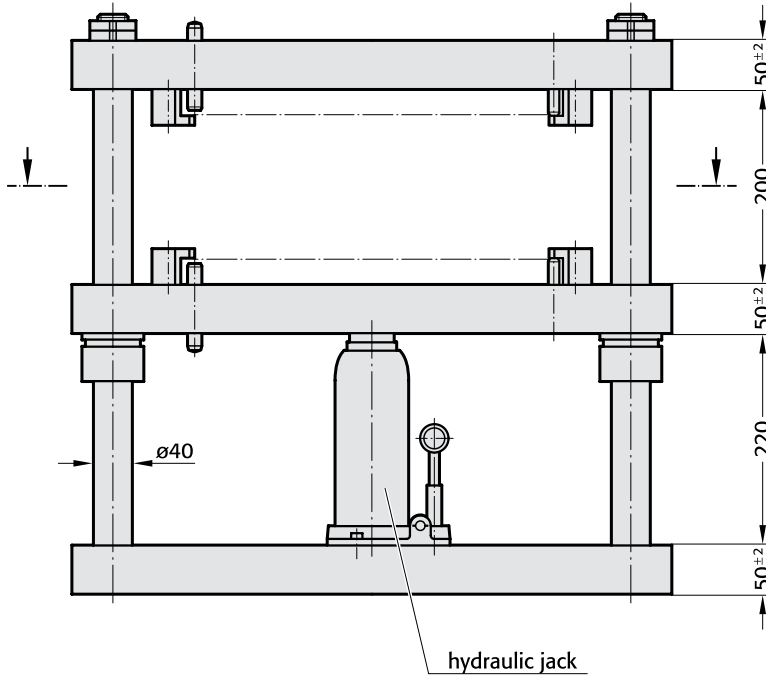

Description

These press units have manual actuation by way of a hydraulic jack which forces the guided bolster upwards. In the toolroom they serve as tryout- and setting press, especially for tooling pallet sets. For the latter purpose they are equipped with simplified but functionally similar features for positioning and clamping as those in FIBRO Tooling Pallet Die Sets.

Moreover the press units provide ideal facilities for the press-fitting of pillars and bushes etc. – or their removal. For blueing-in and tryout of all sorts of press tools they soon prove themselves as an indispensable workshop facility, with a maximum thrust of 10 tons.

201.98.

Order No	work area a × b	a ₂	b ₂
201.98.1010.863	100 × 100	315	250
3030.863	210 × 210	630	315
	300 × 300		
	350 × 210		

Material:

Plate: St 52-2

Execution:

Headed ball bearing guide bushes, hydraulic jack, 10 tons capacity

